



(11) **EP 2 172 956 B1**

(12) **EUROPEAN PATENT SPECIFICATION**

(45) Date of publication and mention of the grant of the patent:
13.02.2013 Bulletin 2013/07

(51) Int Cl.:
H01H 3/30 ^(2006.01) **H01H 33/666** ^(2006.01)
H01H 31/10 ^(2006.01) **H01H 33/52** ^(2006.01)

(21) Application number: **09354038.3**

(22) Date of filing: **01.10.2009**

(54) **A mechanism for the synchronized operation of closing and opening of a switching device and a selector device in a switchgear**

Mechanismus für den synchronisierten Betrieb des Schließens und Öffnens einer Schaltvorrichtung und Auswahlvorrichtung in einer Schalteinrichtung

Mécanisme pour le fonctionnement synchronisé de la fermeture et de l'ouverture d'un dispositif de commutation et d'un dispositif de sélection dans un appareil de commutation

(84) Designated Contracting States:
AT BE BG CH CY CZ DE DK EE ES FI FR GB GR HR HU IE IS IT LI LT LU LV MC MK MT NL NO PL PT RO SE SI SK SM TR

(30) Priority: **03.10.2008 IN CH24362008**

(43) Date of publication of application:
07.04.2010 Bulletin 2010/14

(73) Proprietor: **Schneider Electric Industries SAS**
92500 Rueil-Malmaison (FR)

(72) Inventors:
• **Kumar M.C, Harsha**
38050 Grenoble Cedex 09 (FR)
• **Sonkar, Pavankumar S**
38050 Grenoble Cedex 09 (FR)
• **Bahirat, Himanshu**
38050 Grenoble Cedex 09 (FR)

- **Sinjonja, Manish**
38050 Grenoble Cedex 09 (FR)
- **Kumar, Randhir**
38050 Grenoble Cedex 09 (FR)
- **Perrone, Michel**
38050 Grenoble Cedex 09 (FR)

(74) Representative: **Colette, Marie-Françoise**
Schneider Electric Industries SAS
Service Propriété Industrielle
WTC - 38EE1
5, place Robert Schuman
38050 Grenoble Cedex 09 (FR)

(56) References cited:
EP-A1- 1 884 972 EP-A2- 1 529 299
DE-A1- 2 533 343 DE-A1- 3 312 661
DE-B- 1 276 174 DE-B3-102006 041 374

EP 2 172 956 B1

Note: Within nine months of the publication of the mention of the grant of the European patent in the European Patent Bulletin, any person may give notice to the European Patent Office of opposition to that patent, in accordance with the Implementing Regulations. Notice of opposition shall not be deemed to have been filed until the opposition fee has been paid. (Art. 99(1) European Patent Convention).

Description

Field of Invention

[0001] The present invention relates to a mechanism for synchronized operation of closing and opening of a vacuum bottle switching device and a selector device in a switchgear.

Background of the Invention

[0002] The contacts of the circuit breaker and selector switches need to be actuated in a predetermined manner for the operation of a compact switchgear.

[0003] US 3, 571, 543 discloses an operating mechanism to actuate the contacts of a vacuum switch and the contacts of a selector switch in a predetermined sequence. The vacuum switch contacts are connected in series with the contacts of the selector switch and a cam is provided as the programming means. The cam converts a portion of the operator output into linear motion so that the vacuum switch contacts are caused to close after the selector switch contacts close and are opened before the selector switch contacts open.

[0004] EP 1 529 299 B1 describes a switchgear according to the preamble of claim 1.

[0005] There is a need developing a well synchronized and well balanced mechanism four position of combination of vacuum circuit breaker and selector whose operation is safe and reliable between the two mechanisms. Due to interlocking as will be defined in the present disclosure one mechanism becomes inoperable when the other is operating.

Brief Description of the Invention

[0006] The present invention discloses a 4-position mechanism for the synchronized operation of closing and opening of a vacuum bottle switching device and a selector device. The synchronized operation is achieved with the help of interlocks. Each of the vacuum bottle switching device and the selector device comprise separate energy storage and releasing means. Energy is loaded into both the devices by the user input with the help of dedicated levers. The movement in the output shafts is observed only after the dead point has been reached. Any movement from dead point to the main output shaft is transmitted through articulated levers. In the vacuum bottle switching device, conversion of energy makes the main shaft translate in one direction to close the switch and also, stores energy for translation of the shaft in opposite direction to open the switch.

[0007] In the selector device, conversion of energy makes the rotating arm disengage from one port and engage the other port. All the operations operate with high speed and force (in case of vacuum bottle switching device) and torque (in case of Selector device) transmitted to the main shaft increases in the course of operating

movement.

[0008] Accordingly, the invention discloses a mechanism for the synchronized operation of closing and opening of a vacuum bottle switching device and a selector device in a switchgear wherein said mechanism includes a switching device operating means, a selector operating means and an earth operating means, each of said means having a handle receptor to accommodate a removable handle; said mechanism further comprising: a first interlock arrangement for controlling access to either the switching device operating means or the selector operating means; a second interlock arrangement for controlling access to either the selector operating means or the earth operating means; a first link provided such that one end of said first link is in contact with a crank of the switching device and the other end is in contact with the said first interlock arrangement; a second link provided such that one end of said second link is in contact with a crank of the switching device and the other end is in contact with the said second interlock arrangement; said first and second interlock arrangements being configured such that upon insertion of said handle into an accessible handle receptor of any one of said selector operating means, switching device operating means or earth operating means, the access to the remaining operating means is blocked.

[0009] Further, a push button is provided to move the switching device from a closed position to an open position, the access to the selector operating means and the earth operating means being blocked.

[0010] Further, when the switching device is in the open position, the handle is capable of being inserted either in the switch operating means to move the switching device to the closed position, or, in the selector operating means to move the switching device to a disconnect position.

[0011] Further, when the switching device is in the disconnect position the handle is capable of being inserted either in the selector operating means to move the switching device to the open position, or, in the earth operating means to move the switching device to an earth position.

[0012] Further, when the switching device is in the earth position the handle is capable of being inserted only in the earth operating means to move the switching device to the disconnect position.

Brief Description of the Drawings

[0013] Referring now to the drawings wherein the showings are for the purpose of illustrating a preferred embodiment of the invention only, and not for the purpose of limiting the same,

Figures 1 - 4 shows the isometric view of the assembly of the switching device and the selector device along with the mechanism for synchronized operation of closing and opening of a switching device and a selector device in accordance with this invention.

Figure 5a shows the functional synopsis of the 4-position mechanism in accordance with the invention.

Figure 5b shows the truth table for each of the 4 positions indicating the position of the shutters of the mechanism.

Figure 6a - 6c is the schematics and the mechanism of the selector device providing two positions to the switchgear by selecting either earth or line position.

Figure 7a & 7b show the isometric views of the selector mechanism.

Figure 8 shows the selector in the line position

Figure 9 shows the schematic of the vacuum bottle switching device

Figure 10 & 11 show the compact circuit breaker mechanism.

Figure 12a shows the position of links when the circuit breaker is in the open condition.

Figure 12b shows the position of the links when the circuit breaker is in the closed condition.

Figures 13a - 13d show the front and isometric views of the handle receptors of the selector, the switch and the earthing operating apparatuses.

Figure 14 shows the interlocks of the 4-position mechanism in position 1

Figure 15 shows the interlocks of the 4-position mechanism in position 2

Figure 16 shows the interlocks of the 4-position mechanism in position 3

Figure 17 shows the interlocks of the 4-position mechanism in position 4.

Detailed Description of the Invention

[0014] In the isometric views shown in Figures 1 to 4, the frame/envelop 1 and handle rod 18 is common to both the switching and selector devices. Almost all the mechanism links are mounted on this frame. The frame consists of four metal plates, which are placed parallel to each other. The inner two plates support selector device components, while switching device components are supported on the outer two plates. However, few components of switching device are supported by the inner two plates too.

[0015] The constituent components of the switching

device such as camshaft (2), cam (3), crank 4, lever 5, slider 6, the opening spring 7, the contact pressure spring 8, half moon bar mechanism 15, latch 16, closing spring 17 and the handle rod 18 are indicated in the Figures 1 to 4. It is also to be noted that a co-pending application has also been filed that discloses the operating mechanism of the compact switching device having the above said main components.

[0016] The constituent components of the selector device such as the spring arm driver 19, the output arm actuator 20, the intermittent arm 21, the slider arm 22, the output arm 23 and the handle spring arm driver 24 are also shown in the Figures 1 to 4.

[0017] The interlock components such as the circuit breaker - selector - earth interlock 25, the circuit breaker - selector - line interlock 26, the circuit breaker - earth interlock 27 and the circuit breaker - line interlock 28 is also illustrated in Figures 1 to 4.

[0018] Also, the pumping system components such as the gears, pinions and ratchets 9, 10, 11, the locking pawl 12, the driving pawl 13, the handle receptor 14 are shown in Figures 1 to 4.

[0019] In this assembly of four positions mechanism, the fascia contains three openings/ports. In order to make the device follow sequences mentioned in Figure 5a, different openings are made accessible or inaccessible based on the truth table of Figure 5b. Also, to satisfy an essential function, another pumping system is provided to take the device to earth position from disconnect position (refer Figure 5a). However, the principle of working of both the pumping systems of switching device remains same.

[0020] The mechanism of the synchronized four positions achieved by the device is described below with reference to Figures 5a and 5b.

[0021] Operations that lead to move from one position to the next or the previous one are allowed (for example, from position 1 to position 2 or position 2 to position 1, from position 2 to position 3 or position 3 to position 2, etc...). Any other operations are forbidden. Also, it is forbidden to use the same pumping system while moving from 2 to 1 and from 3 to 4. Hence, the switching device has two pumping systems; one system is used to move from open position to close position and other system is used to move from disconnect position to earth position. In simpler words, there are different positions of actuation for closing and earthing of switching device. However, the rotational lever remains essentially same for all the operations. The truth table (Figure 5b) indicates availability of different ports of the devices, which can be operated at a particular position.

Assembly of the Four Positions Mechanism

[0022] **Principle:** The four positions mechanism consists of two sub-devices, namely, the selector device and the switching device. Having developed the switching device and the Selector device first, these devices were

incorporated along with interlocks and pumping systems inside a dedicated volume, which is very compact for this range of devices.

[0023] In the final installation, vacuum bottle remains horizontal. The switching device is kept in the bottom half of the volume while Selector device occupies top half of the volume. Interlock comes just behind the fascia and before the two devices. Also, there are three different openings for actuating four positions mechanism. Out of these three ports, one is used to actuate Selector device (Port: 1) while other two are used to actuate switching device in normal operation of close/open (Port: 2) and to earth (Port: 3). It should be noted that, for switching device opening, there might be a requirement for push button kind of component and consequently an opening for it on the fascia. However, the push button port on fascia does not require any covering or uncovering for the sequences and positions of mechanism disclosed herein.

The Selector Device

[0024] Principle: The main function of this device is to provide two positions to the switchgear by selecting either earth or line position. Figure 6a shows the schematic of the earth and line positions of the selector device.

Description of Selector Mechanism

[0025] The objective of the selector mechanism is to provide two positions to the disconnecter either line position or the earth position. The selector mechanism in its 2 stable states is shown in Figures 6b and 6c (the static components are not shown). The selector mechanism is principally a slider crank mechanism having a slider arm 30 and a crank 31, which utilizes a spring 32 to store energy. During the initial part of the charging stroke (rotation of the handle in the handle receptor 33 no motion of the slider 30 is observed. Once the spring 32 has crossed its toggle point the spring discharges and the crank 31, connecting rod 34 and in turn the slider 30 is set into motion thereby dislodging the moving contacts from one set of contacts and inserting them into another set of contacts (the moving contacts and the other contacts are not shown in the figure). It should be noted that the handle receptor 33 has two separate positions as shown in the 2 positions of the selector mechanism (line condition and earth condition). The links are so designed that the torque that the moving contact is experiencing decreases initially and then continually increases. Figures 7a and 7b shows the isometric views of the selector mechanism along with other static components of the selector device which was not shown in figures 6b and 6c.

[0026] Figure 8 shows the selector mechanism in the line position. This figure is very similar to figure 6b. In order to understand the working of the selector mechanism, it is assumed that the mechanism to move to the earth condition is being used. In order for this to happen, the removable handle is inserted into the handle receptor

33 shown in line position of figure 6b, and rotated in the direction shown by the circular arrow in figure 8. When this is happening, the spring arm driver 35 and the spring 32 that is mounted on it are moving causing the spring 32 to get charged. But the spring arm connector is not moving as the spring arm driver 35 is moving in a slot on the spring arm connector, so no motion is transferred to the slider arm 30. Once the spring 32 crosses the toggle point, the spring arm driver 35 and the spring 32 reach the end of the slot 36a on the output arm connector 36 and now cause the output arm connector 36, the output arm 31 and the slider arm 30 to start moving.

[0027] A similar process takes place in moving from the earth position to the line position.

Vacuum Bottle Switching Device

[0028] Principle: The main function of this device is to make and break the connection with vacuum bottle fixed contacts with good speed and to generate required contact pressure at the end of stroke.

[0029] The switching device contains a pumping system, an energy storage means for closing and opening (compression springs), a cam with oscillating follower in which follower is crank of a slider crank mechanism, a latch unit and a contact pressure creation system. As mentioned earlier, a co-pending application has been filed for the mechanism of the switching device, which is incorporated herein as reference in its entirety.

[0030] The switching device is charged with the help of a dedicated pumping mechanism in five strokes. Just before the completion of fifth stroke, closing springs toggle and cam pushes a set of articulated levers (slider crank mechanism) to close the contacts. After closing springs toggle, the movement of contacts becomes independent of the pumping system. Contact pressure is established in the last one-third movement of main shaft and trip unit comes to its place, once the required contact pressure has been generated. The main shaft experiences a monotonically increasing force, as it moves towards fixed contacts.

[0031] Figures 10 and 11 show the circuit breaker mechanism in its open position. The pumping system of switching device contains gear 9, pinion 10, ratchet wheel 11, locking pawl 12, driving pawl 13, handle receptor 14 and a common rotational handle. The handle is rotated manually five times through an angle. In every stroke, driving pawl engages with the pinion and rotates the cam shaft 2 by rotating the gear. After completion of about 75% of 5th stroke, closing springs 17 toggles and the cam 3 starts pressing the crank 4, which in turn drives the moving contact with the help of a set of articulated levers (5 & 6). After traversing a certain predetermined distance in the horizontal direction (It is to be noted that the vacuum bottle is horizontal), contact pressure springs 8 are compressed by a certain distance, creating a minimum contact force. As the slider 6 travels it compresses and hence charges the opening springs 7, energy of

which is utilized while contact are breaking.

[0032] There is a latch 16 with half moon bar 15, which stops the slider from coming back (moving away from fixed contact), once the contact has been made. There is an extension spring associated with latch 16, trying to pull the latch 16 downward, making sure that the latch 16 remains always in contact with the slider 6. Half moon bar 15 also has a torsion spring at its axis, which tries to rotate it towards latch 16. Once the contacts are made, latch 16 restricts the possibility of slider 6 coming back. In this phenomenon, latch 16 tries to rotate back and regain its original configuration, but the half moon bar 15 prevents such rotation.

[0033] When contacts need to be opened, the half moon bar 15 is rotated with the help of a push button. As soon as half moon bar 15 slides off from the latch 16, slider along with the moving contact comes back to the open position, rotating latch 16 in clockwise direction to regain its original configuration.

Description of the operation of the interlocks and their function in achieving the 4 positions.

Operation of the interlocks.

[0034] The interlocks are primarily a set of shutters (shutter operation will be explained later in the specification), which allow or prevent access to ports where a removable handle may be inserted to operate the 4 Positions mechanism. Depending on which of the 4 positions the mechanism is currently in, the shutters are positioned. The position of the shutters follows the shown truth table shown in Figure 5b.

[0035] The four positions of the 4-P mechanisms are shown in Figure 5a.

[0036] *In position 1* both the switch and the selector are in the closed position and also in order for the transition to position 2 to happen the switch should open only through the use of the switch handle. So it is imperative that only access to the switch operating apparatus be accessible and all other operating apparatus be blocked. Similarly when moving from position 2 to 1 only the switch operating apparatus is to be accessible and access to all other operating apparatus is to be blocked. This is shown very clearly in the truth table of Figure 5b.

[0037] *In position 2* the switch is in the open position. Therefore, there are 2 possibilities, i.e., the switch can be operated and moved back to the closed position (position 1) or the selector can be operated and moved to the disconnected position (position 3). Thus, when in position 2, it is necessary to allow access to both the selector operating apparatus and to the switch operating apparatus but prevent access to the earth operating apparatus of the switch (It is to be noted that the switch performs the operations of both closing and earthing through the use of different operating apparatus). Also, at any instant of time only one operation is permitted. Thus when in position 2 if one decides to operate the switch and move

back to position 1, the instant the removable handle rod is inserted into the switch operating apparatus, access to the selector operating apparatus is to be blocked (and as before the earth operating apparatus is blocked). Similarly in position 2 if it is decided instead to operate the switch and move to position 3 (disconnect), the instant the removable handle is inserted into the selector operating apparatus, the access to the switch operating apparatus is to be blocked (as before the earth operating apparatus is still blocked).

[0038] *Position - 3* is similar to position 2, in the sense that there are 2 possibilities of operation, i.e., the switching device could be moved to position 2 by choosing to operate the selector operating apparatus or move to position 4 by choosing to operate the earth operating apparatus, also choosing one operation precludes the other operation as in the case of position 2, except that in this case there will be no access to the switch operating apparatus, and instead, access exists only to either the selector operating apparatus or the earth operating apparatus.

[0039] *Position - 4* is similar to position - 1 in the sense that only the earth operating apparatus can be operated as access to all other operating apparatuses is blocked through the use of the shutter mechanisms.

[0040] The shutter mechanisms that are used to achieve the above 4 positions of the mechanism is described in greater detail below.

[0041] Before describing the shutter mechanism it is necessary to understand the operations of the switch and the selector mechanisms and the roles they play in the proper functioning of the shutter mechanisms to achieve the 4 positions.

[0042] The selector mechanism is a bi-stable toggle mechanism i.e. there are 2 stable positions for the mechanism, namely, a stable line position and a stable earth position. The selector operating apparatus also has two positions. For example, when moving from line to earth position, the handle and all associated parts are turned through a certain angle and remain there till the complimentary operation i.e. moving from earth to line operation is executed. So in effect a single stroke of sufficient force through the required angle is enough to cause the selector to move between the two stable positions.

[0043] However, in the case of the switch, five charging strokes of the removable handle is required to move from the open to close condition of the switch. Similarly five charging strokes of the removable handle is required to move from the disconnected to the earth position. However, to move from the earthed to the disconnected position only a single stroke of the removable handle is needed in a direction opposite to that of the charging stroke of the earthing operation. In the case of the switch, to open the switch, i.e. to move from the closed to the open position a push button is required.

[0044] Summarizing the operations of the 4 positions:

1. In moving from position 1 to position 2 the push

button of the switch operating apparatus is required to be operated; also access to all other operating apparatuses are blocked. Thus in position 1 access is provided to only the switch operating apparatuses and access to all other operating apparatuses is blocked.

2. In position 2 there are 2 operations possible, i.e. it could be moved to position 1 by inserting the removable handle into the switch operating apparatus and giving five charging strokes or it could be moved to position 3 by inserting the removable handle into the selector operating apparatus and give a single stroke and move to position 3. Also if removable handle is inserted into the switch operating apparatus then access to the selector and all other operating apparatuses is blocked. Similarly if the removable handle is inserted into the selector operating apparatus then access to the switch and all other operating apparatus is blocked, that is to say, the two possibilities are mutually exclusive.

3. In position 3 there are 2 possible operations, i.e. it could be moved to position 2 by inserting the removable handle into the selector operating apparatus and operating it, or it could be moved to position 4 by inserting the removable handle into the earth operating apparatus and giving five charging strokes. Again it is to be noted that the two possibilities are mutually exclusive and all other possibilities are blocked.

4. In position 4 only the earth operating apparatus is accessible and only one operation is possible. The removable handle could be inserted into the earth operating apparatus and given a stroke in a direction opposite to that used for charging and this would take it to position 3. Position 4 is quite similar to the position 1 except that in this case there is access to the earth operating apparatus and not the switch operating apparatus as in position 1.

Explanation of the operation of interlock mechanism

[0045] It has already been mentioned that the 4 Positions are achieved through the use of a shutter arrangement of the links. The shutter is a spring-loaded rigid part that is pivoted on an axis so as to always remain in contact with a certain moving part of the mechanism. This ensures that whenever the moving part of the mechanism moves, the shutter also moves and being spring loaded always has an unambiguous and definite position (i.e. it has a stable state always). It is to be noted that since removable handle is used the shutters are designed to partially cover the access to any operating apparatus at any instant.

[0046] There are two shutters and two links which are spring loaded. One shutter arrangement is so mounted

to control access to either the switch operating apparatus or the selector operating apparatus and another shutter arrangement is so mounted to control access to either the selector operating apparatus or the earth operating apparatus. The partially covered apertures of the operating mechanisms are so designed that if the handle is inserted into the switch operating apparatus, the shutter, which was partially covering access to both the switch and selector operating apparatus, now turns to allow the handle to be inserted into the switch operating apparatus and completely blocks access to the selector operating apparatus. Similarly if the handle is inserted into the selector operating apparatus, the shutter turns to allow the handle to be inserted and completely blocks access to the switch operating apparatus.

[0047] Also, the selector operating apparatus has two stable states whereas the switch and earth operating apparatus has only one stable state. Therefore, the shutters would have to control access to the selector operating apparatus in two places whereas the shutters would have to control access to the switch and earth operating apparatus in only one place each. In order to control access to the operating apparatus of the mechanisms the position of the mechanism at any instant of time is required to be made note of. This is done by using the aforementioned two links, which are pivoted on the frame and spring loaded so that one end of the link is always in contact with the crank of the circuit breaker mechanism and the other ends of the links are in contact with the two shutters. The crank is chosen to control the two links because the position of the crank clearly reflects the condition of the circuit breaker as explained in the following paragraphs.

[0048] In figure 12a, the position of the links 37a, 37b in relation to the crank 4 and the lever 5 of the circuit breaker, when the circuit breaker is in the open condition is shown. In figure 12b the position of the links 37a, 37b in relation to the crank 4 and the lever 5 of the circuit breaker, when the circuit breaker is in the closed condition is shown. This change in position of the links 37a, 37b is used to control the position of the shutters and in turn control the access to the operating mechanisms.

[0049] In figures 13a to 13c the front and isometric views of the selector handle receptor 33, the switch handle receptor 14 and the earthing handle receptor 38 are shown (All other parts have been hidden for ease of understanding). The position of the handle receptors 14, 38 of the switch and the earth operating apparatuses always remains the same as they are spring loaded to return to the same position (as indicated in the figure 13c) after the operation is complete. So the shutters are designed such that they need to control access to the switch and earth handle receptors in this position only. But in the case of the selector operating apparatus the position of the handle receptor 33 is different in the line and the earth positions (of the selector).

[0050] In the figure 13a to 13c the selector handle receptor 33 is in the line position and in figure 13d the se-

lector handle receptor 33 is in the earth position.

[0051] The shutter that controls access to the selector is designed to take care of both positions of the selector handle receptor 33.

Explanation of the shutter operation.

Interlocks in position-1

[0052] In this position the circuit breaker is closed and so is the selector (line position). As per the truth table it is required that only the switch operating mechanism (switch handle receptor and the opening push button) is to be accessible. Figure 14 indicates the position of the shutters 39, 40, links 37a, 37b and handle receptors 14, 33, 38.

[0053] In figure 14 only the switch handle receptor 14 (and the opening pushbutton) is accessible. This is explained as follows.

[0054] It is not possible to insert the handle in the selector handle receptor 33 because, for this to happen, the first shutter 39 (Pivoted on axis A) would have to rotate in a clockwise direction to allow for handle insertion. But this is not possible as the first link 37a) prevents the rotation of the first shutter 39 in the clockwise direction. Similarly it is not possible to insert the handle in the earth handle receptor 38 as for this to happen the second shutter 40 (pivoted on axis B behind first shutter 39) would have to rotate in the anticlockwise direction which is not possible as the second link 37b blocks the rotation of the second shutter 40 in the anticlockwise direction. So the only accessible apparatus is that of the switch, which can be moved to position 2.

[0055] The position of the interlocks in position 2 can be seen in figure 15. The positions of the first shutter 39 and the second shutter 40 are the same as in the case of position 1 but the positions of the links 37a, 37b are different, since, the position of the cranks 4 has now changed (they appear as shown in figure 12a). As the circuit breaker is now in the closed condition the links 37a, 37b no longer block the operation of either the switch or the selector. Inserting the handle into either the switch handle receptor 14 or the selector handle receptor 33 will cause the other's access to be blocked. Also, access to the earth handle receptor 38 is still blocked by the second shutter 40, since, for the second shutter 40 to move the selector handle receptor 33 should move towards the position it occupies when in the earth position (i.e. when the selector is in open condition). Thus, only the switch and the selector handle receptors 14, 33 are accessible at a time in position 2.

[0056] The positions of the shutters 39, 40 and links 37a, 37b in position 3 are as shown in figure 16. The links 37a, 37b no longer block the first and second shutters 39, 40 but the position of the selector handle receptor 33 has changed and is now as it would be in the earth condition (as in figure 13d).

[0057] The selector handle receptor 33 and the earth

handle receptor 38 are accessible one at a time (the second shutter 40 ensures that upon inserting the handle into any one accessible port the other is completely blocked). The switch handle receptor 14 is completely blocked by the first shutter 39 and the first shutter 39 rests on second shutter 40 such that if first shutter 39 is to move then second shutter 40 is also required to move. This means that the position-3 is required to change to a different position if the switch receptor handle 14 is to be accessible.

[0058] Figure 17 depicts position 4. In position 4 the links 37a, 37b block the rotation of first and second shutters 39, 40 as the cranks 4 of the circuit breaker are as in the closed condition (as in figure 12b) and only the earth handle receptor 38 is accessible. The foregoing description is a specific embodiment of the present invention. It should be appreciated that this embodiment is described for purpose of illustration only, and that those skilled in the art may practice numerous alterations and modifications without departing from the scope of the invention. It is intended that all such modifications and alterations be included insofar as they come within the scope of the invention as claimed.

Claims

1. A switchgear comprising a mechanism for the synchronized operation of closing and opening of a vacuum bottle switching device and a selector device wherein said mechanism includes a switching device operating means and a selector operating means, **characterized in that** said mechanism further includes an earth operating means, each of said means having a handle receptor to accommodate a removable handle; said mechanism further comprising:

a first interlock arrangement for controlling access to either the switching device operating means or the selector operating means;

a second interlock arrangement for controlling access to either the selector operating means or the earth operating means;

a first link (37a) provided such that one end of said first link is in contact with a crank (4) of the switching device and the other end is in contact with the said first interlock arrangement;

a second link (37b) provided such that one end of said second link is in contact with a crank (4) of the switching device and the other end is in contact with the said second interlock arrangement;

said first and second interlock arrangements being configured such that upon insertion of said handle (18) into an accessible handle receptor (33,14,38) of any one of said selector operating means, switching device operating means or

earth operating means, the access to the remaining operating means is blocked.

2. The mechanism as claimed in claim 1, wherein said first and second interlock arrangements are spring-loaded shutters (39,40) pivoted on respective axis A,B. 5
3. The mechanism as claimed in claim 2, wherein said shutters are configured to partially cover the access to any of the switching device operating means, selector operating means and earth operating means at any instant. 10
4. The mechanism as claimed in claim 1, wherein a push button is provided to move the switching device from a closed position to an open position, the access to the selector operating means and the earth operating means being blocked. 15
5. The mechanism as claimed in claim 1, wherein, when the switching device is in the open position, the handle (18) is capable of being inserted either in the switch operating means to move the switching device to the closed position, or, in the selector operating means to move the switching device to a disconnect position. 20
6. The mechanism as claimed in claim 1, wherein, when the switching device is in the disconnect position the handle (18) is capable of being inserted either in the selector operating means to move the switching device to the open position, or, in the earth operating means to move the switching device to an earth position. 25
7. The mechanism as claimed in claim 1, wherein, when the switching device is in the earth position the handle (18) is capable of being inserted only in the earth operating means to move the switching device to the disconnect position. 30
8. The mechanism as claimed in claim 5 or 6, wherein five charging strokes of the handle are provided to move the switching device from open to close position and from the disconnect to earth position. 35
9. The mechanism as claimed in claim 7 or 8, wherein one stroke of the handle is provided in a direction opposite the charging stroke to move the switching device from the earth position to the disconnect position. 40
10. The mechanism as claimed in claim 1, wherein: 45

the interlock arrangement is configured to control access to the selector operating means in two positions since the selector operating

means has two stable states; and the interlock arrangement is configured to control access to the switching and/or earth operating means in one position since the switching and/or earth operating means has one stable state.

11. The mechanism as claimed in claim 1, wherein the first and second links are configured to indicate the open/close condition of the switching device for controlling the position of the interlock arrangement and access to the operating means. 50
12. The mechanism as claimed in claim 1, wherein the handle receptors (33,14,38) of the switching device operating means and the earth operating means are spring loaded to return to their initial position after handle operation. 55
13. The mechanism as claimed in claim 1, wherein the handle receptor (33,14,38) of the selector operating means has two positions depending on the line and earth condition of the selector device. 60

Patentansprüche

1. Elektrisches Schaltgerät mit einem Mechanismus zum synchronisierten Einschalten und Ausschalten einer Vakuum-Schalteinrichtung und einer Umschalteinrichtung, welcher Mechanismus Schalteinrichtungs-Betätigungsmittel und Umschalter-Betätigungsmittel umfasst, **dadurch gekennzeichnet, dass** der genannte Mechanismus zusätzlich einen Erdungs-Betätigungsmechanismus umfasst, wobei in jedem der genannten Mittel eine Aufnahme zur Einführung eines abnehmbaren Handgriffs ausgebildet ist und der genannte Mechanismus außerdem eine erste Verriegelungsanordnung zur steuern den Zugang zu den alternativen Steuerung der Schalteinrichtungs-Betätigungsmittel oder der Umschalter-Betätigungsmittel, eine zweite Verriegelungsanordnung zur alternativen Steuerung der Umschalter-Betätigungsmittel oder der Erdungs-Betätigungsmittel, ein erstes Verbindungselement (37a), das so ausgelegt ist, dass ein Ende des genannten ersten Verbindungselements an einer Kurbel (4) der Schalteinrichtung und das andere Ende an der genannten ersten Verriegelungsanordnung anliegt, sowie ein zweites Verbindungselement (37b), das so ausgelegt ist, dass ein Ende des genannten zweiten Verbindungselements an einer Kurbel (4) der Schalteinrichtung und das andere Ende an der genannten zweiten Verriegelungsanordnung anliegt, wobei die genannte erste und die genannte zweite Verriegelungsanordnung so ausgebildet sind, dass nach dem Einsetzen des genannten Handgriffs (18) in ei-

- ne zugängliche Aufnahme (33, 14, 38) irgendeines der Umschalter-Betätigungsmittel, der Schalteinrichtungs-Betätigungsmittel oder der Erdungs-Betätigungsmittel der Zugang zu den übrigen Betätigungsmitteln versperrt ist.
2. Mechanismus nach Anspruch 1, bei dem die genannte erste und zweite Verriegelungsanordnung als Federkraft-Verschlussysteme (39, 40) ausgebildet sind, die um eine Achse A, B verschwenkt werden.
3. Mechanismus nach Anspruch 2, bei dem die genannten Verschlussysteme so ausgebildet sind, dass sie jederzeit den Zugang zu irgendeinem der Schalteinrichtungs-Betätigungsmittel, der Umschalter-Betätigungsmittel und der Erdungs-Betätigungsmittel teilweise verdecken.
4. Mechanismus nach Anspruch 1, der einen Drucktaster umfasst, um die Schalteinrichtung von einer Ausschaltstellung in eine Einschaltstellung zu überführen, wobei der Zugang zu den Umschalter-Betätigungsmitteln und den Erdungs-Betätigungsmitteln gesperrt ist.
5. Mechanismus nach Anspruch 1, bei dem in der Ausschaltstellung der Schalteinrichtung der Handgriff (18) entweder in die Schalteinrichtungs-Betätigungsmittel zu deren Überführung in die Einschaltstellung oder in die Umschalter-Betätigungsmittel zu dessen Überführung in eine Trennstellung eingeführt werden kann.
6. Mechanismus nach Anspruch 1, bei dem in der Trennstellung der Schalteinrichtung der Handgriff (18) entweder in die Umschalter-Betätigungsmittel zur Überführung der Schalteinrichtung in die Ausschaltstellung oder in die Erdungs-Betätigungsmittel zur Überführung der Schalteinrichtung in eine Erdungsstellung eingeführt werden kann.
7. Mechanismus nach Anspruch 1, bei dem in der Erdungsstellung der Schalteinrichtung der Handgriff (18) nur in die Erdungs-Betätigungsmittel zur Überführung der Schalteinrichtung in die Trennstellung eingeführt werden kann.
8. Mechanismus nach Anspruch 5 oder 6, bei dem die Schalteinrichtung durch fünf Spannhübe des Handgriffs von der Ausschaltstellung in die Einschaltstellung und von der Trennstellung in die Erdungsstellung überführt wird.
9. Mechanismus nach Anspruch 7 oder 8, bei dem die Schalteinrichtung durch einen, in entgegengesetzter Richtung zum Spannhub ausgeführten Hub des Handgriffs von der Erdungsstellung in die Trennstellung

überführt wird.

10. Mechanismus nach Anspruch 1, bei dem die Verriegelungsanordnung so ausgebildet ist, dass sie den Zugang zu den Umschalter-Betätigungsmitteln in zwei Stellungen steuert, da die Umschalter-Betätigungsmittel zwei stabile Zustände aufweisen, und die Verriegelungsanordnung so ausgebildet ist, dass sie den Zugang zu den Schalteinrichtungs-Betätigungsmitteln und/oder den Erdungs-Betätigungsmitteln in einer Stellung steuert, da die Schalteinrichtungs-Betätigungsmittel und/oder die Erdungs-Betätigungsmittel einen stabilen Zustand aufweisen.
11. Mechanismus nach Anspruch 1, bei dem die ersten und die zweiten Verbindungselemente so ausgebildet sind, dass sie zur Steuerung der Stellung der Verriegelungsanordnung und des Zugangs zu den Betätigungsmitteln die Ausschalt-/Einschaltstellung der Schalteinrichtung anzeigen.
12. Mechanismus nach Anspruch 1, bei dem die Handgriffaufnahmen (33, 14, 38) der Schalteinrichtungs-Betätigungsmittel und der Erdungs-Betätigungsmittel einen Federkraftspeicher umfassen, um nach Betätigung des Handgriffs in ihre Ausgangslage zurückzukehren.
13. Mechanismus nach Anspruch 1, bei dem die Handgriffaufnahme (33,14,38) der Umschalter-Betätigungsmittel zwei Stellungen aufweist, die von der Betriebsstellung bzw. der Erdungsstellung des Umschalters abhängen.

Revendications

1. Appareil de coupure comprenant un mécanisme destiné à synchroniser les manoeuvres de fermeture et d'ouverture d'un dispositif de coupure à ampoule à vide, ainsi qu'un commutateur, dans lequel ledit mécanisme comprend des moyens de commande du dispositif de coupure ainsi que des moyens de commande du commutateur, **caractérisé en ce que** ledit mécanisme comprend en outre des moyens de mise à la terre, chacun desdits moyens étant pourvu d'un logement pour recevoir une manette amovible, ledit mécanisme comprenant en plus :
- un premier dispositif d'inter-verrouillage pour contrôler l'accès soit aux moyens de commande du dispositif de coupure soit aux moyens de commande du commutateur ;
- un deuxième dispositif d'inter-verrouillage pour contrôler l'accès soit aux moyens de commande du commutateur soit aux moyens de commande de la mise à la terre ;
- une première liaison (37a) prévue de manière à

- ce que l'une des extrémités de ladite première liaison soit en contact avec une manivelle (4) du dispositif de coupure et que l'autre extrémité soit en contact avec ledit premier dispositif d'inter-verrouillage ;
- une deuxième liaison (37b) prévue de manière à ce que l'une des extrémités de ladite deuxième liaison soit en contact avec une manivelle (4) du dispositif de coupure et que l'autre extrémité soit en contact avec ledit deuxième dispositif d'inter-verrouillage ;
- lesdits premier et deuxième dispositifs d'inter-verrouillage étant configurés de manière à ce que, lors de l'introduction de ladite manette (18) dans un logement de manette accessible (33,14,38) d'un quelconque desdits moyens de commande du commutateur, desdits moyens de commande du dispositif de coupure ou desdits moyens de commande de la mise à la terre, l'accès aux autres moyens de commande est bloqué.
2. Mécanisme selon la revendication 1, dans lequel lesdits premier et deuxième dispositifs d'inter-verrouillage sont formés par des volets à ressorts (39,40) pivotants sur des axes respectifs A,B. 25
 3. Mécanisme selon la revendication 2, dans lequel lesdits volets sont configurés de manière à recouvrir partiellement l'accès à tout moment à un quelconque des moyens de commande du commutateur, des moyens de commande du dispositif de coupure ou des moyens de commande de la mise à la terre. 30
 4. Mécanisme selon la revendication 1, dans lequel un bouton poussoir est prévu pour amener le dispositif de coupure d'une position fermée à une position ouverte, l'accès aux moyens de commande du commutateur et aux moyens de commande de la mise à la terre étant bloqué. 35
40
 5. Mécanisme selon la revendication 1, dans lequel, lorsque le dispositif de coupure se trouve dans la position ouverte, la manette (18) est capable de s'insérer soit dans les moyens de commande du dispositif de coupure pour amener le dispositif de coupure vers la position fermée, soit dans les moyens de commande du commutateur pour amener le commutateur vers une position de déconnexion. 45
 6. Mécanisme selon la revendication 1, dans lequel, lorsque le dispositif de coupure se trouve dans la position de déconnexion, la manette (18) est capable de s'insérer soit dans les moyens de commande du commutateur pour amener le commutateur vers la position ouverte, soit dans les moyens de commande de mise à la terre pour amener le dispositif de coupure vers une position de mise à la terre. 50
55
 7. Mécanisme selon la revendication 1, dans lequel, lorsque le dispositif de coupure se trouve dans la position de mise à la terre, la manette (18) est capable de s'insérer uniquement dans les moyens de commande de mise à la terre pour amener le dispositif de coupure vers la position de déconnexion. 5
 8. Mécanisme selon la revendication 5 ou 6, dans lequel cinq courses de chargement de la manette sont prévues pour amener le dispositif de coupure de la position ouverte à la position fermée et de la position de déconnexion vers la position de mise à la terre. 10
 9. Mécanisme selon la revendication 7 ou 8, dans lequel une course de la manette est prévue dans le sens contraire à la course de chargement pour amener le dispositif de coupure de la position de mise à la terre vers la position de déconnexion. 15
 10. Mécanisme selon la revendication 1, dans lequel : 20
 - le dispositif d'inter-verrouillage est configuré pour contrôler l'accès aux moyens de commande du commutateur dans deux positions, puisque les moyens de commande du commutateur ont deux états stables; et
 - le dispositif d'inter-verrouillage est configuré pour contrôler l'accès aux moyens de commande du dispositif de coupure et/ou de mise à la terre dans une seule position, puisque les moyens de commande du dispositif de coupure et/ou de mise à la terre ont un seul état stable.
 11. Mécanisme selon la revendication 1, dans lequel les premières et deuxième liaisons sont configurées de manière à signaler l'état ouvert/fermé du dispositif de coupure pour contrôler la position du dispositif d'inter-verrouillage ainsi que l'accès aux moyens de commande. 35
40
 12. Mécanisme selon la revendication 1, dans lequel les logements des manettes (33,14,38) des moyens de commande du dispositif de coupure et des moyens de commande du dispositif de mise à la terre sont pourvus de ressorts de rappel pour les amener vers leur position initiale après une manoeuvre de la manette. 45
 13. Mécanisme selon la revendication 1, dans lequel le logement de la manette (33,14,38) des moyens de commande du commutateur a deux positions selon que le commutateur soit connecté à la ligne ou à la terre. 50

Fig 1

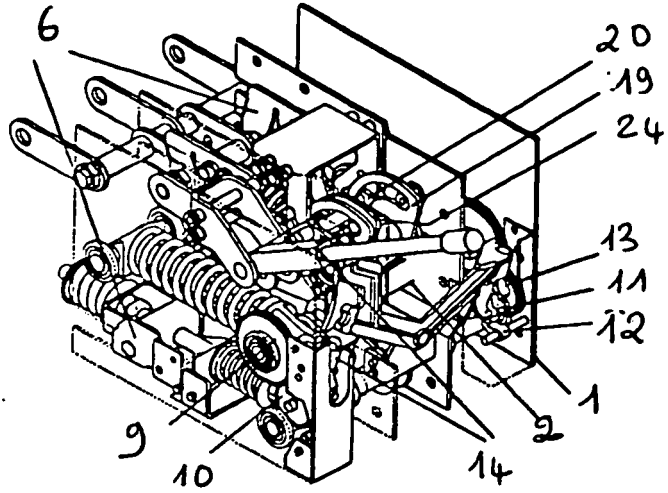

Fig 2

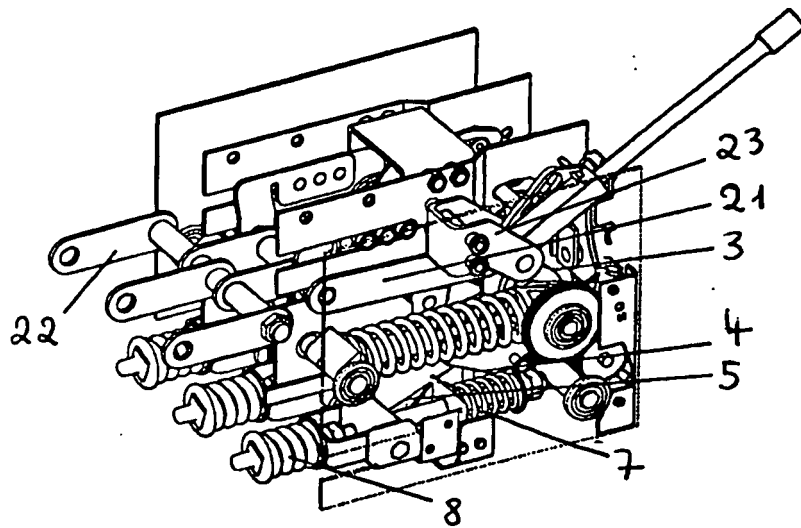

Fig 3

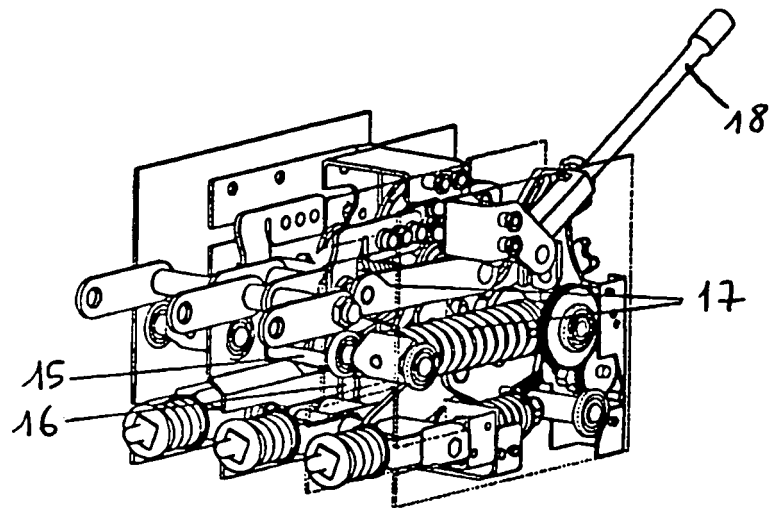
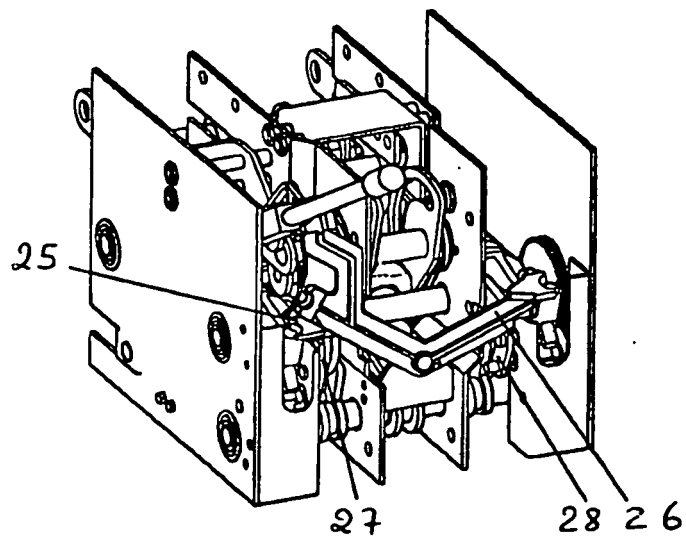

Fig 4



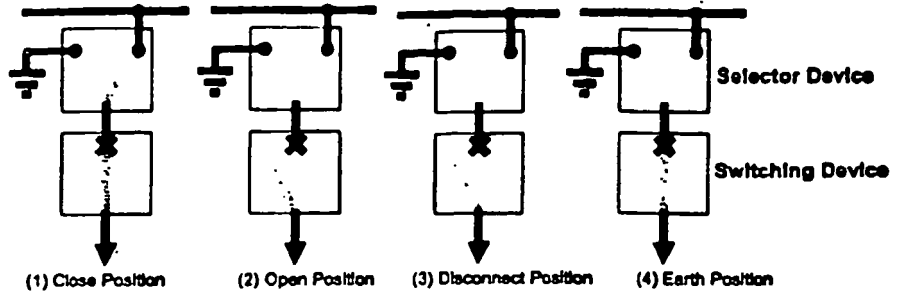

Fig 5a

Truth Table			
Position:	Disconnector	Circuit Breaker	Earthing
P1			
P2			
P3			
P4			

Legends:-

- Not Accessible
- Accessible Closed Position
- Accessible Open Position

Fig 5b

Fig 6a

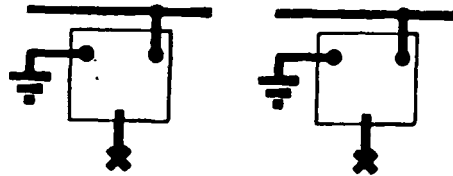

Fig 6b

Line Condition

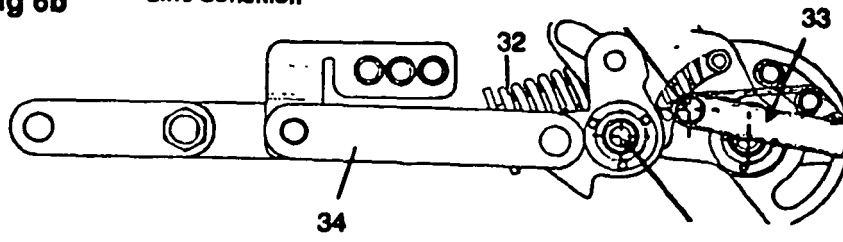

Fig 6c

Earth condition

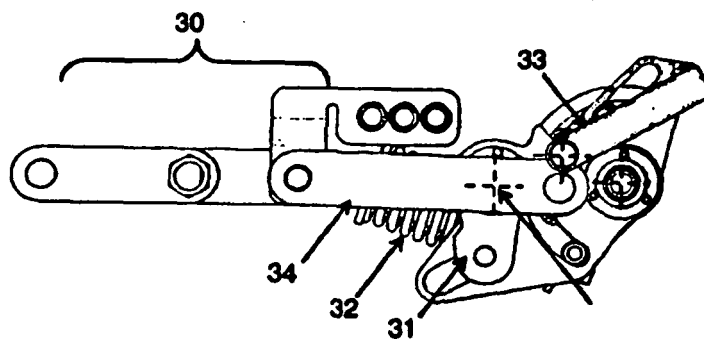

Fig 7a

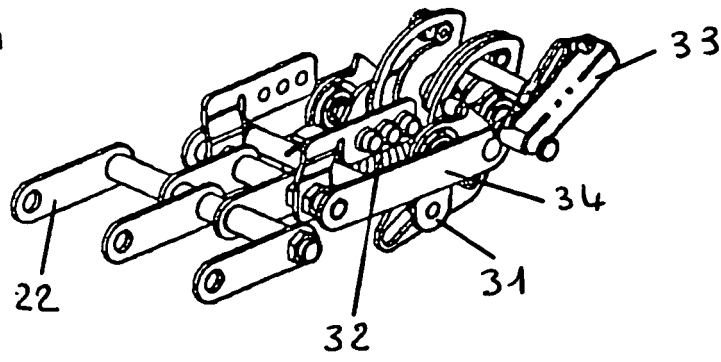
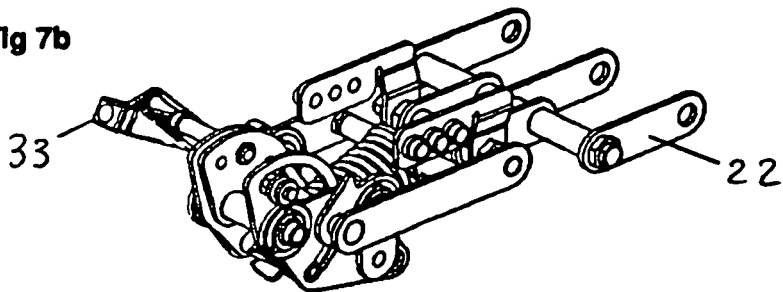

Fig 7b



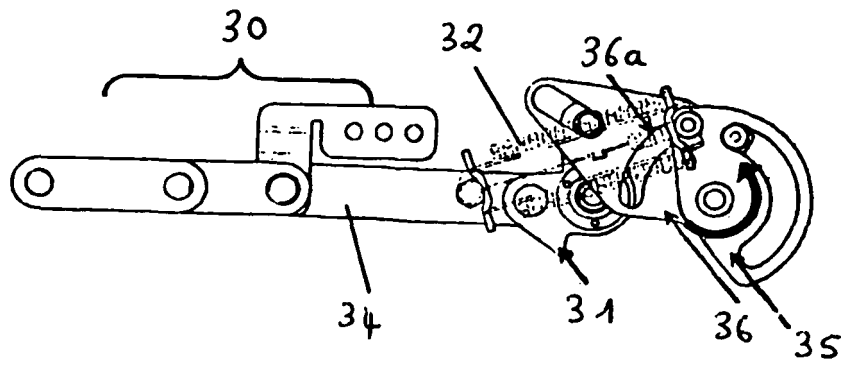

Fig. 8

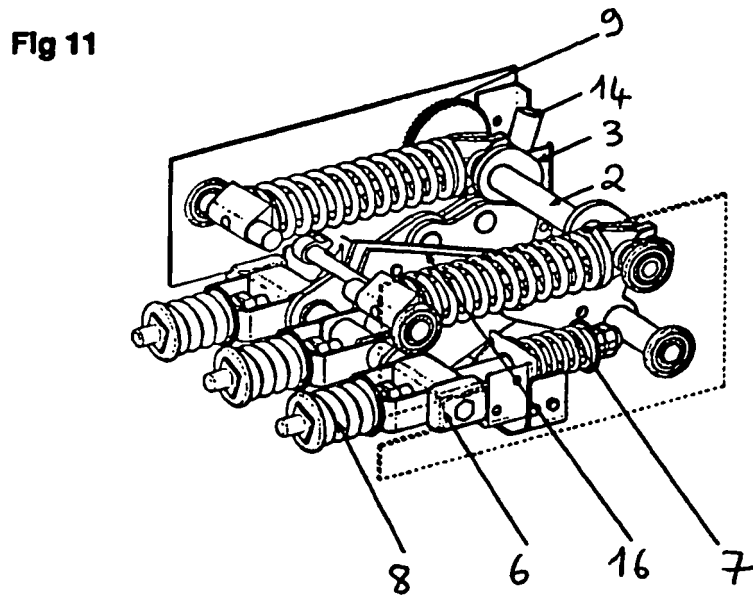
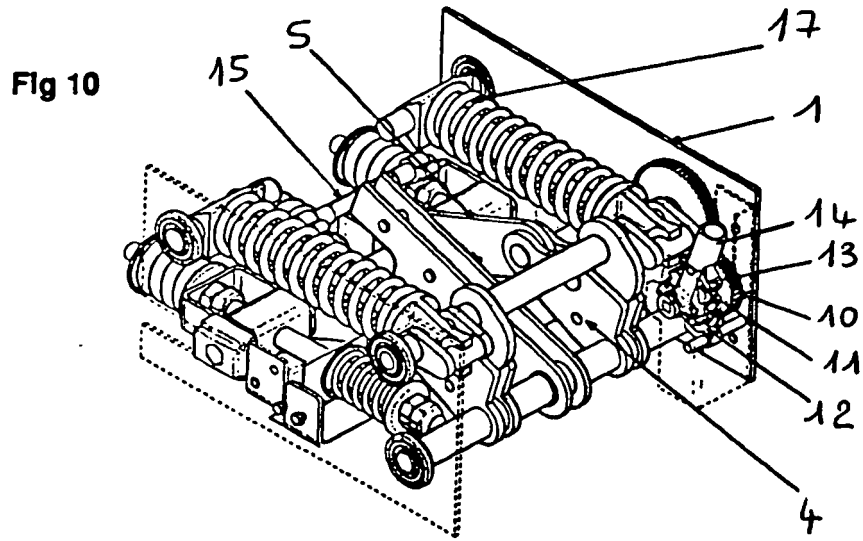
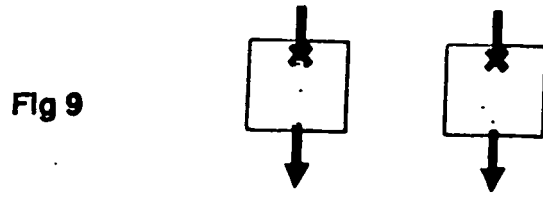

Fig 12a

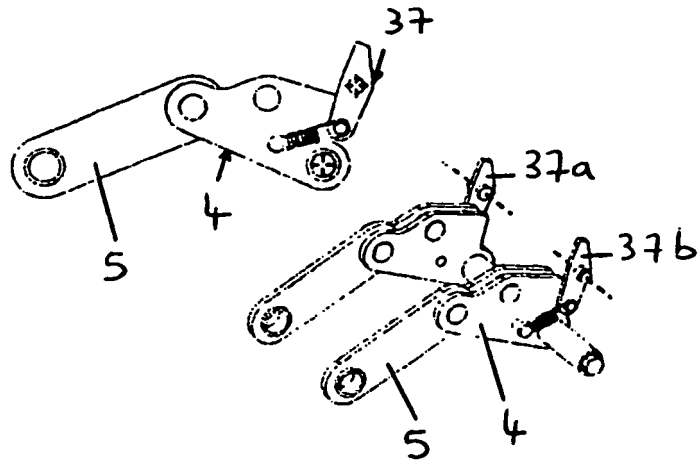

Fig 12b

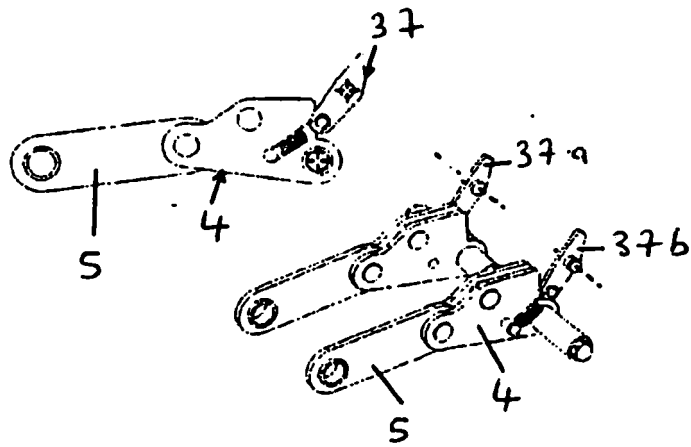

Fig 13a

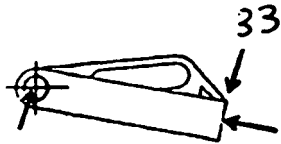

Fig 13b

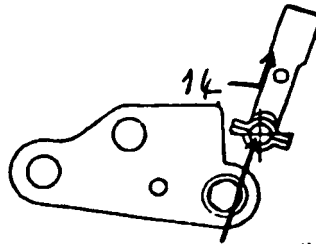

Fig 13c

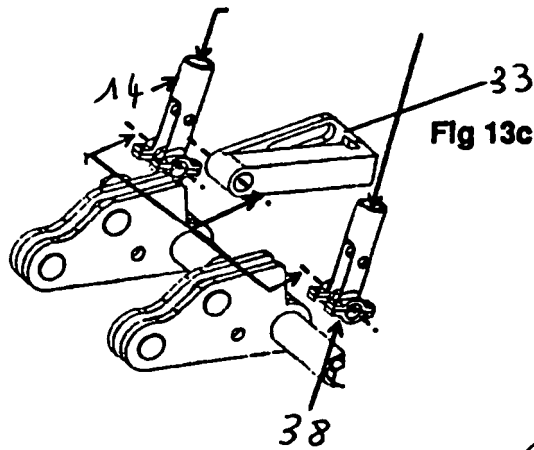
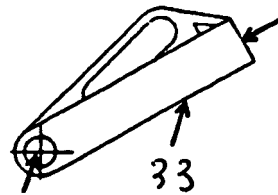

Fig 13d



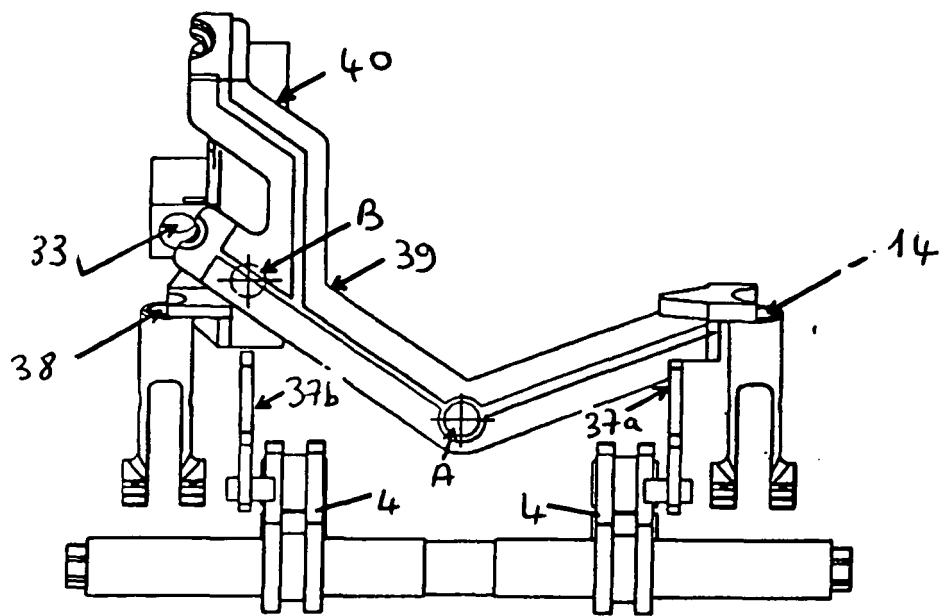

Fig 14

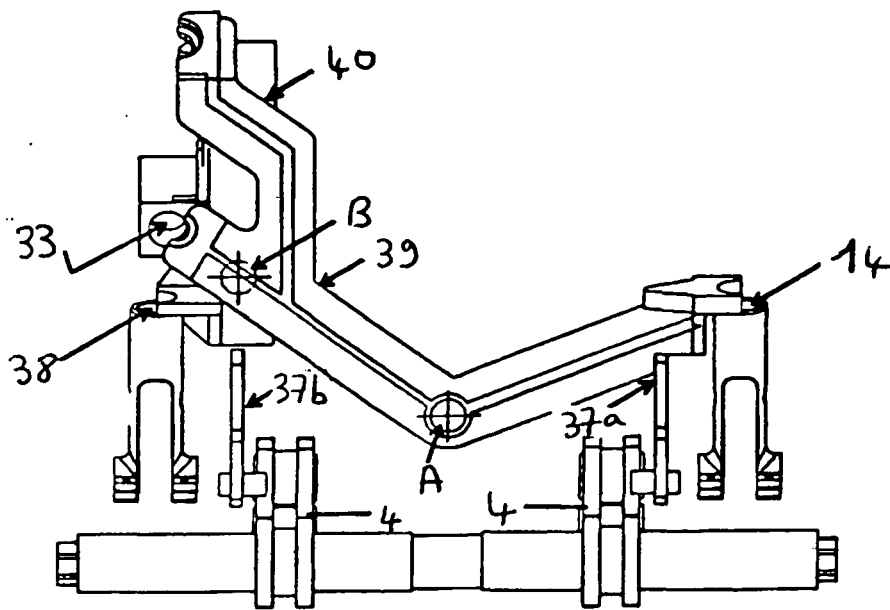

Fig 15

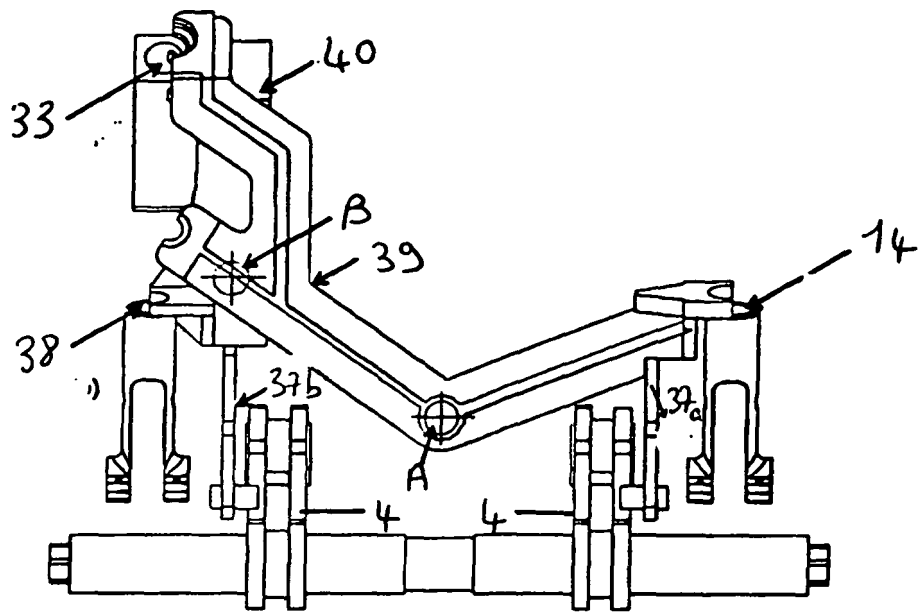

Fig 16

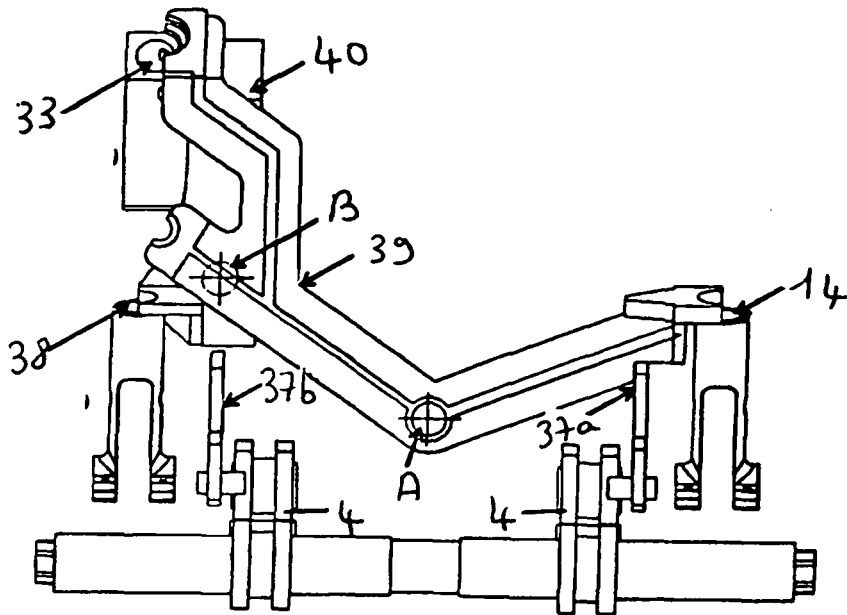

Fig 17

REFERENCES CITED IN THE DESCRIPTION

This list of references cited by the applicant is for the reader's convenience only. It does not form part of the European patent document. Even though great care has been taken in compiling the references, errors or omissions cannot be excluded and the EPO disclaims all liability in this regard.

Patent documents cited in the description

- US 3571543 A [0003]
- EP 1529299 B1 [0004]