



(11) **EP 2 196 597 B9**

(12) **CORRECTED EUROPEAN PATENT SPECIFICATION**

(15) Correction information:

**Corrected version no 1 (W1 B1)**

**Corrections, see**

**Claims DE 1, 7**

**Claims EN 1, 7**

**Claims FR 1, 7**

(51) Int Cl.:

**E04F 15/024 (2006.01)**

(48) Corrigendum issued on:

**25.07.2012 Bulletin 2012/30**

(45) Date of publication and mention of the grant of the patent:

**28.09.2011 Bulletin 2011/39**

(21) Application number: **09176830.9**

(22) Date of filing: **24.11.2009**

(54) **Supporting column for superelevated floors and production process**

Stützsäulen für überhöhte Böden und Herstellungsverfahren

Colonne de support pour planchers surélevés et procédé de production

(84) Designated Contracting States:

**AT BE BG CH CY CZ DE DK EE ES FI FR GB GR  
HR HU IE IS IT LI LT LU LV MC MK MT NL NO PL  
PT RO SE SI SK SM TR**

(30) Priority: **12.12.2008 IT MI20082195**

(43) Date of publication of application:

**16.06.2010 Bulletin 2010/24**

(73) Proprietor: **DIEFFECI S.r.l.**

**20060 Carugo (IT)**

(72) Inventor: **Donatiello, Gaetano**  
**20035, LISSONE (IT)**

(74) Representative: **Martegani, Franco**  
**Patent Attorney**  
**Via Carlo Alberto, 41**  
**20052 Monza (Milano) (IT)**

(56) References cited:

**DE-U1- 9 102 527 DE-U1- 29 604 339**  
**GB-A- 2 134 557 US-A- 4 557 086**

**EP 2 196 597 B9**

Note: Within nine months of the publication of the mention of the grant of the European patent in the European Patent Bulletin, any person may give notice to the European Patent Office of opposition to that patent, in accordance with the Implementing Regulations. Notice of opposition shall not be deemed to have been filed until the opposition fee has been paid. (Art. 99(1) European Patent Convention).

## Description

**[0001]** The present invention relates to some innovative improvements applied to a supporting column for modular superelevated floors and the relative production process.

**[0002]** The use of modular superelevated floors in the building industry allows a rapid and easy installation of the plant network system, in addition to the possibility of subsequently intervening non-invasively for maintenance, or for changing the arrangement of the network for example for adding a new working place. Interventions to the underlying plants can in fact be easily effected by raising one or more panels forming the modular floor and finally repositioning it to restore the floor.

**[0003]** Modular superelevated floors comprise a series of columns adjustable in height on which the panels are rested directly, or on which a framework structure which supports the panels is rested.

**[0004]** In addition to be finely adjustable in height, in order to obtain an optimum leveling of the superelevated floor regardless of the quality of the bottom, the supporting columns must satisfy other requisites.

**[0005]** First of all, the structure of the column must be capable of supporting the loads, even high, consisting of the panels, but above all what is resting on the floor. Floors are also subjected to vibratory stress which tends, for example, to loosen the height regulation means.

**[0006]** Furthermore, the column must be composed of a small number of components which are easy to assemble and have a reduced cost.

**[0007]** One known column suitable for this purpose is shown in DE29604339 in the name of RADTKE Manfred.

**[0008]** This column is provided by a screw which can be inserted into a tubular jamb.

**[0009]** A column of the known type is described and illustrated for example in Italian patent IT 1340094, to which reference should be made for viewing a product of the type briefly described above.

**[0010]** Columns of the known type are produced starting from:

- A round or square rough tube cut to the size from a rod with subsequent galvanizing and assembly of the tube on the resting base by means of various fixing systems;
- A round or square galvanized tube cut to the size from a rod with a subsequent washing operation from oils and chips and assembly of the tube on the supporting base by means of various fixing systems;
- A riveted tooth on the tube or creation of housings or assembly of a component on the top of the tube in order to guarantee the antirotation of the screwing nut of the threaded tie-rod by coupling with grooves or ridges present on the nut;
- A tube produced from an adjacent strip forming a cylindrical shape without a seaming but with the assembly of a containment ring in the upper part of the

tube necessary for preventing the opening of the same tube;

- A plastic bush which acts as a guide for the threaded tie-rod, assembled on the tube with an upper hooking crown outside the head of the tube.

**[0011]** A general objective of the present invention is to overcome the drawbacks of the known art, with particular reference to the production of a supporting column for modular superelevated floors having a perfected characteristic guiding system of the tie-rod in the tube.

**[0012]** A further objective of the invention is to provide a column produced so as to allow a reduction in the components in storage, at the same time allowing an almost immediate dispatch of the orders received from clients with lengths varying from millimeter to millimeter also without the necessity of subsequent treatment.

**[0013]** Another objective is to produce a column, object of the present invention, in an extremely simple, economical and particularly functional manner, if compared to columns of the known type, also reducing the processing phases.

**[0014]** In view of the above objectives, according to the present invention, a supporting column for modular superelevated floors has been conceived, together with a production process of said column, having the characteristics specified in the enclosed main claim and sub-claims.

**[0015]** The structural and functional characteristics of the present invention and its advantages with respect to the known art will appear even more evident from an examination of the following description, referring to the enclosed drawings, which show a supporting column for modular superelevated floors produced according to the innovative principles of the same invention.

**[0016]** In the drawings:

- figure 1 is a perspective view of a first embodiment of a supporting column for modular superelevated floors, object of the present invention;
- figure 2 is a cross-sectional perspective view of the column of figure 1;
- figure 3 is an exploded perspective view of the column of figure 1;
- figure 4 is a vertical section of the column of figure 1;
- figure 5 is a plan view of the jamb of figure 3;
- figure 6 is a raised view of the guiding bush of the threaded tie-rod (shank) for regulating the height of the column;
- figure 7 is a plan view of the bush of figure 6;
- figure 8 is a sectional view taken according to the traced section VIII-VIII of figure 7;
- figure 9 is a sectional view taken according to the traced section IX-IX of figure 7;
- figure 10 is a perspective view of the bush of figures 6-9;
- figure 11 is the same view as figure 10, but showing the guiding pass-through hole of the tie-rod;

- figure 12 is a cross-sectional perspective view illustrating the bush of figures 6-10 assembled inside the column;
- figure 13 is a plan view of the section of figure 12;
- figures 14-17 are the same views as figures 1-4, but illustrating a second embodiment of the invention without a guiding bush but with a guide of the tie-rod obtained by undercuts situated on the tube;
- figures 18, 19 and 20 each show (according to different views) the phase sequence of the production process of a supporting column for modular superelevated floors according to the invention;
- figure 21 is a perspective view illustrating a second possible embodiment of the tube of the column of figures 1-5; and
- figure 22 is an exploded perspective view of the column of figure 21.

**[0017]** With reference first of all to figures 1-4 of the drawings, a supporting column for modular superelevated floors in question is indicated as a whole with 10, and in the example illustrated, according to the present invention, comprises a lower resting base 11 and a top supporting element 12 destined for receiving floor panels (not shown), or a framework structure (also not shown), on which said panels are rested.

**[0018]** The element 12 comprises a supporting plate or flange 13 (suitably shaped) and a shank or threaded tie-rod 14, stably and inseparably integral with each other as better described in patent Nr. 1340094.

**[0019]** The supporting plate 13 can have generic forms and dimensions, it can consist, for example, of a flat metallic sheet or a series of radial spokes. The drawings show a non-limiting embodiment of the plate 13, equipped with a series of holes 15 and deep-drawn grooves 16 suitable for allowing a versatile coupling with the floor panels, or with the supporting framework, and anti-noise, antistatic or conductive washers (not shown).

**[0020]** In particular, the supporting plate 13 has a collar or sleeve 17 to which the above tie-rod 14 is firmly fixed in any of the known ways.

**[0021]** The shank or tie-rod 14 can be threaded for its whole length and is obtained, for example, as a piece from a threaded bar, cut into the desired size to produce columns 10 of differing heights.

**[0022]** The top support 12 (in the form of the plate 13) is constrained to the resting base 11 by threaded coupling means, so that the height of the column 10 can be accurately regulated.

**[0023]** According to a possible embodiment of the invention, shown in figures 1-12, for illustrative and non-limiting purposes, the resting base 11 comprises a lower plate 18 for resting on the ground and a hollow tubular body or jamb 19, firmly constrained at its lower end to the plate 18 (as explained hereunder), and equipped at the upper free end with a guiding bush 20 of the tie-rod 14.

**[0024]** A blocking element 21, for example a hexagonal nut equipped with a series of centering elements 22 com-

plementary to centering elements 23 attached to the free top of the jamb 19, is screwed onto the shank or threaded tie-rod 14.

**[0025]** The engagement between these complementary centering elements 22, 23, prevents the rotation of the blocking nut 21.

**[0026]** As clearly illustrated in figure 5, and also with reference to figures 18-20 illustrating the phase sequence of the production method of the supporting column according to the invention, the tubular jamb 19 has a polygonal transversal section, preferably but not necessarily substantially square, joined at the corners.

**[0027]** Again according to the present invention, said jamb 19 consists of at least one piece 24 of a strip of sheet, bent so as to bring the two free longitudinal edges 25, 26 of the strip 24 in correspondence with each other, said two edges 25, 26 being rigidly interconnected by means of a seaming 27 (figure 5).

**[0028]** Said seaming 27 substantially relates to the whole height of the jamb 19, and comprises a toothed section 28 on an edge of the strip 24 and a hooking section 29 on the other edge, said hooking section 29 being hooked onto said toothed section 28.

**[0029]** In the enlargement of figure 5, the presence of an undercut 29' is clearly illustrated in the section 29, in which the section 28 having a corresponding configuration for this purpose, is engaged.

**[0030]** In addition, on the piece of sheet strip 24 there are a series of ribbings 30, 30', obtained by deep-drawing, for tightening the tubular jamb 19 and guiding the threaded tie-rod 14, in the absence of the bush 20, which is assembled on the same ribbings 30, as explained hereunder.

**[0031]** With particular reference to figures 6-13, the guiding bush 20 of the tie-rod 14 is made of a plastic material, it has a perimetric section 31, with a substantially polygonal plane, corresponding to the internal plane of the jamb 19, and a circular internal section 32 substantially corresponding to the diameter of the tie-rod 14 that it guides.

**[0032]** As can be clearly seen from the drawings, said bush 20 is formed with a cut edge in order to define a flat external surface 33, which exactly fits the internal area 34 in correspondence with the seaming 27, whereas the other three surfaces have cavities 35, which are forcedly coupled with the deep-drawn ribbings 30 extending internally from the column 19.

**[0033]** It is clear (figures 12, 13) how the bush 20 can be forcedly inserted through the top of the column 19 and firmly blocked in place, in order to exert its safe guiding function of the threaded tie-rod 14.

**[0034]** As already specified, however, and as clearly illustrated in the further embodiment shown (with the same reference numbers) in figures 15-17, the bush 20 can be absent and the threaded tie-rod 14 can be suitably guided by the same ribbings 30, protruding internally from the tubular column 19.

**[0035]** In both embodiments, the ribbings 30', in cor-

respondence with the base of the tubular column 19, also have the purpose of enabling the insertion and forced blockage of the same column on a central cylindrical shank 36 extending vertically from the lower resting base 11.

[0036] Finally, with reference to figures 21, 22, according to a further possible embodiment of the invention, the tubular column 19, instead of being produced in a single piece of sheet plate 25, as shown in figures 18, 19, 20, can be produced starting from two pieces 37, 38.

[0037] The column according to the invention can be advantageously produced with the process schematized in figures 18-20, starting from a piece 24 cut from a strip of sheet.

[0038] As can be clearly seen from figures 18-20, the piece 24 is first deep-drawn into 30, 30', then shaped on the edges so as to define the sections 28, 29, bent into tubular form with a polygonal section, and finally the sections 28, 29 are joined together by means of seaming 27.

[0039] As clearly illustrated in figures 21, 22 on both the free edges of the piece 37 bent to an angle, there is a hook section 29, whereas there is a toothed section 28 on both of the free edges of the other piece 38.

[0040] The coupling between the two pieces 37, 38 is effected by hooking and seaming the hook sections 29 onto the toothed sections 28, as shown in figure 21.

[0041] The advantages of a supporting column for super-elevated floors produced according to the present invention will appear evident to experts in the field from the above description with reference to the drawings, and are briefly the following:

- Possibility of using quality materials and different thicknesses without adapting the product to commercial tube standards.
- Possibility of using pre-galvanized material and therefore with internal and external galvanizing and elimination of the washings or galvanizing typically necessary after the shear processing of the tube.
- Possibility of rapidly producing tubes having varying lengths, from a strip, with a reduced necessity for storage and with possible on-line assembly.
- Possibility of freely defining the forms of the product and processing the strip horizontally to create, for example, intermediate hooking points for accessories or ribbings.
- Possibility of producing tubes with calibrated housings for tie-rods and narrow coupling clearances without subsequent operations with the creation of 4 or more internal resting points and a consequent reduction in the allowances.
- Possibility of directly producing various hooking forms on the tube for assembly on other typical components (for example: resting base and nuts).
- Anti-rotation tooth of the nut which can be obtained from the solid part without additional processing after the forming of the tube and without costly material scraps.

- Possibility of the assembly of an internal plastic bush without further processing of the tube with housing inside the tube and vertical hold without the necessity of an upper head.
- Elimination of typical bar-end scraps (non-multiple shear size of the tube of 6 mm) and of the shear blade wastage (mm<sup>2</sup>) with a reduction in the overall processing wastage.
- Absence of internal weld beads which disturb the run of the tie-rod.
- Mechanical seaming and formation of folding ribbings which guarantee resistance to loads without the addition of components for radial support.
- Sealing of the tube obtained with coinage of the outer tooth for the creation of an undercut which prevents the outer tooth (section 29) from slipping away from the inner tooth (section 28).
- Mechanical seaming contained in the maximum external encumbrance of the square for possible non-oriented couplings with other components.
- Seaming form with resting of the circle 42 of the tie-rod on the internal point 40 and not 39 such as to create thrusts on the internal tooth (section 28) towards the external tooth (section 29) and non-thrusts on the external tooth in the distancing direction 41 from the internal tooth.
- Internal undercuts (section 30) with resting points of the circle which are such as to not create direct thrusts on the external tooth in the direction 41.
- Formation of the seamed tube also in two assembled pieces.

[0042] The forms of the supporting column for modular super-elevated floors of the invention, as also the materials, can naturally differ from those shown for purely illustrative and non-limiting purposes in the drawings.

[0043] The protection scope of the invention is therefore delimited by the enclosed claims.

#### Claims

1. A supporting column for super-elevated floors comprising a supporting base (12), a top supporting element (13) and threaded coupling elements (14, 21) for regulating the height of said column (10), said column including a tubular jamb (19) having a polygonal transversal section, said jamb (19) consisting of at least one piece of a strip of bent sheet (24) so as to hold the two free longitudinal edges (25, 26) of the strip (24) corresponding to each other, said two edges (25, 26) being rigidly interconnected by means of seaming (27), **characterized in that** said piece of sheet strip (25) has calibrated guiding ribbings (30, 30') for reducing the coupling clearances with allowances lower than those typical of the tube; wherein a guiding bush (20) of a threaded tierod (14) which screws onto a nut (21) constrained to the top

of said jamb (19) is applicable by hooking onto said ribbings (30, 30').

2. The column according to claim 1, **characterized in that** said seaming (27) can substantially extend along the whole height of said jamb (19) 5
3. The column according to claim 1, **characterized in that** said jamb (19) consists of two pieces (37, 38) of a strip of sheet, bent and rigidly interconnected, in correspondence with the respective free edges by means of said seaming. 10
4. The column according to claim 1, **characterized in that** said seaming comprises a toothed section (28) on one edge of the strip and a hooking section (29) on the other edge, and an undercut (29') whose hooking section (29) can be hooked onto said toothed section (28). 15
5. The column according to claim 1 **characterized in that** at one end of said piece of sheet strip (24), anti-rotation teeth of said nut (21) are obtained from shearing with no scraps, on which the threaded tie-rod (14) for the regulation of the height of the column, is screwed, said nut (21) having cavities (22) which are coupled with said teeth (23). 20
6. The column according to claims 1, **characterized in that** it is inserted with interference by means of said ribbings (30') on a cylindrical shank (36) protruding from said supporting base (11). 25
7. A process for the production of a column (10) according to any of the claims 1-6, **characterized in that** said jamb (19) is produced through the following phases: 30
  - shearing at least one piece of a strip (24) of sheet having a length varying from millimetre to millimetre; 35
  - drawing said ribbings (30, 30') having an adjustable height on said piece of strip (24); 40
  - obtaining, on the two free edges (25, 26) of said piece of strip (24), said tooth (28) and hooking (29) sections respectively, of said seaming (27); 45
  - bending said piece of strip so as to define said jamb (19) having a polygonal section; 50
  - and
  - seaming together said tooth (28) and hooking (29) sections.
  - Blocking the seaming and centesimal calibration of the ribbings by internal punches. 55
8. The process according to claim 7 **characterized in that** said jamb (19) comprises two pieces (37, 38)

of sheet strips which have been sheared, drawn and bent, and wherein the free edges of one piece have toothed sections (28), whereas the free edges of the other piece have hooking sections (29).

#### Patentansprüche

1. Stützsäule für überhöhte Böden, umfassend eine Stützbasis (12), ein oberseitiges Stützelement (13) und Gewindekopplungselemente (14, 21) zum Regulieren der Höhe der Säule (10), wobei die Säule einen röhrenförmigen Pfosten (19) mit einem kantigen Querprofil aufweist, wobei der Pfosten (19) aus zumindest einem Teil eines Streifens aus gebogenem Blech (24) besteht, um **dadurch** die zwei freien Längsränder (25, 26) des Streifens (24) zu halten, die einander entsprechen, wobei die zwei Ränder (25, 26) mittels einer Falzung (27) starr verbunden sind, **dadurch gekennzeichnet, dass** das Teil des Blechstreifens (25) kalibrierte Führungsrippen (30, 31') zum Verringern der Kopplungsabstände aufweist, wobei die Zwischenräume kleiner als diejenigen sind, die für das Rohr typisch sind; wobei eine Führungshülse (20) einer Gewindezugstange (14), auf die eine Mutter (21) geschraubt ist, die an der Oberseite des Pfostens (19) gehalten ist, durch Einhaken in die Rippen (30, 30') anwendbar ist. 10
2. Säule nach Anspruch 1, **dadurch gekennzeichnet, dass** sich die Falzung (27) im Wesentlichen entlang der gesamten Höhe des Pfostens (19) erstrecken kann. 15
3. Säule nach Anspruch 1, **dadurch gekennzeichnet, dass** der Pfosten (19) aus zwei Teilen (37, 38) eines Streifens aus Blech besteht, die gebogen und in Übereinstimmung mit den jeweiligen freien Rändern mittels der Falzung starr verbunden sind. 20
4. Säule nach Anspruch 1, **dadurch gekennzeichnet, dass** die Falzung einen gezahnten Abschnitt (28) an einem Rand des Streifens und einen einhakenden Abschnitt (29) an dem anderen Rand sowie einen Hinterschnitt (29') umfasst, dessen einhakender Abschnitt (29) an dem gezahnten Abschnitt (28) eingehakt werden kann. 25
5. Säule nach Anspruch 1, **dadurch gekennzeichnet, dass** an einem Ende des Teils des Blechstreifens (24) mittels Scheren ohne Bruchstücke Zähne als Verdrehsicherung der Mutter (21) erzeugt werden, die auf die Gewindezugstange (14) zum Regulieren der Höhe der Säule geschraubt ist, wobei die Mutter (21) Aussparungen 30

(22) aufweist, die mit den Zähnen (23) gekoppelt sind.

6. Säule nach Anspruch 1, **dadurch gekennzeichnet, dass** diese mit Überlagerung mittels der Rippen (30') in einen zylindrischen Schaft (36) eingefügt ist, der von der Stützbasis (11) hervorsteht.

7. Verfahren für die Herstellung einer Säule (10) nach einem beliebigen der Ansprüche 1 bis 6, **dadurch gekennzeichnet, dass** der Pfosten (19) durch die folgenden Phasen hergestellt wird:

- Scheren zumindest eines Teils eines Streifens (24) aus Blech mit einer Länge, die von Millimeter zu Millimeter variiert;
- Tiefziehen der Rippen (30, 30'), die eine einstellbare Höhe an dem Teil des Streifens (24) aufweisen;
- Erzeugen der Zähne (28) bzw. der einhakenden Abschnitte (29) der Falzung (27) an den zwei freien Rändern (25, 26) des Teils des Streifens (24);
- Biegen des Teils des Streifens derart, dass der Pfosten (19) mit einem polygonalen Profil definiert wird; und
- Zusammenfalten der Zahnabschnitte (28) und der einhakenden Abschnitte (29);
- Verriegeln der Falzung und einer zentesimalen Kalibrierung der Rippen von innen durch Tiefziehstempel.

8. Verfahren nach Anspruch 7, **dadurch gekennzeichnet, dass** der Pfosten (19) zwei Teile (37, 38) von Blechstreifen umfasst, die geschert, tiefgezogen und gebogen wurden, und wobei die freien Ränder des einen Teils gezahnte Abschnitte (28) aufweisen, wohingegen die freien Ränder des anderen Teils einhakende Abschnitte (29) aufweisen.

## Revendications

1. Colonne de support pour planchers surélevés comprenant une base de support (12), un élément de support supérieur (13) et des éléments d'accouplement filetés (14, 21) pour régler la hauteur de ladite colonne (10), ladite colonne comprenant une jambe tubulaire (19) de section polygonale, ladite jambe (19) étant constituée d'au moins une pièce faite à partir d'une bande de tôle courbée (24) de manière à retenir les deux bords longitudinaux libres (25, 26) de la bande (24) correspondant l'un à l'autre, lesdits deux bords (25, 26) étant interconnectés de façon rigide au moyen d'un sertissage (27), **caractérisée en ce que** ladite pièce de bande de

tôle (25) comporte des nervurages de guidage calibrés (30, 30') pour réduire les jeux d'accouplement avec des tolérances inférieures à celles qui sont caractéristiques du tube ;

une douille de guidage (20) d'une tige filetée (14) qui se visse sur un écrou (21) contraint au sommet de ladite jambe (19) peut être montée par accrochage sur lesdits nervurages (30, 30').

2. Colonne selon la revendication 1, **caractérisée en ce que** ledit sertissage (27) peut s'étendre substantiellement sur toute la hauteur de ladite jambe (19).

3. Colonne selon la revendication 1, **caractérisée en ce que** ladite jambe (19) est constituée de deux pièces (37, 38) d'une bande de tôle, courbées et interconnectées de façon rigide, en correspondance avec les bords libres respectifs au moyen dudit sertissage.

4. Colonne selon la revendication 1, **caractérisée en ce que** ledit sertissage comprend une section dentée (28) sur un bord de la bande et une section d'accrochage (29) sur l'autre bord, et un dégagement (29') dont la section d'accrochage (29) peut être accrochée sur ladite section dentée (28).

5. Colonne selon la revendication 1, **caractérisée en ce que**, à une extrémité de ladite pièce de bande de tôle (24), des dents anti rotation dudit écrou (21) sont obtenues à partir d'un cisailage sans déchets, sur lequel est vissée la tige filetée (14) pour le réglage de la hauteur de la colonne, ledit écrou (21) comportant des cavités (22) qui sont accouplées auxdites dents (23).

6. Colonne selon la revendication 1, **caractérisée en ce qu'elle** est insérée avec serrage au moyen desdits nervurages (30') sur un pied cylindrique (36) faisant saillie depuis ladite base de support (11).

7. Procédé de production d'une colonne (10) conforme à l'une quelconque des revendications 1 à 6, **caractérisé en ce que** ladite jambe (19) est produite à travers les phases suivantes :

- cisailage d'au moins une pièce d'une bande (24) de tôle ayant une longueur variant de millimètre en millimètre ;
- tirage desdits nervurages (30, 30') ayant une hauteur réglable sur ladite pièce de bande (24) ;
- obtention, sur les deux bords libres (25, 26) de ladite pièce de bande (24), respectivement desdites sections de dents (28) et d'accrochage (29) dudit sertissage (27) ;
- cintrage de ladite pièce de bande pour définir ladite jambe (19) de section polygonale ; et
- sertissage desdites sections de dents (28) et

d'accrochage (29) entre elles ;  
- blocage du sertissage et de l'étalonnage centésimal des nervurages par des poinçons internes.

8. Procédé selon la revendication 7, **caractérisé en ce que** ladite jambe (19) comprend deux pièces (37, 38) de bandes de tôle qui ont été cisailées, tirées et cintrées, et dans lequel les bords libres d'une pièce comportent des sections dentées (28), tandis que les bords libres de l'autre pièce comportent des sections d'accrochage (29).

5

10

15

20

25

30

35

40

45

50

55

Fig. 1

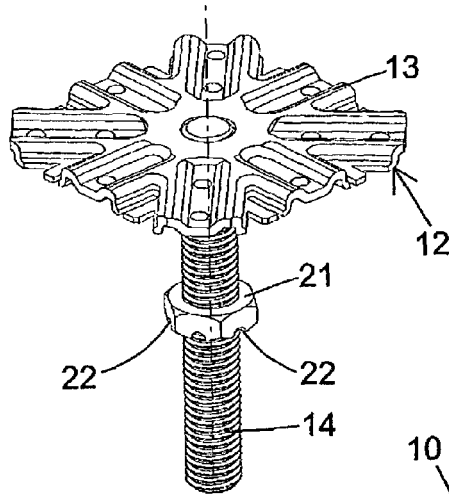
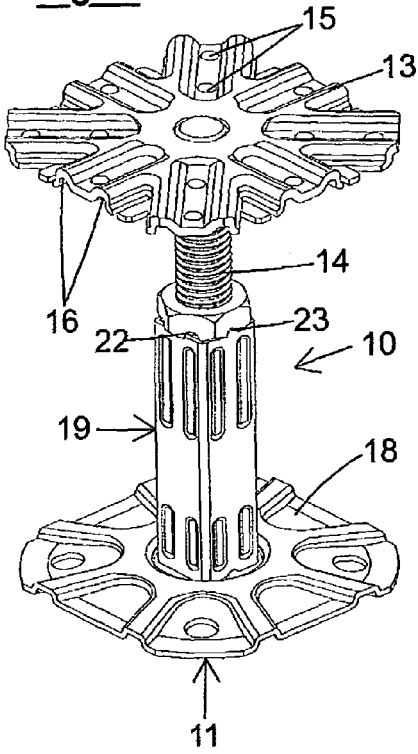

Fig. 2

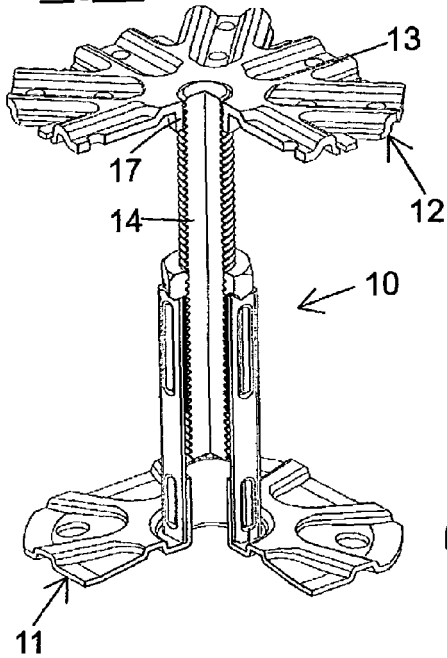

Fig. 3

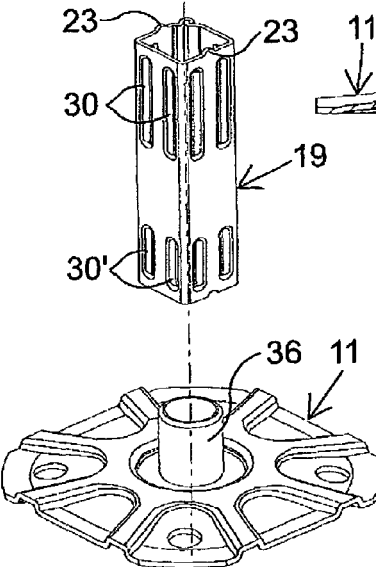

Fig. 4

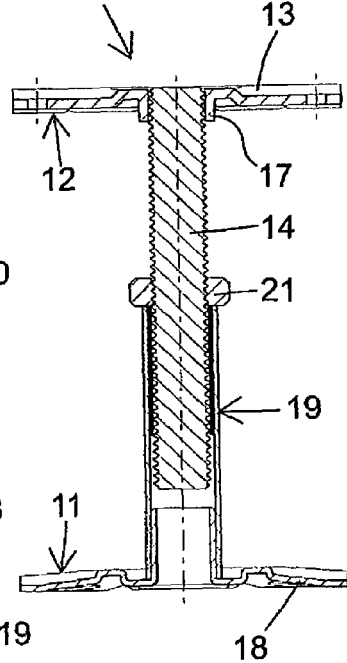

Fig. 5

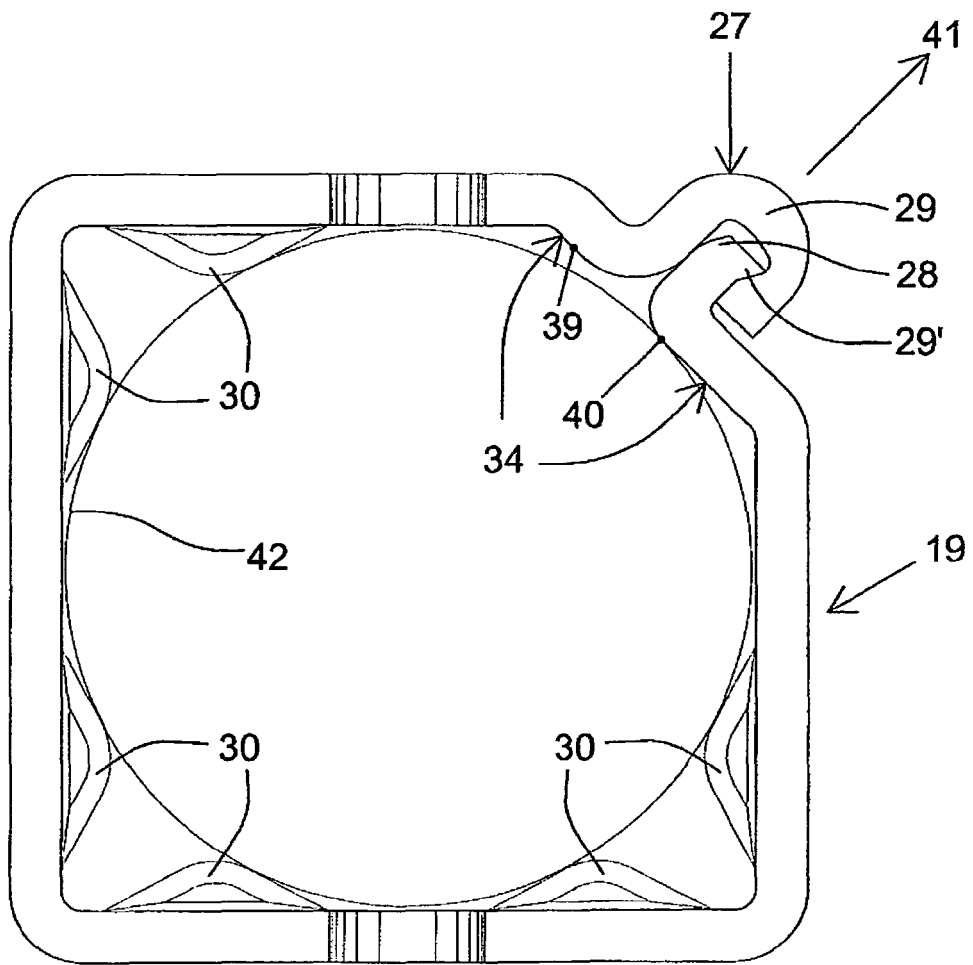

Fig. 6

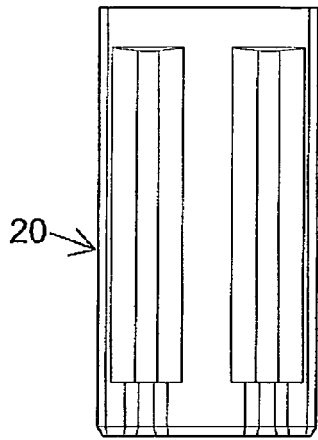

Fig. 7

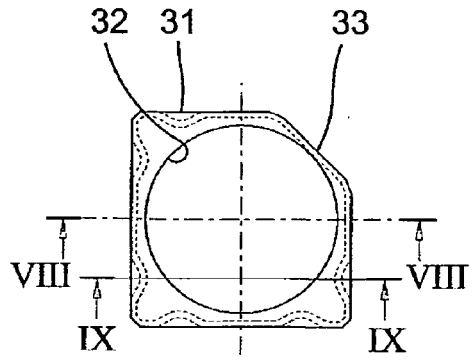

Fig. 8

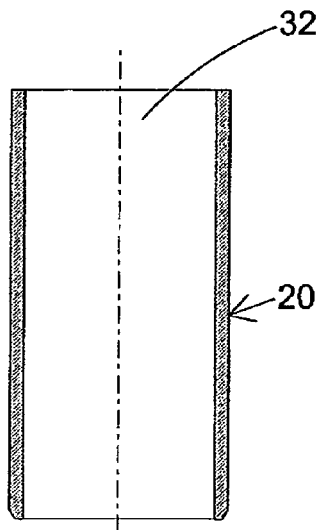

Fig. 9

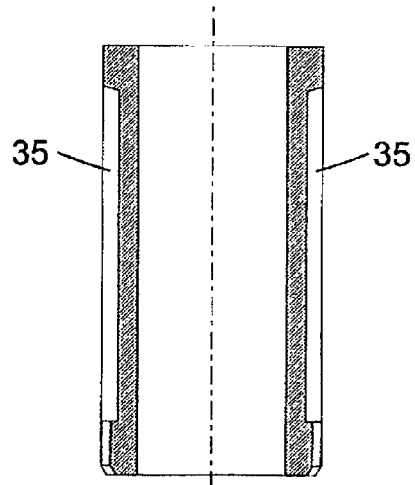

Fig. 10

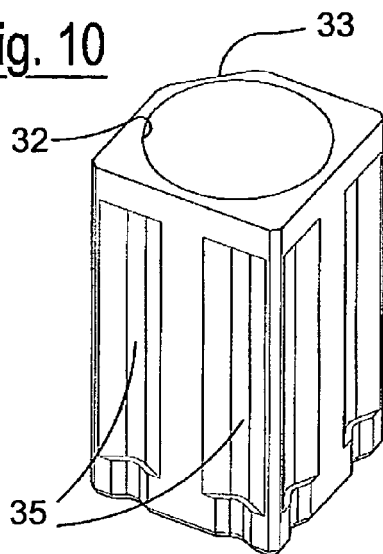

Fig. 11

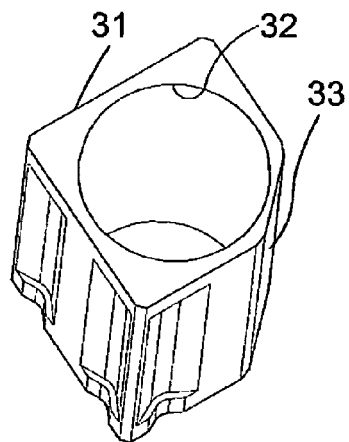

Fig. 12

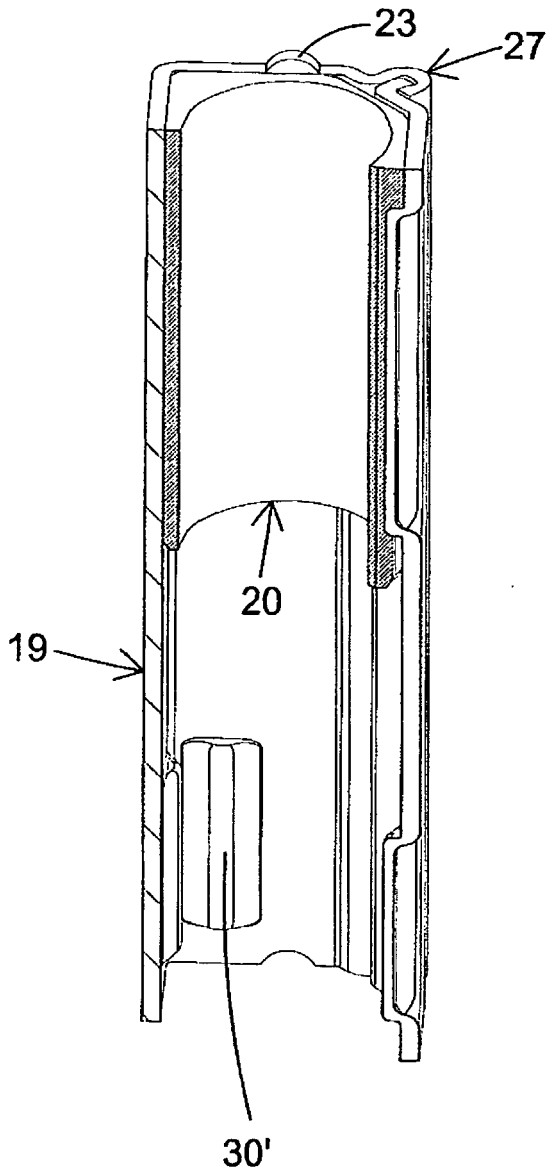

Fig. 13

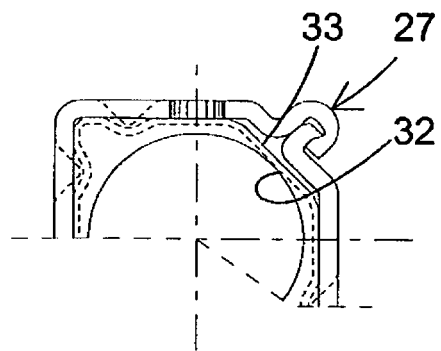

Fig. 14

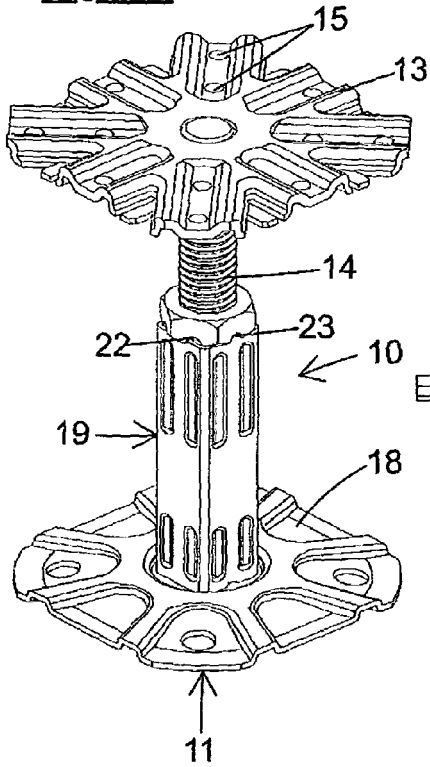

Fig. 17

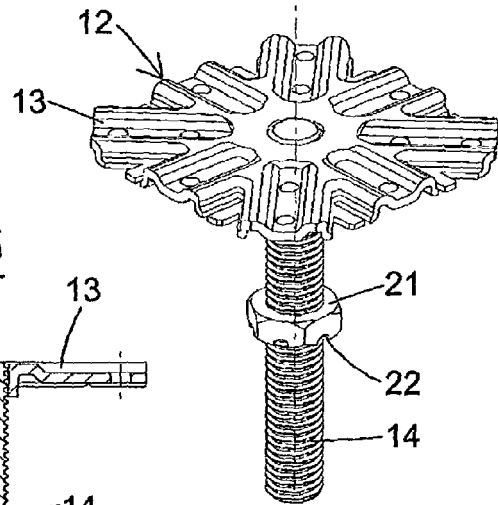

Fig. 16

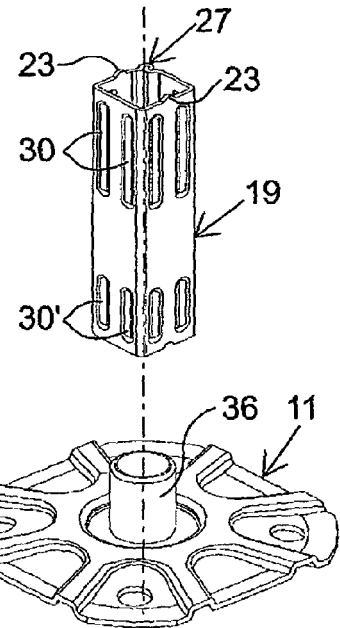
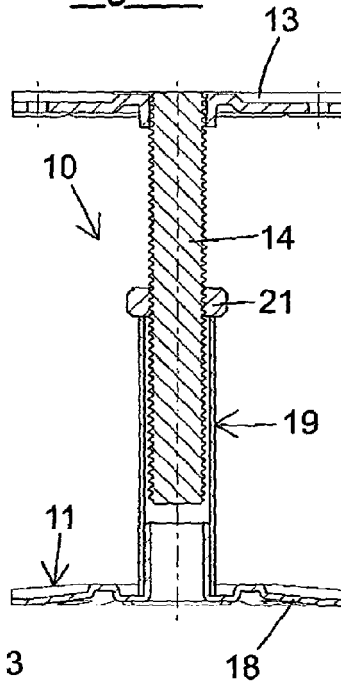

Fig. 15

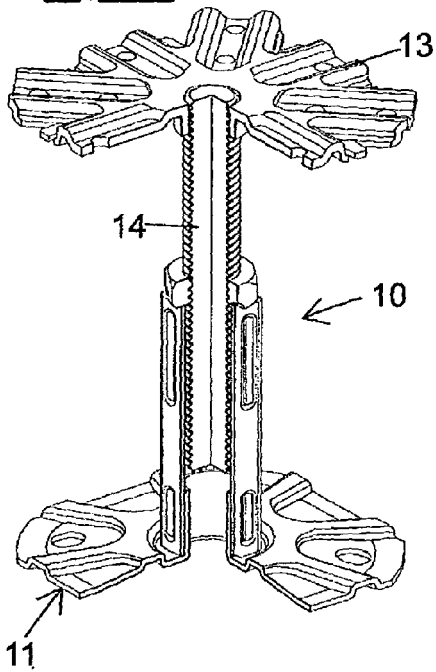
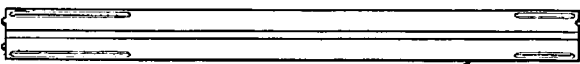
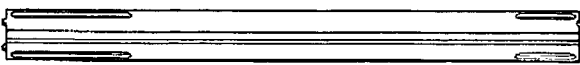
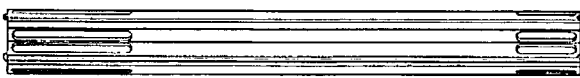
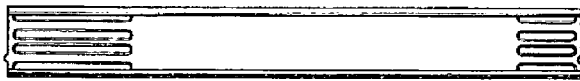
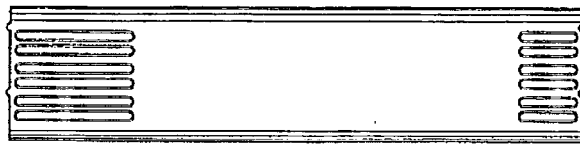
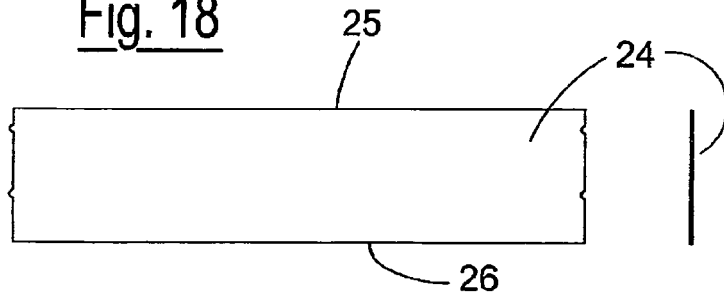

Fig. 18



19

Fig. 19



Fig. 20

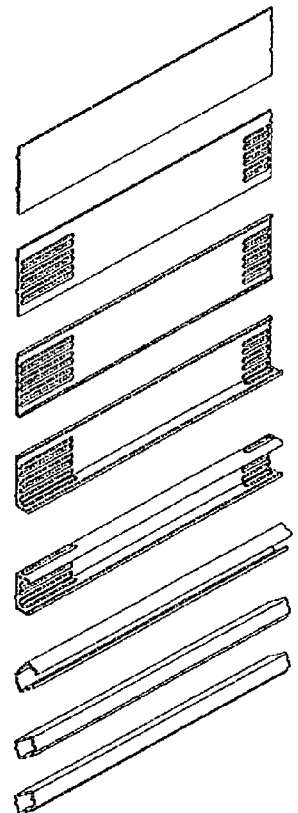

Fig. 21

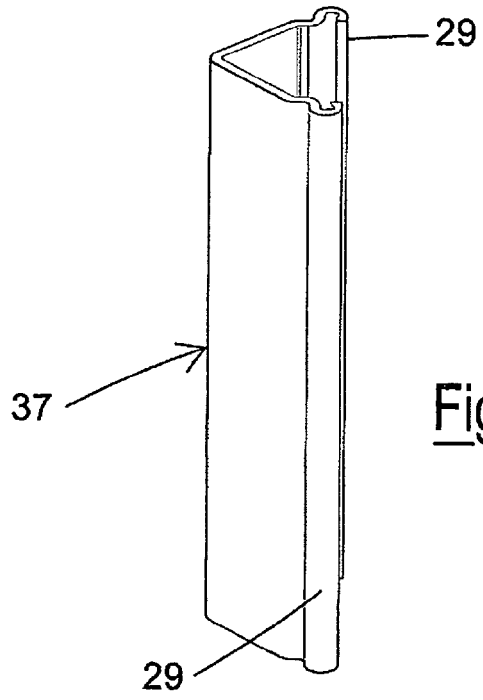
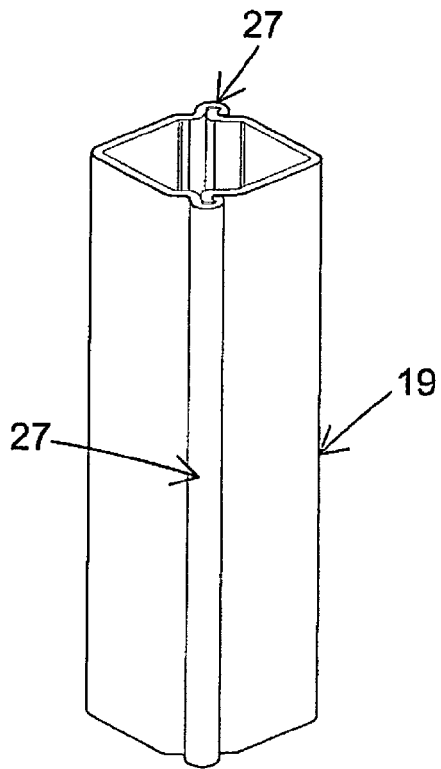
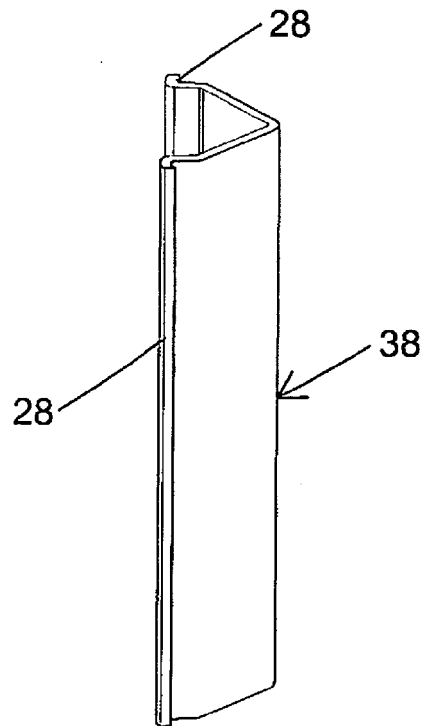

Fig. 22



**REFERENCES CITED IN THE DESCRIPTION**

*This list of references cited by the applicant is for the reader's convenience only. It does not form part of the European patent document. Even though great care has been taken in compiling the references, errors or omissions cannot be excluded and the EPO disclaims all liability in this regard.*

**Patent documents cited in the description**

- DE 29604339 [0007]
- IT 1340094 [0009]
- WO 1340094 A [0018]