

(19)



(11)

**EP 2 208 437 A1**

(12)

**EUROPEAN PATENT APPLICATION**

(43) Date of publication:  
**21.07.2010 Bulletin 2010/29**

(51) Int Cl.:  
**A47B 47/00 (2006.01)**

(21) Application number: **09150910.9**

(22) Date of filing: **20.01.2009**

(84) Designated Contracting States:  
**AT BE BG CH CY CZ DE DK EE ES FI FR GB GR HR HU IE IS IT LI LT LU LV MC MK MT NL NO PL PT RO SE SI SK TR**  
Designated Extension States:  
**AL BA RS**

(72) Inventor: **Li-Chung, Hsu**  
**Chiayi City 600 (TW)**

(74) Representative: **Lang, Christian et al**  
**LangRaible GbR**  
**Patent- und Rechtsanwälte**  
**Herzog-Wilhelm-Straße 22**  
**80331 München (DE)**

(71) Applicant: **Li-Chung, Hsu**  
**Chiayi City 600 (TW)**

(54) **Systemic cabinet**

(57) A systemic cabinet is composed of multiple boards 1 and multiple connecting pieces 4. Each board 1 has multiple mortises 11 defined at sides respectively to combine the corresponding connecting pieces 4 with supporting strength by wedging to perform configuration of the systemic cabinet. The connecting pieces 4 have

multiple types in design variation to provide orientation-positioning efficiency and have supporting strength to make the composed systemic cabinet firm and stable. Therefore, once one board 1 is worn out, only the worn board 1 is replaced by detaching the connecting pieces 4 to save other elements and to make the replacement easy and environmental for future repair.

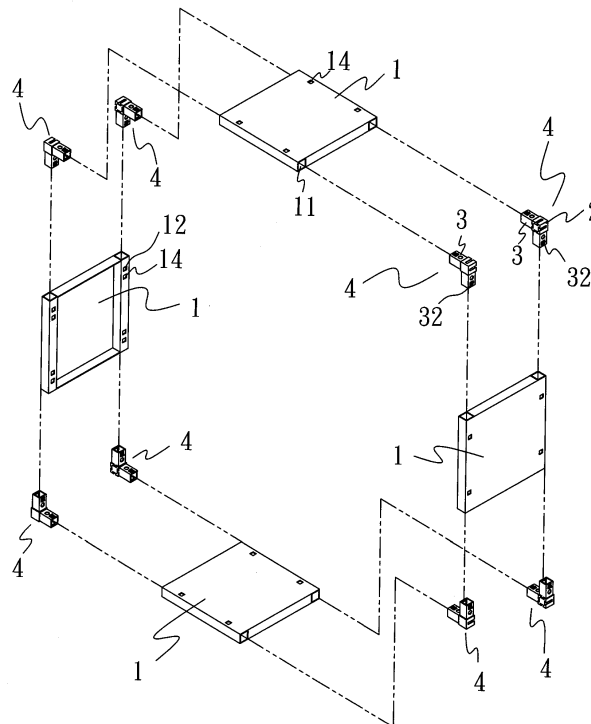

**FIG. 1**

**EP 2 208 437 A1**

**Description****BACKGROUND OF THE INVENTION**

## 1. Field of the Invention

**[0001]** The present invention relates to a systemic cabinet, and more particularly to a systemic cabinet composed of multiple assembling boards and corresponding connecting pieces having supporting strength so that this systemic cabinet enables to be assembled or disassembled rapidly and conveniently and has various embodiments according to different uses such as CD frames, grocery racks, closets, book shelves, or shoe cabinets etc.

## 2. Description of Related Art

**[0002]** In current market of systemic cabinet, manufacturers focus on design and process to increase the utility and transportation convenience of the conventional systemic cabinet. Therefore, the conventional systemic cabinets are mostly sold in assembling kits that have to be constructed by DIY and secured immovably by tools to perform the final frames or cabinets after consumers purchase them. Once the frames or the cabinets are worn too much to use, the whole systemic cabinets will be dumped directly because it is troublesome and time-consuming to disassemble the conventional systemic cabinets into pieces. Therefore, the wasted conventional systemic cabinets are not environmental friendly at all.

**SUMMARY OF THE INVENTION**

**[0003]** A main objective of the present invention is to provide a systemic cabinet that has multiple boards each having mortises defined at two opposite sides to make corresponding connecting pieces with supporting strength to engage for achieving combination. By assembling the multiple boards with the connecting pieces, the systemic cabinet is constructed quickly and conveniently by wedging in operation of combination. The connecting pieces have multiple types in design variation to provide different orientation-positioning efficiency and have supporting strength to make the composed systemic cabinet firm and stable. Therefore, once one board worn and needed to be replaced, only the worn board is changed by detaching the relative connecting pieces to save other elements and to make the replacement easy and environmental for future repair.

**[0004]** To achieve the foregoing objective, the systemic cabinet comprises multiple boards and multiple connecting pieces between adjacent two of the multiple boards, wherein the improvement of the systemic cabinet is that:

each of the multiple boards has multiple mortises defined at two opposite sides; and

each of the multiple connecting pieces has two ends inserting into two mortises on the adjacent two of the multiple boards respectively.

5 **[0005]** Further benefits and advantages of the present invention will become apparent after a careful reading of the detailed description with appropriate reference to the accompanying drawings.

10 **BRIEF DESCRIPTION OF THE DRAWINGS****[0006]**

15 Fig. 1 is an exploded perspective view of the first embodiment showing a unit component of the systemic cabinet in accordance with the present invention;

Figs. 2A and 2B are perspective views showing two different types of connecting pieces of the systemic cabinet in accordance with the present invention;

20 Fig. 3 is an exploded perspective view of the second embodiment of the systemic cabinet in accordance with the present invention;

25 Fig. 4 is an enlarged cross-sectional side view showing joints of the connecting pieces and relative boards of the systemic cabinet in Fig. 3;

30 Fig. 5 is an exploded perspective view of the third embodiment showing an enlarged unit component of the systemic cabinet in accordance with the present invention;

35 Fig. 6 is an exploded perspective view of the fourth embodiment of the enlarged unit component of the systemic cabinet in accordance with the present invention;

40 Fig. 7 is an enlarged cross-sectional side view showing joints of the connecting pieces and relative boards of the systemic cabinet in Fig. 6;

45 Fig. 8 is a perspective view of the third embodiment of the systemic cabinet in Fig. 5, wherein the enlarged unit component does not have front and rear boards;

50 Fig. 9 is an operational perspective view of the systemic cabinet in Fig. 8 to illustrate the attachment of the rear board;

55 Fig. 9A is an enlarged cross-sectional view showing joints between the rear board and a top board or a rear board;

Fig. 10 is a perspective view of the systemic cabinet in Fig. 9 to show the attachment of the front board;

Fig. 11 is an explode perspective view of the fifth embodiment of the systemic cabinet in Fig. 8 to combine with a drawer structure;

Fig. 12 is a perspective view of the systemic cabinet in Fig. 11;

Fig. 13 is a perspective view of the first embodiment of final configuration to show the systemic cabinet arranged in a ladder-shape;

Fig. 14 is a perspective view of the second embod-

iment of final configuration to show the systemic cabinet arranged in a T-shape;

Fig. 15 is a perspective view of the third embodiment of final configuration to show the systemic cabinet arranged in a R-shape;

Fig. 16 is a perspective view of the fourth embodiment of final configuration to show the systemic cabinet arranged in a J-shape;

Fig. 17 is a perspective view of the first embodiment of final configuration to show the systemic cabinet composed of multiple enlarged unit components arranged in a ladder shape;

Fig. 18 is a perspective view of a second embodiment of final configuration to show the systemic cabinet composed of multiple enlarged unit components with drawers arranged in vertical; and

Figs. 19-24 are perspective views of the third to seventh embodiments of final configurations of the systemic cabinets.

#### **DETAILED DESCRIPTION OF THE PREFERRED EMBODIMENT**

[0007] A systemic cabinet in accordance with the present invention is composed of multiple boards and multiple connecting pieces. Each board has multiple mortises defined at opposite sides respectively to combine the corresponding connecting pieces with supporting strength by wedging to perform compartments of the systemic cabinet. The connecting pieces have multiple variations in design to provide orientation-positioning efficiency and have supporting strength to make the composed systemic cabinet firm and stable. Therefore, once one board is worn out, only the worn board is replaced by detaching the connecting pieces to save other elements and to make the replacement easy and environmental for future repair.

[0008] As shown in Fig. 1, a single unit compartment of systemic cabinet comprises multiple boards 1 and multiple connecting pieces 4 at corners of the unit compartment.

[0009] Each board 1 is rectangular and has a predetermined width based on total configuration in design. Two opposite sides of the board 1 have four mortises 11 defined at ends and four locking holes 12 defined on one face of the board 1 to communicate with the mortises 11 respectively. Such boards 1 are uniform and defined as top boards, bottom boards, sideboards, bridging boards, erecting boards, adjacent boards and widened boards as applied to different orientation and modification mentioned below.

[0010] Each connecting piece 4 (as shown in Fig. 2A) has a locking body 2 and at least one tenon tube 3. The locking body 2 has multiple dovetail-grooves 21 defined on faces respectively to engage a dovetail-insertion 31 formed on the corresponding tenon tube 3. The dovetail-grooves 21 are not entirely transversal through the face of the locking body 2 to reserve a block section 22 (see

Fig. 2A) to keep the corresponding tenon tube 3 engaged at a limited position. Additionally, each tenon tube 3 has a protrusion 32 formed on a top face to align with the locking hole 12 on the board 1.

5 [0011] As shown in Fig. 2B, another type of the connecting piece 4' is that the tenon tube 3 and the locking body 2 are integrated into one-piece (Such a connecting piece 4' is embodied to apply to widened cabinet with widened boards). The connecting piece 4' has its length, the locking holes 33, and the protrusions 32 arranged and decided by supporting strength to the widened board 1.

10 [0012] With regard to assembly of the aforementioned multiple boards 1 and the multiple connecting pieces 4 (as shown in Fig. 1), the tenon tube 3 at one end of the connecting piece 4 inserts into the mortise 11 on one adjacent board 1 until the protrusion 32 on the tenon tube 3 engages the locking hole 12 on the board. By having the multiple connecting pieces 4 each composed of a locking body 2 and optional multiple tenon tubes 3, the boards 1 with predetermined sizes are combined and constructed to perform a unit component 5 (as shown Fig. 3, it is a narrow cabinet as an embodiment) easily and conveniently by wedging.

25 [0013] When the unit component 5 is to add more compartments (as shown in Figs. 3 and 4), four tenon tubes 3 are added to the unit component 5 and combined to the corresponding locking bodies 2 at corners respectively by engaging the dovetail-insertions 31 with the dovetail-grooves 21 snugly (as shown in Fig. 4). Moreover, each single tenon tube 3 inserts into the mortise 11 on corresponding one of two erecting sideboards 1 and is positioned by locking the protrusion 32 with the locking hole 12. Lastly, a bridging board 1 is mounted over the two erecting sideboards 1 by attaching four connecting pieces 4 at corners to perform the systemic cabinet with two components.

30 [0014] With regard to another embodiment of the systemic cabinet having enlarged size in assembly (as shown in Fig. 5), the connecting piece 4' in one-piece has two tenon tubes 3 arranged vertically to each other to insert into two mortises 11 of two adjacent boards 1 respectively until the protrusions 32 engage the locking holes 12. Four boards 1 are arranged one by one in loop and eight connecting pieces 4' fix the corners for four boards 1 by above-mentioned ways to compose one compartment. Because the locking body 2 and the two tenon tubes 3 of the connecting piece 4' are in one piece, the connecting piece 4' provides sufficient supporting strength to the widened boards 1 which are widened. By constructing and positioning the widened boards 1 with the one-pieced connecting pieces 4', the unit component 5' having one compartment is achieved (as shown in Fig. 6).

45 [0015] When the unit component 5' is to add more compartments (as shown in Figs. 6 and 7), the unit component 5' adds four tenon tubes 3 combined to the corresponding locking bodies 2 at corners respectively by engaging the

dovetail-insertions 31 with the dovetail-grooves 21 snugly (as shown in Fig. 7). Moreover, each single tenon tube 3 inserts into the mortise 11 on corresponding one of two erecting sideboards 1 and is positioned by locking the protrusion 32 with the locking hole 12. Lastly, a bridging board 1 is mounted over the two erecting sideboards 1 by attaching four connecting pieces 4' at corners to perform the systemic cabinet having two components.

**[0016]** The aforementioned unit compartment 5' is uncovered at front and rear sides (as shown in Fig. 8) and is selectively mounted with a rear board 51 (as shown in Fig. 9). The rear board 51 has positioning protrusions 511, 512 wedging into corresponding through holes 14 defined on the top and bottom boards 1 for positioning (as shown in Figs. 9 and 9A), wherein two of the positioning protrusions 512 at bottom are rectangular stubs and two of the positioning protrusions 511 at top are arc-shaped to make the rear board 51 easily pushed into space between the top and bottom boards 1. Moreover, the unit component 5' enables to be pivotally mounted with a front board 52 by hinges (as shown in Fig. 10, not numbered). Depending on the use of the unit component 5', a drawer 53 is accommodated inside (as shown in Fig. 12) and is composed of a U-shaped case 531 with a front plate 533 and a rear plate 532 combined into one-piece (as shown in Fig. 11) so that the combined drawer 53 is movably accommodated in the unit component 5'.

**[0017]** The aforementioned unit components 5 enable to be modified to different arrangements such as a ladder-shape configuration 10 (as shown in Fig. 13), a T-shape configuration 20 (as shown in Fig. 14), a R-shape configuration 30 (as shown in Fig. 15), and a J-shape configuration 40 (as shown in Fig. 16) for creating fun in decoration. With regard to unit components 5' with widened size enable to be modified to different arrangements such as a ladder-shape configuration 50 (as shown in Fig. 17), multiple file cabinet configurations 60, 70 and 80 (as shown in Figs. 18-20), a closet configuration 90 (as shown in Fig. 21), a staked configuration 100 for which each compartment has cover boards 1001 at front and rear faces (as shown in Figs. 22 and 23), and a staked configuration 110 having compartments with different sizes for creating more utility in use (as shown Fig 24).

**[0018]** The aforementioned systemic cabinet has the following advantages in assembly and practice:

1. By composing multiple boards with multiple connecting pieces to perform the predetermined cabinet, the assembling operation is quick and convenient and the combined cabinet is stable and firm.
2. Once the systemic cabinet is worn out too much to use, only the broken parts of systemic cabinet can be replaced by detaching the relative connecting pieces easily for material saving. Otherwise, the whole systemic cabinet can be disassembled into pieces to reduce occupied space during recycling process for environmental protection.

3. The unit components for the systemic cabinet are variable to extend and create more embodiments both for utility purpose and for decorative purpose.

## Claims

1. A systemic cabinet comprising multiple boards 1 and multiple connecting pieces 4 between adjacent two of the multiple boards 1, wherein the improvement of the systemic cabinet is that:

each of the multiple boards 1 has multiple mortises 11 defined at two opposite sides; and each of the multiple connecting pieces 4 has two ends respectively inserting into two mortises 11 on the adjacent two of the multiple boards 1.

2. The systemic cabinet as claimed in claim 1, wherein each of the multiple connecting pieces 4 has:

a locking body 2 having at least two dovetail-grooves 21 defined at sides respectively without transversally grooving to reserve a block section 22; and a tenon tube 3 having a dovetail-insertion 31 to engage corresponding one of the at least two dovetail-grooves 21 to connect to each adjacent board 1.

3. The systemic cabinet as claimed in claim 1, wherein each of the multiple connecting pieces 4' has:

a locking body 2 having at least two dovetail-grooves 21 defined at sides respectively without transversal grooving to reserve a block section 22; and two tenon tubes 3 integrally formed on the locking body 2 to respectively connect to the adjacent two of the multiple boards 1.

4. The systemic cabinet as claimed in claim 3, wherein the connecting piece 4' further comprises:

a single tenon tube 3 having a dovetail-insertion 31 to engage corresponding one of the at least two dovetail-grooves 21 to connect to each adjacent board.

5. The systemic cabinet as claimed in claim 3, wherein each of the multiple boards 1 further has a locking hole 12 defined on the board 1 to communicate with each of the multiple mortises 11; and each of the two tenon tubes 3 has a protrusion 32 snugly engaging the locking hole 12 on the board 1.

6. The systemic cabinet as claimed in claim 5 further comprising a rear board with multiple positioning pro-

trusions 511, 512 at top sides and bottom sides respectively; and each of the multiple boards 1 further has multiple through hole 14 defined on the board 1 to engage with the positioning protrusions 511, 512 respectively.

10

15

20

25

30

35

40

45

50

55

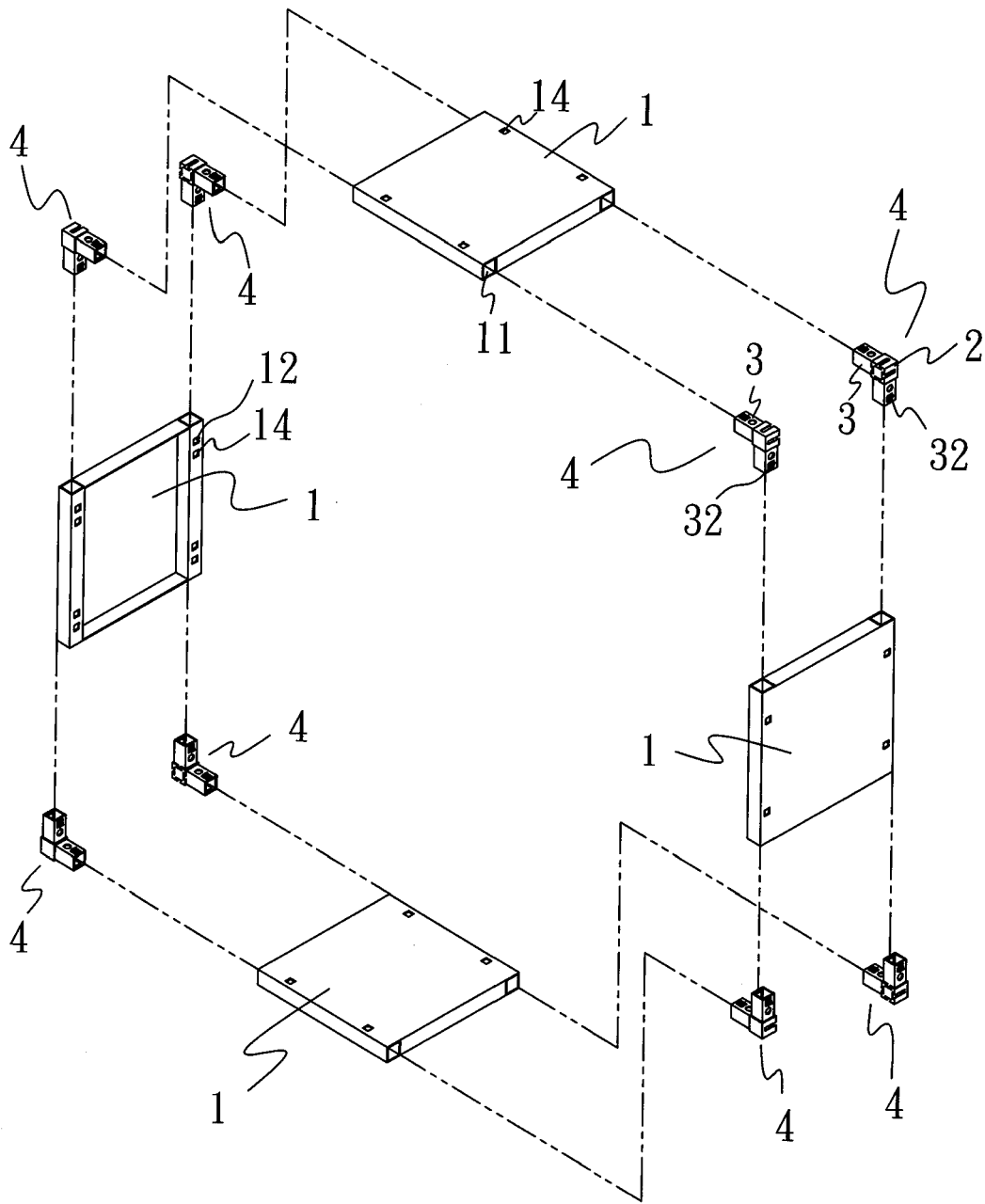

FIG. 1

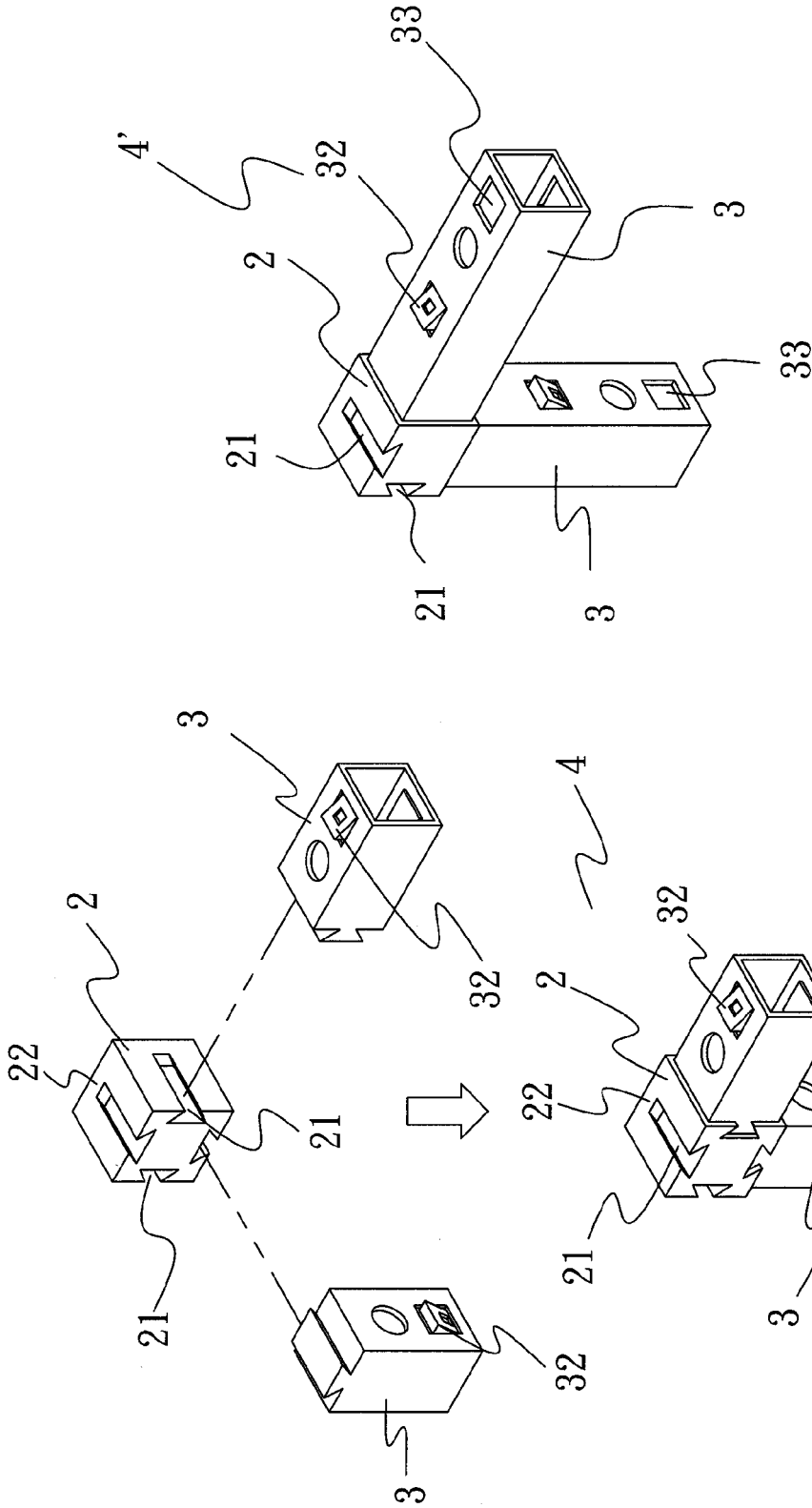

FIG. 2B

FIG. 2A

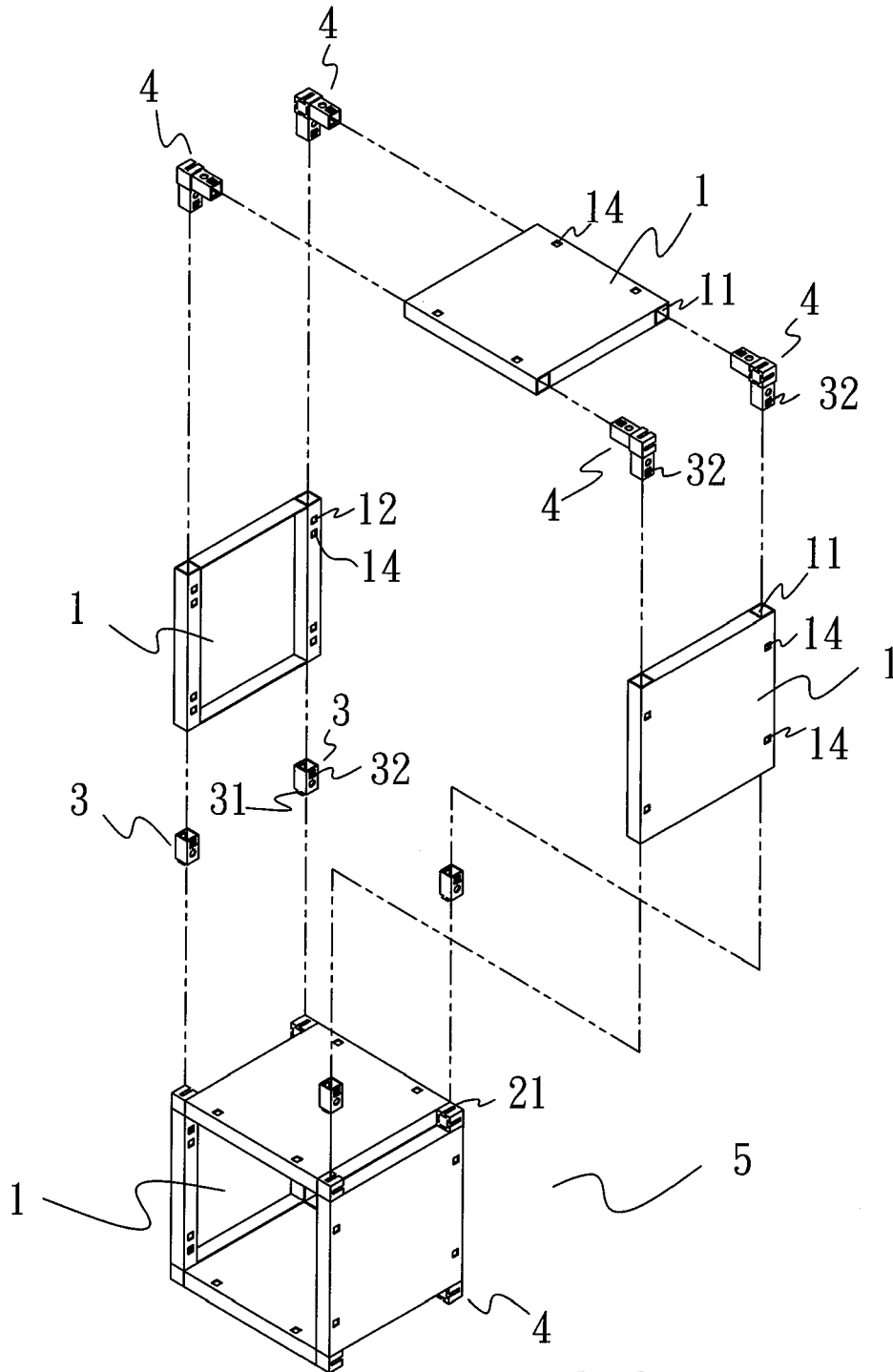

FIG. 3





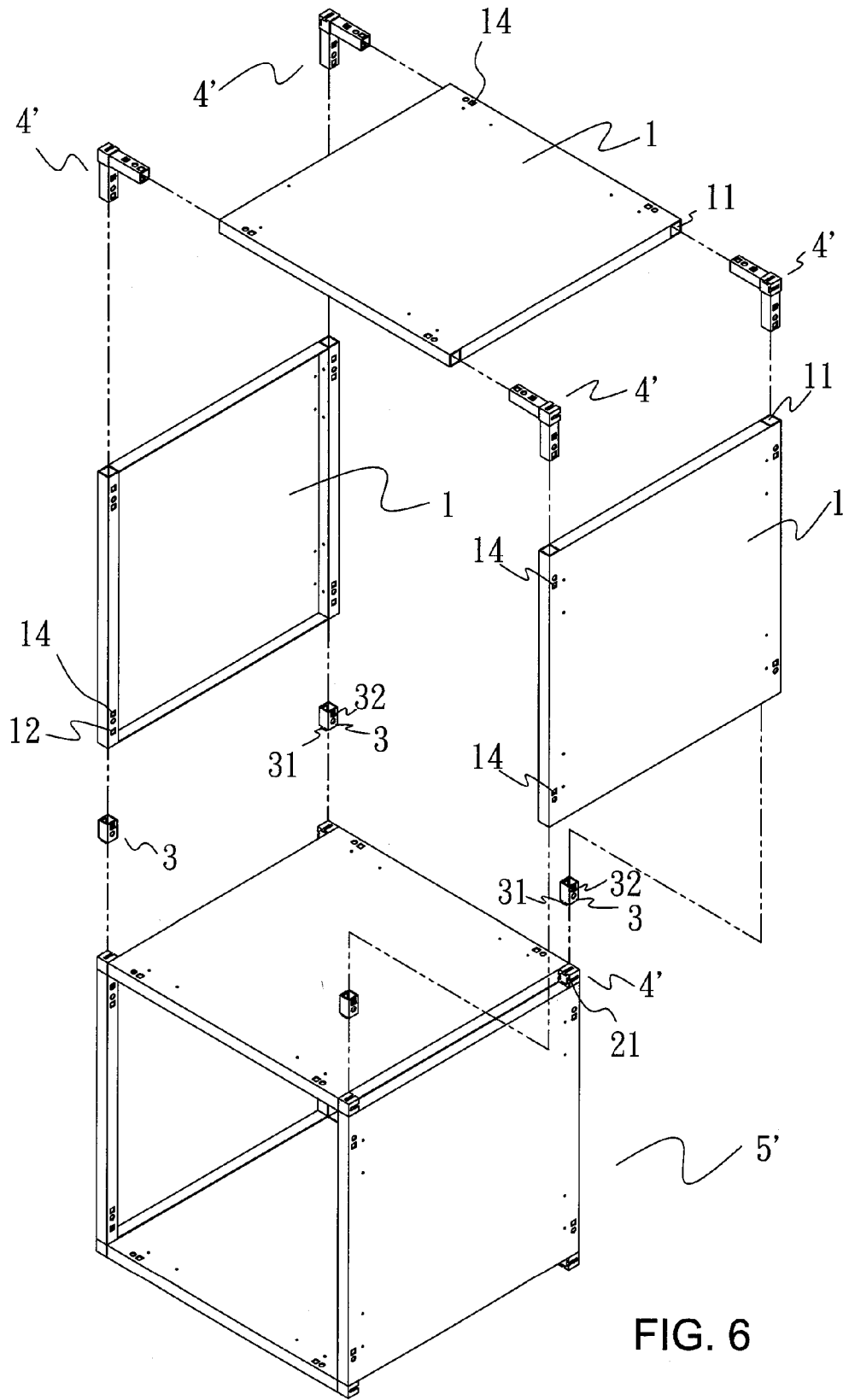

FIG. 6

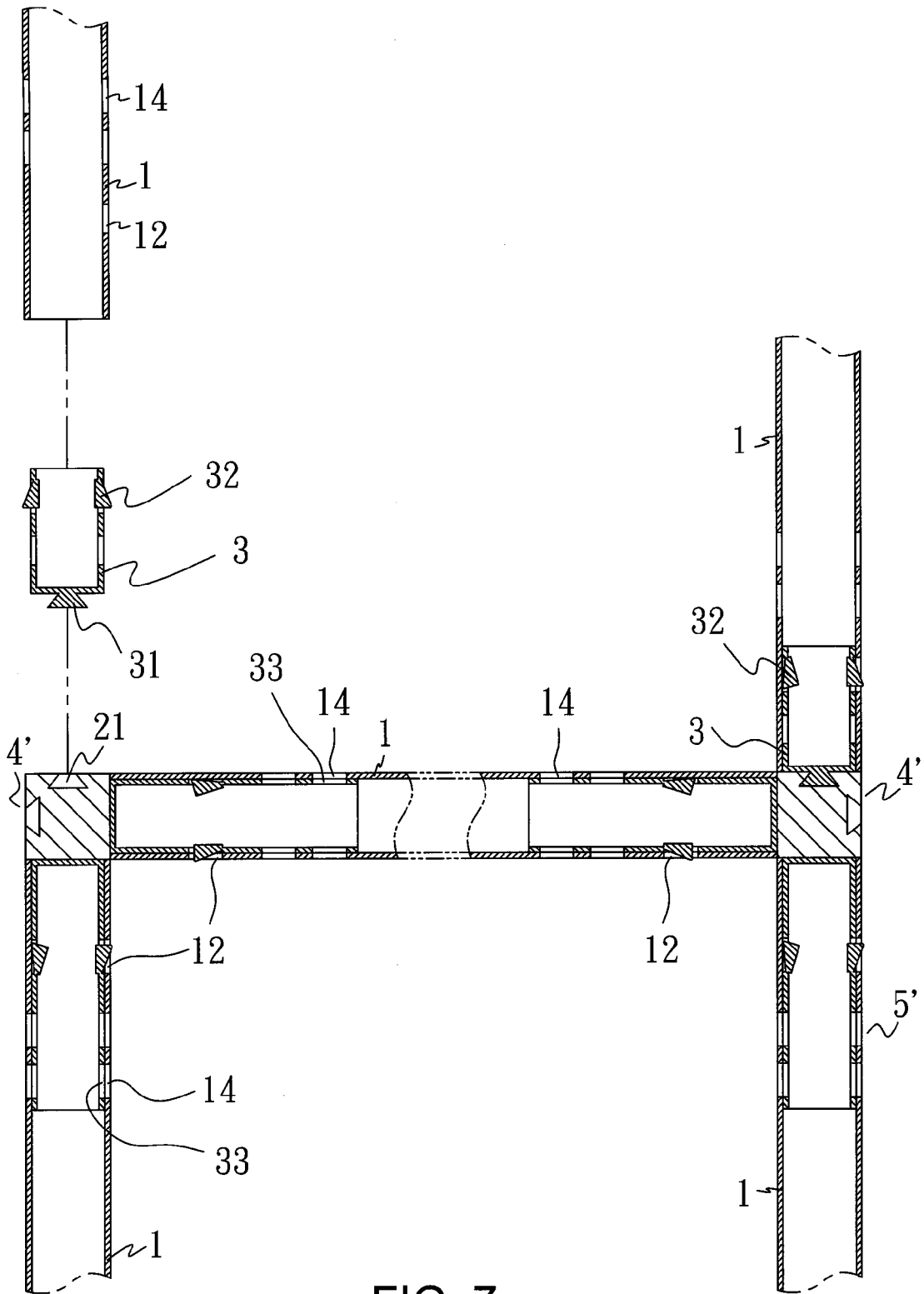

FIG. 7

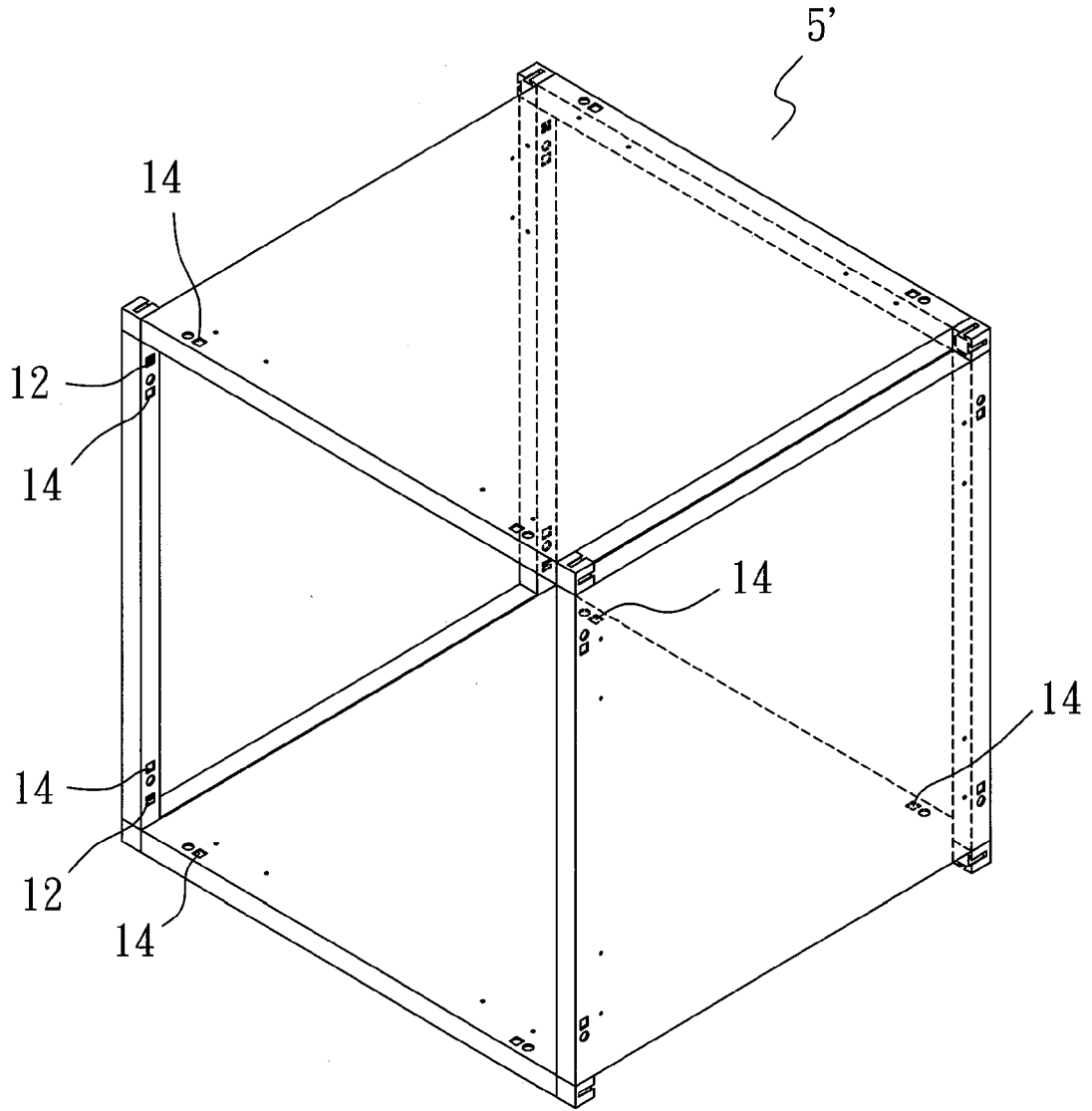

FIG. 8

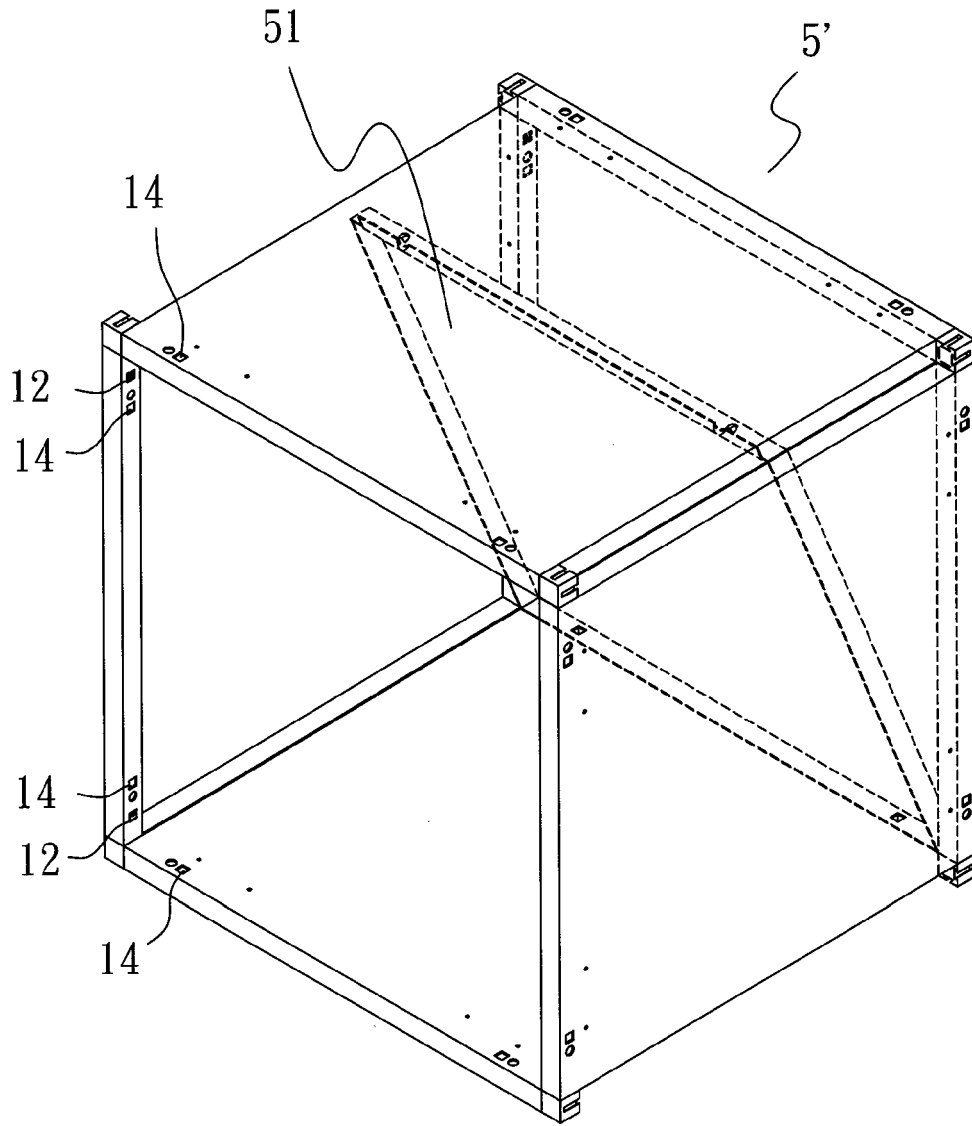

FIG. 9

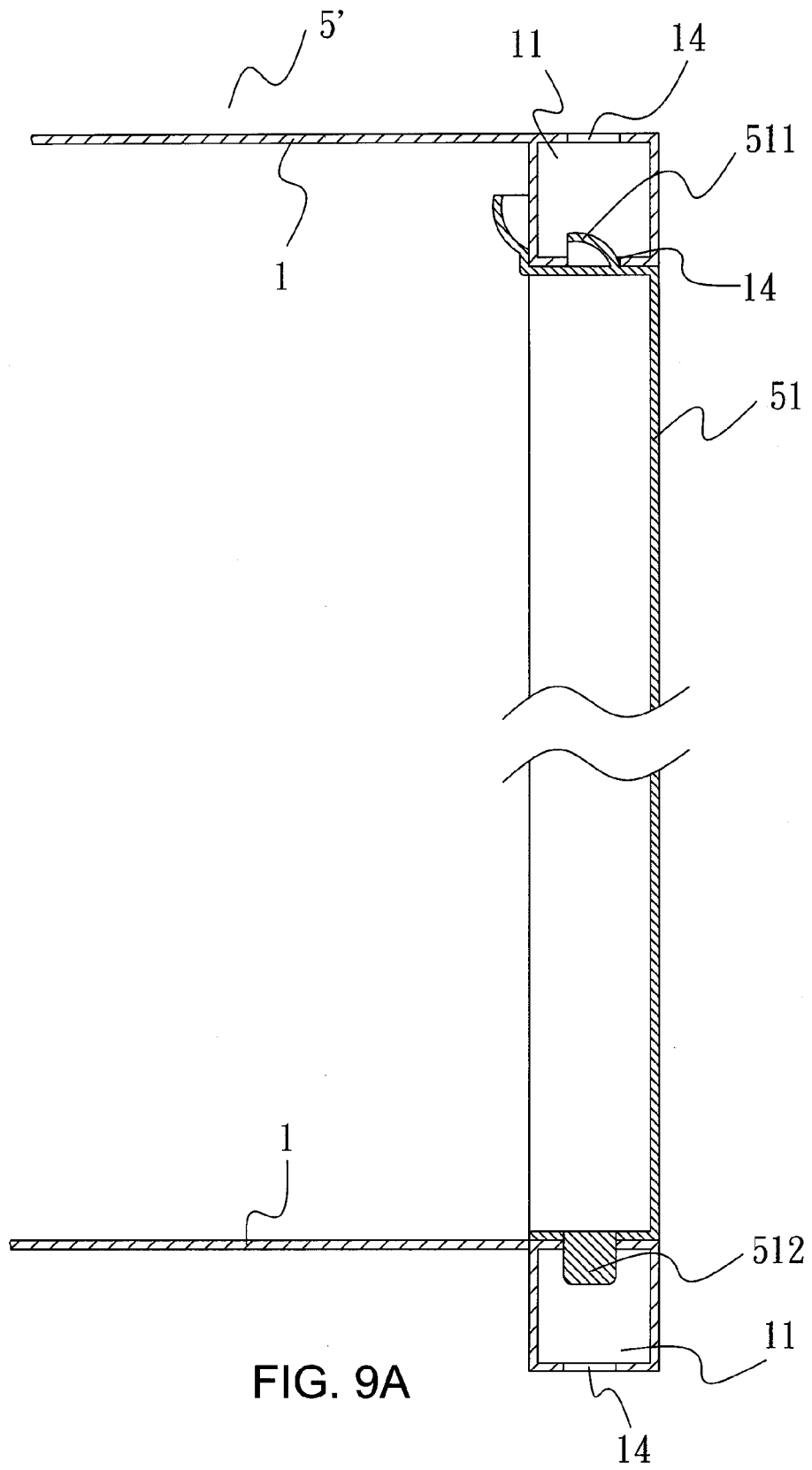

FIG. 9A

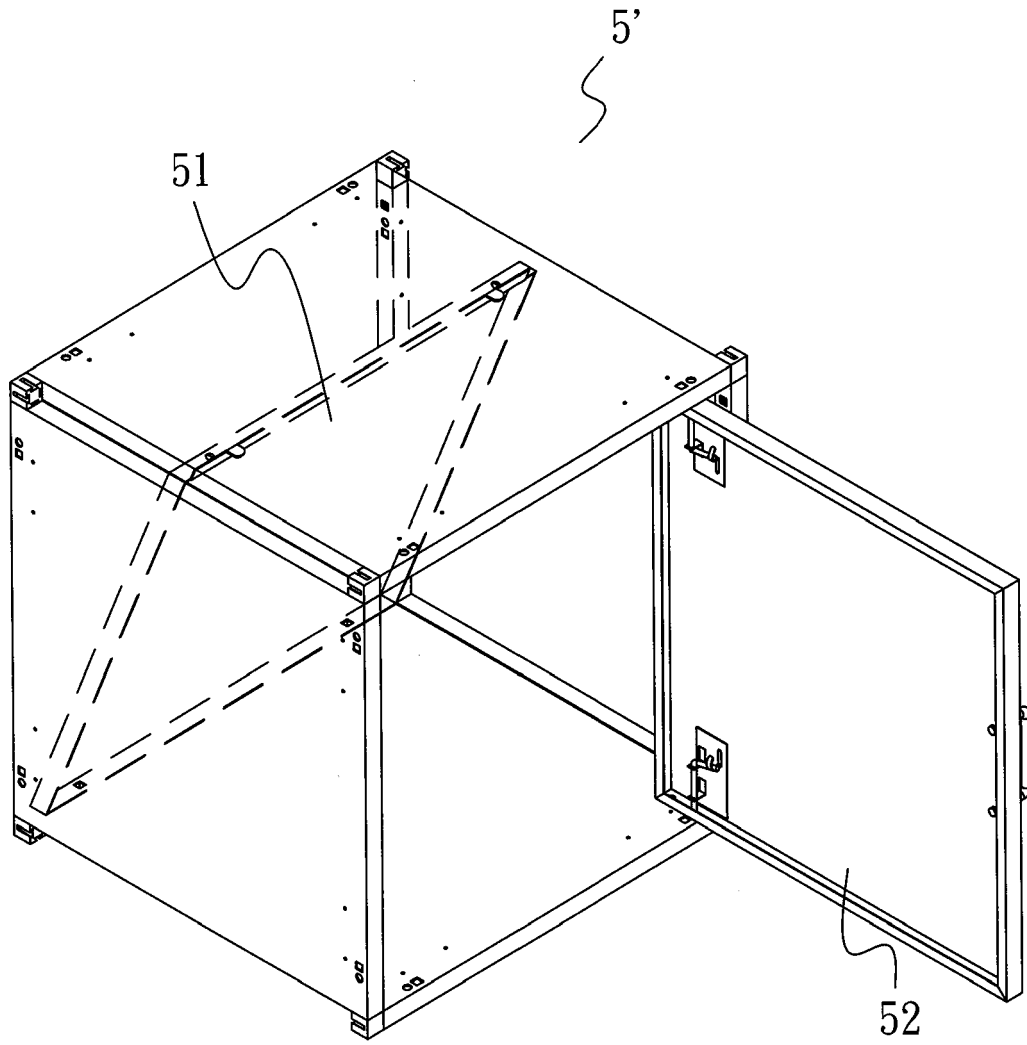

FIG. 10

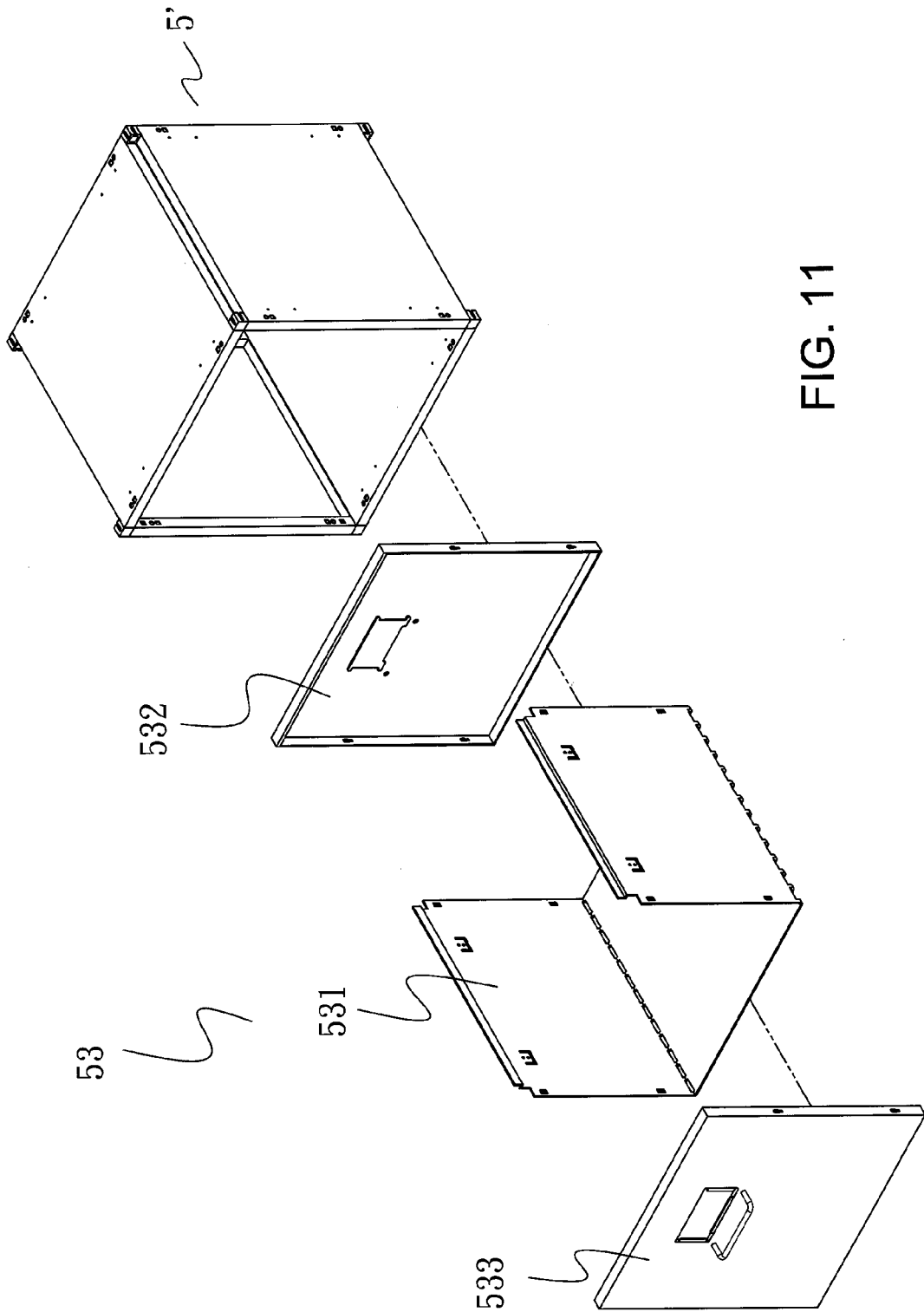

FIG. 11

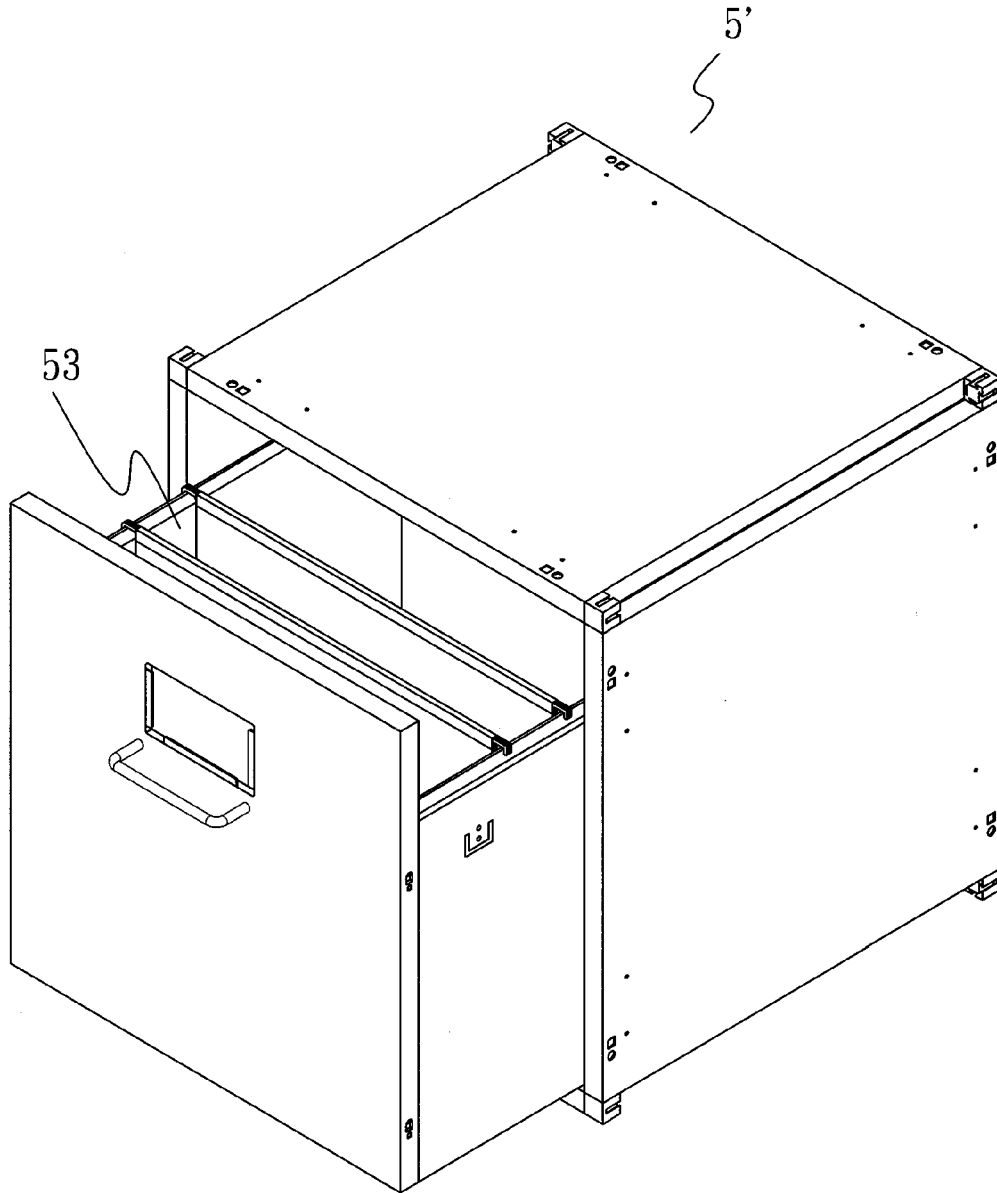

FIG. 12

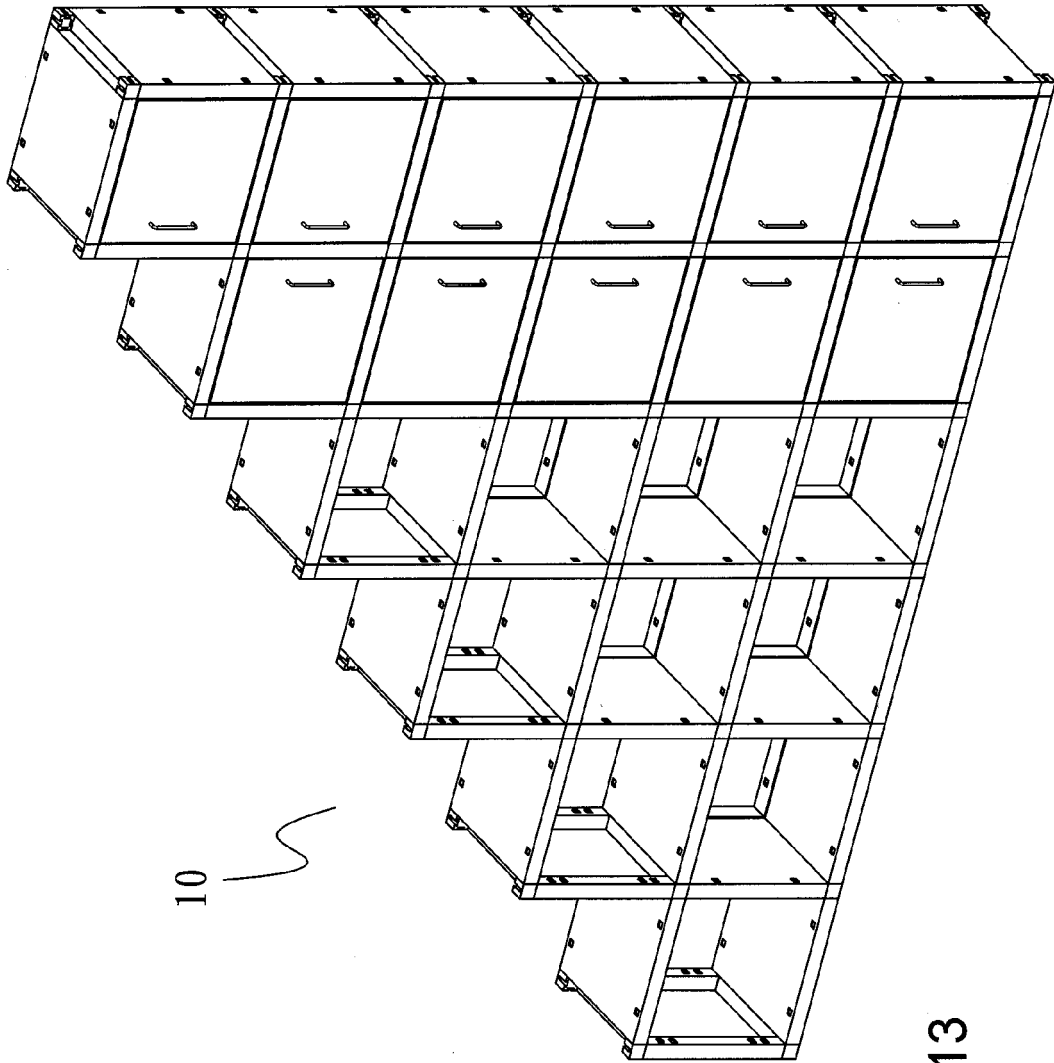

FIG. 13

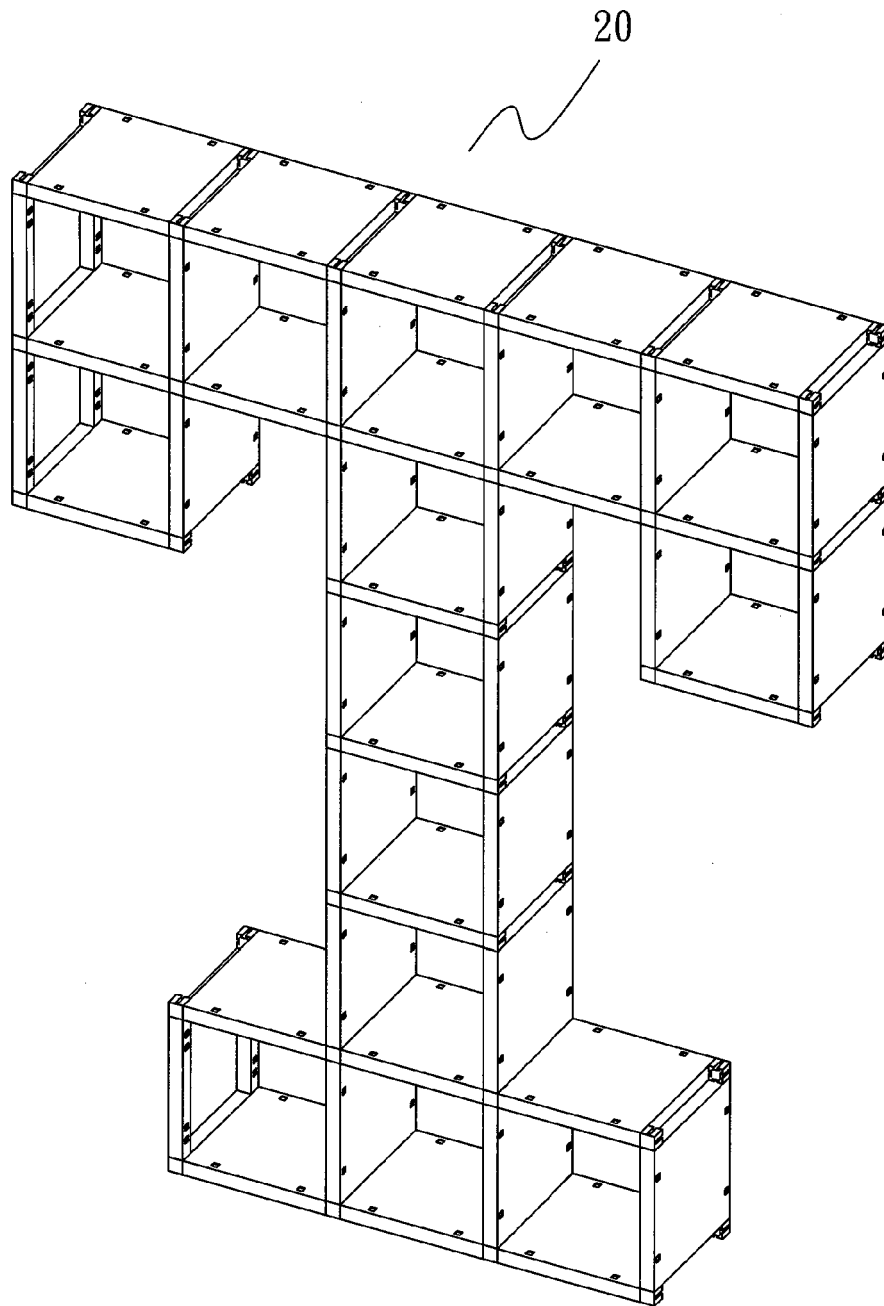

FIG. 14

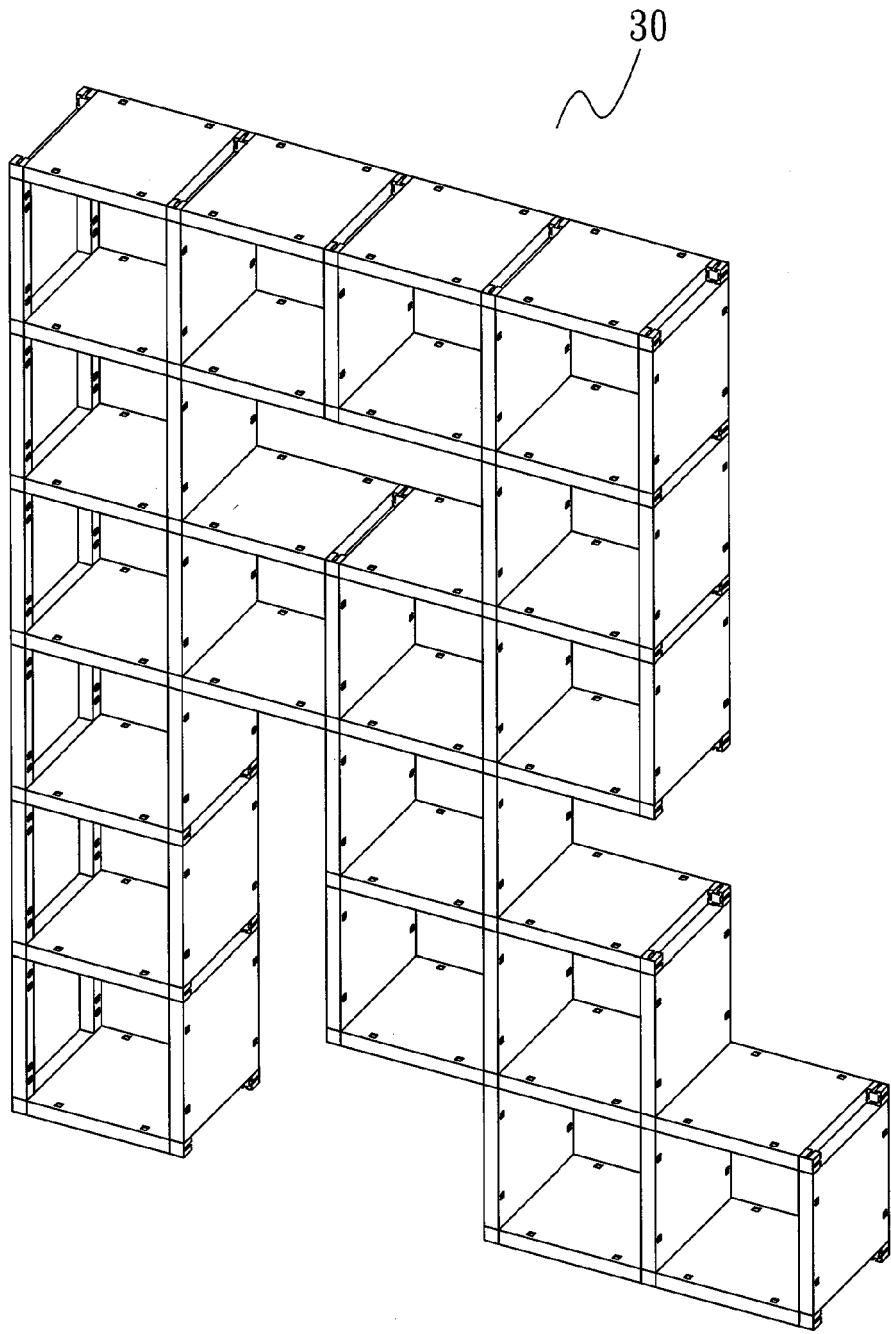

FIG. 15

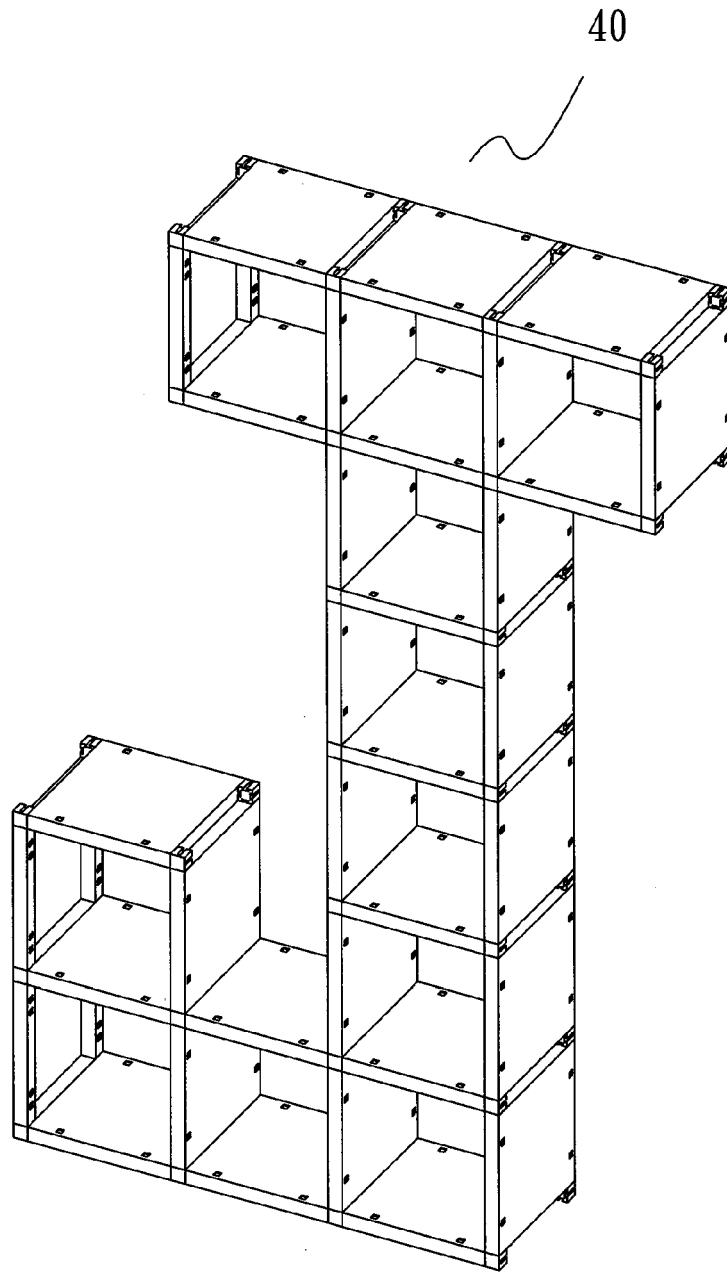

FIG. 16

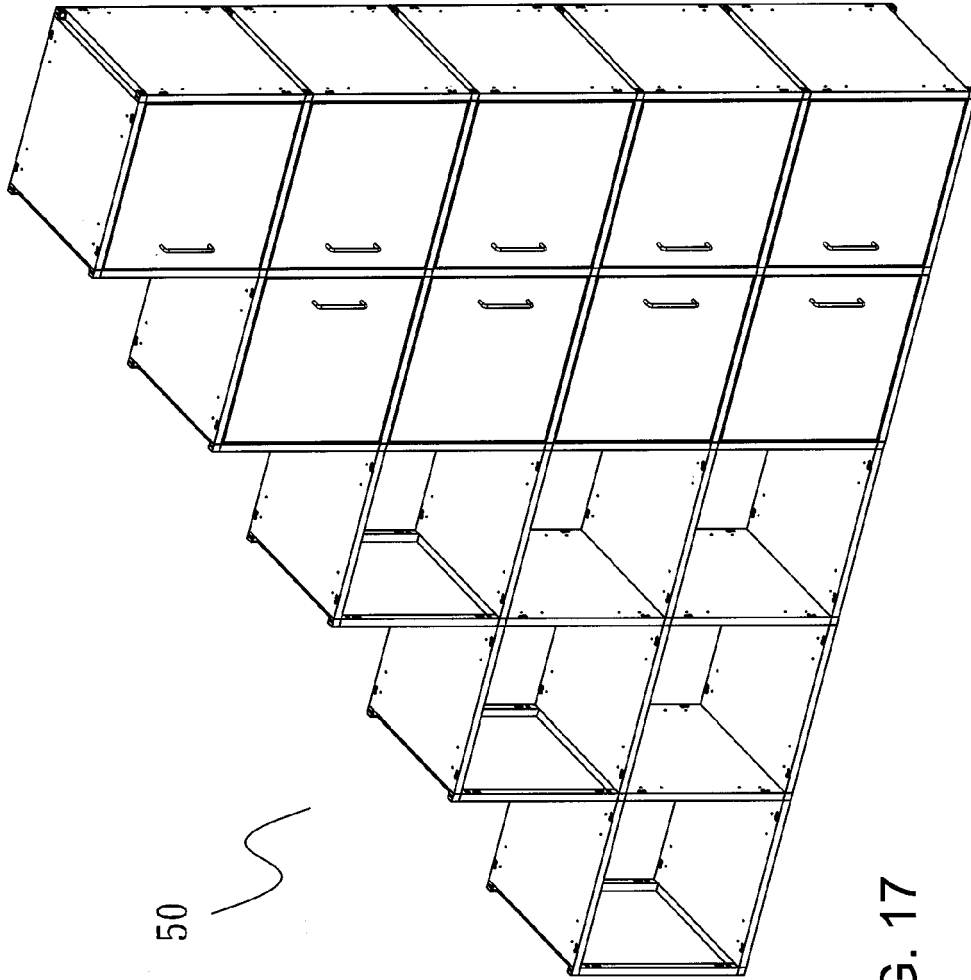

FIG. 17

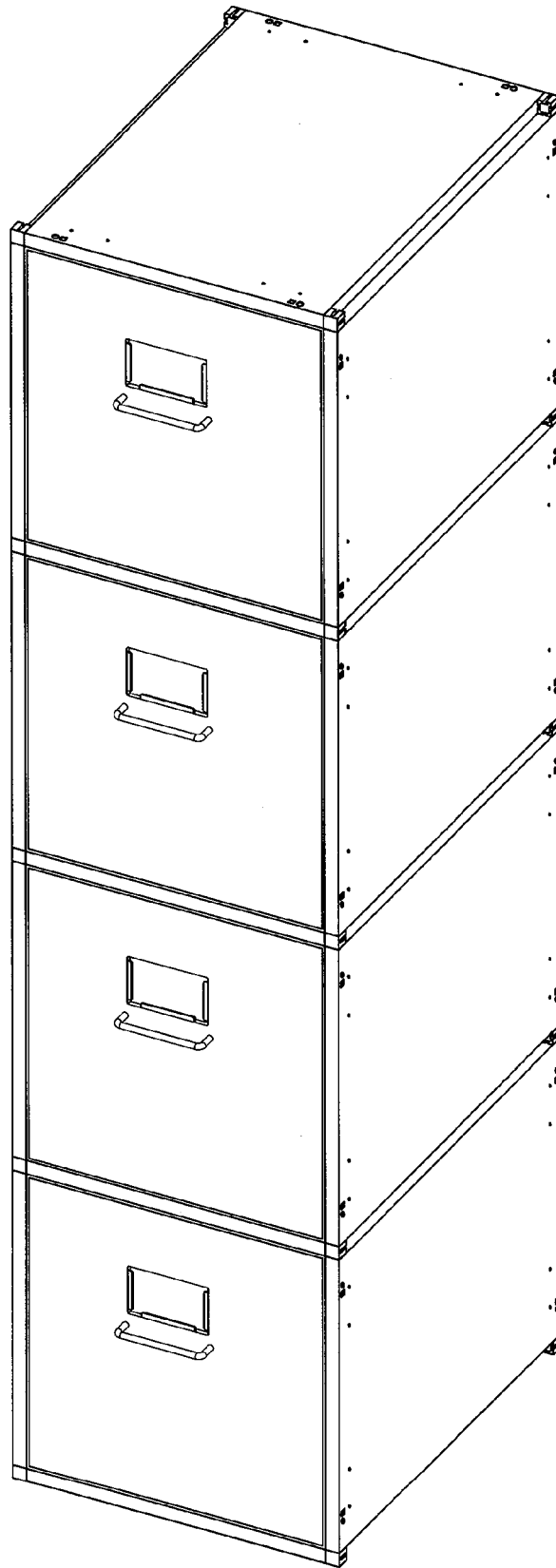

FIG. 18

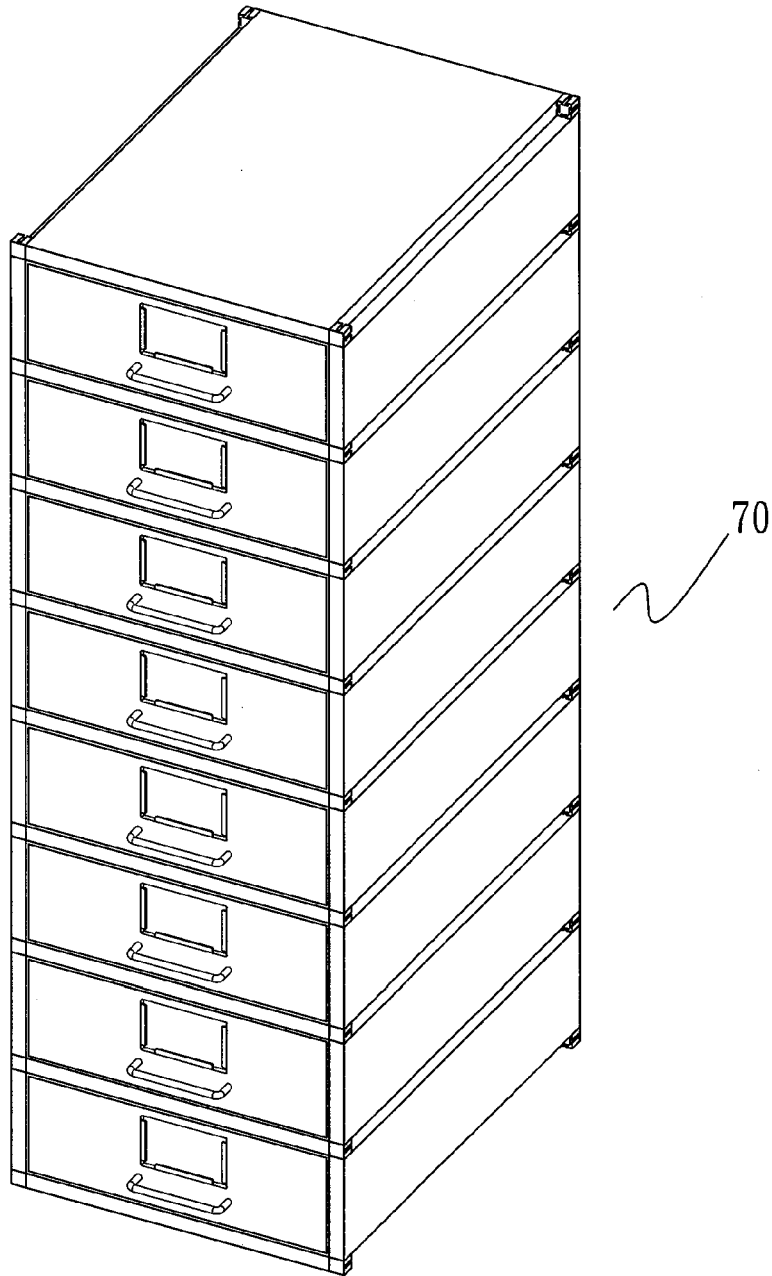

FIG. 19

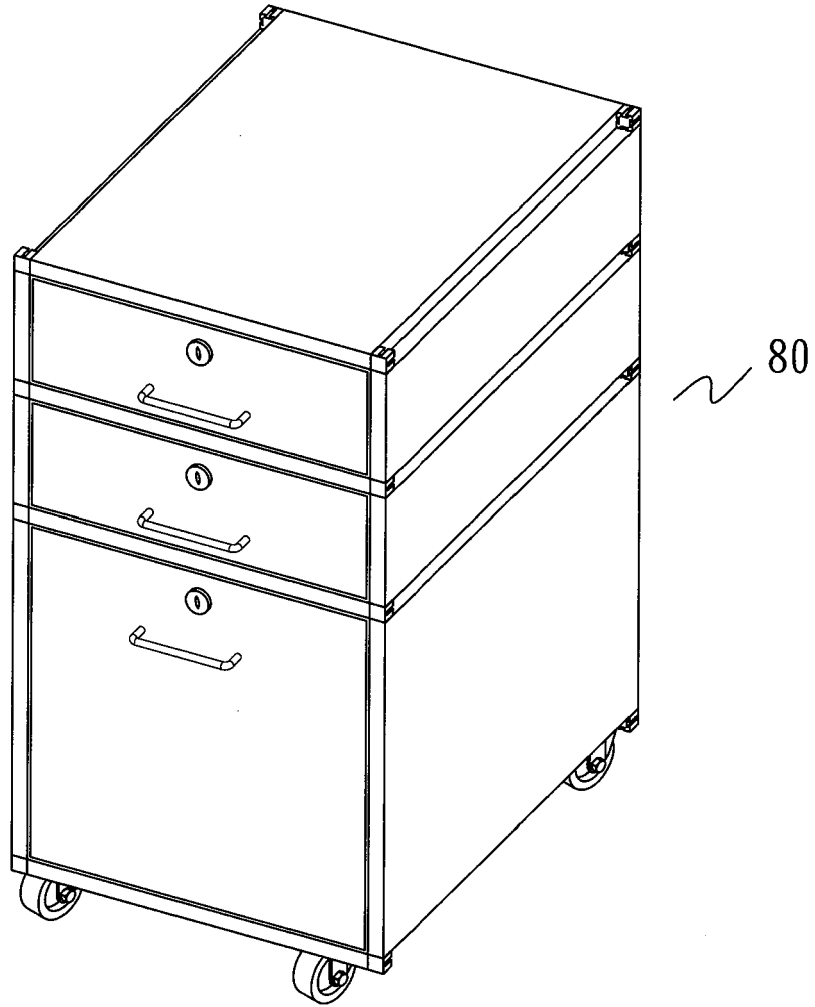

FIG. 20

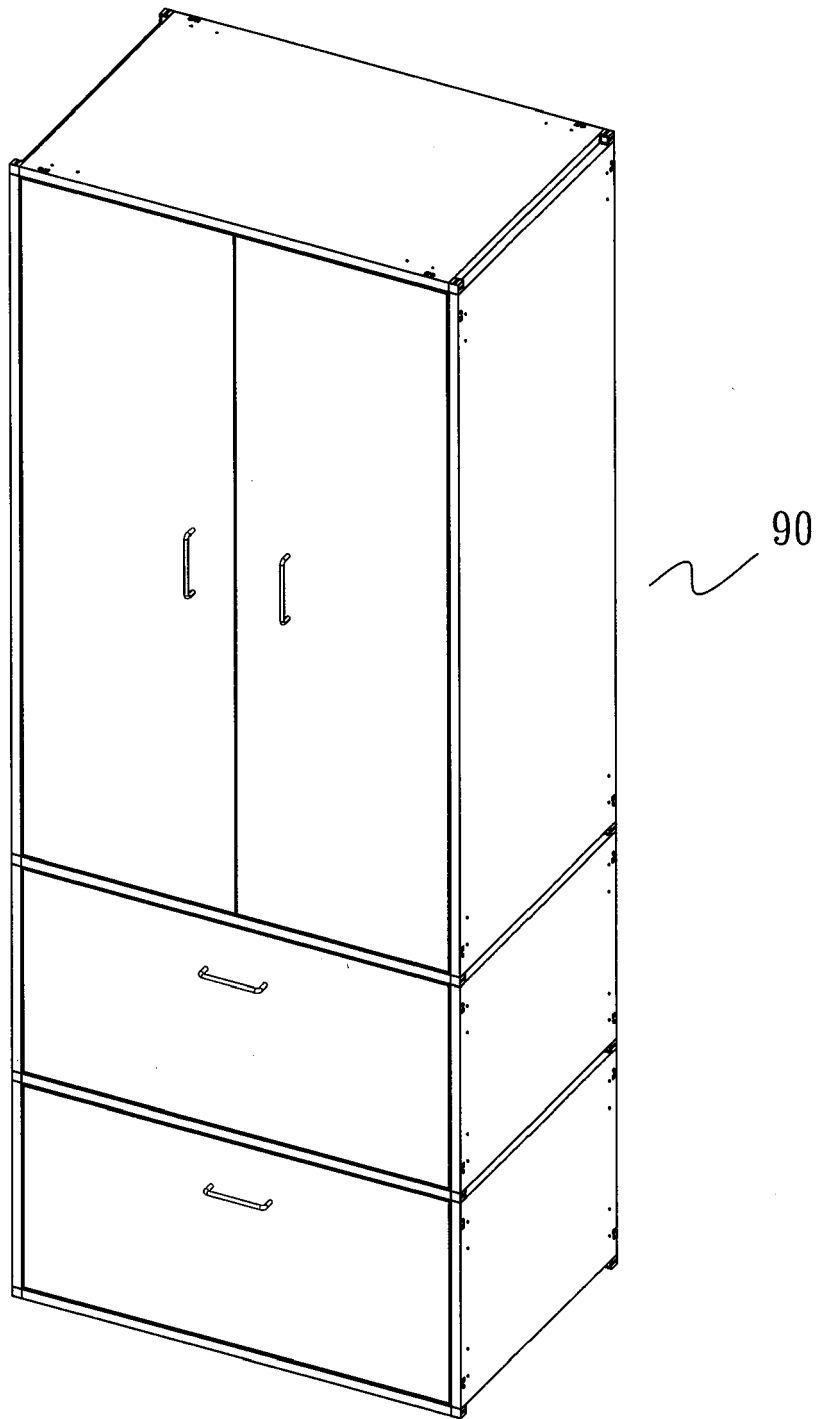

FIG. 21

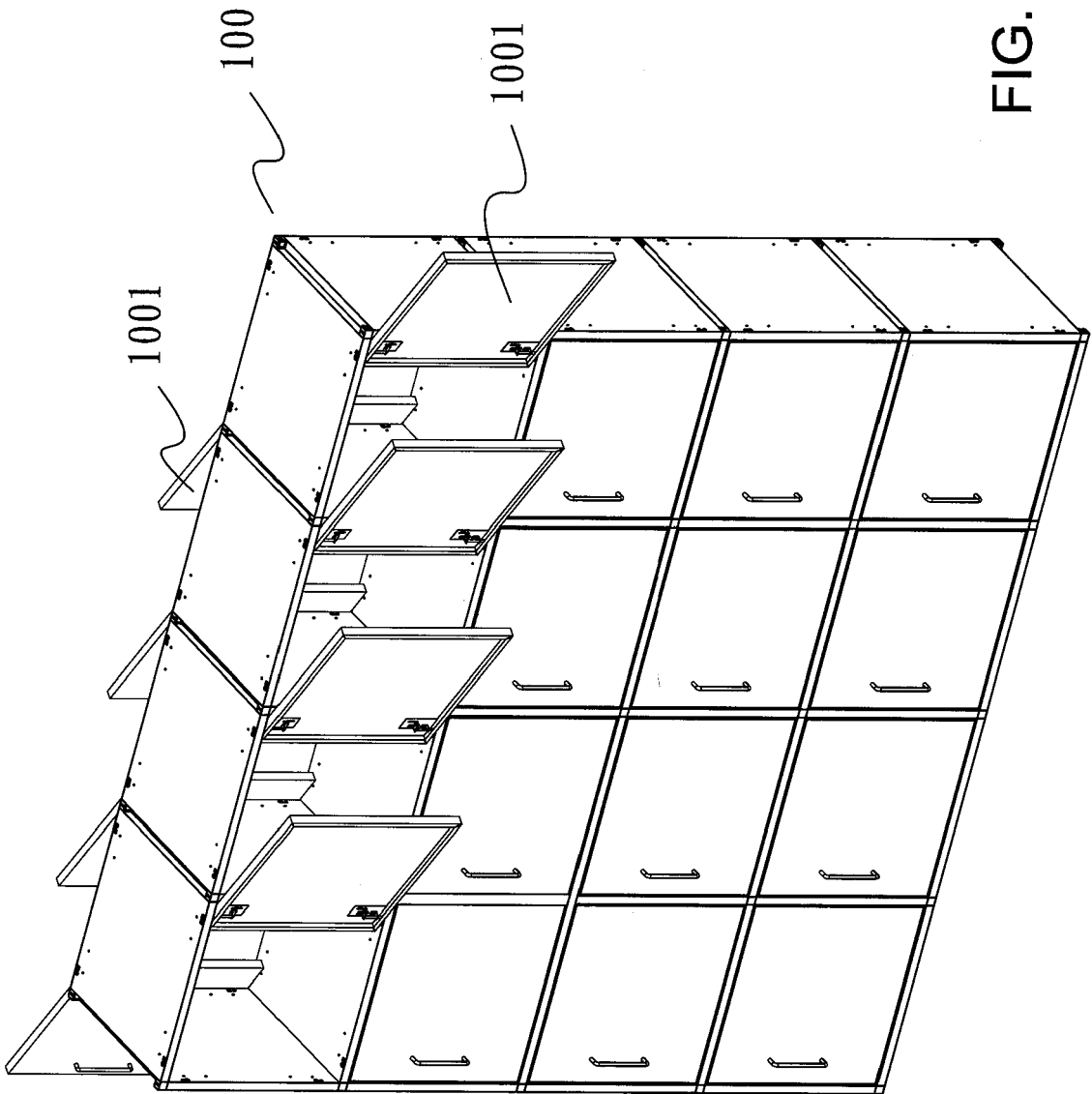

FIG. 22

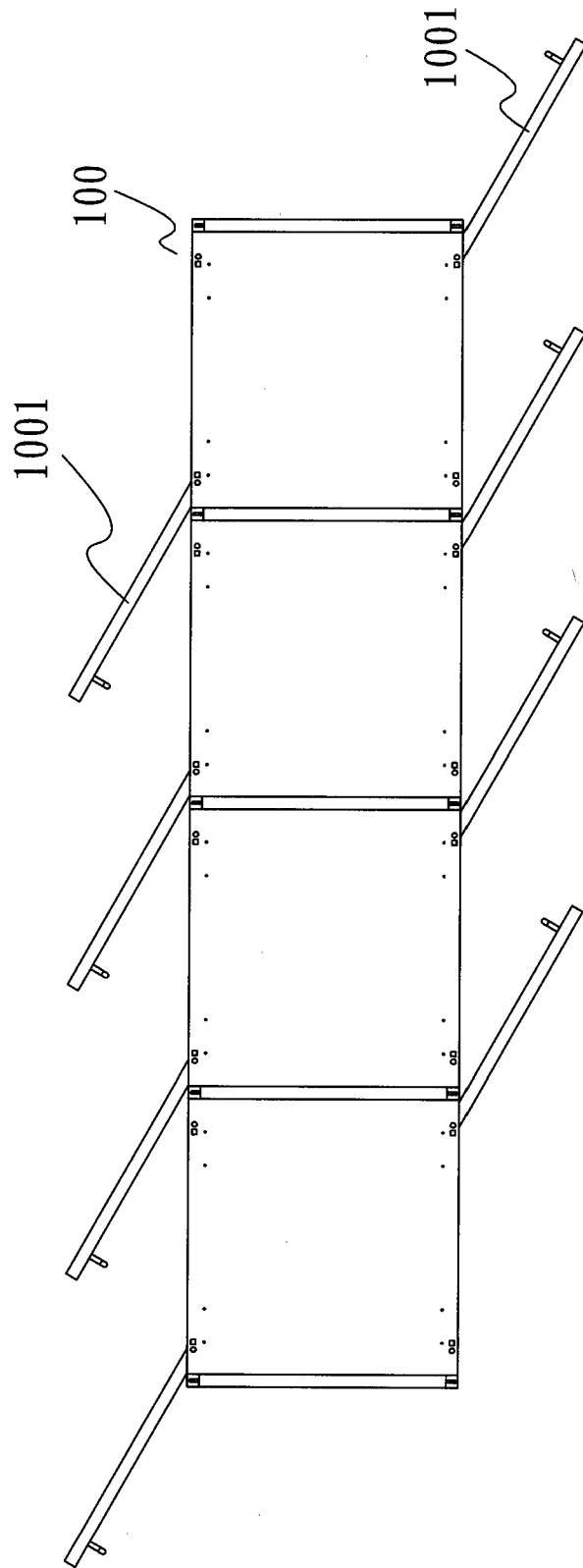

FIG. 23

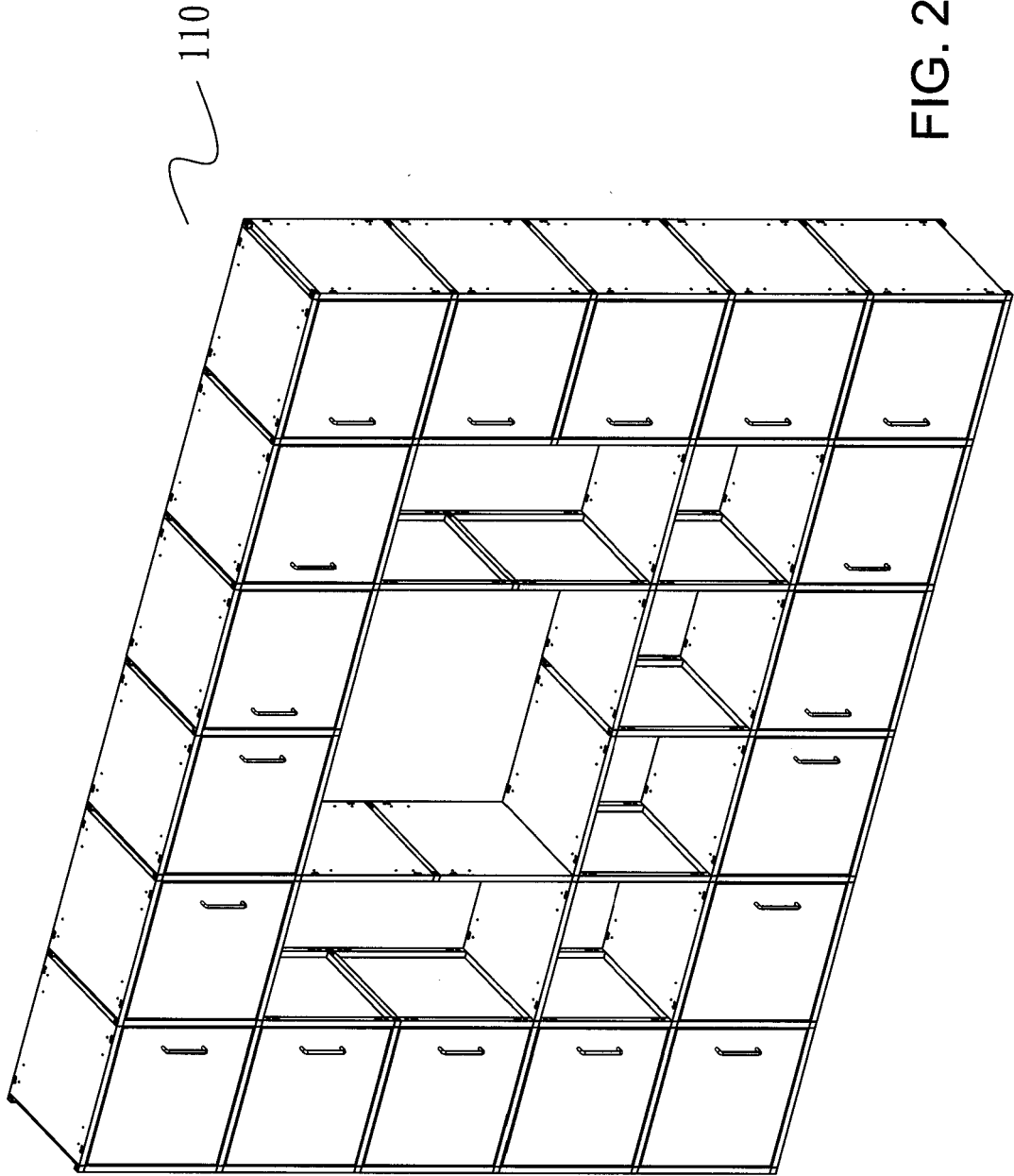

FIG. 24



EUROPEAN SEARCH REPORT

Application Number  
EP 09 15 0910

DOCUMENTS CONSIDERED TO BE RELEVANT			
Category	Citation of document with indication, where appropriate, of relevant passages	Relevant to claim	CLASSIFICATION OF THE APPLICATION (IPC)
X	US 5 590 974 A (YANG TIAN-SHOW) 7 January 1997 (1997-01-07) * the whole document * -----	1,5	INV. A47B47/00
X	US 2007/132345 A1 (LAI CHUN-YI) 14 June 2007 (2007-06-14) * figure 2 * -----	1,6	
X	US 2004/222722 A1 (YANG SHAOBIN) 11 November 2004 (2004-11-11) * figure 7 * -----	1	
X	US 7 014 267 B1 (NAGAR NIR) 21 March 2006 (2006-03-21) * the whole document * -----	1	
The present search report has been drawn up for all claims			TECHNICAL FIELDS SEARCHED (IPC)
			A47B
1	Place of search Munich	Date of completion of the search 4 August 2009	Examiner Reichhardt, Otto
CATEGORY OF CITED DOCUMENTS		T : theory or principle underlying the invention E : earlier patent document, but published on, or after the filing date D : document cited in the application L : document cited for other reasons ..... & : member of the same patent family, corresponding document	
X : particularly relevant if taken alone Y : particularly relevant if combined with another document of the same category A : technological background O : non-written disclosure P : intermediate document			

EPO FORM 1503 03/02 (P04/C01)

**ANNEX TO THE EUROPEAN SEARCH REPORT  
ON EUROPEAN PATENT APPLICATION NO.**

EP 09 15 0910

This annex lists the patent family members relating to the patent documents cited in the above-mentioned European search report. The members are as contained in the European Patent Office EDP file on  
The European Patent Office is in no way liable for these particulars which are merely given for the purpose of information.

04-08-2009

Patent document cited in search report		Publication date	Patent family member(s)	Publication date
US 5590974	A	07-01-1997	NONE	
US 2007132345	A1	14-06-2007	TW 290698 Y	21-05-2006
US 2004222722	A1	11-11-2004	WO 03013308 A1 CN 2492701 Y JP 2004537017 T	20-02-2003 22-05-2002 09-12-2004
US 7014267	B1	21-03-2006	NONE	

EPO FORM P0459

For more details about this annex : see Official Journal of the European Patent Office, No. 12/82