



(11) **EP 2 221 418 A1**

(12) **EUROPEAN PATENT APPLICATION**

(43) Date of publication:
25.08.2010 Bulletin 2010/34

(51) Int Cl.:
E02D 7/24 (2006.01) E02D 7/26 (2006.01)

(21) Application number: **10153248.9**

(22) Date of filing: **11.02.2010**

(84) Designated Contracting States:
AT BE BG CH CY CZ DE DK EE ES FI FR GB GR HR HU IE IS IT LI LT LU LV MC MK MT NL NO PL PT RO SE SI SK SM TR

(72) Inventors:
• **van de Coterlet, Johannes Gerardus**
3752 CW, Bunschoten (NL)
• **van der Heide, Nicolaas**
9218 P, Opeinde (NL)

(30) Priority: **18.02.2009 NL 2002543**

(74) Representative: **Ketelaars, Maarten F.J.M.**
Nederlandsch Octrooibureau
J.W. Frisolaan 13
2517 JS Den Haag (NL)

(71) Applicant: **Sterk Midden Nederland B.V.**
3755 LD Eembrugge (NL)

(54) **Method and device for driving a series of sheet pile planks into the ground**

(57) A device for carrying out the method for driving a series (1) of sheet pile planks (4) into the ground comprises individual drive-in means (8) for individually acting on at least two sheet pile planks (4), and pressure means (11,12,13) for supplying fluid to the individual sheet pile planks at excess pressure. The pressure means are designed for optionally dispensing fluid (19) either at a relatively high pressure and/or a relatively high flow rate, on the one hand, or fluid (18) at a relatively low pressure and/or a relatively low flow rate, on the other hand. Control means are provided for activating the drive-in means (8) associated with a sheet pile plank, for simultaneously supplying the fluid (19) at a relatively high pressure and/or a relatively high flow rate to said sheet pile plank and simultaneously supplying the fluid (18) at a relatively low pressure and/or a relatively low flow rate to the sheet pile plank which is kept stationary.

Fig 3

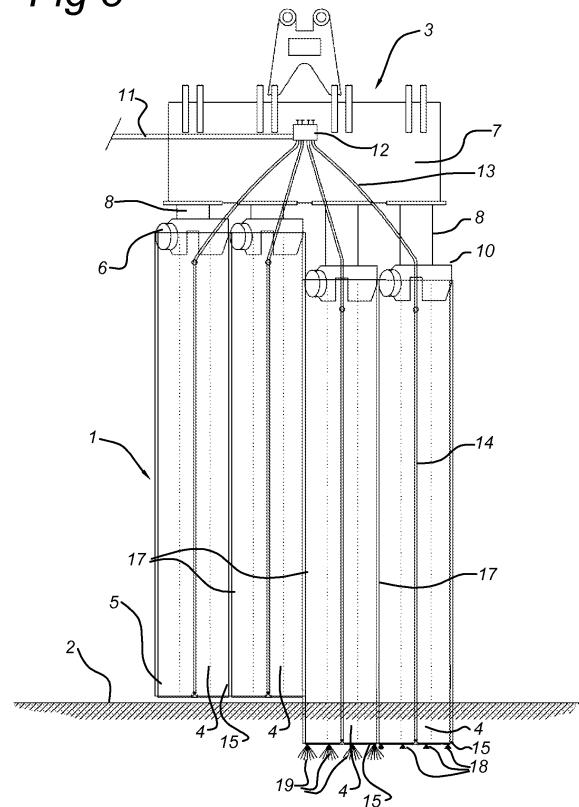

Description

[0001] The invention relates to driving a series of sheet pile planks which are displaceably coupled to one another into the ground. To this end, the series of sheet pile planks is first assembled, in which case they engage with one another along their longitudinal edges so as to be displaceable. The bottom edge of the series which is thus assembled is then placed on the ground. A drive-in apparatus engages with the upper edge of the series and can drive the various sheet pile planks individually into the ground and/or keep them stationary. Such a drive-in apparatus is known per se, and will therefore not be described in more detail. It has grippers, each of which can grip a sheet pile plank, and drive means for displacing the grippers with respect to one another. Driving into the ground can be carried out by, for example, static pressing by means of hydraulic piston/cylinder devices, vibrating and the like.

[0002] The speed at which sheet pile planks can be driven into the ground depends inter alia on the soil conditions. In this connection, it has already been proposed to fit an injection member to the bottom edge of the sheet pile plank. When the sheet pile plank is driven into the ground, the ground around its bottom edge is locally and temporarily softened by an injected medium, in such a manner that driving into the ground proceeds more easily and quickly. The known injection member may, for example, consist of a pipe which extends along the bottom edge of the sheet pile plank, which pipe has holes from which the medium flows out. The medium results in a softening of the soil material, but at the same time the flow has to be sufficiently powerful to prevent soil material from entering the holes. This is important in order to prevent the holes from becoming blocked and thus prevent the injection member from becoming inoperative.

[0003] Also when the sheet pile planks are driven into the ground in a series, as discussed above, it may be desirable to treat the ground by injecting a medium. In this case, however, driving the individual sheet pile planks in is carried out intermittently. This means that a certain sheet pile plank is initially driven into the ground over a distance which is significantly shorter than its own length. However, after it has been driven into the ground over a certain distance, the respective sheet pile plank is kept stationary. If an injection member were present at the bottom edge of the sheet pile plank, this could lead to problems since soil material can enter the holes and block them in this stationary position. For this reason, it has not been readily possible to assist in driving a series of sheet pile planks into the ground by injecting a medium into the ground.

[0004] However, it is an object of the invention to provide a method of the type mentioned in the preamble which does make use of the advantageous effect offered by injection of a medium into the ground. This is achieved by means of a method for driving a series of sheet pile planks which are displaceably coupled to one another in

the longitudinal direction into the ground, comprising the following steps:

- keeping at least one of the sheet pile planks stationary,
- driving at least one other sheet pile plank into the ground in such a manner that the other sheet pile plank which is driven into the ground is displaced with respect to the stationary sheet pile plank,
- subsequently keeping the sheet pile plank which has been driven into the ground stationary,
- subsequently driving a sheet pile plank which was initially kept stationary into the ground in such a manner that said sheet pile plank is displaced with respect to the stationary sheet pile plank which was driven into the ground,
- supplying a fluid to the bottom of a sheet pile plank, **characterized in that**
- the fluid is supplied at a relatively high pressure and/or a relatively high flow rate while the sheet pile plank is driven into the ground,
- the fluid is supplied at a relatively low pressure and/or a relatively low flow rate while the sheet pile plank is kept stationary.

[0005] When a sheet pile plank is driven into the ground using the method according to the invention, a continuous flow of the medium from the injection member is maintained, even during those stages in which the sheet pile plank is kept stationary. This has the advantageous effect that even during these stationary stages, material from the ground is prevented from collecting in the holes of the injection member as a result of the groundwater pressure. Also, a flow at a slight excess pressure is maintained from said holes which may, however, be significantly smaller than the flow which is required to drive the sheet pile plank into the ground. The injection member may be of a simple design, since no valves are necessary to prevent material from the ground from entering. The holes in the injection member may be permanently open without this causing a blockage which could result in obstruction during the stage when the sheet pile plank is driven into the ground, which follows a stationary stage.

[0006] This means that the method according to the invention can in particular comprise the following steps:

- using sheet pile planks comprising a permanently open nozzle at the bottom,
- while keeping the sheet pile plank stationary, supplying the fluid at a relatively low pressure with respect to the pressure during fluidization and/or at a relatively low flow rate with respect to the flow rate during fluidization in such a manner that blockage of the nozzle is prevented.

[0007] Furthermore, the method according to the invention may comprise the following steps:

- causing at least two individual drive-in devices to act on the series of sheet pile planks,
- repeatedly and alternately driving each sheet pile plank into the ground and keeping it stationary until the nominal depth position of the sheet pile plank has been reached.

[0008] The invention furthermore relates to a device for carrying out the method as described above, comprising individual drive-in means for individually acting on at least two sheet pile planks, pressure means for supplying fluid to the individual sheet pile planks at excess pressure, which pressure means are designed for optionally dispensing fluid either at a relatively high pressure and/or at a relatively high flow rate, on the one hand, or dispensing fluid at a relatively low pressure and/or a relatively low flow rate on the other hand, as well as control means for activating the drive-in means associated with a sheet pile plank, for simultaneously supplying the fluid at a relatively high pressure and/or a relatively high flow rate to said sheet pile plank and simultaneously supplying the fluid at a relatively low pressure and/or a relatively low flow rate to the sheet pile plank which is kept stationary.

[0009] Reference is made to the prior art as known from NL-A-1,004,237. In this case, sheet pile planks are used across the bottom edge from where a pipe with holes extends. The sheet pile planks are in each case driven into the ground in their entirety. In this case there is a constant flow of medium from the holes in the pipe, so that the risk of blockage does not play a part here. In addition, this prior art does not relate to driving a series of sheet pile planks into the ground intermittently.

[0010] The invention will now be described further with reference to an exemplary embodiment illustrated in the figures, in which:

Figs. 1-4 show different stages of driving a series of sheet pile planks into the ground.

Fig. 5 shows a perspective bottom view of two sheet pile planks in the series according to Figs. 1-4.

[0011] Fig. 1 shows a series 1 comprising four sheet pile planks 4. These sheet pile planks 4 are connected in pairs by lock connections 17 known per se which will not be described in more detail. The bottom edge 5 of the sheet pile planks 4 is arranged on the ground 2 into which the series 1 has to be driven. On the upper edge 6 of the sheet pile planks 4, the device for driving the series 4 into the ground is denoted overall by reference numeral 3. This device 3 has a housing 6 in which four individual drive-in devices 8 are accommodated. Each individual drive-in device 8 has a gripper 10 which acts on the upper edge 6 of an individual sheet pile plank 4.

[0012] The device 3 is suspended from a stand, which is known per se (not shown) for treating the series of sheet pile planks.

[0013] On the housing 7 of the device 3, a distributor 12 is also arranged which is provided with valves and to which a pressure pipe 11 is connected. Furthermore, liquid lines 13 are connected to the distributor 12, each of which leads to one of the sheet pile planks 4. Over the length of each sheet pile plank, a supply line 14 extends to which the associated liquid lines 13 are connected. On the underside of each supply line 14, the transverse line 15 illustrated in Fig. 5 is connected which has a series of holes 16 along its length.

[0014] In use, a liquid, for example water, is supplied to the pressure pipe 11 at an excess pressure by a pump (not shown). Initially, the valves in the distributor 12 are all closed. From the starting position shown in Fig. 1, one of the individual drive-in devices 8 is activated. At the same time, the liquid is supplied to the supply line 14 via the distributor 12 and the associated liquid lines 13 and is thus supplied to the transverse line 15. From the holes 16 in the transverse line 15, water 19 is thus injected into the ground under excess pressure, in such a manner that as a result of the softening of the ground in combination with the driving forces exerted by the drive-in device 8 on the respective sheet pile plank 4, the respective sheet pile plank is driven into the ground for a certain distance. Fig. 2 shows this first stage of introducing the series of sheet pile planks into the ground, with the sheet pile plank on the right-hand side having already been driven into the ground slightly.

[0015] When the associated right-hand individual drive-in device 8 has performed the maximum travel at which driving of the associated sheet pile plank 4 takes place, this drive-in device 8 is brought to a stationary position, with the respective sheet pile plank 4 also being brought into a stationary position. In the next step, illustrated in Fig. 3, the next sheet pile plank 4 is then driven into the ground along a certain length by means of the adjacent drive-in device 8. In this case, the distributor 12 delivers water which is now under excess pressure to said respective sheet pile plank, as a result of which water 19 is injected into the ground under excess pressure. Thus, as a result of the combined effect of the respective drive-in device 8 and the effect which occurs in the ground as a result of the water 19, this sheet pile plank can be driven into the ground over a certain length.

[0016] While this second sheet pile plank 4 is being driven into the ground, the first sheet pile plank 4 is stationary, as has already been said before. However, according to the invention, the distributor 12 also delivers a certain amount of water to the transverse line 15 of this first sheet pile plank 4, which is in a stationary position because the associated drive-in device 8 is switched off. This means that water 18 is also injected into the ground from the holes 16 of this transverse line, albeit at a lower pressure and/or with a lower flow rate than the water flow 19 which is used with the next sheet pile plank which is in the stage of being driven into the ground. The advantage of supplying an amount of water to the stationary sheet pile plank is that the holes 16 in the transverse line

15 thereof do not become blocked in the stationary position. The fact is that an excess pressure may build up in the ground as a result of the injection of water, so that water mixed with soil material could end up in the holes 16 and thus in the transverse line 15 if there were no counterpressure.

[0017] The above-described process is repeated by then driving the third sheet pile plank 4 into the ground using a water flow 19 having a relatively high pressure and/or a relatively high flow rate, and by simultaneously causing a certain water flow 18 (having a relatively low pressure and/or low flow rate) to flow from the holes 16 of the transverse line 15 of the preceding two sheet pile planks 4. Eventually, the entire series 1 of sheet pile planks 4 can thus be driven into the ground by a certain distance. Subsequently, the first sheet pile plank is again driven further into the ground, with liquid at a higher pressure and/or at a higher flow rate being supplied to said sheet pile plank, so that, in combination with the action of the associated drive-in device 8, said sheet pile plank 4 can be driven into the ground by a certain distance. In this case, the supply of water at a certain excess pressure to the other three sheet pile planks is maintained, so that no blockage can occur in the transverse line 15 thereof. After a number of such cycles 1, the entire series has been driven into the ground.

List of reference numerals

[0018]

1. Series of sheet pile planks
2. Ground
3. Device for driving the series into the ground
4. Sheet pile plank
5. Bottom edge of sheet pile plank
6. Top edge of sheet pile plank
7. Housing of device 3
8. Individual drive-in device
10. Gripper
11. Pressure pipe
12. Distributor
13. Liquid line
14. Supply line
15. Transverse line
16. Holes in the transverse line
17. Lock connection
18. Low-pressure and/or low flow rate waterflow
19. High-pressure and/or high flow rate waterflow

Claims

1. Method for driving a series (1) of sheet pile planks (4) which are displaceably coupled to one another in the longitudinal direction into the ground, comprising the following steps:

- keeping at least one of the sheet pile planks (4) stationary,
- driving at least one other sheet pile plank (4) into the ground in such a manner that the other sheet pile plank which is driven into the ground is displaced with respect to the stationary sheet pile plank,
- subsequently keeping the sheet pile plank (4) which has been driven into the ground stationary,
- subsequently driving a sheet pile plank (4) which was initially kept stationary into the ground in such a manner that said sheet pile plank is displaced with respect to the stationary sheet pile plank which was driven into the ground,
- supplying a fluid (19) to the bottom of a sheet pile plank,

characterized in that

- the fluid (19) is supplied at a relatively high pressure and/or a relatively high flow rate while the sheet pile plank (4) is driven into the ground,
- the fluid (18) is supplied at a relatively low pressure and/or a relatively low flow rate while the sheet pile plank is kept stationary.

2. Method according to Claim 1, comprising the following steps:

- using sheet pile planks (4) comprising a permanently open nozzle (15, 16) at the bottom (5),
- while keeping the sheet pile plank stationary, supplying the fluid (18) at a relatively low pressure with respect to the pressure during fluidization and/or at a relatively low flow rate with respect to the flow rate during fluidization in such a manner that blockage of the nozzle (15, 16) is prevented.

3. Method according to one of the preceding claims, comprising the following steps:

- causing at least two individual drive-in devices (8) to act on the series of sheet pile planks (4),
- repeatedly and alternately driving each sheet pile plank into the ground and keeping it stationary until the nominal depth position of the sheet pile plank has been reached.

4. Method according to one of the preceding claims, in which each sheet pile plank (4) is acted on by a dedicated associated drive-in device (8).

5. Method according to one of the preceding claims, in which the drive-in device (8) is designed for static pressing, ramming, vibrating and the like.

6. Device for carrying out the method according to one of the preceding claims, comprising individual drive-in means (8) for individually acting on at least two sheet pile planks (4), pressure means (11, 12, 13) for supplying fluid to the individual sheet pile planks (4) at excess pressure, which pressure means are designed for optionally dispensing fluid (19) either at a relatively high pressure and/or at a relatively high flow rate, on the one hand, or dispensing fluid (18) at a relatively low pressure and/or a relatively low flow rate, on the other hand, as well as control means for activating the drive-in devices (8) associated with a sheet pile plank, for simultaneously supplying the fluid (19) at a relatively high pressure and/or a relatively high flow rate to said sheet pile plank and simultaneously supplying the fluid (18) at a relatively low pressure and/or a relatively low flow rate to the sheet pile plank which is kept stationary.

5

10

15

20

25

30

35

40

45

50

55

Fig 1

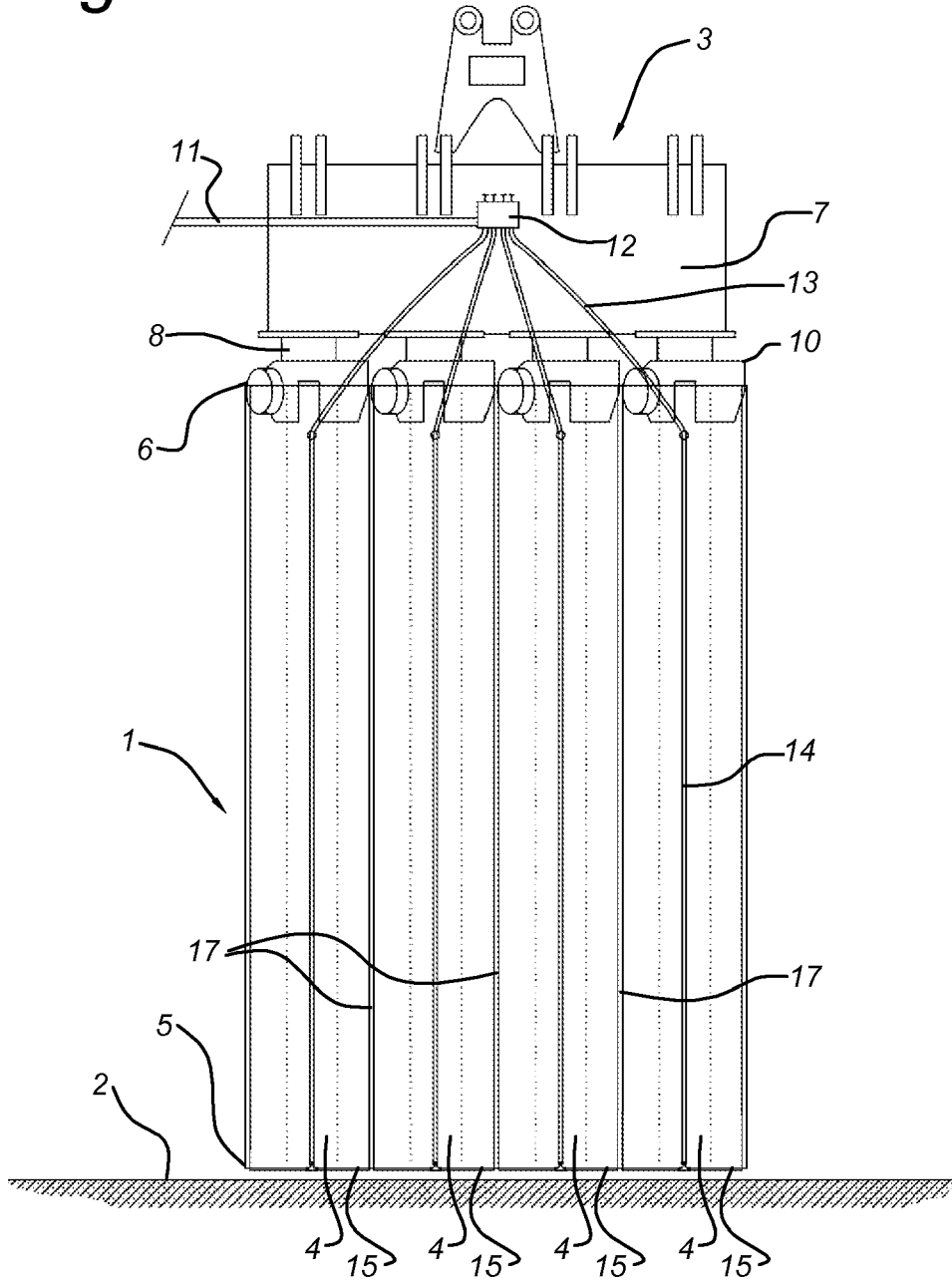

Fig 2

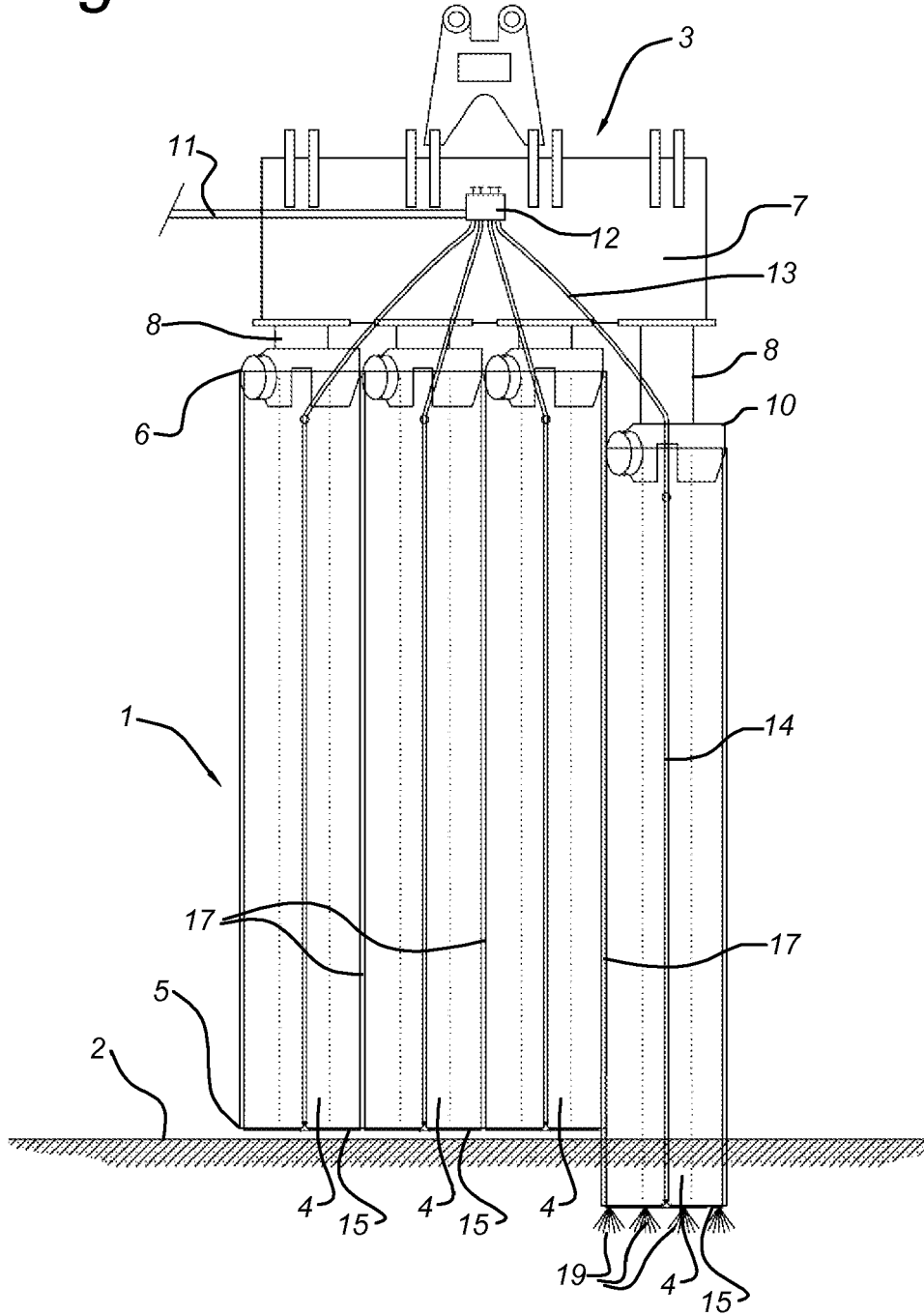

Fig 3

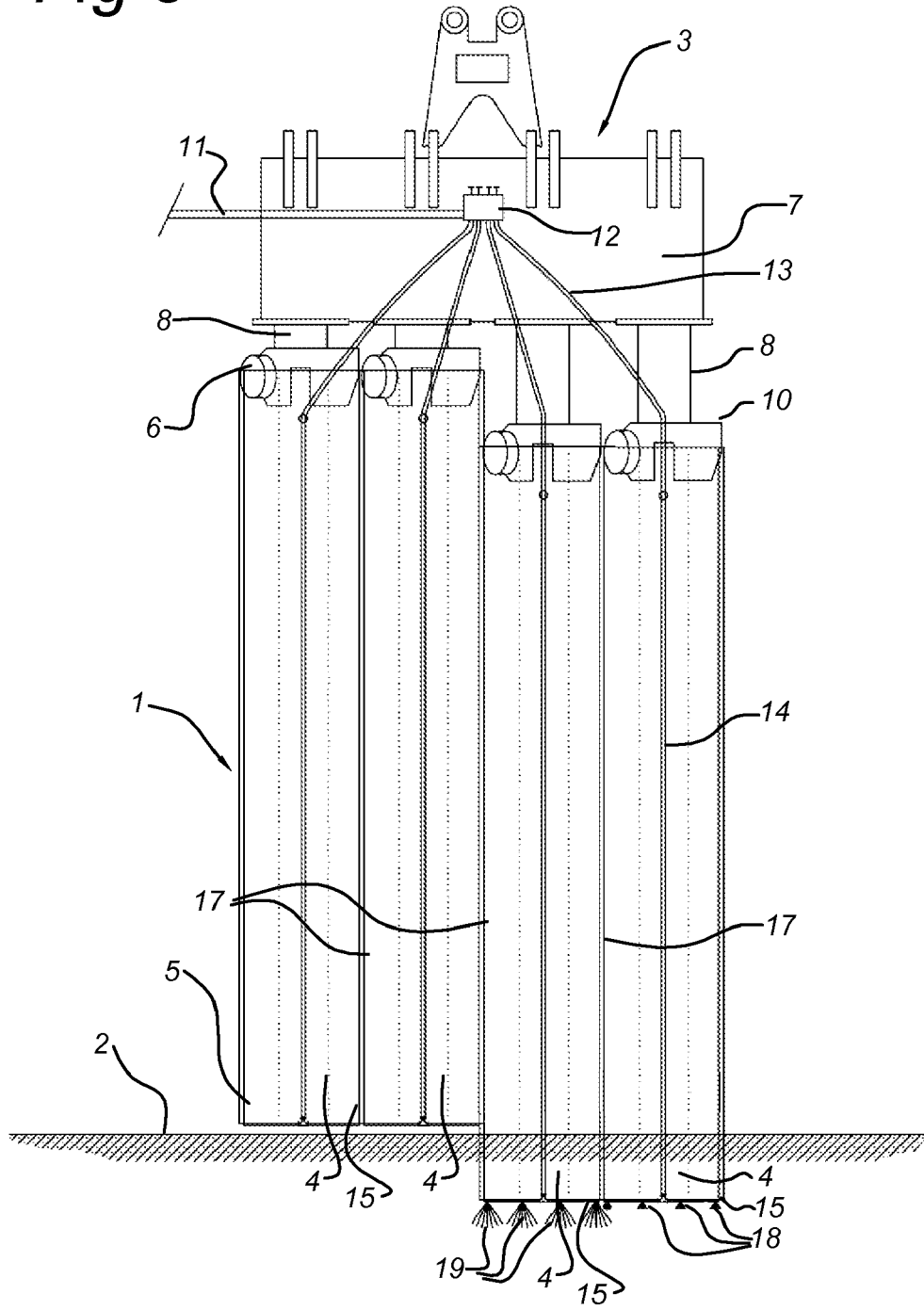

Fig 4

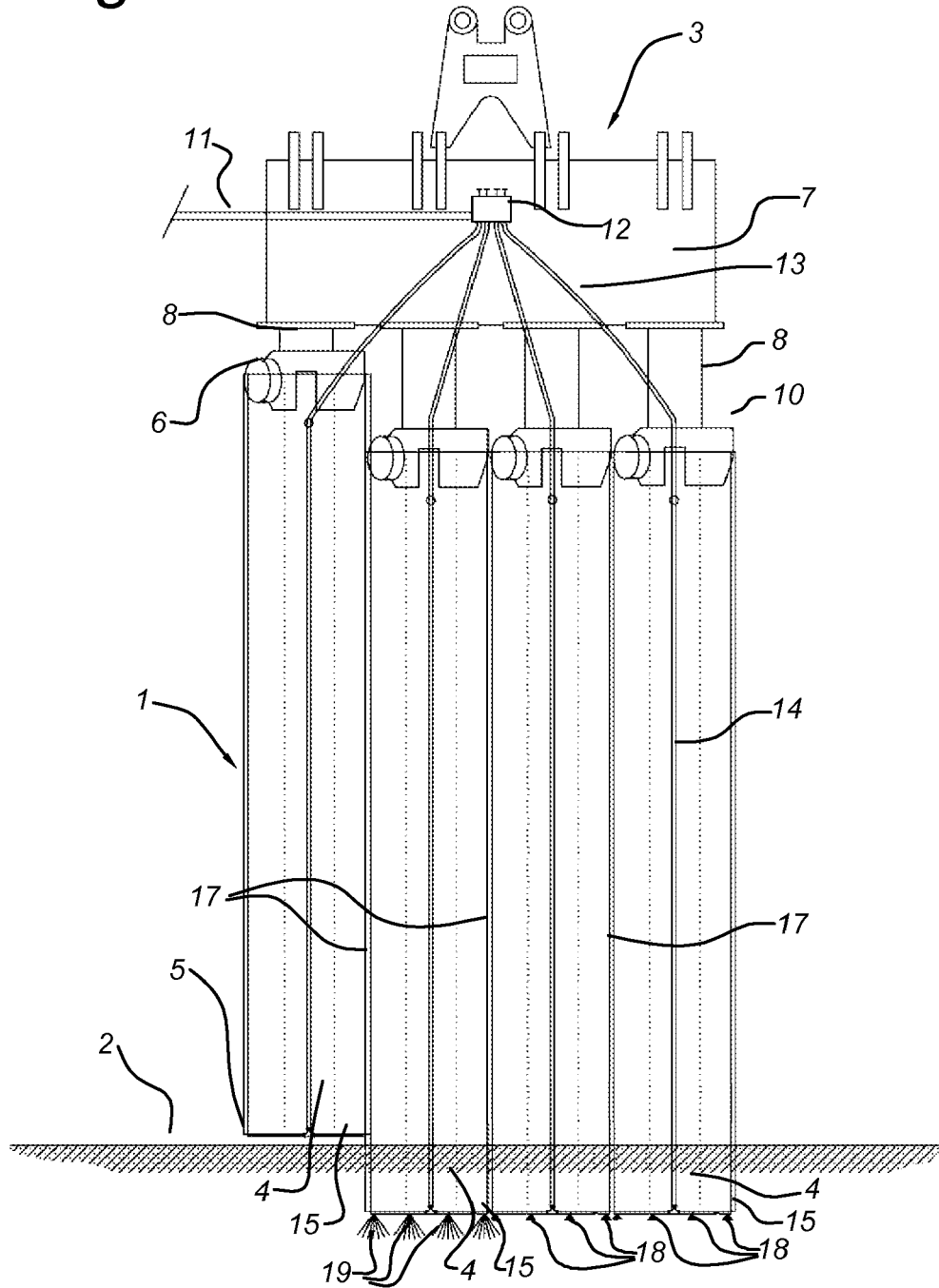
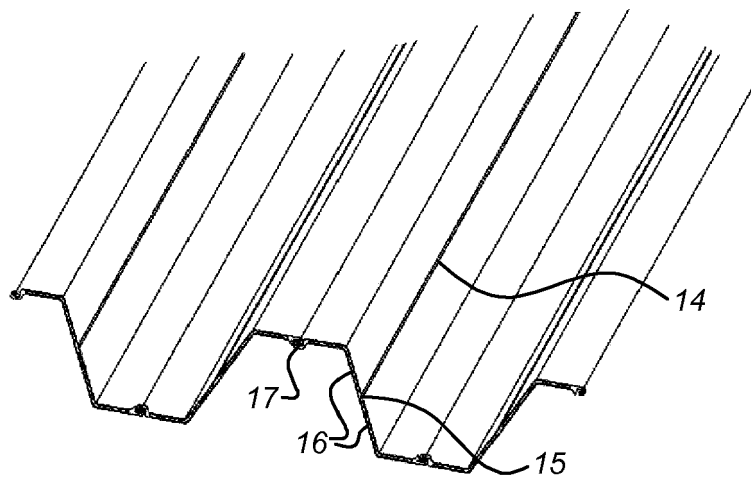

Fig 5





EUROPEAN SEARCH REPORT

Application Number
EP 10 15 3248

| DOCUMENTS CONSIDERED TO BE RELEVANT | | | |
|--|---|---|---|
| Category | Citation of document with indication, where appropriate, of relevant passages | Relevant to claim | CLASSIFICATION OF THE APPLICATION (IPC) |
| A | JP 06 101229 A (GIKEN SEISAKUSHO KK) 12 April 1994 (1994-04-12) * abstract; figure 1 * ----- | 1-6 | INV. E02D7/24 E02D7/26 |
| A | EP 1 717 375 A (BAUER MASCHINEN GMBH [DE]) 2 November 2006 (2006-11-02) * abstract; figure 2 * ----- | 1-6 | |
| A | FR 2 825 105 A (PROFILARBES SA [LU]) 29 November 2002 (2002-11-29) * page 5, line 29 - page 6, line 7 * * page 2, lines 13,14 * ----- | 1-6 | |
| A | WO 98/15692 A (HALTEREN TIJMEN VAN [NL]) 16 April 1998 (1998-04-16) * page 2, lines 20-27; figure 1 * ----- | 1-6 | |
| A | FR 2 664 833 A (PROCEDES TECH CONSTRUCTION [FR]) 24 January 1992 (1992-01-24) * page 6, paragraph 3 * ----- | 1-6 | |
| A | DATABASE WPI Week 200835 Thomson Scientific, London, GB; AN 2008-F25464 XP002543130 & KR 2007 117 237 A (DAE WANG E & C CO LTD) 12 December 2007 (2007-12-12) * abstract * ----- | 1-6 | |
| The present search report has been drawn up for all claims | | | |
| Place of search The Hague | | Date of completion of the search 31 March 2010 | Examiner Leroux, Corentine |
| CATEGORY OF CITED DOCUMENTS X : particularly relevant if taken alone Y : particularly relevant if combined with another document of the same category A : technological background O : non-written disclosure P : intermediate document | | T : theory or principle underlying the invention E : earlier patent document, but published on, or after the filing date D : document cited in the application L : document cited for other reasons & : member of the same patent family, corresponding document | |

2
EPO FORM 1503 03/02 (P04C01)

ANNEX TO THE EUROPEAN SEARCH REPORT
ON EUROPEAN PATENT APPLICATION NO.

EP 10 15 3248

This annex lists the patent family members relating to the patent documents cited in the above-mentioned European search report.
The members are as contained in the European Patent Office EDP file on
The European Patent Office is in no way liable for these particulars which are merely given for the purpose of information.

31-03-2010

| Patent document cited in search report | | Publication date | Patent family member(s) | Publication date |
|---|---|---------------------|----------------------------|---------------------|
| JP 6101229 | A | 12-04-1994 | JP 2520827 B2 | 31-07-1996 |
| EP 1717375 | A | 02-11-2006 | NONE | |
| FR 2825105 | A | 29-11-2002 | NONE | |
| WO 9815692 | A | 16-04-1998 | AT 234393 T | 15-03-2003 |
| | | | DE 69719820 D1 | 17-04-2003 |
| | | | DE 69719820 T2 | 18-12-2003 |
| | | | DK 1012405 T3 | 07-07-2003 |
| | | | EP 1012405 A1 | 28-06-2000 |
| | | | ES 2197368 T3 | 01-01-2004 |
| | | | NL 1004237 C2 | 14-04-1998 |
| | | | PT 1012405 E | 31-07-2003 |
| FR 2664833 | A | 24-01-1992 | NONE | |
| KR 2007117237 | A | | NONE | |

REFERENCES CITED IN THE DESCRIPTION

This list of references cited by the applicant is for the reader's convenience only. It does not form part of the European patent document. Even though great care has been taken in compiling the references, errors or omissions cannot be excluded and the EPO disclaims all liability in this regard.

Patent documents cited in the description

- NL 1004237 A [0009]