



(11) **EP 2 223 626 A1**

(12) **EUROPEAN PATENT APPLICATION**
published in accordance with Art. 153(4) EPC

(43) Date of publication:
01.09.2010 Bulletin 2010/35

(51) Int Cl.:
A45D 2/36 ^(2006.01) **A45D 7/06** ^(2006.01)
A45D 20/12 ^(2006.01) **H01H 15/00** ^(2006.01)

(21) Application number: **08715392.0**

(86) International application number:
PCT/CN2008/070660

(22) Date of filing: **01.04.2008**

(87) International publication number:
WO 2009/074022 (18.06.2009 Gazette 2009/25)

(84) Designated Contracting States:
AT BE BG CH CY CZ DE DK EE ES FI FR GB GR HR HU IE IS IT LI LT LU LV MC MT NL NO PL PT RO SE SI SK TR
Designated Extension States:
AL BA MK RS

(72) Inventors:
• **KEONG, Wai Ho**
Hong Kong (CN)
• **LOK, Chun Yin**
Hong Kong (CN)

(30) Priority: **07.12.2007 CN 200720311946 U**

(74) Representative: **Müller-Boré & Partner**
Patentanwälte
Grafinger Straße 2
81671 München (DE)

(71) Applicant: **Kenford Industrial Co., Ltd.**
Hong Kong (CN)

(54) **HAIR STRAIGHTENER WITH CLIP STRUCTURE**

(57) A hair straightener with a clip structure comprises electric heating elements (2), an ion generator (4), a three-dimensional control interface (1) having a button (33), a display screen (5), a linking member (6), an upper arm (7) and a lower arm (8). The upper arm (7) and the lower arm (8) are linked with each other through the linking member (6), so as to form the clip structure. The three-

dimensional control interface (1) simultaneously connects with and controls other different functional elements of the hair straightener, and adjusts at least one functional element through the button (33), so as to adjust different functions of the hair straightener, including the temperature adjustment of the electric heating elements (2) and the adjustment of the ion generator (4).

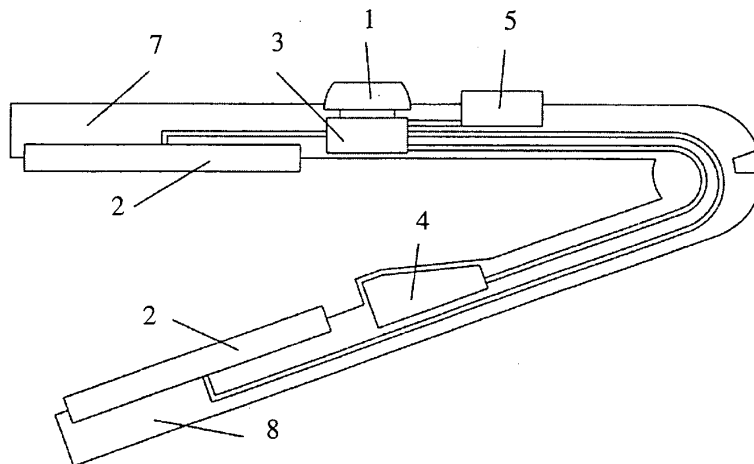

Fig. 2

EP 2 223 626 A1

Description

FIELD OF THE INVENTION

[0001] This present invention relates generally to hair care products, and more specifically, to a hair straightener with a clip structure utilizing electric heating.

BACKGROUND OF THE INVENTION

[0002] There are wide varieties of electric perm equipments currently. For example, a China patent no. ZL200520035229.7 discloses a hair straightener, comprising hinged electric clamping plates, wherein an upper clamping plate and a lower clamping plate are placed at a free end of the electric plates respectively, and an upper and a lower electric heating sheets are installed correspondingly on the inner side of the upper and lower clamping plates. The upper and the lower clamping plates are arranged as two blocks of porous structure. Such a hair straightener, and many other similar hair straighteners usually have a control interface in the manner of a flat button, therefore operation of the hair straighteners when used by users is very inconvenient. In addition, the existing hair straighteners only simply utilize electric heating or ion to straighten hair, and the effect for hair straightening is not very good.

SUMMARY OF THE INVENTION

[0003] The technical problem to be solved of the preset invention is to provide a hair straightener having a three-dimensional control interface which can provide control to hair straightening via electric heating or ion, in order to overcome the above-mentioned disadvantages of the prior art.

[0004] According an aspect of the present invention, a hair straightener with a clip structure is provided, comprising: electric heating elements, an ion generator, a three-dimensional control interface having a button, a linking member, an upper arm and a lower arm, wherein the upper arm and the lower arm are linked with each other through the linking member to form the clip structure; the three-dimensional control interface simultaneously connects with and controls other different functional elements of the hair straightener.

[0005] Advantageously, the three-dimensional control interface has a base with a displacement, and the button is embedded into the displacement, and is capable of displacing back and forth along the displacement. The three-dimensional control interface controls at least one functional element or adjusts the functional elements through the button displacing along the displacement, including adjusting temperature of the electric heating elements and adjusting the ion generator.

[0006] Advantageously, the three-dimensional control interface controls the hair straightener through the button displacing toward different directions, including the direc-

tions between the negative X-axis, the positive X-axis, the negative Y-axis, the positive Y-axis, the negative Z-axis, and the positive Z-axis, and the negative X-axis, the positive X-axis, the negative Y-axis, the positive Y-axis, the negative Z-axis, and the positive Z-axis of the same button.

[0007] Advantageously, the three-dimensional control interface is changeable toward different directions, and the button is capable of displacing toward different directions to control the hair straightener, wherein the different directions include directions between the negative X-axis, the positive X-axis, the negative Y-axis, the positive Y-axis, the negative Z-axis, and the positive Z-axis, and the negative X-axis, the positive X-axis, the negative Y-axis, the positive Y-axis, the negative Z-axis, and the positive Z-axis of the same button.

[0008] Advantageously, said other different functional elements of the hair straightener which are controlled by the three-dimensional control interface comprise a switch and a display of the hair straightener.

[0009] Advantageously, the button of the three-dimensional control interface has arbitrary shape, such as rod-shaped or cross-shaped.

[0010] Advantageously, the hair straightener includes two arms, which are linked together through the linking member to form the clip structures.

[0011] Advantageously, the two arms have an inner side and an outer side opposite to each other, respectively, and the electric heating elements are attached to the inner sides of the arms, while the ion generator is attached to the inner side of one of the two arms.

[0012] Advantageous effect of the present invention lies in as below: 1) the three-dimensional control interface is easy to use; 2) the hair straightener combines the thermal effect of the heating element with the ionic effect to achieve the purpose of straightening hair, thus the hair straightening effect is better; 3) working status of the hair straightener is shown on the display to facilitate the users adjusting the hair straightener.

BRIEF DESCRIPTION OF THE DRAWINGS

[0013] The accompanying drawings illustrate one or more embodiments of the invention and, together with the written description, serve to explain the principles of the invention, and wherein:

Fig. 1 is a structural diagram of a hair straightener of the present invention.

Fig. 2 is a structural diagram showing inner structure of the hair straightener in accordance with a first embodiment of the present invention.

Fig. 3a, Fig. 3b, and Fig. 3c are structural diagrams of a control interface of the hair straightener in accordance with the first embodiment of the present invention.

Fig. 4a, Fig. 4b, Fig. 4c, and Fig. 4d are structural diagrams of the control interface of the hair straight-

ener in accordance with the first embodiment of the present invention.

Fig. 5a, Fig. 5b and Fig. 5c are structural diagrams showing the control interface and the inner structure of the hair straightener in accordance with other two embodiments of the present invention, respectively. Fig. 6a, Fig. 6b, and Fig. 6c are structural diagrams of the hair straightener in accordance with further three different embodiments of the present invention.

Fig. 7 is a circuit diagram showing electrical connection of the hair straightener with a clip structure in accordance with an embodiment of the present invention.

DETAILED DESCRIPTION OF THE INVENTION

[0014] As shown in Fig. 1 and Fig. 2, a first embodiment of the present invention comprises the following components: a three-dimensional control interface 1, electric heating elements 2, a control unit 3, an ion generator 4, a display 5, a hinge 6, an upper arm 7, and a lower arm 8. The upper arm 7 is movably linked with the lower arm 8 through the hinge 6, that is, the hinge 6 is used as a linking member. A electric heating element 2, the three-dimensional control interface 1, and the display 5 are arranged on the upper arm 7, while the ion generator 4 and a electric heating element 2 are arranged on the lower arm 8, wherein the electric heating element 2 is attached to an inner side of the upper arm 7, opposite the other electric heating element 2 attached to an inner side of the lower arm 8. The three-dimensional control interface 1 is attached to an outer side of the upper arm 7, and the display 5 is also attached to the outer side of the upper arm 7. The ion generator 4 is attached to the inner side of the lower arm 8, near the hinge 6. Fig. 2 shows the control unit 3 below the three-dimensional control interface 1. The control unit 3 connects the three-dimensional control interface 1, the electric heating elements 2, the ion generator 4, and the display 5 into a functional related whole one via wires.

[0015] Fig. 3a, Fig. 3b, and Fig. 3c are structural diagrams of the control interface 1 of the hair straightener in accordance with the first embodiment of the present invention. A button on the three-dimensional control interface 1 may displace back and forth toward four horizontal directions indicated by 11, 12, 13 and 14, and may displace back and forth toward two vertical directions indicated by 15 and 16.

[0016] Fig. 4a, Fig. 4b, Fig. 4c, and Fig. 4d are structural diagrams of the control interface of the hair straightener in accordance with the first embodiment of the present invention. As shown in these figures, in the right hand coordinate system, the four directions 11, 12, 13, 14 are four directions in a plane defined by X-axis and Y-axis, the directions 15, 16 are two directions in Z-axis, wherein, the direction 14 corresponds to the positive X-axis, while the direction 13 corresponds to the negative

X-axis; the direction 11 corresponds to the positive Y-axis, while the direction 12 corresponds to the negative Y-axis; the direction 15 corresponds to the positive Z-axis, while the direction 16 corresponds to the negative Z-axis. The button of the three-dimensional control interface 1 may displace back and forth in the above directions.

[0017] Fig. 5a and Fig. 5b are structural diagrams showing the control interface 1 of the hair straightener in accordance with two embodiments of the present invention. In the embodiment as shown in Fig. 5a, the button 33 of the three-dimensional control interface 1 may displace along a straight line path 17 to reach different positions. In the embodiment as shown in Fig. 5b, the button of the three-dimensional control interface 1 may displace along a arc path 18 to reach different positions.

[0018] Fig. 5c is a structural diagram showing the inner structure of the control interface 1 of the hair straightener in accordance with an embodiment of the present invention. As shown in Fig. 5c, the three-dimensional control interface 1 comprises a base 31 having a cross-shaped displacement 32, and a button 33 embedded into the displacement 32. The button 33 may displace back and forth along the displacement 32 toward the four horizontal directions and the two vertical directions as shown in Fig. 3 and Fig. 4.

[0019] Fig. 6a, Fig. 6b, and Fig. 6c are structural diagrams of the hair straightener in accordance with further three different embodiments of the present invention. In the embodiment as shown in Fig. 6a, the upper arm is linked with the lower arm through a hinge, which is positioned at the end of the upper arm and the lower arm away from the electric heating elements. This hinge is equivalent to a linking member. In the embodiment as shown in Fig. 6b, the upper arm is linked with the lower arm through a hinge, but this embodiment is different from that in Fig. 6a that the hinge is positioned in the middle of the upper arm and the lower arm respectively. Both Fig. 6a and Fig. 6b show the embodiments that the two opposite heating elements, which are attached to the inner sides of the upper and the lower arms respectively, are close to each other through rotation of the upper arm and the lower arm about the hinge. In such a manner, hair to be straightened is clamped. In the embodiment as shown in Fig. 6c, the upper arm is connected with the lower arm through a linking member 19. A sildeway 20 is arranged at one side of the linking member 19, and the upper arm and the lower arm are embedded into the displacement 20 of the linking member 19 respectively. The upper arm and the lower arm may displace in the displacement 20 to facilitate the two opposite heating elements attached to the inner sides of the upper and the lower arms closing to each other, such that hair to be straightened is clamped, then the hair are heated to be curled.

[0020] Fig. 7 is a circuit diagram showing electrical connection of the hair straightener with a clip structure in accordance with an embodiment of the present inven-

tion. As a center, the control unit 3 connects the three-dimensional control interface 1, the electric heating elements 2, the ion generator 4, the display 5, the relevant elements 9, and the power supply 10 into a whole one via wire connections. The display 5 is a LCD display screen. The relevant elements 9 may comprise a power indicator, a working status indicator, a buzzer alarm and so on. The hair straightener of the present invention utilizes AC power supply.

Claims

1. A hair straightener with a clip structure, comprising electric heating elements (2), an ion generator (4), a three-dimensional control interface (1) having a button (33), a linking member (6), an upper arm (7) and a lower arm (8), the upper arm (7) and the lower arm (8) being linked with each other through the linking member (6) to form the clip structure, **characterized in that**, the three-dimensional control interface (1) simultaneously connects with and controls other different functional elements of the hair straightener. 5
2. The hair straightener with a clip structure according to claim 1, wherein the three-dimensional control interface (1) has a base (31) with a displacement (32), and the button (33) is embedded into the displacement (32) and is capable of displacing back and forth along the displacement (32). 10
3. The hair straightener with a clip structure according to claim 1, wherein the three-dimensional control interface (1) controls at least one functional element or adjusts the functional elements through displacing of the button (33), including adjusting temperature of the electric heating elements (2) and adjusting the ion generator (4). 15
4. The hair straightener with a clip structure according to claim 1, wherein the three-dimensional control interface (1) controls the hair straightener through the button (33) displacing toward different directions, including the directions between the negative X-axis, the positive X-axis, the negative Y-axis, the positive Y-axis, the negative Z-axis, and the positive Z-axis, and the negative X-axis, the positive X-axis, the negative Y-axis, the positive Y-axis, the negative Z-axis, and the positive Z-axis of the same button. 20
5. The hair straightener with a clip structure according to claim 1, wherein the three-dimensional control interface (1) is changeable toward different directions, and the button (33) is capable of displacing toward different directions to control the hair straightener, wherein the different directions include directions between the negative X-axis, the positive X-axis, the 25
- negative Y-axis, the positive Y-axis, the negative Z-axis, and the positive Z-axis, and the negative X-axis, the positive X-axis, the negative Y-axis, the positive Y-axis, the negative Z-axis, and the positive Z-axis of the same button (33). 30
6. The hair straightener with a clip structure according to claim 1, wherein said other different functional elements of the hair straightener which are controlled by the three-dimensional control interface (1) comprise a switch and a display (5) of the hair straightener. 35
7. The hair straightener with a clip structure according to claim 1, wherein the button (33) of the three-dimensional control interface (1) has arbitrary shape. 40
8. The hair straightener with a clip structure according to claim 7, wherein the two arms (7, 8) have an inner side and an outer side opposite to each other, respectively, and the electric heating elements (2) are attached to the inner sides of the arms (7, 8), while the ion generator (4) is attached to the inner side of one of the two arms. 45
9. The hair straightener with a clip structure according to claim 8, wherein the two arms (7, 8) are linked through the linking member (6) to form the clip structure, the three-dimensional control interface (1) is attached to the outer side of one of the two arms. 50
10. The hair straightener with a clip structure according to claim 9, wherein the two arms (7, 8) are connected through the linking member (6) at their ends or through the linking member (6) at respective ends of the two arms to form the clip structure. 55

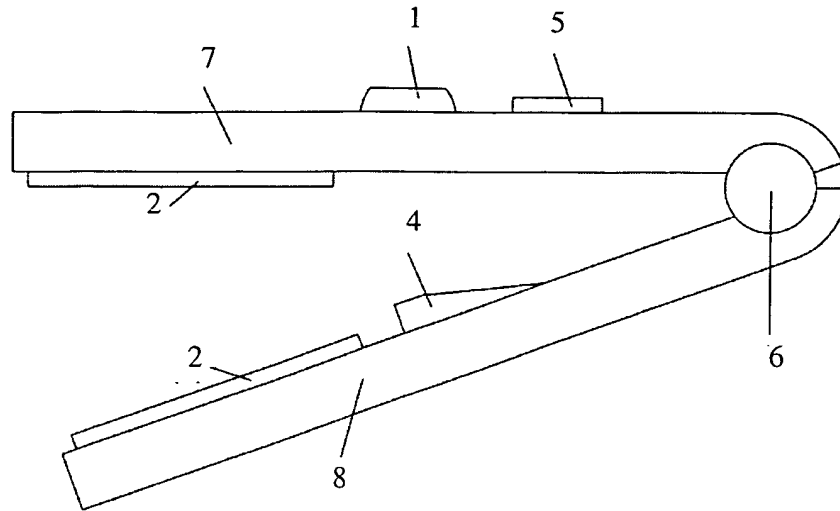

Fig. 1

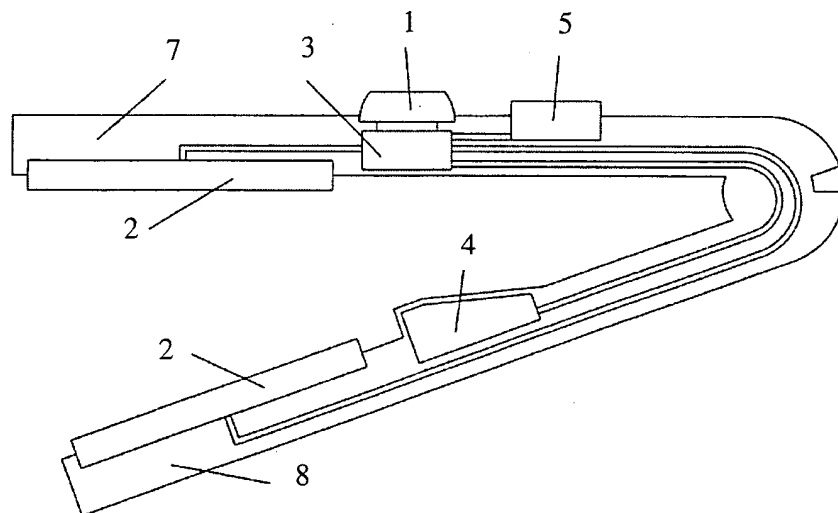

Fig. 2

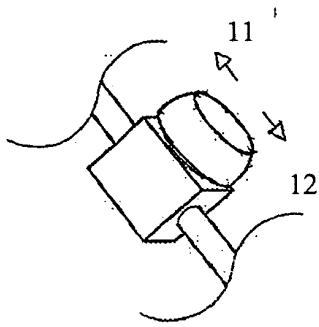

Fig. 3a

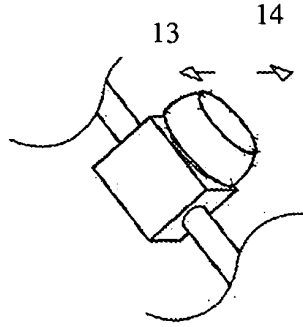

Fig. 3b

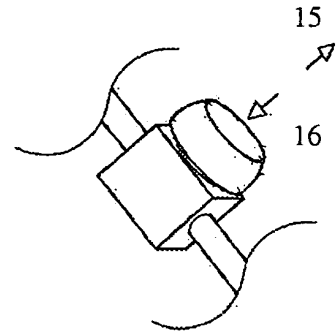

Fig. 3c

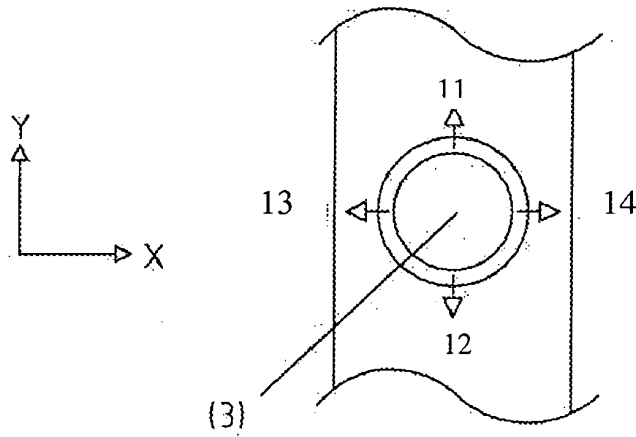

Fig. 4

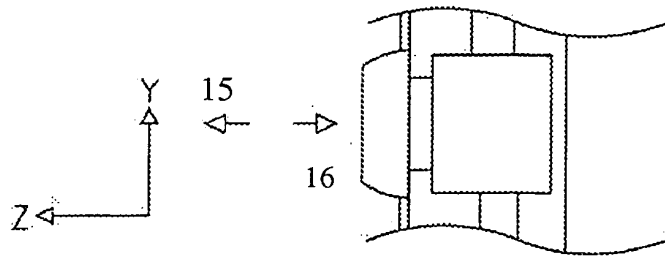

Fig. 4b

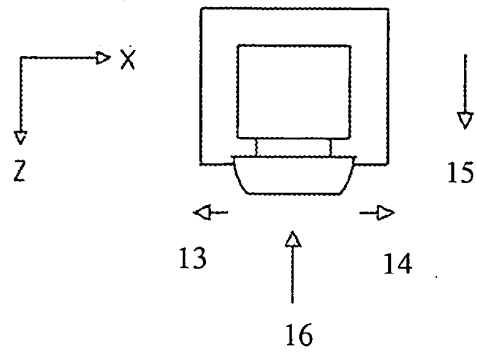

Fig. 4c

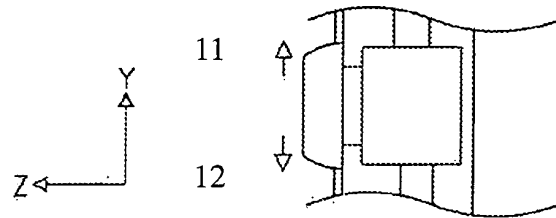

Fig. 4d

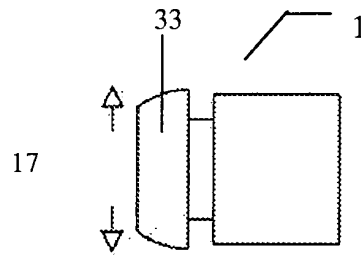

Fig. 5a

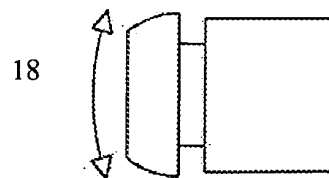

Fig. 5b

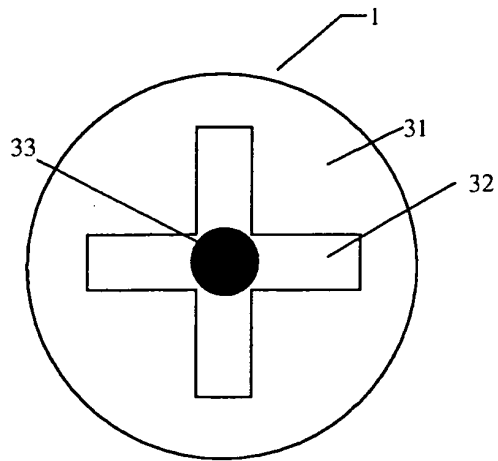

Fig. 5c

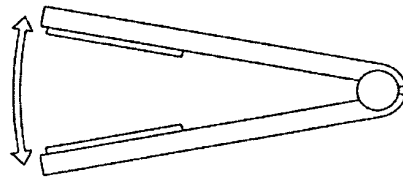

Fig. 6a

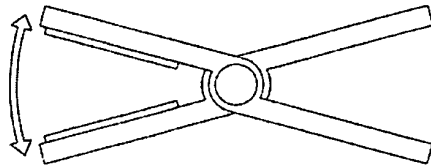

Fig. 6b

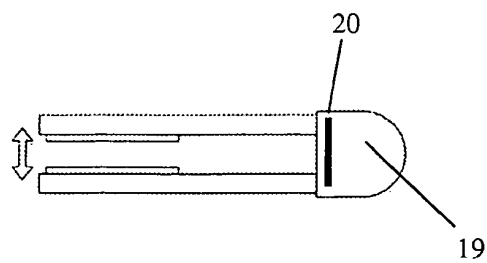

Fig. 6c

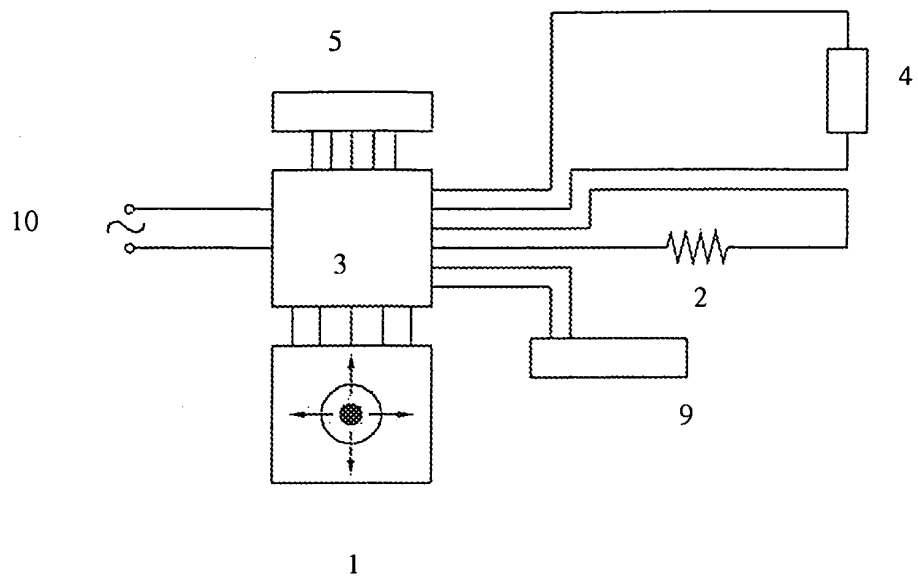

Fig. 7

INTERNATIONAL SEARCH REPORT

International application No.

PCT/CN2008/070660

A. CLASSIFICATION OF SUBJECT MATTER		
See extra sheet		
According to International Patent Classification (IPC) or to both national classification and IPC		
B. FIELDS SEARCHED		
Minimum documentation searched (classification system followed by classification symbols)		
IPC: A45D2, A45D7, A45D20, H01H15, H01H19, H01H21		
Documentation searched other than minimum documentation to the extent that such documents are included in the fields searched		
Electronic data base consulted during the international search (name of data base and, where practicable, search terms used)		
CNKI, CNPAT, WPI, EPODOC, PAJ: switch??? control???? adjust??? interface? ion?		
C. DOCUMENTS CONSIDERED TO BE RELEVANT		
Category*	Citation of document, with indication, where appropriate, of the relevant passages	Relevant to claim No.
Y	WO2005/102100A2 (HELEN OF TROY LTD) 03 Nov.2005 (03.11.2005) Fig.5, and line 17, page 3 to line 6, page 4	1-10
Y	CN2912334Y (KENFORD INDUSTRIAL CO., LTD) 20 Jun.2007 (20.06.2007) Figs.1-8, and line 18, page 3 to line 22, page 4	1-10
Y	CN200953912Y (KENFORD INDUSTRIAL CO., LTD) 03 Oct.2007 (03.10.2007) Fig.7a, and lines 11-19, page 4	10
A	JP9-262120A (MATSUSHITA ELECTRIC WORKS LTD) 07 Oct.1997 (07.10.1997) the whole document	1-10
A	WO2005/099509A2 (CONAIR CORP et al.) 27 Oct.2005 (27.10.2005) the whole document	1-10
<input checked="" type="checkbox"/> Further documents are listed in the continuation of Box C. <input checked="" type="checkbox"/> See patent family annex.		
* Special categories of cited documents:	"T" later document published after the international filing date or priority date and not in conflict with the application but cited to understand the principle or theory underlying the invention "X" document of particular relevance; the claimed invention cannot be considered novel or cannot be considered to involve an inventive step when the document is taken alone "Y" document of particular relevance; the claimed invention cannot be considered to involve an inventive step when the document is combined with one or more other such documents, such combination being obvious to a person skilled in the art "&" document member of the same patent family	
"A" document defining the general state of the art which is not considered to be of particular relevance		
"E" earlier application or patent but published on or after the international filing date		
"L" document which may throw doubts on priority claim (S) or which is cited to establish the publication date of another citation or other special reason (as specified)		
"O" document referring to an oral disclosure, use, exhibition or other means		
"P" document published prior to the international filing date but later than the priority date claimed		
Date of the actual completion of the international search 26 Aug.2008 (26.08.2008)	Date of mailing of the international search report 18 Sep. 2008 (18.09.2008)	
Name and mailing address of the ISA/CN The State Intellectual Property Office, the P.R.China 6 Xitucheng Rd., Jimen Bridge, Haidian District, Beijing, China 100088 Facsimile No. 86-10-62019451	Authorized officer SHANG, AIXUE Telephone No. (86-10) 62085591	

Form PCT/ISA/210 (second sheet) (April 2007)

INTERNATIONAL SEARCH REPORT

International application No.

PCT/CN2008/070660

C (Continuation). DOCUMENTS CONSIDERED TO BE RELEVANT

Category*	Citation of document, with indication, where appropriate, of the relevant passages	Relevant to claim No.
A	US6223753B1 (Zhen-Xing Lo) 01 May 2001 (01.05.2001) the whole document	1-10
A	CN1871971A (MATSUSHITA ELECTRIC WORKS LTD) 06 Dec.2006 (06.12.2006) the whole document	1-10

Form PCT/ISA/210 (continuation of second sheet) (April 2007)

INTERNATIONAL SEARCH REPORT
Information on patent family members

International application No.

PCT/CN2008/070660

Patent Documents referred in the Report	Publication Date	Patent Family	Publication Date
WO2005/102100A2	03.11.2005	US2005224091A1	13.10.2005
		EP1732412A2	20.12.2006
		AU2005235147A1	03.11.2005
		JP2007532177T	15.11.2007
CN2912334Y	20.06.2007	US2007169369A1	26.07.2007
CN200953912Y	03.10.2007	None	
JP9-262120A	07.10.1997	None	
WO2005/099509A2	27.10.2005	US2005252519A1	17.11.2005
		US7178532B2	20.02.2007
US6223753B1	01.05.2001	None	
CN1871971A	06.12.2006	EP1728450A2	06.12.2006
		JP2006334110A	14.12.2006
		US2006272665A1	07.12.2006
		KR20060125589A	06.12.2006
		EP1728450A3	26.12.2007
		CN200987445Y	12.12.2007
		RU2006118927A	20.12.2007

Form PCT/ISA/210 (patent family annex) (April 2007)

INTERNATIONAL SEARCH REPORT

International application No.

PCT/CN2008/070660

A. CLASSIFICATION OF SUBJECT MATTER

According to International Patent Classifications (IPC) or to both national classification and IPC

A45D2/36 (2006.01) i
A45D7/06 (2006.01) i
A45D20/12 (2006.01) n
H01H15/00 (2006.01) n

REFERENCES CITED IN THE DESCRIPTION

This list of references cited by the applicant is for the reader's convenience only. It does not form part of the European patent document. Even though great care has been taken in compiling the references, errors or omissions cannot be excluded and the EPO disclaims all liability in this regard.

Patent documents cited in the description

- CN ZL200520035229 [0002]