



(11) **EP 2 227 657 B1**

(12) **EUROPEAN PATENT SPECIFICATION**

(45) Date of publication and mention of the grant of the patent:
26.09.2018 Bulletin 2018/39

(51) Int Cl.:
F23J 3/06 ^(2006.01) **F23B 50/12** ^(2006.01)

(21) Application number: **08849919.9**

(86) International application number:
PCT/IT2008/000714

(22) Date of filing: **17.11.2008**

(87) International publication number:
WO 2009/063528 (22.05.2009 Gazette 2009/21)

(54) **BIO-MASS POWERED THERMAL BOILER WITH MAINTENANCE DRAWER FOR THE COMBUSTION CHAMBER AND THE SMOKE ASPIRATION FAN OF THE FLUE**

MIT BIOMASSE BEFEUERTER WÄRMEKESSEL MIT WARTUNGSSCHUBLADE FÜR DIE BRENNKAMMER UND DEN RAUCHGASLÜFTER DES ABZUGSKANALS

CHAUDIÈRE THERMIQUE ALIMENTÉE EN BIOMASSE AVEC TIROIR DE MAINTENANCE POUR LA CHAMBRE DE COMBUSTION ET LE VENTILATEUR D'ASPIRATION DE FUMÉE DU CONDUIT DE FUMÉE

(84) Designated Contracting States:
AT BE BG CH CY CZ DE DK EE ES FI FR GB GR HR HU IE IS IT LI LT LU LV MC MT NL NO PL PT RO SE SI SK TR

(30) Priority: **15.11.2007 IT CS20070048**

(43) Date of publication of application:
15.09.2010 Bulletin 2010/37

(73) Proprietor: **Ungaro SRL**
88040 S.Mango D'Aquino CZ (IT)

(72) Inventor: **UNGARO, Antonio**
88040 S. Mango D'Aquino CZ (IT)

(74) Representative: **Perrotta, Aldo et al**
Ing. Aldo Perrotta
Corso Umberto 81
88068 Soverato (IT)

(56) References cited:
EP-A1- 1 022 512 BE-A- 401 702
DE-C- 349 693 GB-A- 772 187
US-A- 168 168 US-A- 3 289 618
US-A- 4 677 965

EP 2 227 657 B1

Note: Within nine months of the publication of the mention of the grant of the European patent in the European Patent Bulletin, any person may give notice to the European Patent Office of opposition to that patent, in accordance with the Implementing Regulations. Notice of opposition shall not be deemed to have been filed until the opposition fee has been paid. (Art. 99(1) European Patent Convention).

Description

Technical field of the invention

[0001] The present invention regards the creation of a maintenance drawer for the combustion chamber and smoke aspiration fan of the flue of a bio-mass powered thermal boiler.

State of the Art

[0002] Biomass thermal boilers need constant maintenance in order to maintain a high level of efficiency.

[0003] During the combustion of the bio-masses ashes, creosote and dust are produced. The ashes, dust and the creosote must be continually gathered and removed in order to avoid the possibility of polluting the bio-mass powered thermal boiler, and thus decreasing their efficiency.

[0004] Bio-mass powered thermal boilers are normally fitted with a drawer for the ashes placed under the furnace, access to which is from the front, and by a drawer which collects the dust from the smoke, access to which is from the side.

[0005] Patent application WO-A-2006109346 describes a thermal boiler with a drawer below the smoke aspiration fan to collect the dust from the smoke. Said solution presents a series of inconveniences.

[0006] The cleaning of the ash drawer and of the dust drawer is carried out separately. The ash drawer is fitted in an easily accessible position. The *dust* drawer is fitted on the lateral part of the thermal boiler, which is generally difficult to access for non-specialized personnel. The user is therefore forced to ask for the intervention of the maintenance service to carry out the cleaning. The drawer is not easily inspected, in order to be able to eliminate the dust deposited in it.

[0007] EP1022512A1 discloses an oven with a drawer with two compartments that to be extracted needs to demount entire body of the oven. 2. EP1022512A1 discloses a bio-mass powered thermal boiler according to the preamble of claim 1. US3289618A and GB772187A show other drawers for ashes.

Description of the Invention.

[0008] The present invention proposes the creation of a drawer which allows the user, with a single operation, to keep the cleaning and maintenance of the furnace and aspiration fan under control, freeing the furnace from the ashes produced and the smoke aspiration fan free from the dust attracted by the fan itself.

[0009] The main object of the present invention is to overcome the difficulties and disadvantages present in the solutions on sale at present.

[0010] The present invention provides a bio-mass thermal boiler according to claim 1.

[0011] Another characteristic is given by the fact that

the compartment for collecting the ashes is of a parallel-epiped shape.

[0012] Other characteristics and advantages of the present invention will appear clear from the following description of a method of creating the present invention, given as a non-limiting example in the figures 1, 2 and 3.

Brief description of the figures.

10 [0013]

Figure 1 represents an axonometric view of a thermal boiler in which a drawer, object of the present invention, is placed for the maintenance of the combustion chamber and smoke aspiration fan of the flue of a bio-mass

Figure 2 represents a section of a thermal boiler in which a drawer, object of the present invention, is placed for the maintenance of the combustion chamber and the smoke aspiration fan of the flue of a bio-mass thermal boiler;

Figure 3 represents a view of the drawer, object of the present invention, for the maintenance of the combustion chamber and the smoke aspiration fan of the flue of a bio-mass thermal boiler.

Detailed description of an embodiment of the present invention

30 [0014] With reference to figure 1, which is an axonometric view of a bio-mass thermal boiler1, the door 2, placed in the front part, is visible.

[0015] In the front part, as can be seen in figure 2, behind the door 2, the drawer 20 is situated.

35 [0016] The drawer 20 is constituted of a closing and grasping element 21, to which an element formed of two compartments is attached, the compartment for ashes 22 followed by the compartment for dust 23. The drawer 20 is inserted from the front side of the thermal boiler 1, the compartment for ashes 22 is situated under the furnace 24 and the compartment for dust 23 is positioned under the smoke aspiration fan 25. The compartment 22 creates, with its side in contact with the compartment for dust 23, a perfect seal with the walls of the furnace.

45 [0017] In this way the ashes produced in the furnace 24 fall into the ash compartment 22 situated under the furnace 24, while the dust produced by the smoke from combustion is collected in the dust compartment 23, situated under the aspiration fan 25.

50 [0018] To carry out the cleaning and maintenance of the thermal boiler 1 of ashes and smoke dust it is thus necessary to pull out the drawer 20 frontally, grasping the closing and grasping element 21, empty the refuse eventually contained both in the compartment 22 and in the compartment 23 and return the drawer 20 to its place.

55 [0019] The shape of the ash drawer 22 can be of a parallelepiped form, while the shape of the dust compartment 23 can be cylindrical in order to better adhere to

the shape of the aspiration fan.

[0020] To always keep both the furnace 1 and the aspiration fan 25 clean it is sufficient to periodically repeat the above described cleaning and maintenance operation, without the necessity for complicated operations that necessitate complex dismantling and reassembling.

[0021] In this way both the furnace 1 and the aspiration fan 25 of the thermal boiler are kept clean and therefore the efficiency of the thermal boiler is always maintained at a high level.

[0022] The invention, it should be noted, is not limited to the representations given by the figures, but may be perfected and modified by those skilled in the Art, without, however, exceeding the limits of the appended claims.

[0023] The present invention permits numerous advantages and to overcome difficulties that could not be overcome with the systems on sale at present.

Claims

1. Bio-mass powered thermal boiler (1) comprising a furnace (24) situated in the combustion chamber, a flue, an aspiration fan (25) for aspirating smoke, and a maintenance drawer (20) for the combustion chamber and for the smoke aspiration fan of the flue, wherein the maintenance drawer (20) is inserted into the front part of the thermal boiler (1) and has two compartments, one compartment (22) situated under the furnace (24) to collect the ashes, the other compartment (23) situated under the aspiration fan (25) to collect the dust contained in the combustion smoke, the compartment for ashes being followed by the compartment for dust, **characterised by** the fact that the compartment for ashes (22) creates, with its side in contact with the compartment for dust (23), a perfect seal with the walls of the furnace (24).
2. Bio-mass powered thermal boiler (1) according to claim 1, **characterised by** the fact that the maintenance drawer (20) has frontally a closing and grasping element (21).
3. Bio-mass powered thermal boiler (1) according to claim 2, **characterised by** the fact that the compartment of the drawer for collecting the ashes (22) is parallelepiped in shape.
4. Bio-mass powered thermal boiler (1) according to claim 2 or 3, **characterised by** the fact that the compartment of the drawer for collecting dust (23) is cylindrical in shape.

Patentansprüche

1. Biomasse betriebener Wärmekessel (1) bestehend aus einem Ofen (24), der in der Brennkammer plat-

ziert ist, einem Kaminschacht, einem Absauglüfter (25), um Rauch abzusaugen, und einer Wartungslade (20) entfernt von der Brennkammer und entfernt vom Absauglüfter am Kaminschacht, wo die Wartungslade (20) im Frontteil des Heizkessels (1) eingebaut ist und aus zwei Kammern besteht, eine Kammer (22) unter dem Ofen angebracht (24), um die Asche aufzufangen, die andere Kammer (23) unter dem Absauglüfter (25) angebracht, um Staub aus dem Verbrennungsrauch aufzufangen, die Aschekammer wird von der Staubkammer gefolgt, **gekennzeichnet dadurch, dass** die Aschekammer (22) mit ihrer Seite, die die Staubkammer (23) berührt, mit den Ofenwänden (24) eine perfekte Verschlussnaht bildet.

2. Biomasse betriebener Wärmekessel (1) nach Anspruch 1, **gekennzeichnet dadurch, dass** die Wartungslade (20) einen frontalen Verschluss und Greifelement (21) besitzt.

3. Biomasse betriebener Wärmekessel (1) nach Anspruch 2, **gekennzeichnet dadurch, dass** die Aschekammer der Wartungslade (22) eine Parallelepipedform aufweist.

4. Biomasse betriebener Wärmekessel (1) nach Anspruch 1 und 2, **gekennzeichnet dadurch, dass** die Staubkammer der Wartungslade (22) eine zylindrische Form aufweist.

Revendications

1. Chaudière thermique (1) alimentée en biomasse comprenant un fourneau (24) situé dans la chambre de combustion, un conduit de cheminée, un ventilateur d'aspiration (25) pour aspirer la fumée et un tiroir de maintenance (20) pour la chambre de combustion et le ventilateur d'aspiration sur le conduit de cheminée, dans laquelle le tiroir de maintenance (20) est inséré sur la face avant de la chaudière thermique (1) et comporte deux compartiments, un compartiment (22) situé sous le fourneau (24) pour recueillir les cendres, l'autre compartiment (23) situé sous le ventilateur d'aspiration (25) pour recueillir la poussière contenue dans la fumée de combustion, le compartiment à cendres étant suivi par le compartiment à poussière, **caractérisée en ce que** le compartiment à cendres (22) crée, avec son côté en contact avec le compartiment à poussière (23), un parfait joint d'étanchéité avec les parois du fourneau (24).
2. Chaudière thermique (1) alimentée en biomasse selon la revendication 1, **caractérisée en ce que** le tiroir de maintenance (20) présente un élément de fermeture et de préhension (21) situé de manière frontale.

3. Chaudière thermique (1) alimentée en biomasse selon la revendication 2, **caractérisée en ce que** le compartiment (22) du tiroir de récolte des cendres est de forme parallélépipédique.

5

4. Chaudière thermique (1) alimentée en biomasse selon la revendication 2 ou 3, **caractérisée en ce que** le compartiment (23) du tiroir de collecte de poussière est de forme cylindrique.

10

15

20

25

30

35

40

45

50

55

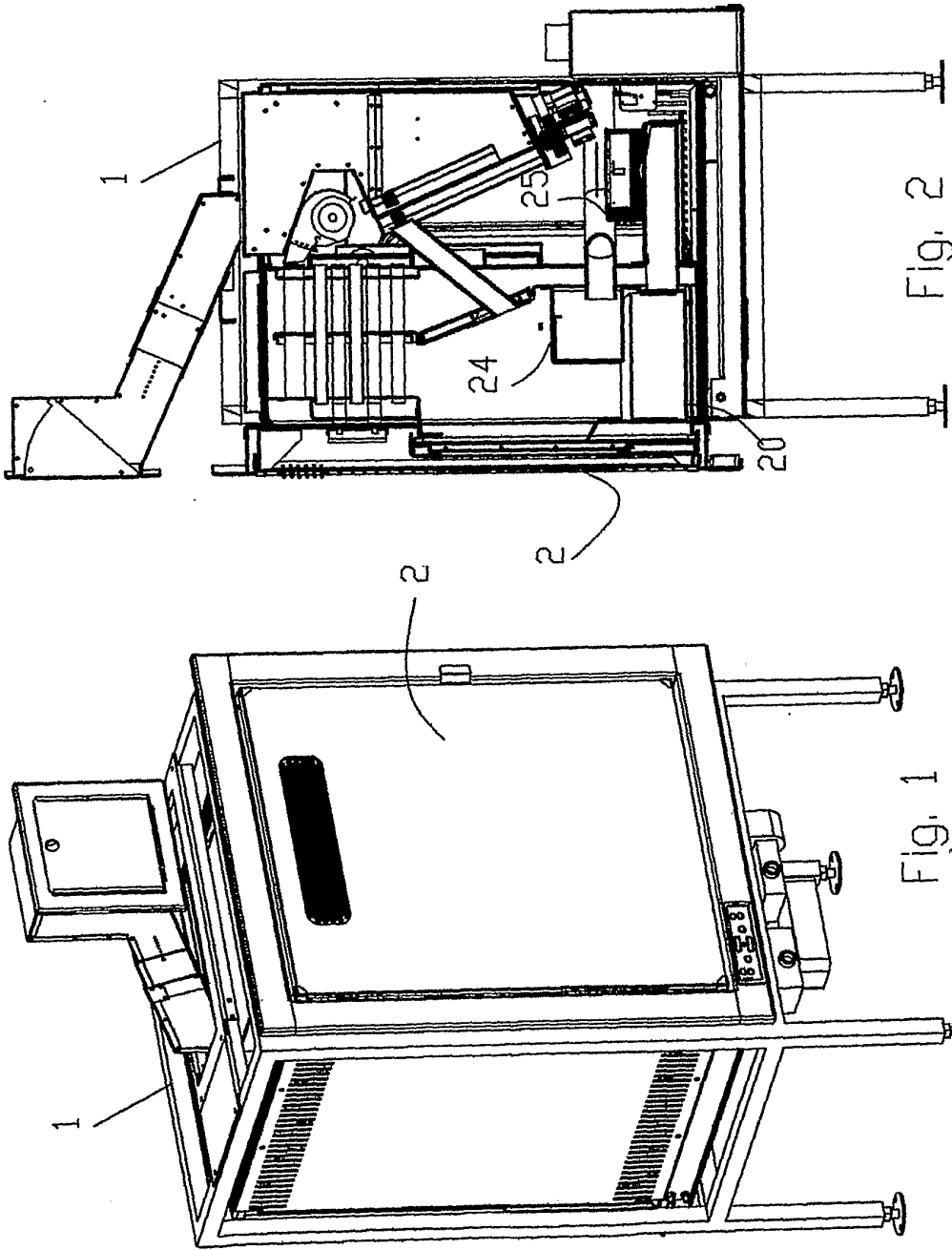

Fig. 2

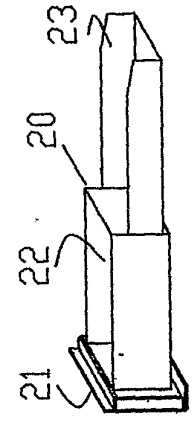

Fig. 3

REFERENCES CITED IN THE DESCRIPTION

This list of references cited by the applicant is for the reader's convenience only. It does not form part of the European patent document. Even though great care has been taken in compiling the references, errors or omissions cannot be excluded and the EPO disclaims all liability in this regard.

Patent documents cited in the description

- WO 2006109346 A [0005]
- EP 1022512 A1 [0007]
- US 3289618 A [0007]
- GB 772187 A [0007]