

(19)



(11)

EP 2 241 514 B1

(12)

EUROPEAN PATENT SPECIFICATION

(45) Date of publication and mention of the grant of the patent:
23.09.2015 Bulletin 2015/39

(51) Int Cl.:
B65D 43/02^(2006.01)

(21) Application number: **10159967.8**

(22) Date of filing: **15.04.2010**

(54) **Container with hermetic seal**

Behälter mit hermetischer Abdichtung

Conteneur avec fermeture hermétique

(84) Designated Contracting States:
**AT BE BG CH CY CZ DE DK EE ES FI FR GB GR
HR HU IE IS IT LI LT LU LV MC MK MT NL NO PL
PT RO SE SI SK SM TR**

(30) Priority: **15.04.2009 IT BO20090238**

(43) Date of publication of application:
20.10.2010 Bulletin 2010/42

(73) Proprietor: **F.Ceredi S.P.A.
40069 Zola Predosa (IT)**

(72) Inventor: **Ceredi, Gilberto
40069, ZOLA PREDOSA (IT)**

(74) Representative: **Bergadano, Mirko et al
Studio Torta S.p.A.
Via Viotti, 9
10121 Torino (IT)**

(56) References cited:
**DE-U1- 29 920 915 FR-A- 2 440 322
NL-A- 7 113 949**

EP 2 241 514 B1

Note: Within nine months of the publication of the mention of the grant of the European patent in the European Patent Bulletin, any person may give notice to the European Patent Office of opposition to that patent, in accordance with the Implementing Regulations. Notice of opposition shall not be deemed to have been filed until the opposition fee has been paid. (Art. 99(1) European Patent Convention).

Description

[0001] The present invention relates to a container with hermetic seal.

[0002] In particular, the present invention relates to a container with hermetic seal of the type comprising a bottom wall, a side wall and an upper opening giving access to the product, for example paint or varnish, inside the container. The container comprises a reinforced frame surrounding the opening and obtained by folding an upper edge of said opening; and a closing assembly of the opening comprising, in turn, a plug provided with an upper edge folded towards the outside and an adapter defined by an annular body presenting, at one end, a first annular cavity housing the folded upper edge of the plug.

[0003] Containers with hermetic seal of the type described above are widely used as the closing assembly can be press-fitted on the opening of the container, i.e. simply by applying a force to the closing assembly towards the opening; moreover, this type of coupling creates no particular problems and requires no particular precautions, for example to align the closing assembly with respect to the opening.

[0004] NL 7113949 discloses such a container and according to the preamble of appended claim 1.

[0005] It is important to note that the containers of the type described above can contain, for example, paint or varnish and, for many products, the container must be able to guarantee a perfect seal to prevent any undesirable leaking of the product. Besides being easy to assemble in order to limit the costs of production and ensuring good hermetic sealing properties, for this type of container there is an increasing need to guarantee the reliability of the seal even in the event of damage and tampering.

[0006] The object of the present invention is to provide a container with hermetic seal, which is easy and inexpensive to produce, overcomes the inconveniences of the prior art and in particular guarantees the perfect seal of the closing assembly.

[0007] According to the present invention there is provided a container according to that claimed in the appended claims.

[0008] The present invention will now be described with reference to the accompanying drawings, illustrating some non-limiting embodiments thereof, in which:

- figure 1 is a partial and cross-sectional view of a detail of a preferred embodiment of the container according to the present invention;
- figures 2 and 4 are partial and cross-sectional views of a first embodiment of a closing assembly of the container of figure 1;
- figures 3 and 5 are plan views of respective details of the closing assembly of figures 2 and 4;
- figures 6a to 6c show respective steps in sequence of the process for assembling the closing assembly of figures 2 to 5;

- figures 7a and 7b show respective steps of the process for removing the closing assembly of figures 2 to 5;
- figures 8a to 8c show respective steps in sequence of the process for assembling a second embodiment of the closing assembly;
- figures 9a and 9b show respective steps of the process for removing the closing assembly of figures 8a to 8c;
- figures 10a to 10c, 11a to 11c and 12a to 12c are cross-sectional views of respective alternative embodiments of respective details of the container of figure 1;
- figures 13a to 13d show respective steps in sequence of the process for assembling further embodiments of the closing assembly on the container of figure 1;
- figures 14a and 14b are cross-sectional views of respective alternative embodiments of the container of figure 1.

[0009] In figure 1, indicated as a whole by numeral 1 is a container made of metal, having a cylindrical side wall 2 open at the top. An upper opening 3 has a central axis (not illustrated) and is surrounded by a cylindrical collar 4, the upper edge 5 of which is folded towards the inside so as to form a reinforced frame 7 delimiting an annular cavity 6.

[0010] More in detail, the cylindrical collar 4 comprises a lower cylindrical connecting wall 8 and an intermediate cylindrical connecting wall 9 having an inside diameter that is greater than the inside diameter of the lower cylindrical connecting wall 8. The two lower 8 and intermediate 9 cylindrical connecting walls are joined by the interposition of a horizontal annular bearing wall 10. The cylindrical collar 4 also comprises an upper cylindrical connecting wall 11, an upper end of which is folded towards the inside to form the reinforced frame 7 and which has an inside diameter that is greater than the inside diameter of the intermediate cylindrical connecting wall 9, to which it is joined by means of an annular shoulder 12.

[0011] According to the embodiment illustrated in figure 2, the opening 3 is closed by means of a closing assembly 13 comprising a plastic adapter 14 and a metal plug 15. The plug 15 is substantially cap-shaped and has an upper annular edge 16 folded outwards.

[0012] The adapter 14 is defined by an annular body, which can be moulded directly onto the upper edge 16 of the plug 15 or, alternatively, can be made separately and then snap-fitted to the upper edge 16.

[0013] The adapter 14 comprises an annular connecting portion 17 and a tear-off portion 18. The connecting portion 17 is provided at one end facing towards the opening 3 with an annular cavity 19. The annular cavity 19 is defined by an internal side wall 20, a section 21 of upper wall and an external side wall 22. The external side wall 22 comprises an entrance portion 23 increasing in thickness towards the section 21 of upper wall, and an internal

portion 24 that is engaged by the upper edge 16 and is joined to the entrance portion 23 by means of an annular shoulder 25 defining a tooth against which the upper edge 16 rests.

[0014] The conical side surface 26 of the entrance portion 23 defines in turn a guiding element for the upper edge 16 while the adapter 14 is fitted on the plug 15. The adapter 14 also comprises a lower annular sealing appendix 27 which protrudes downwards from the entrance portion 23 and is suitable to improve the seal of the closing assembly 13 as described more fully below.

[0015] Thus as a whole, an external surface 28 of the connecting portion 17 consists of an initial conical section 29 in correspondence with the lower appendix 27 and the entrance portion 23 and a cylindrical section 30 in correspondence with the internal portion 24 of the external side wall 22.

[0016] The external side wall 22 is joined to the annular tear-off portion 18 which has a substantially trapezoidal cross-section and is provided with a conical side surface 31. A grasping device 32 is connected to the tear-off portion 18 and, according to the embodiment illustrated in figure 3, comprises a flap 33 connected in correspondence to two V-shaped weakening cuts, indicated respectively by numbers 34 and 35, to the tear-off portion 18, so as to protrude radially towards the inside of the adapter 14.

[0017] According to the embodiment illustrated in figure 4, even when the tear-off portion 18 is removed, the connecting portion 17 is joined to a grasping device 36, which is suitable to facilitate the removal of the plug 15 so that the user can use the contents of the container 1. In particular, according to the embodiment illustrated in figure 5, the grasping device 36 comprises a handle 37, which is connected to the internal side wall 20 and to the upper wall 21 of the connecting portion 17 so as to protrude radially towards the inside of the plug 15. The grasping device 36 may comprise handles of other shapes or different elements, the number and arrangement of which generally depend on the size of the plug 15. In the case of a relatively small plug 15 the adapter 14 is provided with a single handle 37 arranged diametrically opposite the grasping device 32 so that they do not interfere with one another. In the case of a larger plug 15, there may be two handles 37 arranged diametrically and orthogonally with respect to the grasping device 32 so as not to interfere with one another.

[0018] Figures 6a to 6c show respective steps in sequence of the process for assembling the closing assembly 13 on the container 1.

[0019] In the case of an adapter 14 produced separately and not moulded directly onto the plug 15, in a first step (which is not illustrated) of the assembly process of the closing assembly 13, the adapter 14 is snap-fitted onto the plug 15. The conical side surface 26 of the entrance portion 23 defines a guide that facilitates the passage of the upper edge 16 of the plug 15 until the upper edge 16 engages the annular cavity 19 and is held in this

position blocked by the annular shoulder 25.

[0020] Next, after fitting the adapter 14 on the plug 15, the closing assembly 13 is mounted on the reinforced frame 7 by means of a pusher element which first aligns the closing assembly 13 so that the opening 3 and the axis of the closing assembly 13 are coaxial (this step in the assembly process is illustrated in figure 6a).

[0021] Next, the closing assembly 13 is inserted into the opening 3 by means of pressure applied directly to a central part of the plug 15 or to the internal side wall 20 and/or to the upper wall 21 of the connecting portion 17. During this insertion step, the tear-off portion 18 is forced to rest against the upper edge 5 of the cylindrical collar 4 which delimits the opening 3 and thus tends to bend slightly and move in an anticlockwise direction as illustrated more clearly in figure 6b.

[0022] The moment an end portion 38 of the tear-off portion 18 is snap-fitted inside the annular cavity 6, the closing assembly 13 is completely inserted and blocked on the opening 3. In this way it is impossible to remove the plug 15 without first removing the tear-off portion 18.

[0023] In the position illustrated in figure 6c, in which the closing assembly 13 is completely inserted, the lower appendix 27 is partially deformed so that the initial conical section 29 comes into contact with the annular bearing wall 10 to guarantee a seal on said annular bearing wall 10.

[0024] The cylindrical section 30 of the external side surface 28 comes into contact with the internal surface of the intermediate cylindrical connecting wall 9 to improve the tightness and hermetically seal the container 1. Moreover, a lower portion 39 of a side wall 40 of the plug 15, which is not involved in the coupling with the adapter 14, comes into contact with the internal surface of the lower cylindrical connecting wall 8 to further improve the seal and prevent any product from leaking out of the container.

[0025] Once the closing assembly 13 is completely inserted inside the opening 3, when the user wishes to open the container for the first time he must perform a series of mandatory operations, making unauthorised access to the container 1 practically impossible.

[0026] As illustrated in more detail in figures 7a and 7b, the first time the container 1 is opened the user must grasp the flap 33 of the grasping device 32 and pull to tear the tear-off portion 18 of the adapter 14 in correspondence with the weakening V-shaped cut 34. By continuing to pull the flap 33, the tear-off portion 18 comes away from the connecting portion 17 in correspondence with the annular V-shaped weakening cut 35. The tear-off portion 18 is thus completely removed, so that its end portion 38 no longer engages the annular cavity 6 and the plug 15 is no longer blocked on the opening 3, while the connecting portion 17 of the adapter 14 remains integrally attached to the plug 15 (as illustrated in figure 7a).

[0027] At this stage, as illustrated in more detail in figure 7b, the user can take hold of the grasping device 36 connected to the connecting portion 17 and raise the clos-

ing assembly 13 in order to remove it and gain access to the contents of the container 1.

[0028] According to an alternative embodiment illustrated in figures 8 and 9, the tear-off portion 18 of the adapter 14 comprises a removable portion 41, which has a substantially trapezoidal cross-section and is connected at one side to the connecting portion 17 in correspondence with the V-shaped weakening cut 35. At the other side, the tear-off portion 41 is connected to a fixing edge 42 so as to define a weakening cut 43. The fixing edge 42 has a rounded shape that substantially reproduces in negative the profile of the upper edge 5 of the cylindrical collar 4 folded towards the inside, so that the fixing edge 42 completely fills the annular cavity 6. The grasping device 32 is connected to the tear-off portion 41 and comprises the flap 33 that protrudes radially towards the inside of the adapter 14.

[0029] In this case, the closing assembly 13 is inserted into the opening 3 as described previously, i.e. during the insertion of the closing assembly 13 the fixing edge 42 snaps into place to engage the annular cavity 6. In this way, the tear-off portion 18 is blocked inside the annular cavity 6 with its fixing edge 42, blocking the plug 15 on the opening 3 so that it cannot be removed except by first removing the tear-off portion 18. At this point another step can be performed in which the upper edge 5 of the cylindrical collar 4 is partially folded so as to firmly block the fixing edge 42.

[0030] Also in this case, all the steps of the assembly process of the container 1 are performed using an automatic insertion device that is suitable in use to join the closing assembly 13 to the cylindrical collar 4. In this second embodiment, the automatic device is fitted with an additional element that, once the fixing edge 42 has been inserted into the annular cavity 6, also partially folds said edge 5 in order to guarantee the formation of a mechanical and hermetic seal for the container 1.

[0031] According to this alternative embodiment, when the user wishes to open the container 1 for the first time he must perform a series of mandatory steps, making unauthorised access to the container 1 practically impossible. To open the container for the first time, the user must take hold of the flap 33 of the grasping device 32 and pull to tear the tear-off portion 18 of the adapter 14 in correspondence with the V-shaped weakening cut 34. When the user continues to pull the flap 33, the tear-off portion 41 comes away from the connecting portion 17, in correspondence with the V-shaped weakening cut 35 and, in correspondence with the cut 43, the tear-off portion 41 comes away from the fixing edge 42, which remains blocked in the annular cavity 6.

[0032] The tear-off portion 41 is thus completely removed, while the fixing edge 42 remains blocked inside the annular cavity 6 and the connecting portion 17 of the adapter 14 remains integrally attached to the plug 15. The user can thus take hold of the grasping device 36 connected to the connecting portion 17 and raise the closing assembly 13 to remove it and gain access to the con-

tents of the container 1. Note that the fixing edge 42 does not obstruct the removal of the plug 15 in that it has a diameter greater than that of the plug 15 and does not interfere with said plug 15 during its removal.

[0033] It is apparent that the cylindrical collar 4 of the container 1 could alternatively have all the other geometric configurations illustrated in the figures from 11a to 11c.

[0034] The embodiments of the cylindrical collar 4 illustrated in figures 11a to 11c are identical to the embodiment illustrated in figures 1 to 9 from which they differ in that, in these embodiments, the portion of the side wall 2 of the container 1 arranged beneath the lower cylindrical connecting wall 8 is not cylindrical, but has a different shape and may, for instance, be tapered, conical or ribbed.

[0035] According to the embodiment illustrated in figures 12a to 12c, the upper connecting wall 11 is not cylindrical but conical, but this does not undermine the seal and reliability of the container 1.

[0036] Moreover, it is apparent that the upper edge 5 of the cylindrical collar 4 may selectively have all the alternative geometric configurations illustrated in the figures from 10a to 10c in which the upper edge 5 is folded towards the inside of the opening 3 and is geometrically configured so as not to undermine the seal and reliability of the container 1.

[0037] According to a further embodiment illustrated in figures 13a to 13d, the sealing function that was guaranteed by the lower appendix 27 is, in this case, guaranteed by an elastic connecting gasket 44 interposed between the annular bearing wall 10 and the upper edge 16 of the plug 15.

[0038] According to the alternative embodiment illustrated in figures 14a and 14b, the container 1 comprises a cup-shaped element 45, closed by a cover 46, which is provided with the opening 3 and is connected to the cup-shaped element 45 by coupling means. The opening 3 is surrounded by the cylindrical collar 4, the upper edge 5 of which is folded towards the inside of the opening 3, and which is closed by means of a closing assembly 13.

[0039] It is important to note that the container 1 illustrated in figures 1 to 13 has numerous advantages, in that it achieves a stable and hermetic seal between the closing assembly 13 and the cylindrical collar 4 while at the same time guaranteeing the strength and stability of said container 1, making unauthorised access impossible while making it easy for the user of the container 1 to have access to its contents.

Claims

1. Container (1) comprising an opening (3); a reinforced frame (7) surrounding the opening (3) and obtained by folding a first upper edge (5) of the opening (3); a closing assembly (13) of the opening (3) compris-

- ing, in turn, a plug (15) provided with a second upper edge (16) folded towards the outside; and an adapter (14) defined by an annular body presenting, at one end, a first annular cavity (19) housing the second folded upper edge (16);
 the container **being characterised in that** the upper edge (4) is folded towards the inside of the opening (3) and the adapter (14) comprises a first portion (17), provided with the annular cavity (19), and a second portion (18), connected to the first portion (17); the closing assembly (13) is inserted inside the opening (3) so that the second portion (18) of the adapter (14) is housed in the reinforced frame (7) in order to block the closing assembly (13) on the opening (3).
2. Container according to claim 1, wherein the second portion (18) comprises a first end, which is connected to the first portion (17), and a second end (38), which is housed in the reinforced frame (7) and is connected to a grasping device (32) in order to allow the removal of the second portion (18) when the container (1) is used for the first time.
 3. Container according to claim 2, wherein the grasping device (32) comprises at least one graspable flap (33) which protrudes radially towards the inside of the adapter (14) and is connected to the second portion (18) in correspondence with a pair of weakening cuts (34, 35) to allow the removal of the second portion (18).
 4. Container according to claim 1, wherein the second portion (18) comprises a first part (41) connected to the first portion (17) and a second part (42) suitable to be fixed in the reinforced frame (7); the first part (41) is connected to a grasping device (32) in order to allow the removal of said first part (41) when the container (1) is used for the first time.
 5. Container according to claim 4, wherein the second part (42) presents a rounded shape which completely fills an annular cavity (6) defined by the first upper edge (5) folded towards the inside of the opening (3).
 6. Container according to claim 4 or 5, wherein the grasping device (32) comprises at least one graspable flap (33) which protrudes radially towards the inside of the adapter (14) and is connected to the first part (41) in correspondence with a plurality of weakening cuts (34, 35, 43) in order to completely separate the first part (41) from the first portion (17) and from the second fixing part (42) when the container (1) is used for the first time and remove it from the opening (3).
 7. Container according to one of the claims from 2 to 6, wherein the first connection portion (17) is connected to a grasping device (36) which is suitable to remove the plug (15).
 8. Container according to claim 7, wherein the grasping device (36) comprises at least one handle (37) which protrudes radially towards the inside of the plug (15) and is arranged in such a manner as not to interfere with the grasping device (32).
 9. Container according to one of the previous claims, wherein the adapter (14) further comprises a seal element (27; 44) which is suitable to improve the seal of the closing assembly (13) on a collar (4) of the container (1).
 10. Container according to claim 9, wherein the seal element (27) comprises an annular appendix (27) which protrudes downwards from the first portion (17) to be arranged in contact with an annular bearing wall (10) of the collar (4).
 11. Container according to claim 9, wherein the seal element (44) comprises an annular elastic gasket (44) interposed between an annular bearing wall (10) of the collar (4) and the second upper edge (16) folded towards the outside of the plug (15).

Patentansprüche

1. Behälter, umfassend:

eine Öffnung (3);
 einen verstärkten Rahmen (7), der die Öffnung (3) umgibt und durch Falzen einer ersten Oberkante (5) der Öffnung (3) erhalten ist;
 eine Schließanordnung (13) der Öffnung (3), die wiederum einen Stopfen (15), welcher mit einer zweiten Oberkante (16) versehen ist, die zur Außenseite hin gefalzt ist, und einen Adapter (14) umfasst, der durch einen ringförmigen Körper definiert ist, welcher an einem Ende einen ersten ringförmigen Hohlraum (19) aufweist, der die zweite gefalzte Oberkante (16) einfasst;
 wobei der Behälter **dadurch gekennzeichnet ist, dass** die Oberkante (4) zur Innenseite der Öffnung (3) hin gefalzt ist und der Adapter (14) einen ersten Abschnitt (17), der mit einem ringförmigen Hohlraum (19) versehen ist, und einen zweiten Abschnitt (18) umfasst, der mit dem ersten Abschnitt (17) verbunden ist; wobei die Schließanordnung (13) derart innerhalb der Öffnung (3) eingeführt ist, dass der zweite Abschnitt (18) des Adapters (14) zum Blockieren der Schließanordnung (13) in der Öffnung (3) im verstärkten Rahmen (7) eingefasst ist.

2. Behälter nach Anspruch 1, wobei der zweite Ab-

- schnitt (18) ein erstes Ende, das mit dem ersten Abschnitt (17) verbunden ist, und ein zweites Ende (38) umfasst, das im verstärkten Rahmen (7) eingefasst ist und zum Ermöglichen der Entfernung des zweiten Abschnitts (18), wenn der Behälter (1) zum ersten Mal benutzt wird, mit einer Greifvorrichtung (32) verbunden ist.
3. Behälter nach Anspruch 2, wobei die Greifvorrichtung (32) zumindest eine greifbare Klappe (33) umfasst, die radial zur Innenseite des Adapters (14) hin vorsteht und mit dem zweiten Abschnitt (18) in Entsprechung zu einem Paar Schwächungsschnitte (34, 35) zum Ermöglichen der Entfernung des zweiten Abschnitts (18) verbunden ist.
4. Behälter nach Anspruch 1, wobei der zweite Abschnitt (18) ein erstes Teil (41), das mit dem ersten Abschnitt (17) verbunden ist, und ein zweites Teil (42) umfasst, das dazu geeignet ist, im verstärkten Rahmen (7) befestigt zu sein; wobei das erste Teil (41) zum Ermöglichen der Entfernung des ersten Teils (41), wenn der Behälter (1) zum ersten Mal benutzt wird, mit einer Greifvorrichtung (32) verbunden ist.
5. Behälter nach Anspruch 4, wobei das zweite Teil (42) eine abgerundete Form aufweist, die einen ringförmigen Hohlraum (6) vollständig ausfüllt, welcher durch die erste Oberkante (5) definiert ist, die zur Innenseite der Öffnung (3) hin gefalzt ist.
6. Behälter nach einem der Ansprüche 4 oder 5, wobei die Greifvorrichtung (32) zumindest eine greifbare Klappe (33) umfasst, die radial zur Innenseite des Adapters (14) vorsteht und mit dem ersten Teil (41) in Entsprechung zu mehreren Schwächungsschnitten (34, 35, 43) zum vollständigen Trennen des ersten Teils (41) vom ersten Abschnitt (17) und vom zweiten Befestigungsteil (42), wenn der Behälter (1) zum ersten Mal benutzt wird, und zum Entfernen desselben von der Öffnung (3) verbunden ist.
7. Behälter nach einem der Ansprüche 2 bis 6, wobei der erste Verbindungsabschnitt (17) mit einer Greifvorrichtung (36) verbunden ist, die zum Entfernen des Stopfens (15) geeignet ist.
8. Behälter nach Anspruch 7, wobei die Greifvorrichtung (36) zumindest einen Griff (37) umfasst, der radial zur Innenseite des Stopfens (15) hin vorsteht und derart angeordnet ist, dass er nicht störend auf die Greifvorrichtung (32) einwirkt.
9. Behälter nach einem der vorhergehenden Ansprüche, wobei der Adapter (14) ferner ein Abdichtungselement (27; 44) umfasst, das zum Verbessern der Abdichtung der Schließanordnung (13) an einem

Bund (4) des Behälters (1) geeignet ist.

10. Behälter nach Anspruch 8, wobei das Abdichtungselement (27) einen ringförmigen Ansatz (27) umfasst, der vom ersten Abschnitt (17) zur Anordnung in Kontakt mit einer ringförmigen Lagerwand (10) des Bunds (4) nach unten vorsteht.
11. Behälter nach Anspruch 9, wobei das Abdichtungselement (44) eine ringförmige elastische Dichtung (44) umfasst, die zwischen einer ringförmigen Lagerwand (10) des Bunds (4) und der zweiten Oberkante (16), welche zur Außenseite des Stopfens (15) hin gefalzt ist, eingeschoben ist.

Revendications

1. Récipient (1) comprenant une ouverture (3) ; un cadre renforcé (7) entourant l'ouverture (3) et obtenu par pliage d'un premier bord supérieur (5) de l'ouverture (3) ; un ensemble de fermeture (13) de l'ouverture (3) comprenant, à son tour, un bouchon (15) muni d'un deuxième second bord supérieur (16) plié vers l'extérieur ; et un adaptateur (14) défini par un corps annulaire présentant, à une extrémité, une première cavité annulaire (19) logeant le second bord supérieur (16) plié ; le récipient étant **caractérisé en ce que** le bord supérieur (4) est plié vers l'intérieur de l'ouverture (3) et l'adaptateur (14) comprend une première partie (17), munie de la cavité annulaire (19), et une seconde partie (18), reliée à la première partie (17) ; l'ensemble de fermeture (13) est inséré à l'intérieur de l'ouverture (3) de sorte que la seconde partie (18) de l'adaptateur (14) est logée dans le cadre renforcé (7) afin de bloquer l'ensemble de fermeture (13) sur l'ouverture (3).
2. Récipient selon la revendication 1, dans lequel la seconde partie (18) comprend une première extrémité qui est reliée à la première partie (17), et une seconde extrémité (38), qui est logée dans le cadre renforcé (7) et qui est reliée à un dispositif de préhension (32) afin de permettre le retrait de la seconde partie (18) lorsque le récipient (1) est utilisé pour la première fois.
3. Récipient selon la revendication 2, dans lequel le dispositif de préhension (32) comprend au moins un rabat préhensible (33) qui fait saillie radialement vers l'intérieur de l'adaptateur (14) et qui est relié à la seconde partie (18) en correspondance d'une paire de découpes (34, 35) de moindre résistance mécanique pour permettre le retrait de la seconde partie (18).

4. Récipient selon la revendication 1, dans lequel la seconde partie (18) comprend une première pièce (41) reliée à la première partie (17) et une seconde pièce (42) adaptée pour être fixée dans le cadre renforcé (7) ; la première pièce (41) est relié à un dispositif de préhension (32) afin de permettre le retrait de ladite première pièce (41) lorsque le récipient (1) est utilisé pour la première fois. 5
5. Récipient selon la revendication 4, dans lequel la seconde pièce (42) présente une forme arrondie qui remplit complètement une cavité annulaire (6) définie par le premier bord supérieur (5) replié vers l'intérieur de l'ouverture (3). 10
6. Récipient selon la revendication 4 ou 5, dans lequel le dispositif de préhension (32) comprend au moins un rabat préhensible (33) qui fait saillie radialement vers l'intérieur de l'adaptateur (14) et qui est relié à la première pièce (41) en correspondance d'une pluralité de découpes (34, 35, 43) de moindre résistance mécanique afin de séparer complètement la première pièce (41) de la première partie (17) et de la seconde pièce de fixation (42) lorsque le récipient (1) est utilisé pour la première fois et de la retirer de l'ouverture (3). 15 20 25
7. Récipient selon l'une des revendications 2 à 6, dans lequel la première partie de connexion (17) est reliée à un dispositif de préhension (36) qui est apte à retirer le bouchon (15). 30
8. Récipient selon la revendication 7, dans lequel le dispositif de préhension (36) comprend au moins une poignée (37) qui fait saillie radialement vers l'intérieur du bouchon (15) et qui est disposée de manière à ne pas interférer avec le dispositif de préhension (32). 35
9. Récipient selon l'une des revendications précédentes, dans lequel l'adaptateur (14) comprend en outre un élément d'étanchéité (27 ; 44) qui est approprié pour améliorer l'étanchéité de l'ensemble de fermeture (13) sur une collerette (4) du récipient (1). 40 45
10. Conteneur selon la revendication 9, dans lequel l'élément d'étanchéité (27) comporte un appendice annulaire (27) qui fait saillie vers le bas depuis la première partie (17) pour venir en contact avec une paroi de support annulaire (10) de la collerette (4). 50
11. Conteneur selon la revendication 9, dans lequel l'élément d'étanchéité (44) comprend un joint d'étanchéité élastique annulaire (44) interposé entre une paroi de support annulaire (10) de la collerette (4) et le second bord supérieur (16) plié vers l'extérieur du bouchon (15). 55

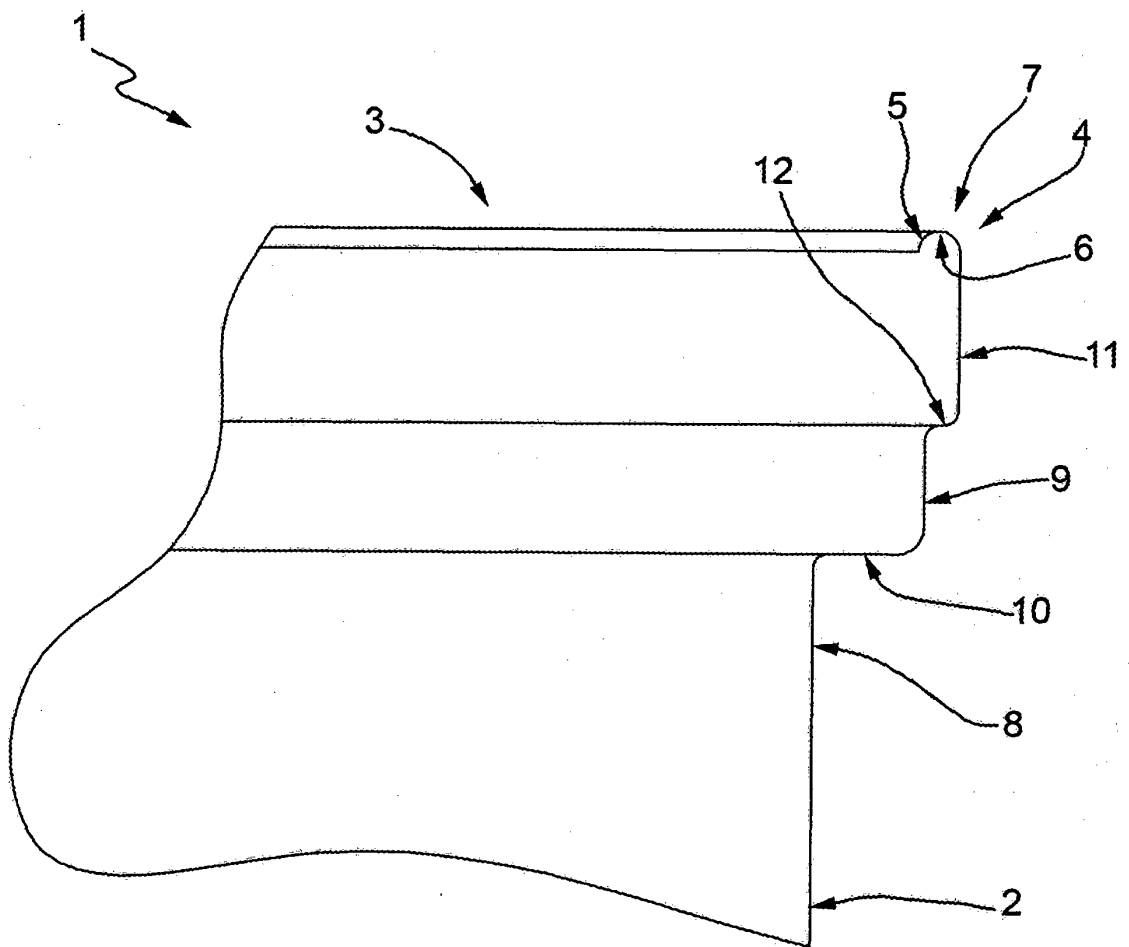
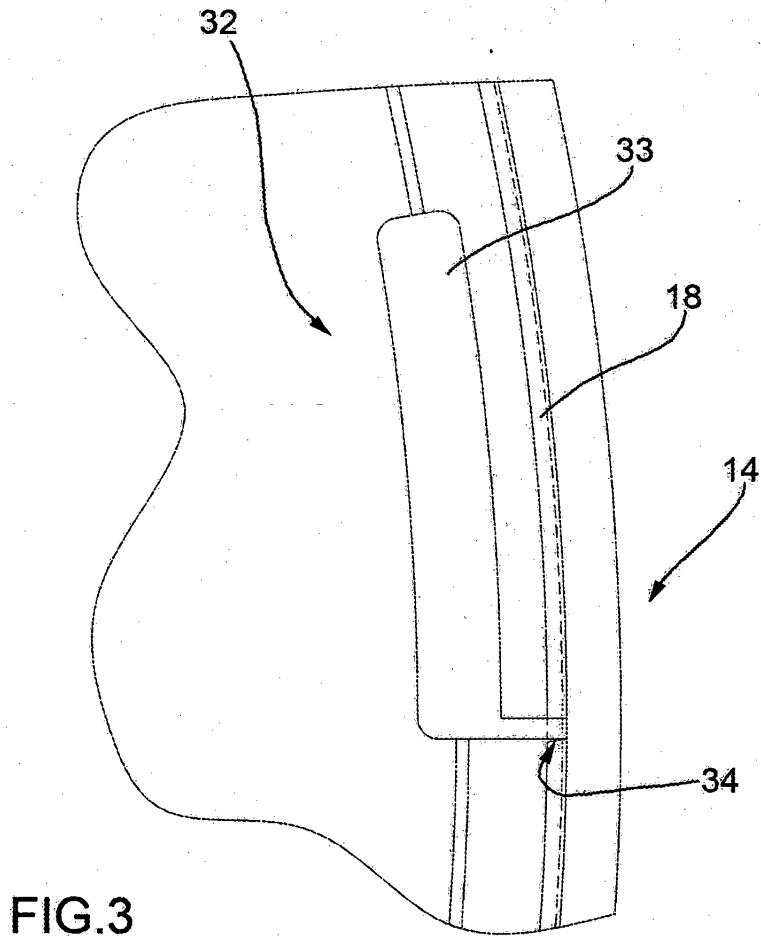
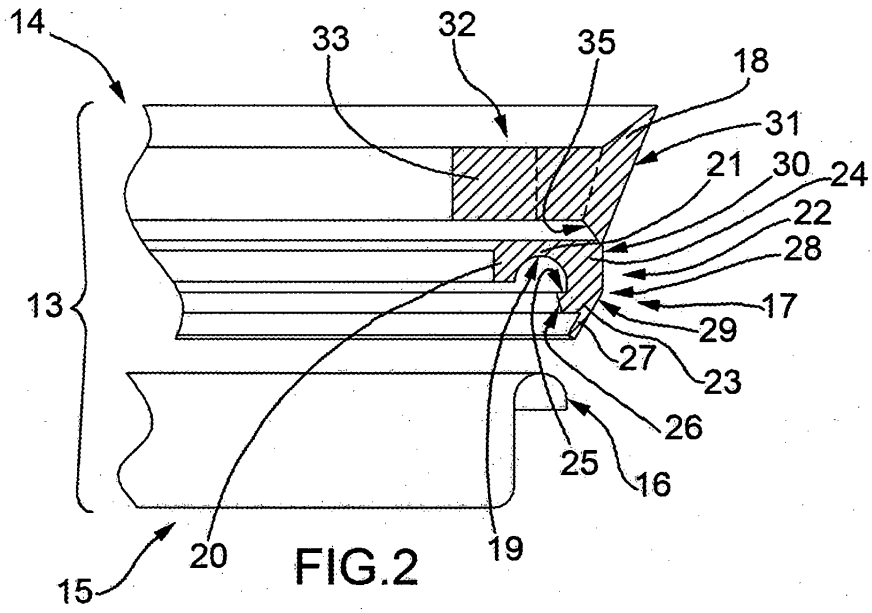
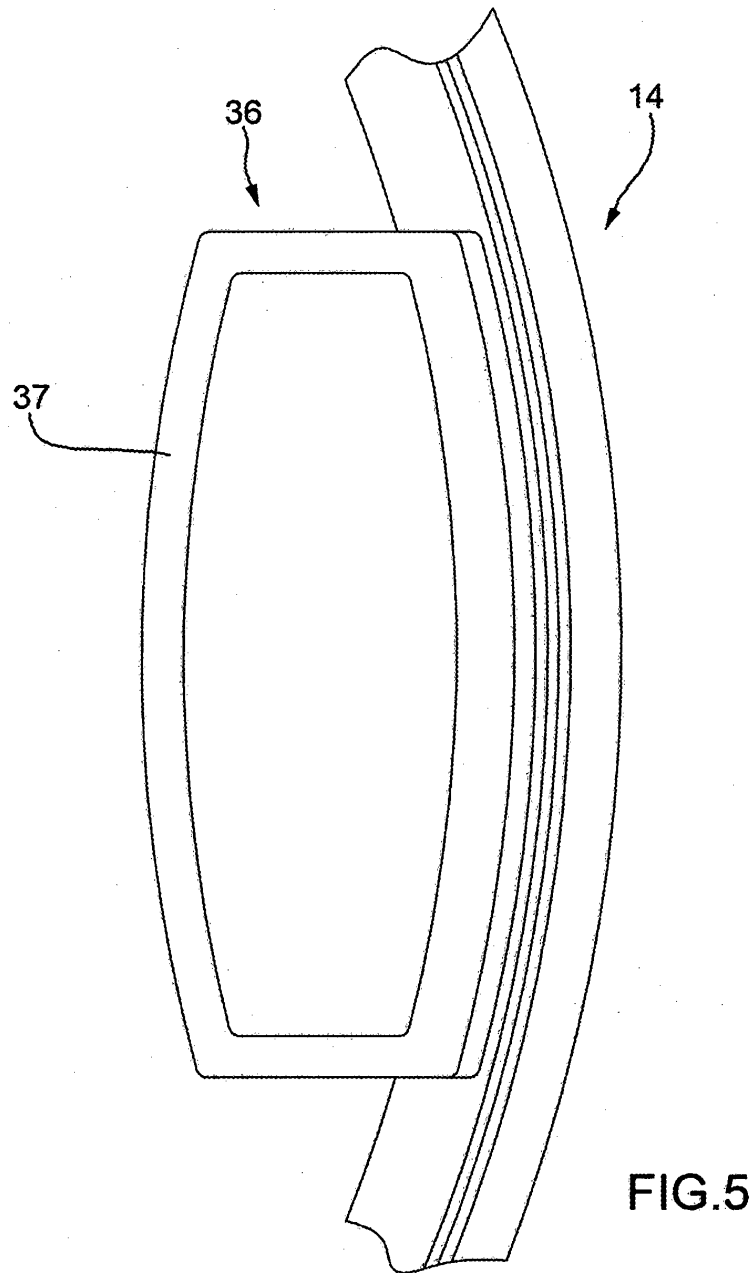
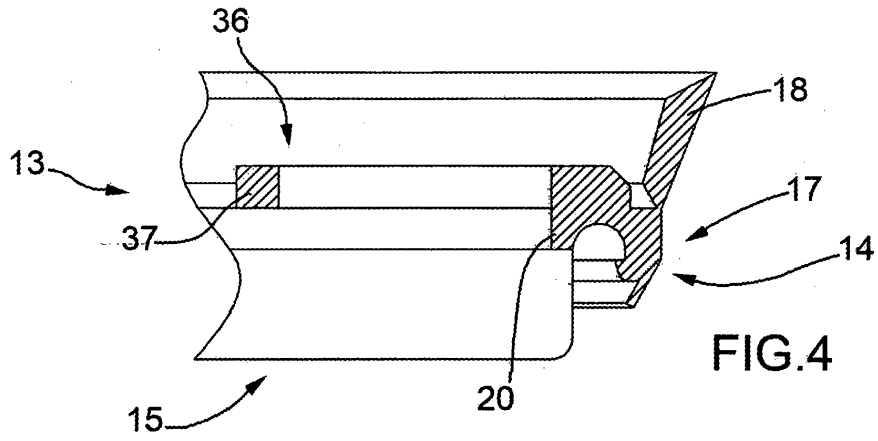

FIG.1





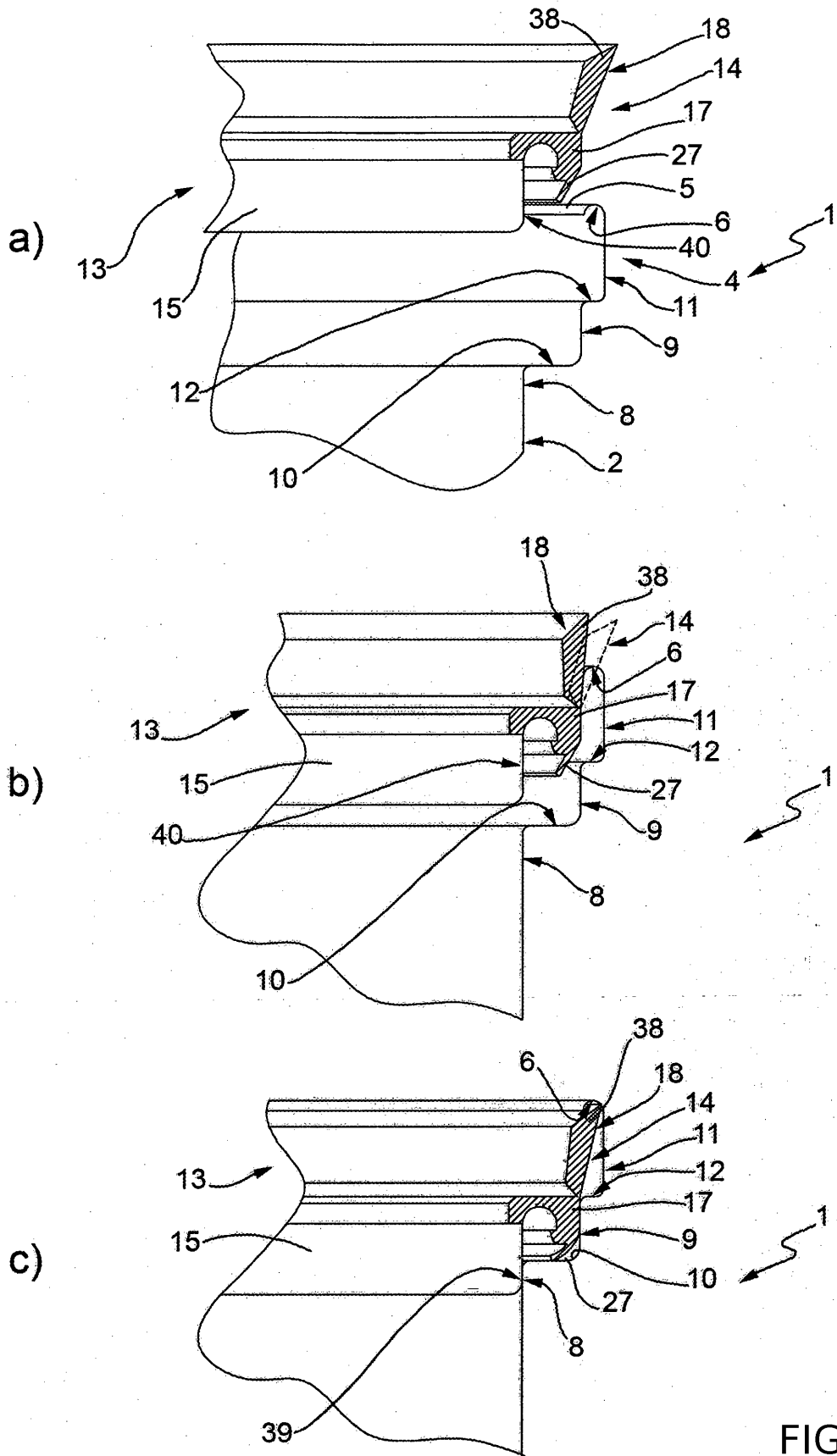

FIG. 6

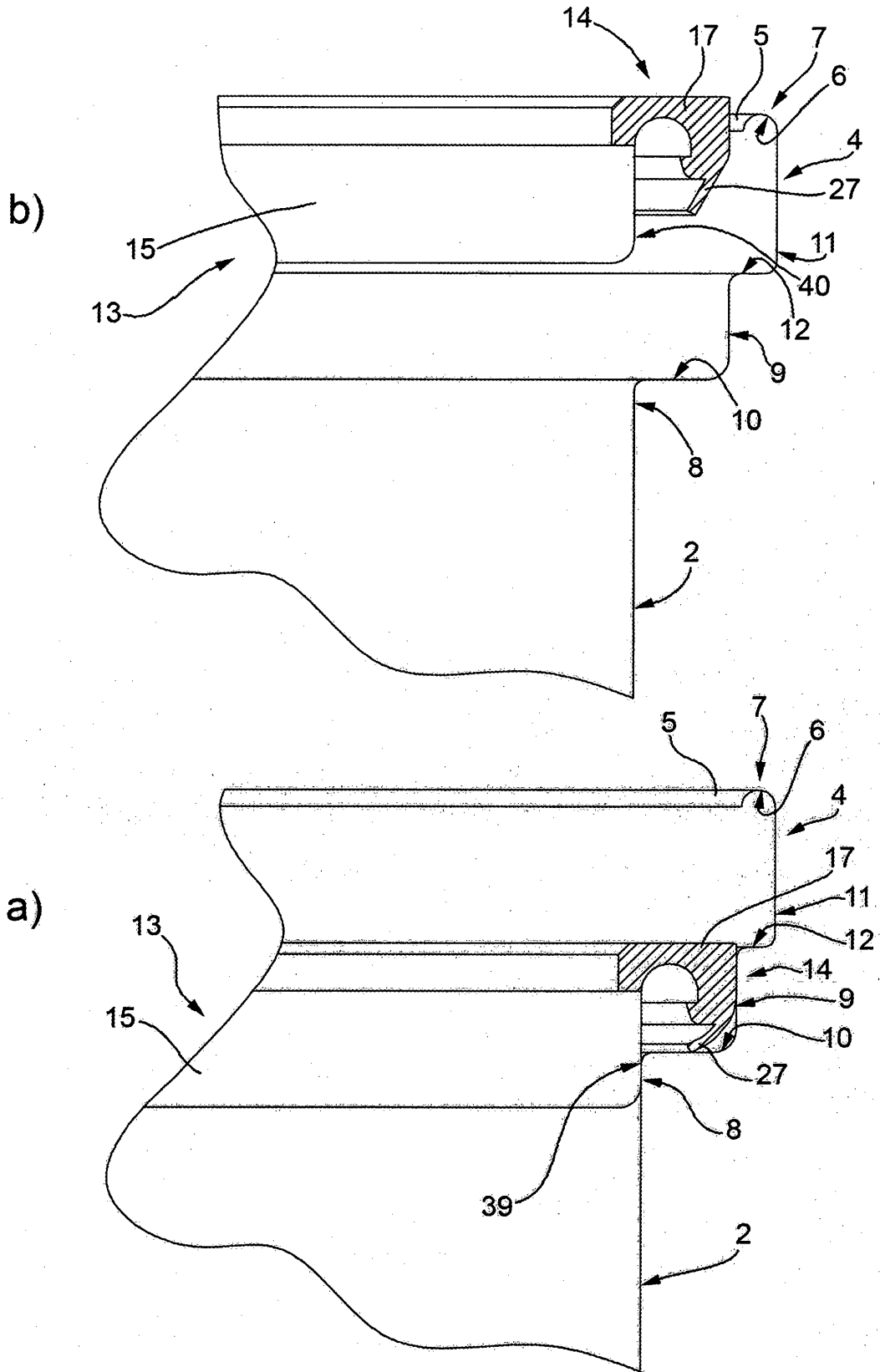

FIG.7

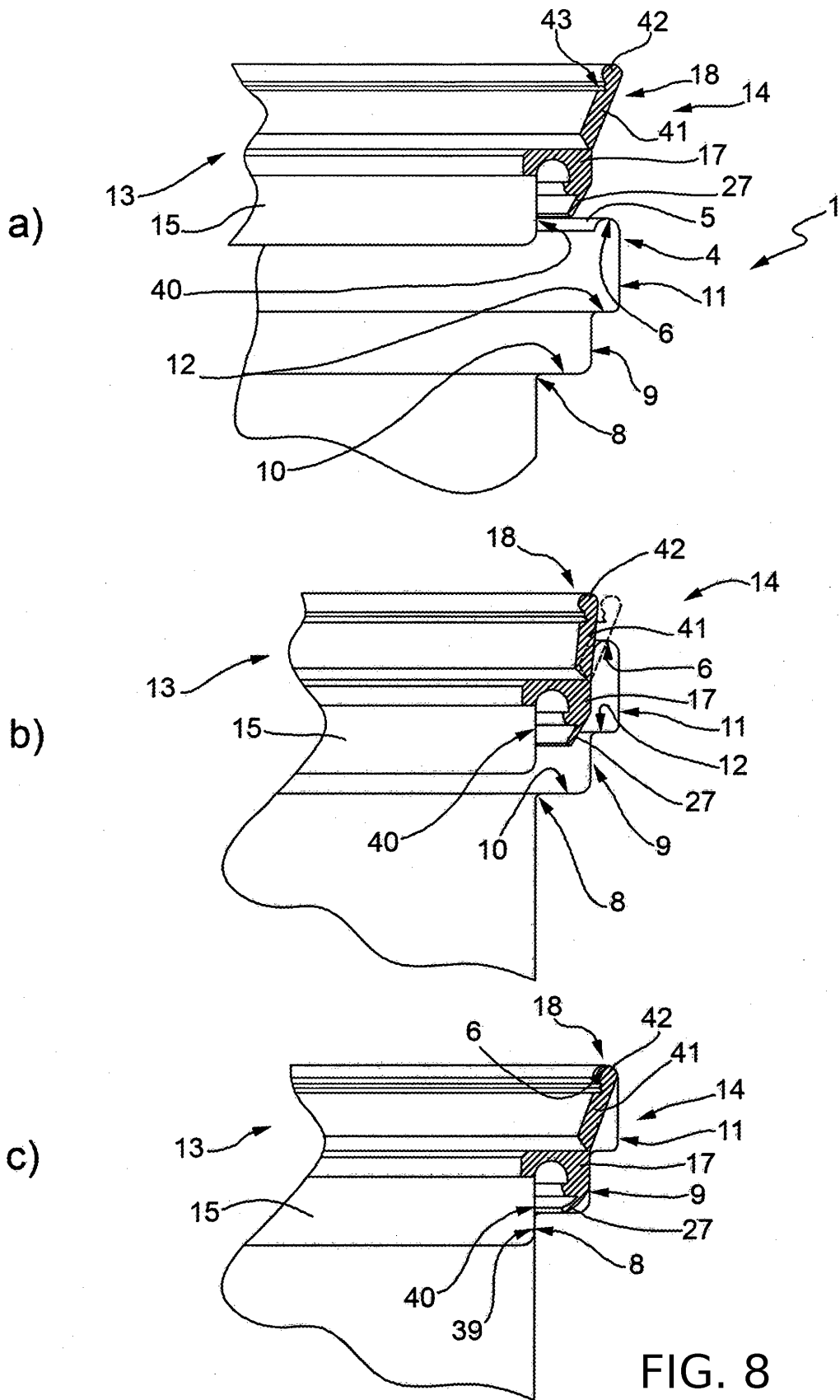

FIG. 8

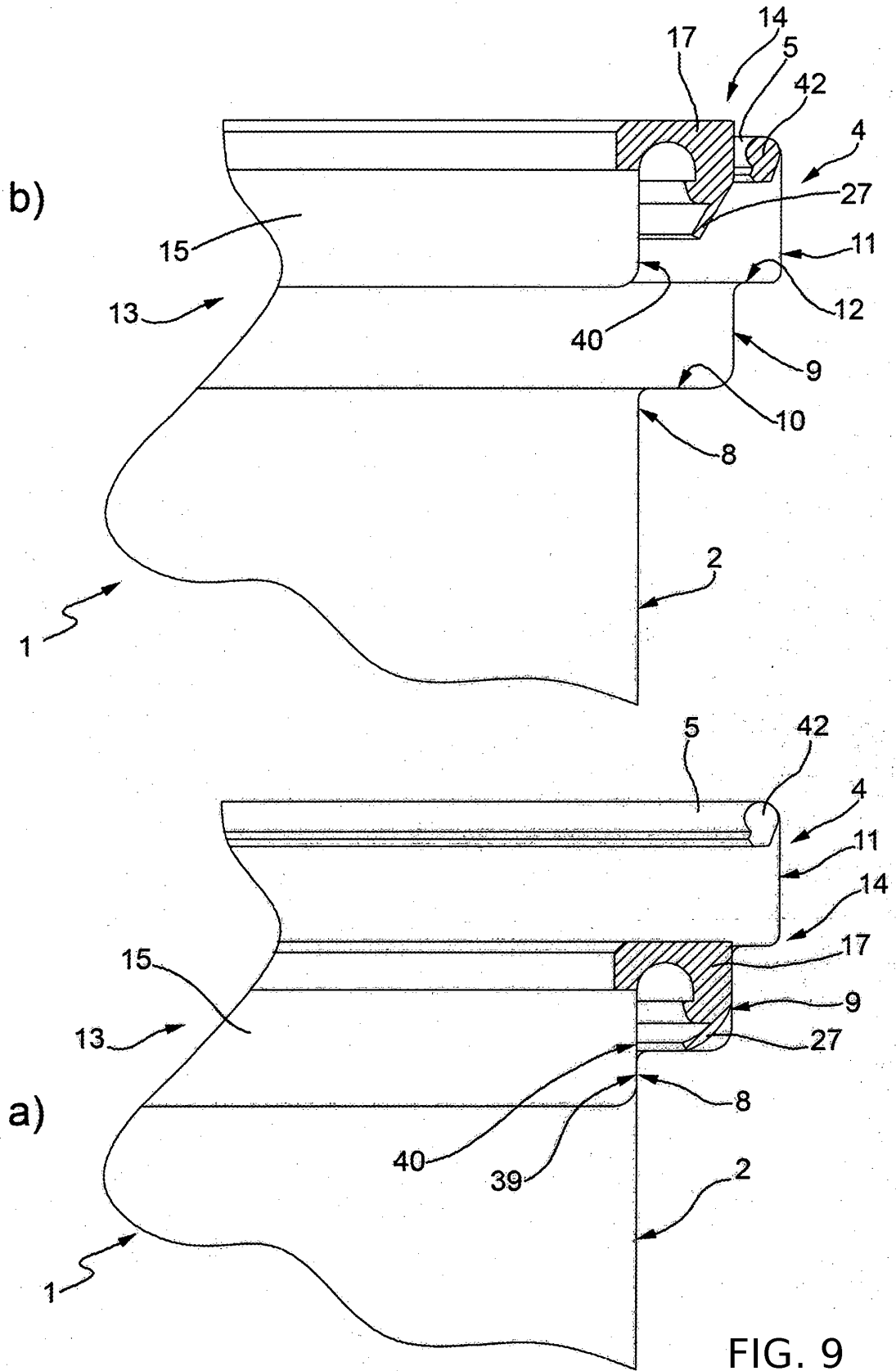

FIG. 9

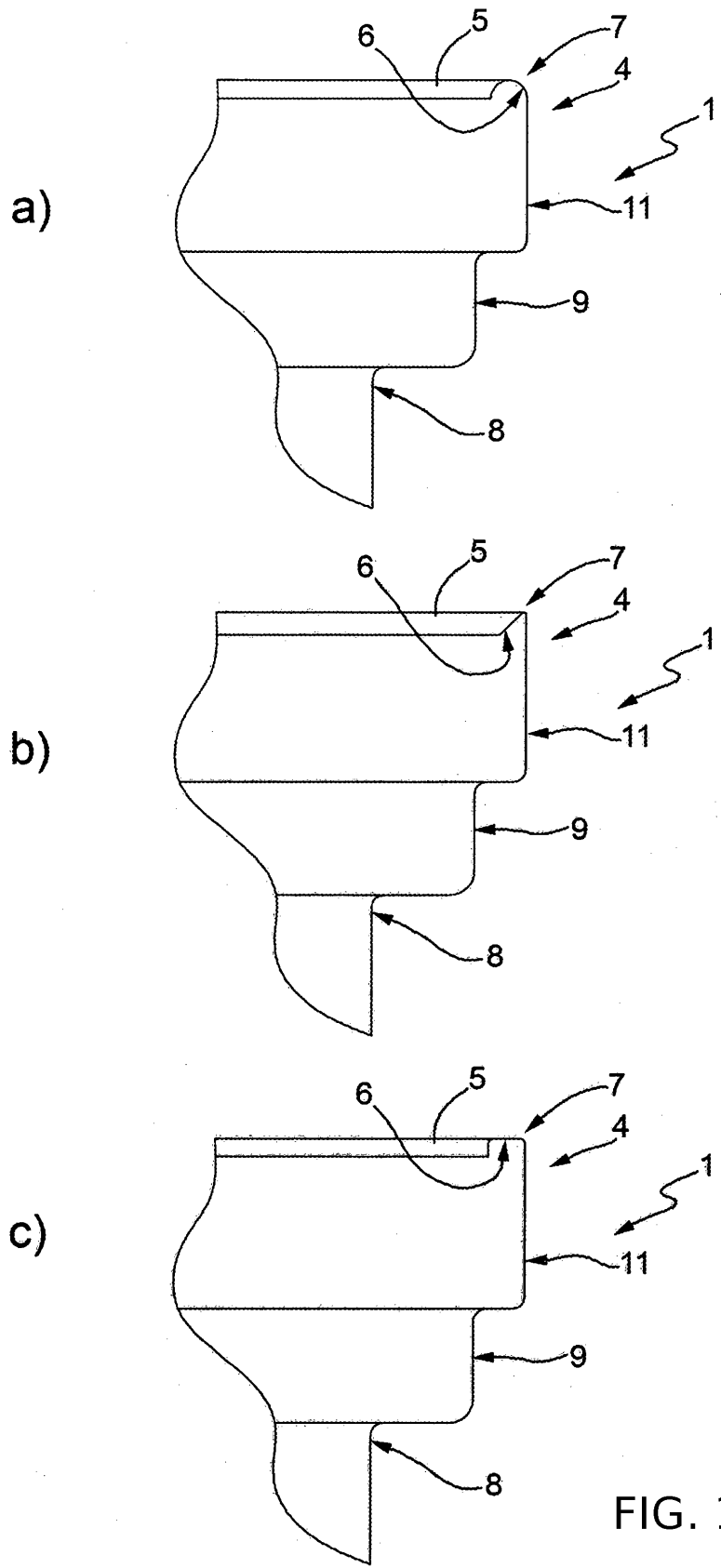

FIG. 10

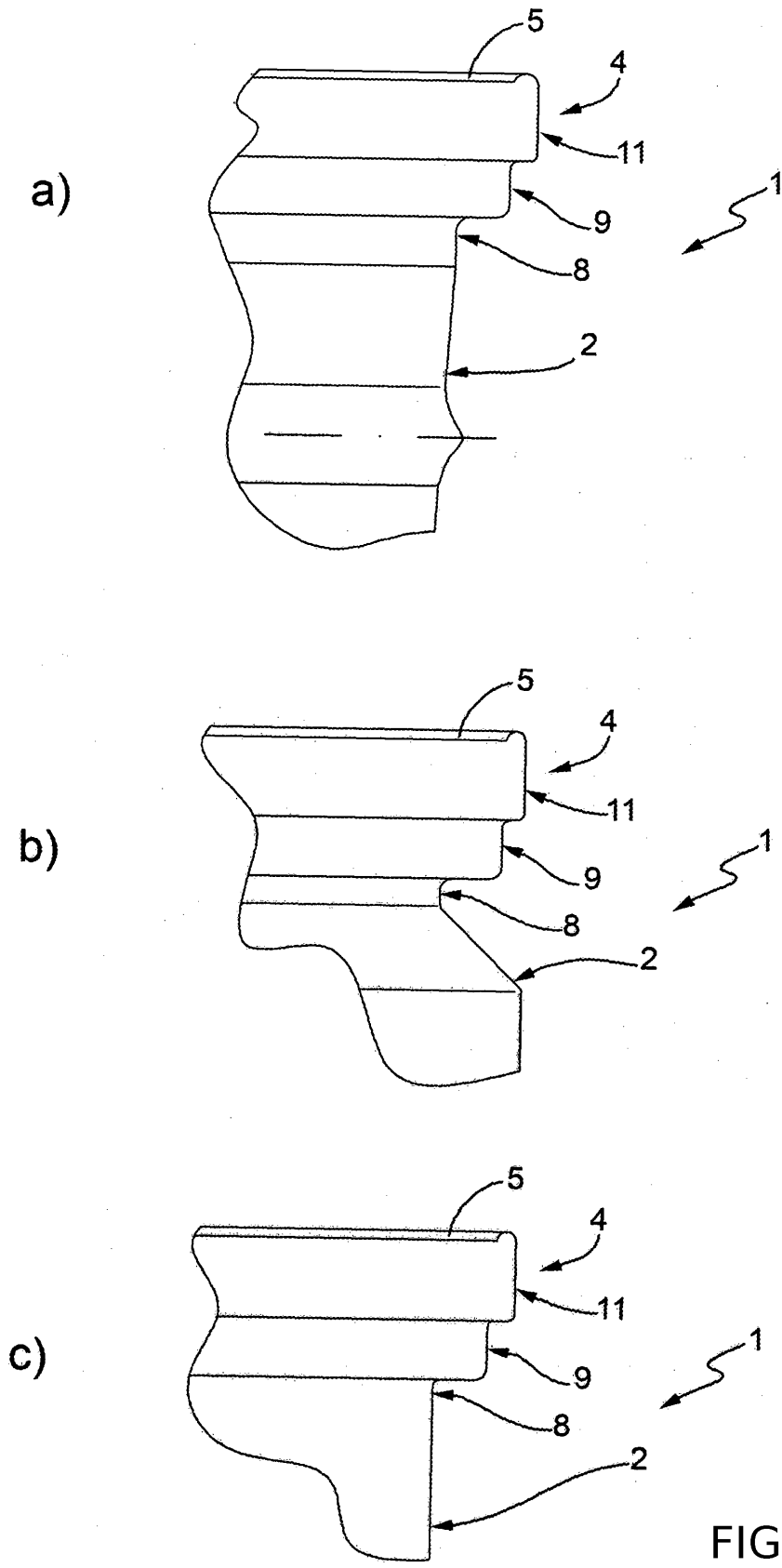

FIG. 11

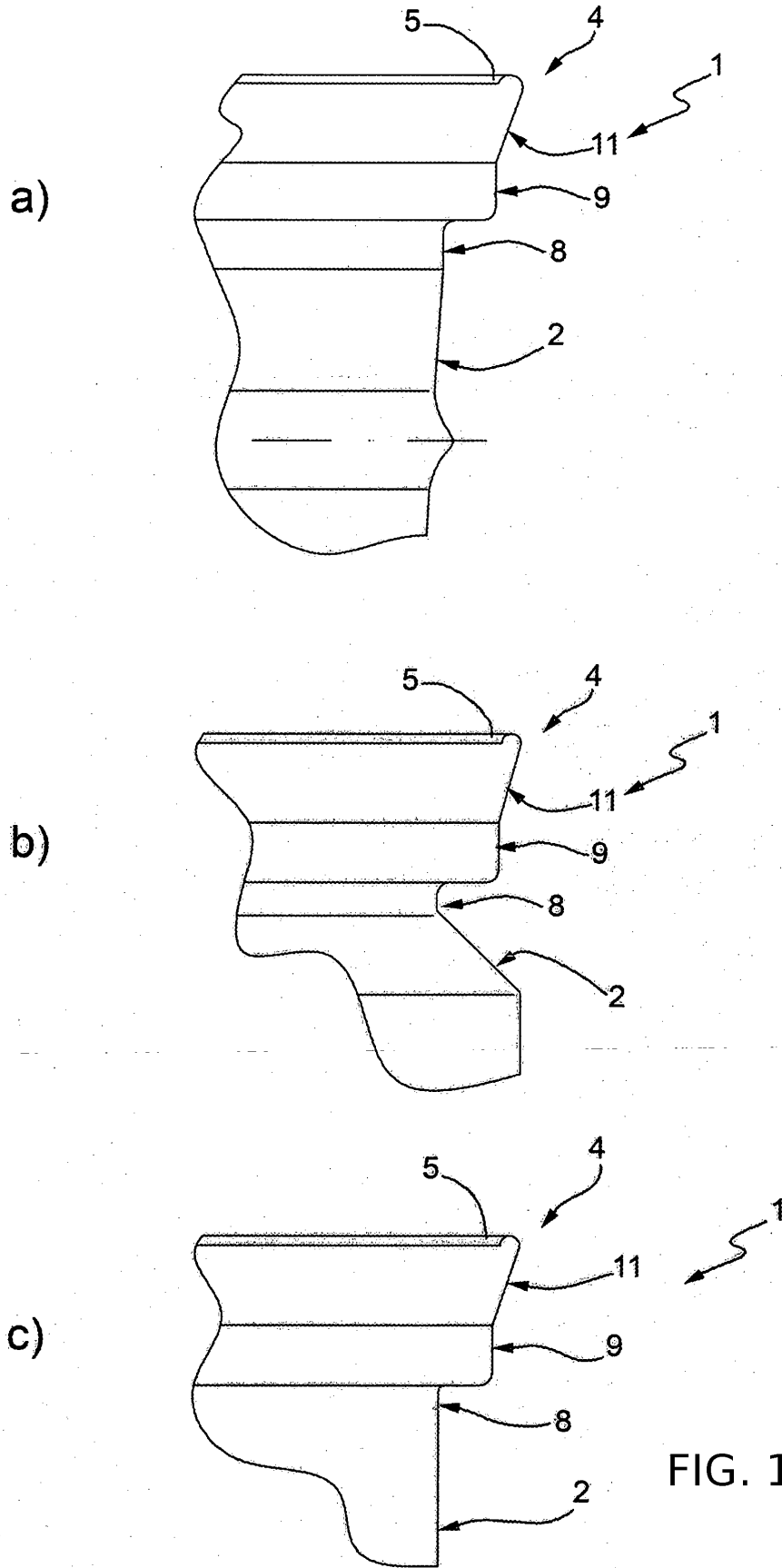

FIG. 12

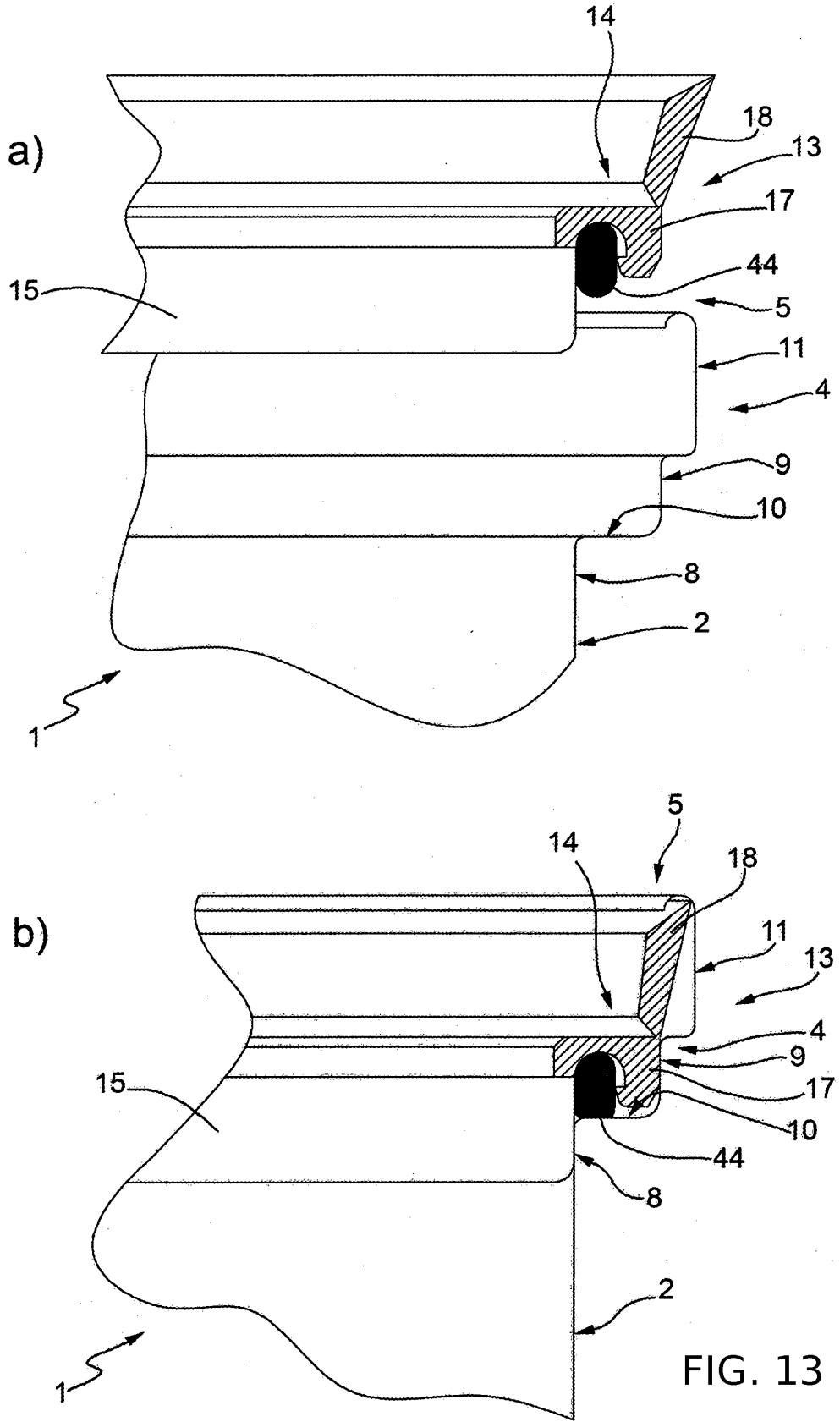

FIG. 13

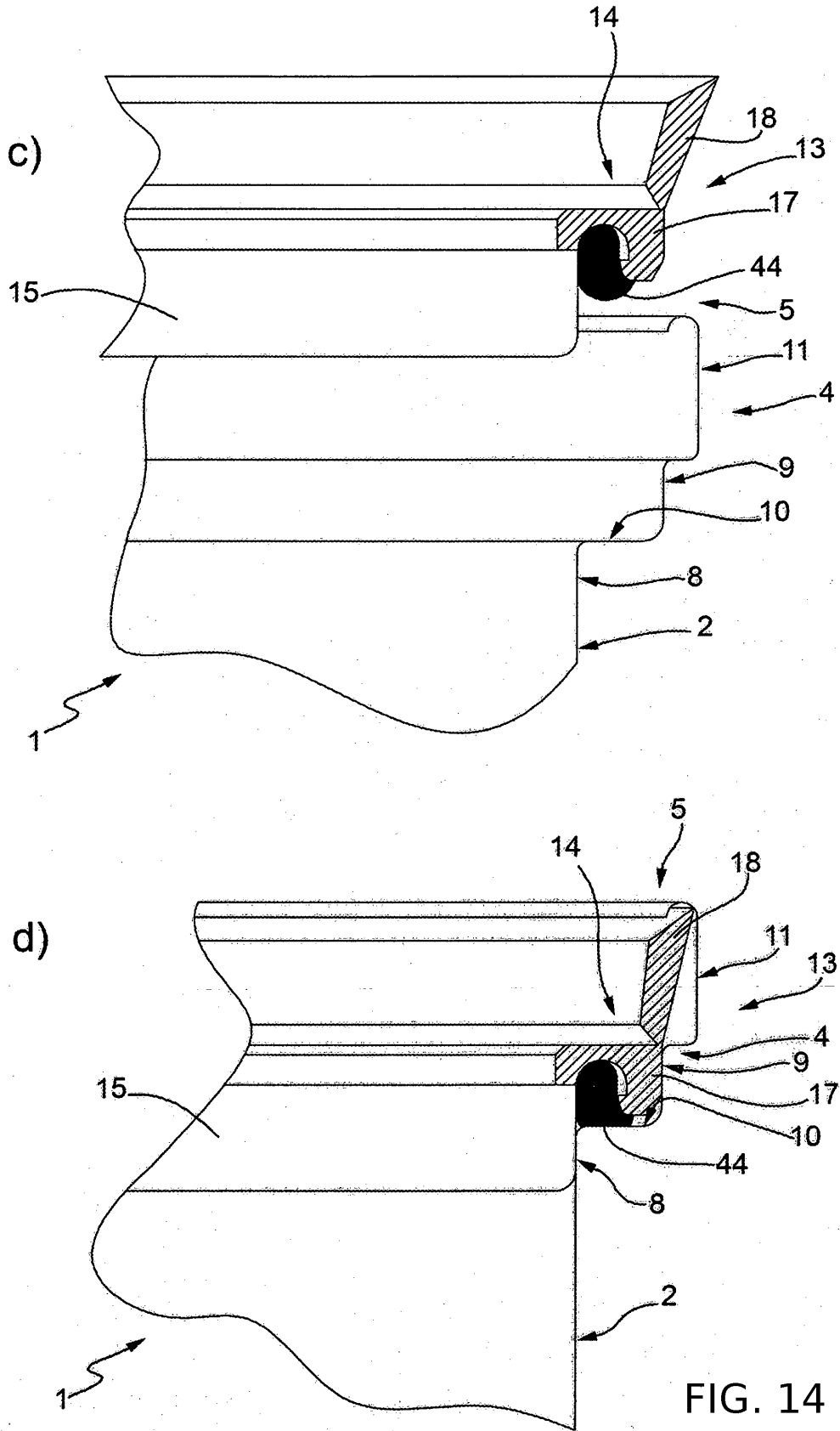

FIG. 14

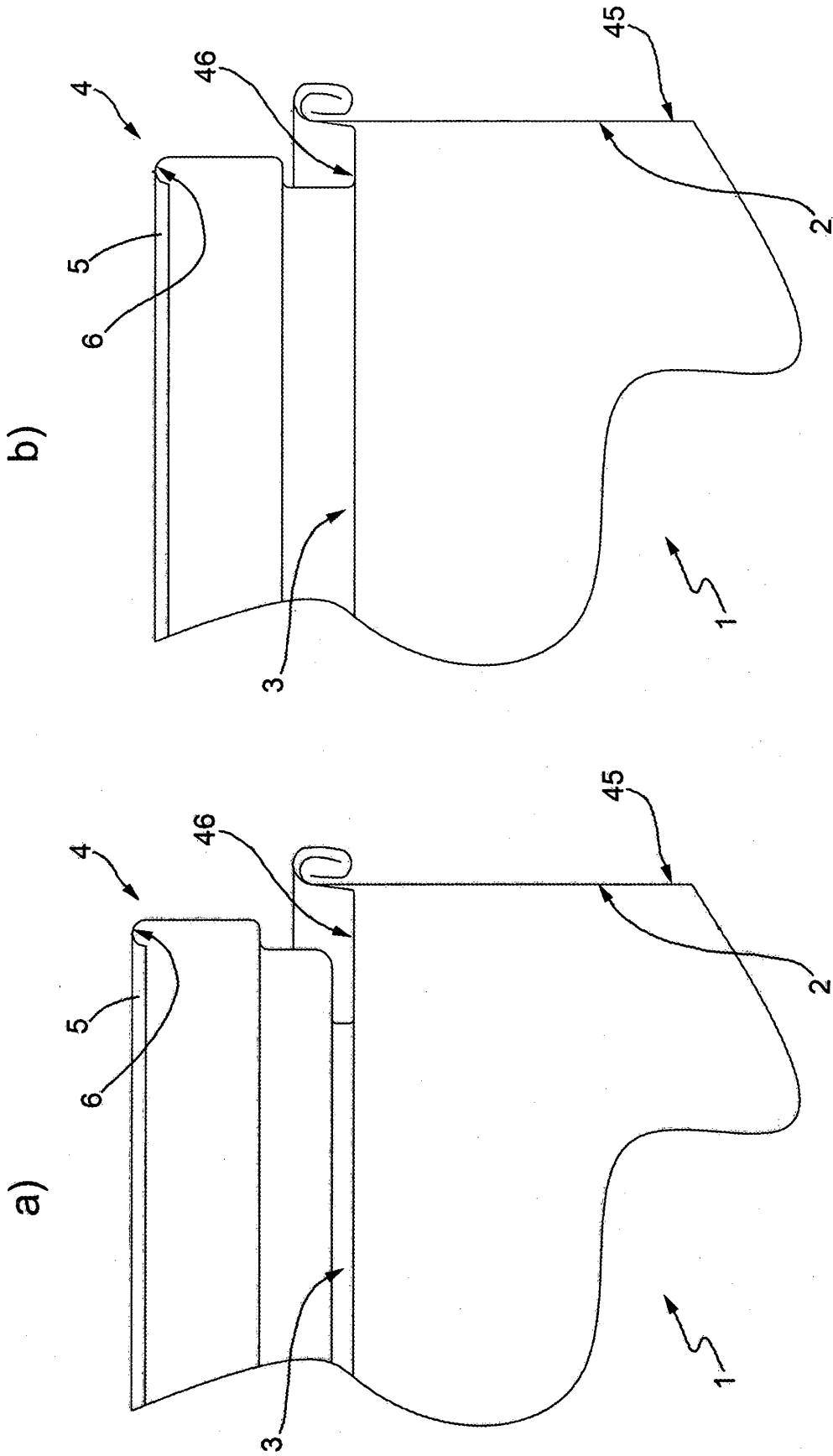

FIG.14

REFERENCES CITED IN THE DESCRIPTION

This list of references cited by the applicant is for the reader's convenience only. It does not form part of the European patent document. Even though great care has been taken in compiling the references, errors or omissions cannot be excluded and the EPO disclaims all liability in this regard.

Patent documents cited in the description

- NL 7113949 [0004]