



(11) **EP 2 255 428 B1**

(12) **EUROPEAN PATENT SPECIFICATION**

(45) Date of publication and mention of the grant of the patent:
14.10.2015 Bulletin 2015/42

(51) Int Cl.:
H01M 10/44 ^(2006.01) **H01M 10/48** ^(2006.01)
H02J 7/00 ^(2006.01)

(21) Application number: **09714939.7**

(86) International application number:
PCT/US2009/034947

(22) Date of filing: **24.02.2009**

(87) International publication number:
WO 2009/108613 (03.09.2009 Gazette 2009/36)

(54) **THERMAL RUNAWAY PROTECTION SYSTEM FOR A BATTERY CHARGER**

SYSTEM ZUM SCHUTZ VOR THERMISCHEM DURCHGEHEN FÜR EIN BATTERIELADEGERÄT
SYSTÈME DE PROTECTION CONTRE UN CLAQUAGE THERMIQUE POUR UN CHARGEUR DE BATTERIE

(84) Designated Contracting States:
AT BE BG CH CY CZ DE DK EE ES FI FR GB GR HR HU IE IS IT LI LT LU LV MC MK MT NL NO PL PT RO SE SI SK TR

(30) Priority: **29.02.2008 US 40577**

(43) Date of publication of application:
01.12.2010 Bulletin 2010/48

(73) Proprietor: **Schumacher Electric Corporation**
Mount Prospect, IL 60056 (US)

(72) Inventors:
• **JOHNSON, Thomas, F.**
Schaumburg
IL 60173 (US)
• **WHITING, John, S.**
Hampshire, IL 60140 (US)

(74) Representative: **Paustian, Othmar**
BOETERS & LIECK
Oberanger 32
80331 München (DE)

(56) References cited:
JP-A- 2003 153 436 **JP-A- 2008 043 027**
US-A- 3 889 172 **US-A- 4 114 083**
US-A- 4 609 861 **US-A- 5 179 335**
US-A- 5 204 611 **US-A- 5 214 370**
US-A- 5 396 163 **US-A- 5 574 355**
US-A1- 2002 109 506 **US-B1- 6 313 608**

- **DATABASE EPODOC [Online] EUROPEAN PATENT OFFICE, THE HAGUE, NL; XP002703330, Database accession no. JP-34448892-A -& JP H06 196206 A (SANYO ELECTRIC CO) 15 July 1994 (1994-07-15)**
- **DATABASE EPODOC [Online] EUROPEAN PATENT OFFICE, THE HAGUE, NL; XP002703331, Database accession no. JP-9686498-A -& JP H11 273749 A (SANYO ELECTRIC CO) 8 October 1999 (1999-10-08)**

Note: Within nine months of the publication of the mention of the grant of the European patent in the European Patent Bulletin, any person may give notice to the European Patent Office of opposition to that patent, in accordance with the Implementing Regulations. Notice of opposition shall not be deemed to have been filed until the opposition fee has been paid. (Art. 99(1) European Patent Convention).

EP 2 255 428 B1

Description**BACKGROUND OF THE INVENTION**5 **1. Field of the Invention**

[0001] The present invention relates to a protection system for use with a battery charger and more particularly to a protection system for a battery charger for detecting a thermal runaway condition during charging of a battery and protecting the battery when such a thermal runaway condition is detected.

10 [0002] More specifically, the presently claimed invention describes a method for detecting anomaly in electrical charging parameters during charging of a battery and a battery charger implementing said method, in the context of a battery charged with a charging current having a variable duty cycle and charged according to a charging cycle comprising a constant/ controlled current mode of operation followed by a constant voltage mode of operation.

15 **2. Description of the Prior Art.**

[0003] Various battery chargers are known in the art. Some known battery chargers include protection against a thermal runaway condition. Thermal runaway can cause overheating of a battery during charging which can result in damage to the battery as well as personal injury. Thermal runaway occurs as a result of heating of the electrical conductors in the battery during charging. More particularly, thermal runaway occurs when the electrolyte in the battery gets hot. When the electrolyte gets hot, heat is transferred from the electrolyte to the electrical conductors within the battery causing the temperature of those conductors to rise. Since, the resistance of an electrical conductor is inversely proportional to the temperature of the conductor, the resistance of the electrical conductor decreases. Thus, if the battery charger is providing a constant voltage to the battery under charge, the current will increase in proportion to the decrease in resistance. During such a condition, the battery voltage does not increase even though the charging current is increased. The battery voltage is known to either remain the same or decrease. The increased charging current causes the electrolyte to get even hotter, resulting in the even more charging current to be drawn by the battery placing the battery in a thermal runaway condition. The risk of a battery experiencing a thermal runaway condition is increased during relatively high ambient temperature conditions.

30 [0004] The effect on the battery as a result of a thermal runaway condition depends on the type of battery. For example, in flooded electrolyte batteries, such as lead acid batteries, a thermal runaway condition can cause the electrolyte to boil off; thereby disabling the battery. In sealed batteries, a thermal runaway condition can cause expansion of the electrolyte and an explosion of the battery and possibly personal injury.

35 [0005] Various hardware solutions have been proposed to solve the thermal runaway problem of a battery. Examples of such hardware solutions are disclosed in US Patent Nos. 5,214,370 and 6,020,721 as well as US Patent Application Publication No. US 2007/0018780 A1 and International Patent Application Publication No. WO 2004/097956 A2.

40 [0006] These hardware solutions all rely on temperature sensors to detect the battery temperature and the ambient temperature. The temperature sensors for detecting the temperature of the battery are known to be connected to various locations on a battery, such as the battery terminals, the plates in the battery or in the electrolyte. The temperature sensors for sensing the ambient temperature are disposed within the battery charger. By detecting the battery temperature during charging, the battery charger can detect when a battery is experiencing a thermal runaway condition.

45 [0007] Although such battery chargers which rely on external temperature sensors to detect and protect against a thermal runaway condition, there are several problems with such systems. In particular, many conventional batteries are not known to be provided with temperature sensors. As such, temperature sensors must be provided along with the battery charger and connected to the battery. These temperature sensors are typically configured to be connected to a surface of a battery or to a battery terminal to provide an indication of the battery temperature during charging.

[0008] There are several known problems with such hardware solutions. For example, in automotive and marine battery charging applications, battery temperature sensors are most often not provided with the battery. Thus, the use of external temperature sensors must be relied upon. However, the service technicians may not always connect the temperature sensors to the battery surface or battery terminals. Without the battery temperature, the battery charging system is unable to detect a thermal runaway condition. Moreover, the electrical conductors attached to the temperature sensors may eventually break off after repeated use.

50 [0009] The '721 patent accounts for such a situation and provides a monitoring circuit for monitoring for broken or disconnected electrical conductors that are connected to the temperature sensors. In the event that a disconnected or broken electrical conductor is detected, the battery charger is placed in a fail safe condition and charging is suspended. Such a solution essentially renders the battery charger unusable until the broken wire is repaired. Moreover, if the thermistor used to sense battery temperature is damaged or becomes disconnected from the electrical conductor or becomes misplaced, the battery charger is rendered inoperable

5 [0010] In order to avoid such problems, some known battery chargers do away with the need for battery and ambient temperature sensors altogether and simply rely on a manual ambient temperature switch on the battery charger and rely on the user selecting an ambient temperature range. For example, such a manual temperature switch is provided on a 15 Amp Smart Battery Charger as manufactured by West Marine of Watsonville, California. That battery charger includes a manual ambient temperature selector which allows a technician to manually select three different ambient temperature conditions:

- Cold: 0 °C - 15.56 °C (32°F - 60 °F)
- Warm: 15.56 °C - 29.44 °C (60 °F - 85 °F)
- 10 • Hot: 29.44 °C - 40°C (85°F - 104 °F)

15 [0011] In such an application, the user selects an ambient temperature range before charging. Although relative high ambient temperatures can result in a thermal runaway condition, the system does not take into account the temperature of the battery and thus is a relatively crude and inaccurate method for detecting a thermal runaway protection. Moreover, the technicians may not always remember to set the manual ambient temperature switch.

[0012] Thus there is a need to provide a protection system and method for detecting a thermal runaway condition in a battery and providing protection of the battery when a thermal runaway condition has been detected which does not require the use of external temperature sensors or any actions by a technician or operator.

20 SUMMARY OF THE INVENTION

25 [0013] The present invention relates to a protection system and method for a battery charger for detecting a thermal runaway condition in a battery during charging in order to protect the battery when such a thermal runaway condition has been detected. The protection system in accordance with the present invention does not require external temperature sensors nor does it rely on actions by the technician or user. Briefly, the protection system includes one or more electrical sensors normally provided with conventional battery chargers for sensing one or more electrical parameters during charging and providing an indication of a possible thermal runaway condition based upon the trend (i. e. rate of change) of the electrical charging parameters. In general, the protection system monitors the charging characteristics of a battery for a complete or partial charging cycle. If the charging characteristics deviate from a normal or otherwise indicate an anomaly, as determined by software, the system assumes there may be a thermal runaway condition and executes a protection measure, such as terminating charging of the battery. Even though the anomaly may not be the result of a thermal runaway condition, the protection system in accordance with the present invention treats the anomaly as a problem that requires corrective action. For example, when the anomaly is the result of a bad cell, battery charging is terminated to prevent a thermal runaway condition and not because a thermal runaway condition is detected.

35 [0014] US 2002/109506 A1 describes a CCCV method of charging a battery wherein the voltage variation with time during the constant current charging step is regularly measured to indicate a possible battery short-circuit.

[0015] JP 2003 153436 A discloses the features of the preambles of claims 1 and 7. In this document it is proposed to rely on a maximum current value and/or maximum voltage value as an indication of anomalies.

40 [0016] The object of the present invention is to improve the detection of failures in charging a battery in order to better react to potential anomalies in electrical charging parameters, including improving the chances to get the battery fully charged automatically.

[0017] This object is achieved by the features of claim 1 or 7.

45 DESCRIPTION OF THE DRAWING

[0018] These and other advantages of the present invention will be readily understood with reference to the following specification and attached drawing wherein:

50 Fig. 1A is graphical illustration of exemplary charging characteristics of a West Marine SeaVolt (TM) Deep Cycle 75 battery being charged by a DieHard (TM) Model 71227 battery charger with an exemplary thermal runaway condition shown near the end-of- charge condition.

55 Fig. 1B is an exemplary diagram of the charging characteristics for an exemplary battery which illustrates the various stages of a typical charging cycle.

Fig. 2 is an exemplary software flow diagram for an exemplary embodiment of the main charging loop for use with a battery charger in accordance with the present invention.

Fig. 3 is a software flow diagram for a VoltReg subroutine in accordance with one embodiment of the present invention.

Fig. 4 is a software flow diagram for a TRcheck subroutine in accordance with one embodiment of the present invention.

Fig. 5 is a block diagram of a battery charger that is configured to detect a thermal runaway condition and provide protection of the battery during such a condition.

DETAILED DESCRIPTION

[0019] The present invention relates to a protection system for a battery charger that utilizes software to detect a thermal runaway condition, thereby eliminating the need for external temperature sensors and which does not rely on actions by the technician or user. Briefly, the protection system includes one or more electrical sensors for sensing one or more electrical parameters and determining a thermal runaway condition based upon the trend (i. e. rate of change) of the electrical charging parameters. In general, the system monitors the charging characteristics of a battery during a normal charging cycle. If the charging characteristics deviate from a normal charging cycle by a significant amount as determined by software, the system assumes a thermal runaway condition. For example, in one embodiment of the invention, the voltage and current is monitored during an initial phase of the charging cycle in which the charging current is held constant or controlled and the voltage is monitored.

[0020] During a normal charging cycle, the battery voltage will continually ramp up to a predetermined value or a point at which point $dV/dt = 0$ during an initial phase. During this initial phase of the charging cycle, the battery voltage is monitored along with the charging current. Should the battery voltage fail to continually ramp up or if additional charging current beyond the nominal is required to get the voltage of the battery to the point where $dV/dt = 0$, then the software assumes a thermal runaway condition exists. Alternatively, the battery voltage may be monitored during an initial phase. Should the battery voltage fail to reach a predetermined voltage, for example, in a predetermined amount of time, a thermal runaway condition is presumed.

[0021] During a subsequent phase of the charging characteristic, i.e a constant voltage phase of the charging cycle, the voltage and current are monitored. During a normal charging cycle, a decreasing amount of charging current is required to maintain a constant battery voltage. Should the system detect an anomaly, such as, increases in the amount of charging current while the voltage is constant, a thermal runaway condition is assumed. Alternatively, during the constant voltage phase of the charging cycle, should any increase in charging current be detected or any increase with respect to time, i.e. di/dt , the system assumes a thermal runaway condition. In the presently claimed invention, the system monitors the duty cycle of the charging current and tracks the trend (i. e. rate of change) in the duty cycle throughout a charging cycle. When the trend (i. e. rate of change) in the duty cycle indicates an anomaly, a thermal runaway condition is indicated. By providing a software method for detecting a thermal runaway condition, the problems associated with external temperature sensors mentioned above are eliminated.

[0022] The invention is best understood with reference to Figs. 1A and 1B, which illustrate exemplary charging characteristics for an exemplary battery. The curve 20 (Fig. 1A) represents closed circuit battery charging voltage as a function of time, while the curve 22 represents current as a function of time for an exemplary lead acid battery, such as a West Marine SeaVolt (TM) Deep Cycle 75 battery. During a normal charging cycle, the battery is charged with a constant current.

[0023] As used herein constant current charge mode is defined as an initial portion of the charging cycle, for example as illustrated in Figs. 1A and 1B. The principles of the present invention are also applicable to battery chargers in which initial portion of the charging cycle is an alternating DC current, as generally described in US patent application no. 11/487,071, filed on July 14, 2006, published as US Patent Application Publication No. US 2007/0114970 A1 on May 24, 2007, entitled "Battery Charger and Method Utilizing Alternating DC Charging Current".

[0024] As shown in Fig.1A, the battery is charged in a constant current mode for about 3.5 hours. During the constant current mode, the closed circuit charging voltage continually rises from about 11.9 volts DC to about 14.2 volts DC as a result of the battery voltage rising. More particularly, the closed circuit charging voltage is the sum of the open circuit battery voltage V_{BATT} + the product of the charging current I_{CHARGE} and the resistance of the battery circuit $R_{CIRCUIT}$. The resistance $R_{CIRCUIT}$ includes the internal battery resistance + the battery terminal resistance + the resistance of the battery charging circuit. Thus during a constant current mode an increase of battery voltage V_{BATT} resulting from charging results in an increase in the closed circuit charging voltage.

[0025] As mentioned above, in accordance with the present invention, the charging characteristics are monitored to determine if they follow the normal charging characteristics. Any anomalies in the charging characteristics are assumed by the software to represent a condition, for example, a thermal runaway condition, that requires correction. For example, during a constant current mode, should the battery closed circuit voltage begin to drop; above average current be required to cause closed circuit voltage level to rise to a predetermined level; or an above average time be required for the closed

circuit voltage to rise to a predetermined level or any combination of the above are treated as a thermal runaway condition.

[0026] Fig. 1A illustrates an exemplary constant voltage mode, when $dV/dt=0$ about 5.6 hours. As shown, there is a transition mode between the constant current mode and the constant voltage mode. During the transition mode, the charging current is reduced from 15 amperes DC to about 12 amperes DC. During this transition mode, the battery closed circuit voltage rises to about 15.3 volts DC, where it is maintained due to the increased open circuit battery voltage VBATT- This point is identified in Fig.1A as a point of constant voltage or $dV/dt=0$. In particular, the system remains in a constant voltage mode from the point $dV/dt=0$ until the battery is fully charged, i.e. at an end of charge condition. Under normal conditions, an end of charge condition is assumed when the charging current drops below a predetermined charging current or the charging current levels off in a constant voltage mode of operation.

[0027] Should any anomalies occur during the transition mode or the constant voltage mode, the system assumes a thermal runaway condition. During a transition mode, any anomaly is assumed to be a thermal runaway condition. For example, should the closed circuit charging voltage drop or the time to reach the constant voltage state, i.e. dV/dt , be too long relative to a normal charging characteristic, or the current increase during the transition mode, a thermal runaway condition is assumed.

[0028] As mentioned above, the battery charger is in a constant voltage mode when $dV/dt=0$. The battery charger remains in a constant voltage mode until the charging current continuously drops. When the charging current drops below a predetermined value or levels off, the battery is considered to be at an end of charge condition. This value is normally determined to be the value that is slightly greater, for example 5% greater, than the amount of discharge of the battery from a fully charged condition.

[0029] At about 5.7 hours, the charging current is intentionally increased resulting in an increase in the closed circuit charging voltage. Such increases are typical for deep cell batteries and does not represent an anomaly. At about 6.2 hours, identified by the reference numeral 24, the closed circuit voltage begins dropping while the charging current 20 is increasing. Such a condition represents an anomaly, which is assumed by the protection system to be a thermal runaway condition. As such the end of charge stage was terminated much sooner than normal, i.e about 48 minutes instead of the normal 75 minutes.

[0030] A thermal runaway condition may also be based upon a rate of change of charging current. More particularly, with reference to the curve 22, the current curve 22 illustrates the charging current normally decreasing, i.e having a negative slope, from about 3.5 hours to about 5.7 hours where the charging current levels off at about 12 amperes. During a normal charging cycle, the charging current should either continue to decrease or continue leveling off. Should the charging current begin to increase, i.e switch to a positive slope, in the constant current mode or any mode any mode without a corresponding increase in closed circuit voltage, the system also assumes a thermal runaway condition.. In other words should the rate of change of current with respect to time, i.e. di/dt , goes from a negative slope or 0 to a positive slope without a corresponding increase in the closed circuit charging voltage, a thermal runaway condition may be assumed..

[0031] Figs. 2-4 illustrate exemplary software for detecting a thermal runaway condition in accordance with one aspect of the invention. The present invention can be implemented on virtually any battery charger, for example, the battery charger, illustrated in Fig. 5 and identified with the reference numeral 10, disclosed in commonly owned co-pending US Patent Application Publication No. 2005/0088144 A1, which includes a microprocessor/microcontroller 12. Moreover, the principles of the present invention are applicable to any battery types, such as lead acid, absorbed glass mat (AGM), spiral wound AGM valve regulated lead acid (VRLA), flooded cell and deep-cycle batteries, generally identified by the reference numeral 16.

[0032] Referring to Figs 2-4, the main software loop is illustrated in Fig. 2. This loop runs continuously, for example, at 120 times per second during the entire charging cycle of a battery to account for the fact that the 60 Hertz AC input power provides a 120 Hertz waveform on the secondary of the charger step down transformer. Initially in step, 26, after the charge rate is selected by the user, for example, 2, 10, 12 or 15 amperes, the system checks the battery voltage in step 28 to determine whether the the battery cycle is in the constant current mode or the constant voltage mode. As illustrated in Fig. 2, an exemplary value of 14.2 volts DC is selected as a threshold for determining the mode of the battery cycle. If the battery closed circuit voltage is less than the threshold value of 14.2 volts, the system forces the battery cycle to be in the constant current mode, for example as indicated in Fig. 1A. As mentioned above, any anomaly relative to a normal charging cycle is considered to be a thermal runaway condition. In this exemplary embodiment, the system measures the time it takes the battery to reach a threshold voltage value of, for example, 14.2 volts DC, roughly 93% of the constant voltage value of 15.3 volts DC (Fig. 1A). In this embodiment, the system assumes a constant current mode as long as the elapsed time since the charge limit is less than a limit value, for example, 3.0 hours, as illustrated in Fig. 1A as illustrated in step 30. If the elapsed time is less than the limit, the system loops back to step 26 in order to adjust the charge rate based upon the most recent closed circuit battery voltage measurement.., for example 120 times per second, and rechecks the battery closed circuit voltage again This process continues until the battery open circuit voltage becomes greater than the threshold value. In this embodiment, should the voltage continue to be less than the threshold voltage of 14.2 volts and the elapsed time since the charge rate was set exceed the time limit mentioned

above, the system assumes an anomaly, such as, a thermal runaway condition, and aborts charging in step 32. Such a scenario can occur in relatively high ambient temperature conditions.

5 [0033] Other parameters other than time and voltage could also be used to detect a thermal runaway condition during a constant current mode of operation. For example, the rate of change of the voltage could be used as an indication of a thermal runaway condition. With reference to Fig. 1A, the voltage curve 20 has a relatively linear positive slope during a constant current mode of operation. Thus the rate of change of voltage, dV/dt , or slope as a function of various other parameters can be used to indicate a thermal runaway condition. These other parameters include time, charging current, the rate of change of charging current, di/dt , and voltage. Moreover, any combination of these parameters can be used to indicate an anomaly in a normal battery charging cycle and thus indicative of a thermal runaway condition. 10 All of such embodiments are within the scope of the present invention.

[0034] Once the system determines that the battery open circuit voltage is greater than or equal to the threshold value, for example, 14.2 volts DC, the system checks in step 34 whether the cycle has just reached the constant voltage mode, i.e. the point where $dV/dt=0$. In step 36, the system checks if the charging cycle is in the constant voltage mode of operation but beyond the initial point of $dV/dt=0$. If so, the system calls the VoltReg subroutine (Fig. 3) in step 38. The 15 VoltReg subroutine controls the duty cycle of the charging current to regulate the battery voltage. In particular, during a constant voltage mode of operation, the VoltReg subroutine controls the duty cycle of the charging current to maintain a constant charging voltage.

[0035] In the presently claimed invention, the system monitors the duty cycle of the charging current and the upward and downward trends (i. e. rates of change) in the duty cycle and uses these parameters to indicate a thermal runaway condition. In particular, the variable DUTY is used to track and control the duty cycle of the charging current. The variable 20 DT relates to the Duty Trend and is used to track the up/down trend (i. e. rate of change) of the duty cycle. In step 40, the system determines whether it is time to check the duty cycle.

[0036] Typically, the duty cycle is maintained constant after the battery closed circuit voltage reaches about 14.2 volts DC. i.e. the end of the constant current mode, until the end of the constant voltage mode. The duty cycle is generally 25 not varied after the constant current mode to maintain a constant voltage or a constant current. For linear chargers, constant duty cycle results in constant power. Accordingly, the charging current decreases as the battery voltage rises and thus the closed circuit battery charging voltage rises. Some known high frequency chargers are also known to operate in the same manner. Other known high frequency chargers are known to operate such that a constant current is maintained until the end of the transition mode.

30 [0037] The interval for checking the duty cycle during a constant current mode is a fixed interval, such as about 10 minutes plus or minus a few minutes. The system checks the duty cycle for every 3 or 4 consecutive values that have not changed to determine if di/dt is close to zero. In an exemplary embodiment, the first time the system checks a flag is set to allow for thermal runaway checkink. That way, fluctuations that are typical for the start of the constant current mode are not treated as thermal runaway. Also, the constant current mode is guaranteed to last for at least the first 35 checking interval.

[0038] If it is time to check the duty cycle output, the system checks the duty trend (i. e. rate of change) DT. As mentioned above, an anomaly in the duty cycle during the constant current portion of the charging cycle may be indicative of a thermal runaway condition. For example, as illustrated in Fig. 1A and 1B, a decrease in the battery voltage during the constant current mode of the charging cycle may be used to indicate a thermal runaway condition. Thus, if it is not 40 time to check the duty cycle as indicated in step 40, the TRcheck subroutine is called in step 40 to determine if a thermal runaway condition exists without setting the CheckDT flag in step 44.. If the system determines in step 40 that it is time to check the duty cycle of the charging current, a Check DT flag is set in step 44. before the TRcheck subroutine is called in step 42. The system checks in step 46 if a TRstop flag is set by the TRcheck subroutine, indicating a thermal runaway condition. If so, a rest timer is started in step 48 and the charging current is reduced to provide a rest period to enable 45 the components to cool.

[0039] The rest timer may be set, for example to a predetermined value. For example, a rest period of about 3 minutes is set between periods of high current, which are typically less than 2 minutes. An exemplary charge time may be selected as 5 minutes followed by five minutes of rest to minimize the risk of a thermal runaway condition. Rather than cycle 50 between charge and no charge, the system can be cycled from a high charge rate to a low charge rate or a combination of the above.

[0040] In step 50, the system checks whether the rest timer is timed out. If not, the system proceeds to step and awaits for the rest timer to time out. Once the rest timer times out, a cycle timer is started in step 54 and normal charging current is resumed.. The system checks in step 52 whether the cycle timer has timed out. If not, the rest timer is restarted and the charging current is reduced.

55 [0041] If the system determines in step 36 that the charging cycle is not in a constant current mode, the system next checks in step 56 whether the battery cycle is in an end of charge state, As illustrated in Fig. 1B, the end of charge state occurs during a constant voltage mode after a di/dt state and before a maintenance state. An end of charge mode is used for certain battery types, such as deep cell batteries, to put as much charge on the battery as possible. As shown

in Fig. 1A, the end of charge state begins at about 5.8 hours. The end of charge state may typically be from 15 minutes to 2 hours or not be used at all depending on the type of battery being charged. During such an end of charge state, the duty cycle of the charging current is increased to increase the battery voltage.

[0042] The maintain state is used to keep fully charged batteries charged. In a maintain state, the closed circuit charger voltage is held to a voltage lower than the normal charging voltage but higher than the open circuit battery voltage. For 12 volt batteries, the maintain voltage ranges from 13.2 to 13.6 volts DC depending on the charger and the battery type. If a battery is fully charged, minimal charging current, for example, < 100 milliamps is required to maintain state is illustrated at beginning at about 6.65 hours.

[0043] If the charging cycle is not in an end of charge state, the system proceeds to step 52 and returns to the main loop. If the system determines that the charging cycle is in at end of charge state, the system calls the VoltReg subroutine in step 58 to adjust the duty cycle of the charging current to provide a maintenance voltage, such as, 13.5 volts DC to the battery. After the maintenance voltage is set in step 60, the system checks whether the duty cycle of the is less than the DtyLmt. The DtyLmt is a variable used to track the maximum duty cycle used for voltage regulation. If the duty cycle is less than the duty limit DtyLmt , as determined in step 60, the system checks whether the regulation target voltage MaintVolt is greater than the battery voltage in step 62.

[0044] The variable MaintVolt is the regulation target voltage value of the voltage output of the battery charger which varies throughout the charging cycle. For example, with reference to Fig. 1A and 1B, the charging voltage is varied during the constant current mode to maintain the constant current. The charging voltage is about 15.4 volts during an End Of Charge mode, as discussed above and about 13.2 volts (not shown) during a maintenance mode.

[0045] If so, the Duty Trend variable is cleared in step 64 and the system proceeds to 52 and returns to the main loop. If the regulation target voltage MaintVolt is less than the battery voltage, the system calls the TRcheck subroutine in step 66 . In step 68, the system checks whether a TRstop flag has been set. The TRstop flag indicates a thermal runaway condition. If so, the battery charger remains in a maintenance charge state in step 70 and proceeds to step 72 and returns to the main loop.

[0046] If the system determines in step 34 that the battery charger is in the , dV/dt state (Fig. 1 B), the system next checks in step 35 whether the battery charger is at the end of the constant voltage mode. As mentioned above, the end of the dV/dt state is determined when the charging current is less than a predetermined minimum value, for example, < 100 milliamps or leveling off at a constant value. If not, the system proceeds to step 36 and proceeds as discussed above. If the system does indeed detect that the state of the charging cycle is at the end of the dV/dt state, the Duty Trend is cleared and a variable check DT State is set to the dl/dt state in preparation of the next charging cycle in step 37 and the system returns to the start of the main loop in step 39.

[0047] The VoltReg subroutine is illustrated in Fig. 3. As mentioned above, this subroutine is used to adjust the duty cycle of the charging current. In response to a call from the main program (Fig. 2), the VoltReg subroutine determines whether an increase or decrease in the duty cycle is required in steps 74 and 76. If a no change in the duty cycle is required , control proceeds to step 78 and the system returns to the main loop (Fig. 2). If an increase in the duty cycle is required, the system checks the duty trend (i. e. rate of change) DT. In particular, if it is determined in step 78 that the duty cycle is being increased and the duty cycle in the previous cycle was increased, a DutyTrend counter is incremented by one indicating an increasing voltage trend in step 80 before the system returns. If the duty cycle in the previous cycle was decreased, the system proceeds to step 78 and returns to the main loop. If the duty cycle is currently being decreased , the system checks the DutyTrend counter to determine if it is at 0 in step 82. If so, the system proceeds to step 78 and returns to the main loop. If not, the DutyTrend counter is decreased by one in step 84 before the system returns to the main loop.

[0048] An exemplary TRcheck subroutine is illustrated in Fig. 4. As mentioned above, in this exemplary embodiment, theTRcheck subroutine is used to determine a thermal runaway condition. Initially in step 86, the DutyTrend counter is checked to determine if it is less than DTlimit, an integer greater than 3 that depends on the speed of the voltage regulation and charger hardware, used to indicate a thermal runaway condition. If the DutyTrend counter value is greater than DTlimit, the system proceeds to step 88 and checks whether the current duty cycle is greater than DutyLmt, a variable used to limit the maximum duty cycle for the charging current. The duty cycle limit depends upon the charge rate selected and the charger hardware. Typically, the duty cycle limit is higher for higher charge rates. Many known chargers use 100% duty cycle when an engine start function is incorporated into the battery charger. In such an application, the maximum duty cycle would depend on the ratio of the charge rate selected to the engine start rate. Typically, the duty cycle will be higher during a constant current mode than in a maintenance mode. Thus the duty cycle limit could range from a few per cent to 100% depending on the factors discussed above.

[0049] If the duty cycle is less than the variable DtyLmt, a TRstop flag is set in step 90 indicating a thermal runaway condition. In some known battery chargers, the voltage is boosted in an end of charge condition. In order to avoid triggering a thermal runaway indication, the system checks in step 88 whether the duty cycle is greater than the variable DutyLmt. If so, the DutyTrend counter is cleared and a di/dt counter is cleared in step 94. Also, the target regulation voltage , i.e MaintVolt is decreased, and a dl/dt counter is incremented. If the duty cycle is too high, it is possible that

the target regulation voltage was too high. Therefore, in such a situation, instead of assuming a thermal runaway condition in such a situation, the charger reduces the target regulation voltage, i.e. MaintVolt, which should reduce the charge rate. The Duty Trend variable is cleared because the constant voltage mode is restarted at a lower charge rate. The di/dt counter, i.e cycle timer, is set to a nominal value, for example 4, when the constant voltage mode is started. The duty cycle is checked at preset intervals, as indicated in step 40 in Fig. 2. The di/dt counter is decreased if the duty cycle stops decreasing. If the di/dt counter reaches 0, this means that the duty cycle has leveled off and the constant voltage mode is finished. If the constant voltage mode is restarted at a lower target regulation voltage, the di/dt counter is incremented so that the constant current mode continues for at least another checking cycle.

[0050] During a normal charging cycle, the duty cycle is normally lower than the upper limit at the end of the constant current mode or thermal runaway starts. Normally, the duty cycle starts near the upper limit and steadily decreases.

[0051] The protection system in accordance with the present invention is not only configured to detect a thermal runaway condition but to also provide various responses to a thermal runaway condition depending on the conditions existing when the thermal runaway condition was detected. For example, upon detection of a thermal runaway the protection system may stop charging for a predetermined amount of time to allow the temperature of the components to cool off. The protection system may also force the battery charger into a maintenance state. Various exemplary responses are indicated in Table 1 below. The various stages are identified in Fig. 1B.

Table 1

Stage	Amps	Volts	Trigger	Response	Comment
Bulk	Not Applicable	< 12.2 volts	Time>Limit 1	Abort charging	Limit 1 typically a few to several hours depending on charge rate
Bulk	Not Applicable	< 14.2 volts	Time>Limit 2	Abort charging	Limit 2 typically several hours to 1 day depending on charge rate.
Constant Current	DutyLmt	< MaintVolt	DutyTrend>DtLimit	ReduceMaintVolt Continue di/dt	MaintVolt too high
Constant Current	>DutyLmt	≥ MaintVolt	DutyTrend>DtLimit	Cycle current on and off	Allow battery to cool during off time
Constant Current	<DutyLmt	~ MaintVolt	Time=Limit 3	Go to Maintenance State	Limit 3 - typically at least one day
End of Charge	Not Applicable	Not Applicable	DutyTrend>DtLimit	Go to Maintenance State	Charging nearly complete.

[0052] Obviously, many modifications and variations of the present invention are possible in light of the above teachings. Thus, it is to be understood that, within the scope of the appended claims, the invention may be practiced otherwise than as specifically described above.

Claims

1. A method for detecting anomalies in electrical charging parameters during charging of a battery, wherein said battery is charged according to a charging cycle comprising a constant/controlled current mode of operation, in which said battery is charged with a constant/controlled charging current, followed by a constant voltage mode of operation, in which said battery is charged with a constant charging voltage, and wherein said battery is charged according to a known charging characteristic, said charging characteristic corresponding to a condition free of anomalies and defining normal charging voltage and normal charging current curves, the method comprising the steps of:
 - (a) monitoring the charging voltage and the charging current supplied by a battery charger to a battery being charged during a constant/controlled current mode of operation and a constant voltage mode of operation;
 - (b) providing a signal representative of an anomaly when at least one of said charging voltage and said charging

current deviate from said normal charging voltage and normal charging current curves, said anomaly representing a possible thermal runaway condition;

characterized in that:

5
 10
 15
 20
 25
 30
 35
 40
 45
 50
 55

said battery is charged with a charging current having a variable duty cycle according to a known charging characteristic, said charging characteristic corresponding to a condition free of anomalies and defining a curve of a normal rate of change of the duty cycle of the charging current; and
 step (a) further includes monitoring the duty cycle of the charging current and tracking the rate of change in the duty cycle throughout the charging cycle;
 step (b) further includes providing a signal representative of an anomaly when the change in said duty cycle of said charging current deviates, during the constant/controlled current mode of operation, from said curve of a normal rate of change of the duty cycle of the charging current;

and by the step of:

(c) automatically forcing the battery charger into a predetermined state as a function of the detected anomaly in response to said signal and continuing charging under predetermined conditions.

2. The method as recited in claim 1, wherein said step (b) comprises: (b) providing a signal representative of an anomaly as a function of the charging current and the battery voltage during said constant/controlled current mode of operation.

3. The method as recited in claim 1, wherein said step (b) comprises: (b) providing a signal representative of an anomaly as a function of the amount of time required for the battery to reach a predetermined voltage during said constant/controlled current mode of operation.

4. The method as recited in claim 1, wherein said step (b) comprises: (b) providing a signal representative of an anomaly as a function of the actual charging current value required for the battery to reach a predetermined voltage during said constant/controlled current mode of operation.

5. The method as recited in claim 1, wherein said step (b) comprises: (b) providing a signal representative of an anomaly in said constant voltage mode of operation as a function of the duty cycle of said charging current.

6. The method as recited in claim 1, wherein said step (b) comprises: (b) providing a signal representative of an anomaly as a function of the battery voltage during said constant/controlled current mode of operation.

7. A battery charger comprising:

a charging circuit configured for charging a battery according to a charging cycle comprising a constant/controlled current mode of operation, in which said battery is charged with a constant/controlled charging current, followed by a constant voltage mode of operation, in which said battery is charged with a constant charging voltage, and

according to a known charging characteristic, said charging characteristic corresponding to a condition free of anomalies and defining normal charging voltage and normal charging current curves; and one or more monitoring devices configured for monitoring both the charging voltage and the charging current supplied by the battery charger to a battery under charge during a constant/controlled current mode of operation and a constant voltage mode of operation;

wherein said charging circuit is further configured to provide a signal representative of an anomaly when at least one of said charging voltage and said charging current deviate from said normal charging voltage and normal charging current curves, said anomaly representing a possible thermal runaway condition;

characterized in that

said charging circuit is further configured to charge the battery with a charging current having a variable duty cycle according to a known charging characteristic, said charging characteristic corresponding to a condition free of anomalies and defining a curve of a normal rate of change of the duty cycle of the charging current; and the battery charger further includes one or more monitoring devices configured for monitoring the duty cycle of a charging current and for tracking the rate of change in the duty cycle throughout a charging cycle; and

the charging circuit is further configured to provide a signal representative of an anomaly when the change in said duty cycle of said charging current deviates, during the constant/controlled current mode of operation, from said curve of a normal rate of change of the duty cycle of the charging current; and
 the charging circuit is further configured to automatically force the battery charger into a predetermined state as a function of the detected anomaly in response to said signal and continue charging under predetermined conditions.

8. The battery charger as recited in claim 7, wherein said charging circuit is configured to provide a signal representative of an anomaly as a function of the charging current and the battery voltage during said constant/controlled current mode of operation.
9. The battery charger as recited in claim 7, wherein said charging circuit is configured to provide a signal representative of an anomaly as a function of the amount of time required for the battery to reach a predetermined voltage during said constant/controlled current mode of operation.
10. The battery charger as recited in claim 7, wherein said charging circuit is configured to provide a signal representative of an anomaly as a function of the actual charging current value required for the battery to reach a predetermined voltage during said constant/controlled current mode of operation.
11. The battery charger as recited in claim 7, wherein said charging circuit is further configured to provide a signal representative of an anomaly in a constant voltage mode of operation as a function of one or more electrical charging parameters.
12. The battery charger as recited in claim 7, wherein said charging circuit is configured to track the duty cycle of said charging current in said constant voltage mode of operation and provide a signal representative of an anomaly in said constant voltage mode of operation as a function of the duty cycle of said charging current.

Patentansprüche

1. Verfahren zum Erkennen von Anomalien bei elektrischen Ladeparametern während des Ladens einer Batterie, wobei die Batterie nach einem Ladezyklus geladen wird, der Folgendes umfasst:

eine Betriebsart mit konstanter/kontrollierter Stromstärke, bei der die Batterie mit einem konstanten/kontrollierten Ladestrom geladen wird,
 gefolgt von einer Betriebsart mit konstanter Spannung, bei der die Batterie mit einer konstanten Ladespannung geladen wird,
 und wobei die Batterie nach einer bekannten Ladecharakteristik geladen wird, wobei die Ladecharakteristik einem Zustand entspricht, der frei von Anomalien ist, und Kurven für normale Ladespannung und normalen Ladestrom definiert,
 wobei das Verfahren die folgenden Schritte umfasst:

- (a) Überwachen der Ladespannung und des Ladestroms, die einer zu ladenden Batterie von einem Batterie-ladegerät während einer Betriebsart mit konstanter/kontrollierter Stromstärke und einer Betriebsart mit konstanter Spannung zugeführt werden;
- (b) Bereitstellen eines Signals für eine Anomalie, wenn mindestens eines von der Ladespannung und der Ladestromstärke von den normalen Ladespannungs- und Ladestromkurven abweicht, wobei die Anomalie einen Zustand eines möglichen thermischen Durchgehens repräsentiert;

dadurch gekennzeichnet, dass:

die Batterie mit einem Ladestrom mit variablem Arbeitszyklus nach einer bekannten Ladecharakteristik geladen wird, wobei die Ladecharakteristik einem Zustand entspricht, der frei von Anomalien ist, und eine Kurve für eine normale Änderungsgeschwindigkeit des Arbeitszyklus des Ladestroms definiert; und Schritt (a) ferner das Überwachen des Arbeitszyklus des Ladestroms und das Verfolgen der Änderungsgeschwindigkeit in dem Arbeitszyklus während des Ladezyklus umfasst; Schritt (b) ferner das Bereitstellen eines Signals für eine Anomalie umfasst, wenn die Änderung in dem Arbeitszyklus des Ladestroms während der Betriebsart mit konstanter/kontrollierter Stromstärke von der

Kurve einer normalen Änderungsgeschwindigkeit des Arbeitszyklus des Ladestroms abweicht;

und **gekennzeichnet durch** den folgenden Schritt:

- 5 (c) automatisches Zwingen des Batterieladegeräts in einen vorbestimmten Zustand als Funktion der erkannten Anomalie in Reaktion auf das Signal und Fortsetzen des Ladens unter vorbestimmten Bedingungen.
- 10 2. Verfahren nach Anspruch 1, wobei Schritt (b) Folgendes umfasst: (b) Bereitstellen eines Signals für eine Anomalie als Funktion des Ladestroms und der Batteriespannung während der Betriebsart mit konstanter/kontrollierter Stromstärke.
- 15 3. Verfahren nach Anspruch 1, wobei Schritt (b) Folgendes umfasst: (b) Bereitstellen eines Signals für eine Anomalie als Funktion der Zeit, die eine Batterie braucht, um während der Betriebsart mit konstanter/kontrollierter Stromstärke eine vorbestimmte Spannung zu erreichen.
- 20 4. Verfahren nach Anspruch 1, wobei Schritt (b) Folgendes umfasst: (b) Bereitstellen eines Signals für eine Anomalie als Funktion des tatsächlichen Ladestroms-Wertes, der erforderlich ist, damit die Batterie während der Betriebsart mit konstanter/kontrollierter Stromstärke eine vorbestimmte Spannung erreicht.
- 25 5. Verfahren nach Anspruch 1, wobei Schritt (b) Folgendes umfasst: (b) Bereitstellen eines Signals für eine Anomalie in der Betriebsart mit konstanter Spannung als Funktion des Arbeitszyklus des Ladestroms.
6. Verfahren nach Anspruch 1, wobei Schritt (b) Folgendes umfasst: (b) Bereitstellen eines Signals für eine Anomalie als Funktion der Batteriespannung während der Betriebsart mit konstanter/kontrollierter Stromstärke.
7. Batterieladegerät, das Folgendes aufweist:
- eine Ladeschaltung, die dazu ausgelegt ist, eine Batterie zu laden nach einem Ladezyklus mit
- 30 einer Betriebsart mit konstanter/kontrollierter Stromstärke, in der die Batterie mit einem konstanten/kontrollierten Ladestrom geladen wird, gefolgt von einer Betriebsart mit konstanter Spannung, in der die Batterie mit einer konstanten Ladespannung geladen wird, und nach einer bekannten Ladecharakteristik, wobei die Ladecharakteristik einem Zustand entspricht, der frei von Anomalien ist, und Kurven für eine normale Ladespannung und einen normalen Ladestrom definiert; und
- 35 eine oder mehrere Überwachungsvorrichtungen, die dazu ausgelegt sind, sowohl die Ladespannung als auch den Ladestrom zu überwachen, die einer zu ladenden Batterie von dem Ladegerät während einer Betriebsart mit konstanter/kontrollierter Stromstärke und einer Betriebsart mit konstanter Spannung zugeführt werden; wobei die Ladeschaltung ferner dazu ausgelegt ist, ein Signal für eine Anomalie bereitzustellen, wenn mindestens eines von der Ladespannung und der Ladestromstärke von den Kurven für eine normale Ladespannung und eine normale Ladestromstärke abweicht, wobei die Anomalie einen Zustand eines möglichen thermischen Durchgehens repräsentiert;
- 40 **dadurch gekennzeichnet, dass** die Ladeschaltung ferner dazu ausgelegt ist, die Batterie mit einem Ladestrom mit einem variablen Arbeitszyklus nach einer bekannten Ladecharakteristik zu laden, wobei die Ladecharakteristik einem Zustand entspricht, der frei von Anomalien ist, und eine Kurve einer normalen Änderungsgeschwindigkeit des Arbeitszyklus des Ladestroms definiert; und
- 45 das Batterieladegerät ferner eine oder mehrere Überwachungsvorrichtungen aufweist, die dazu ausgelegt sind, den Arbeitszyklus eines Ladestroms zu überwachen und die Änderungsgeschwindigkeit in dem Arbeitszyklus während eines Ladezyklus zu überwachen; und die Ladeschaltung ferner dazu ausgelegt ist, ein Signal für eine Anomalie bereitzustellen, wenn die Änderung im Arbeitszyklus des Ladestroms während der Betriebsart mit konstanter/kontrollierter Stromstärke von der Kurve einer normalen Änderungsgeschwindigkeit des Arbeitszyklus des Ladestroms abweicht; und
- 50 die Ladeschaltung ferner dazu ausgelegt ist, das Batterieladegerät automatisch in einen vorbestimmten Zustand als Funktion der erkannten Anomalie in Reaktion auf das Signal zu zwingen und das Laden unter vorbestimmten Bedingungen fortzusetzen.
- 55 8. Batterieladegerät nach Anspruch 7, wobei die Ladeschaltung dazu ausgelegt ist, ein Signal für eine Anomalie als

Funktion des Ladestroms und der Batteriespannung während der Betriebsart mit konstanter/kontrollierter Stromstärke bereitzustellen.

- 5
9. Batterieladegerät nach Anspruch 7, wobei die Ladeschaltung dazu ausgelegt ist, ein Signal für eine Anomalie als Funktion der Zeit bereitzustellen, die die Batterie braucht, um während der Betriebsart mit konstanter/kontrollierter Stromstärke eine vorbestimmte Spannung zu erreichen.
- 10
10. Batterieladegerät nach Anspruch 7, wobei die Ladeschaltung dazu ausgelegt ist, ein Signal für eine Anomalie als Funktion des tatsächlichen Ladestroms-Wertes bereitzustellen, der erforderlich ist, damit die Batterie während der Betriebsart mit konstanter/kontrollierter Stromstärke eine vorbestimmte Spannung erreicht.
- 15
11. Batterieladegerät nach Anspruch 7, wobei die Ladeschaltung ferner dazu ausgelegt ist, ein Signal für eine Anomalie in einer Betriebsart mit konstanter Spannung als Funktion eines oder mehrerer elektrischer Ladeparameter bereitzustellen.
- 20
12. Batterieladegerät nach Anspruch 7, wobei die Ladeschaltung dazu ausgelegt ist, den Arbeitszyklus des Ladestroms in der Betriebsart mit konstanter Spannung zu verfolgen und ein Signal für eine Anomalie in der Betriebsart mit konstanter Spannung als Funktion des Arbeitszyklus des Ladestroms bereitzustellen.

Revendications

- 25
1. Procédé pour détecter des anomalies dans des paramètres de charge électrique pendant la charge d'une batterie, dans lequel ladite batterie est chargée en accord avec un cycle de charge comprenant un mode de fonctionnement à courant constant/contrôlé, dans lequel ladite batterie est chargée avec un courant de charge constant/contrôlé, suivi d'un mode de fonctionnement à voltage constant, dans lequel ladite batterie est chargée avec un voltage de charge constant, et dans lequel ladite batterie est chargée en accord avec une caractéristique de charge connue, ladite caractéristique de charge correspondant à une condition exempte d'anomalies et définissant des courbes de voltage de charge normale et de courant de charge normale, le procédé comprenant les étapes consistant à :
- 30

- 35
- (a) surveiller le voltage de charge et le courant de charge fournis par un chargeur de batterie à une batterie qui est chargée pendant un mode de fonctionnement à courant constant/contrôlé et un mode de fonctionnement à voltage constant ;
- (b) fournir un signal représentatif d'une anomalie quand au moins un parmi ledit voltage de charge et ledit courant de charge dévie desdites courbes de voltage de charge normale et de courant de charge normale, ladite anomalie représentant une condition éventuelle de claquage thermique ;
- 40

caractérisé en ce que :

- 45
- ladite batterie est chargée avec un courant de charge ayant un cycle de service variable en accord avec une caractéristique de charge connue, ladite caractéristique de charge correspondant à une condition exempte d'anomalies et définissant une courbe à taux de changement normal du cycle de service du courant de charge ; et l'étape (a) inclut encore la surveillance du cycle de service du courant de charge et le suivi du taux de changement dans le cycle de service pendant tout le cycle de charge ; l'étape (b) inclut encore la fourniture d'un signal représentatif d'une anomalie quand le changement dudit cycle de service dudit courant de charge dévie, pendant le mode de fonctionnement à courant constant/contrôlé, vis-à-vis de ladite courbe à taux de changement normal du cycle de service du courant de charge ;
- 50

et comprenant l'étape consistant à :

- 55
- (c) forcer automatiquement le chargeur de batterie vers un état prédéterminé en tant que fonction de l'anomalie détectée en réponse audit signal, et continuer la charge sous des conditions prédéterminées.

2. Procédé selon la revendication 1, dans lequel ladite étape (b) comprend l'opération consistant à : (b) fournir un signal représentatif d'une anomalie en tant que fonction du courant de charge et du voltage de batterie pendant

ledit mode de fonctionnement à courant constant/contrôlé.

- 5
3. Procédé selon la revendication 1, dans lequel ladite étape (b) comprend l'opération consistant à : (b) fournir un signal représentatif d'une anomalie en tant que fonction du temps nécessaire pour que la batterie atteigne un voltage prédéterminé pendant ledit mode de fonctionnement à courant constant/contrôlé.
- 10
4. Procédé selon la revendication 1, dans lequel ladite étape (b) comprend l'opération consistant à : (b) fournir un signal représentatif d'une anomalie en tant que fonction de la valeur actuelle du courant de charge nécessaire pour que la batterie atteigne un voltage prédéterminé pendant ledit mode de fonctionnement à courant constant/contrôlé.
- 15
5. Procédé selon la revendication 1, dans lequel ladite étape (b) comprend l'opération consistant à : (b) fournir un signal représentatif d'une anomalie dans ledit mode de fonctionnement à voltage constant en tant que fonction du cycle de service dudit courant de charge.
- 20
6. Procédé selon la revendication 1, dans lequel ladite étape (b) comprend l'opération consistant à : (b) fournir un signal représentatif d'une anomalie en tant que fonction du voltage de batterie pendant ledit mode de fonctionnement à courant constant/contrôlé.
- 25
7. Chargeur de batterie comprenant :
- 30
- un circuit de charge configuré pour charger une batterie en accord avec un cycle de charge comprenant un mode de fonctionnement à courant constant/contrôlé dans lequel ladite batterie est chargée avec un courant de charge constant/contrôlé,
- 35
- suivi d'un mode de fonctionnement à voltage constant dans lequel ladite batterie est chargée avec un voltage de charge constant, et en accord avec une caractéristique de charge connue, ladite caractéristique de charge correspondant à une condition exempte d'anomalies et définissant des courbes de voltage de charge normale et de courant de charge normale; et
- 40
- un ou plusieurs dispositifs de surveillance configurés pour surveiller à la fois le voltage de charge et le courant de charge fournis par le chargeur de batterie à une batterie en cours de charge pendant un mode de fonctionnement à courant constant/contrôlé et un mode de fonctionnement à voltage constant ; dans lequel ledit circuit de charge est en outre configuré pour fournir un signal représentatif d'une anomalie quand l'un au moins parmi ledit voltage de charge et ledit courant de charge dévie par rapport auxdites courbes de voltage de charge normale et de courant de charge normale, ladite anomalie représentant une condition éventuelle de claquage thermique ;
- 45
- caractérisé en ce que** ledit circuit de charge est en outre configuré pour charger la batterie avec un courant de charge ayant un cycle de service variable en accord avec une caractéristique de charge connue, ladite caractéristique de charge correspondant à une condition exempte d'anomalies et définissant une courbe à taux de changement normal du cycle de service du courant de charge ; et le chargeur de batterie inclut encore un ou plusieurs dispositifs de surveillance configurés pour surveiller le cycle de service d'un courant de charge et pour suivre le taux de changement du cycle de service pendant tout un cycle de charge ; et
- 50
- le circuit de charge est encore configuré pour fournir un signal représentatif d'une anomalie quand le changement dudit cycle de service dudit courant de charge dévie, pendant le mode de fonctionnement à courant constant/contrôlé, depuis ladite courbe à taux de changement normal du cycle de service du courant de charge ; et le circuit de charge est encore configuré pour forcer automatiquement le chargeur de batterie dans un état prédéterminé en tant que fonction de l'anomalie détectée en réponse audit signal et pour continuer la charge sous des conditions prédéterminées.
- 55
8. Chargeur de batterie selon la revendication 7, dans lequel ledit circuit de charge est configuré pour fournir un signal représentatif d'une anomalie en tant que fonction du courant de charge et du voltage de batterie pendant ledit mode de fonctionnement à courant constant/contrôlé.
9. Chargeur de batterie selon la revendication 7, dans lequel ledit circuit de charge est configuré pour fournir un signal représentatif d'une anomalie en tant que fonction du temps nécessaire pour que la batterie atteigne un voltage prédéterminé pendant ledit mode de fonctionnement à courant constant/contrôlé.

EP 2 255 428 B1

10. Chargeur de batterie selon la revendication 7, dans lequel ledit circuit de charge est configuré pour fournir un signal représentatif d'une anomalie en tant que fonction de la valeur actuelle du courant de charge nécessaire pour que la batterie atteigne un voltage prédéterminé pendant ledit mode de fonctionnement à courant constant/contrôlé.

5 11. Chargeur de batterie selon la revendication 7, dans lequel ledit circuit de charge est encore configuré pour fournir un signal représentatif d'une anomalie dans un mode de fonctionnement à voltage constant en tant que fonction d'un ou plusieurs paramètres de charge électrique.

10 12. Chargeur de batterie selon la revendication 7, dans lequel ledit circuit de charge est configuré pour suivre le cycle de service dudit courant de charge dans ledit mode de fonctionnement à voltage constant et fournir un signal représentatif d'une anomalie dans ledit mode de fonctionnement à voltage constant en tant que fonction du cycle de service dudit courant de charge.

15

20

25

30

35

40

45

50

55

DieHard 71227 (Deep Cycle, 15A) on West Marine SeaVolt Deep Cycle 75

Discharge A·h: 71.25 before charge; 67.53 after charge
 93.152 A·h delivered during charge (30.7% overcharge)
 OCV = 11.942V before charge

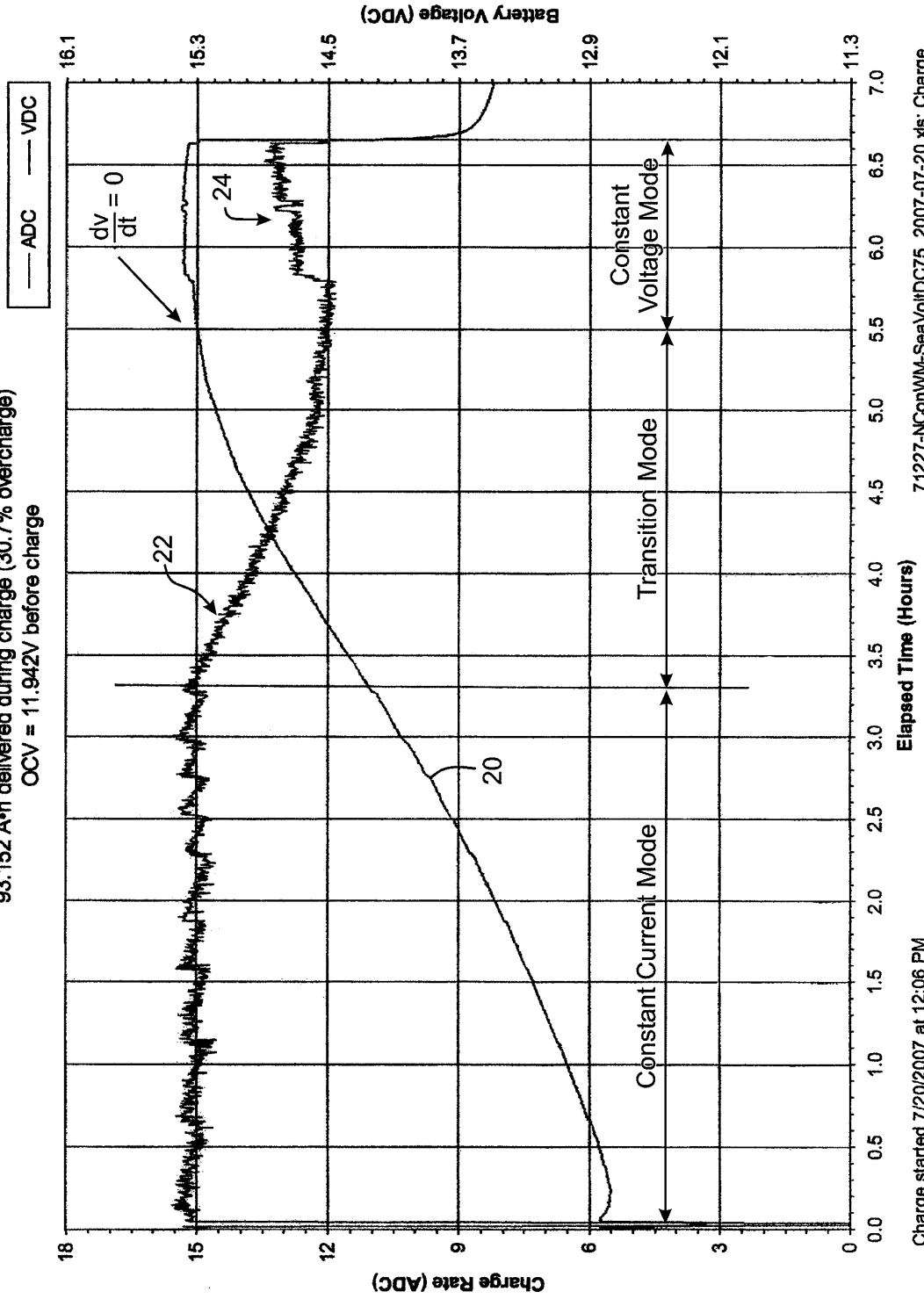

Charge started 7/20/2007 at 12:06 PM
 71227-NConWM-SeaVoltDC75_2007-07-20.xls: Charge

Fig. 1A

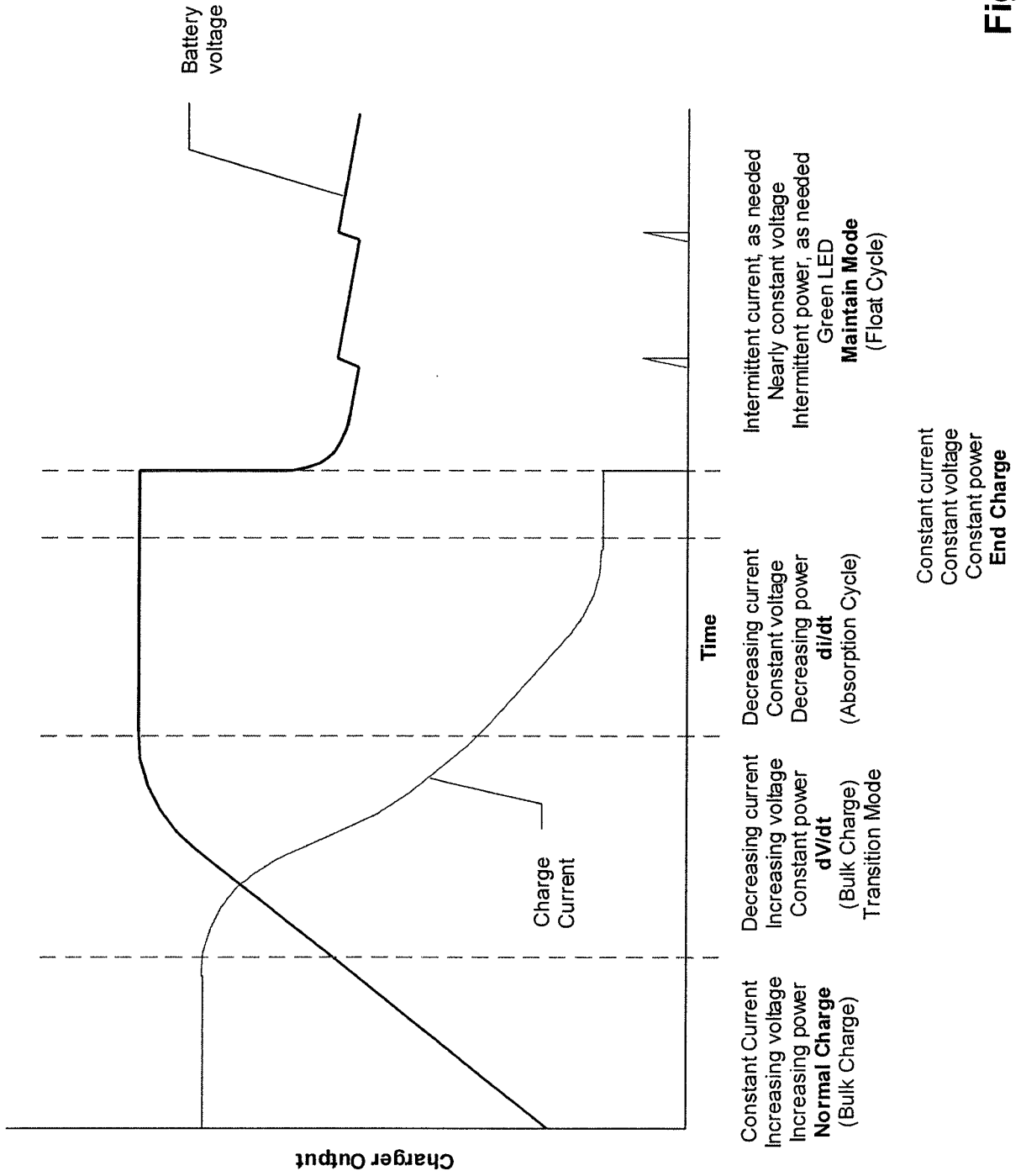

Fig. 1B

Thermal Runaway Protection Code in Main Charging Loop

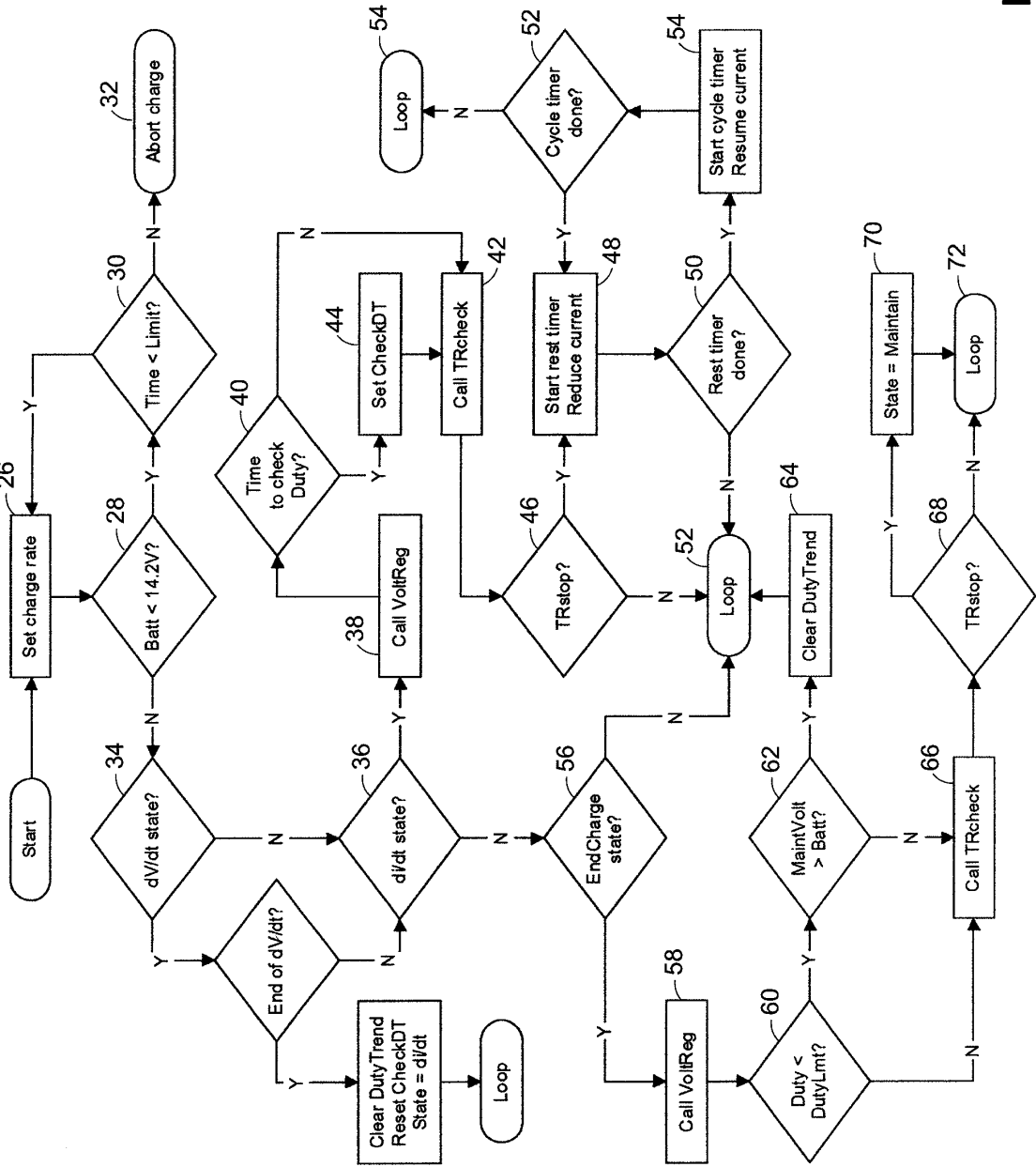

Fig. 2

Thermal Runaway Protection Code in Voltage Regulation Routine

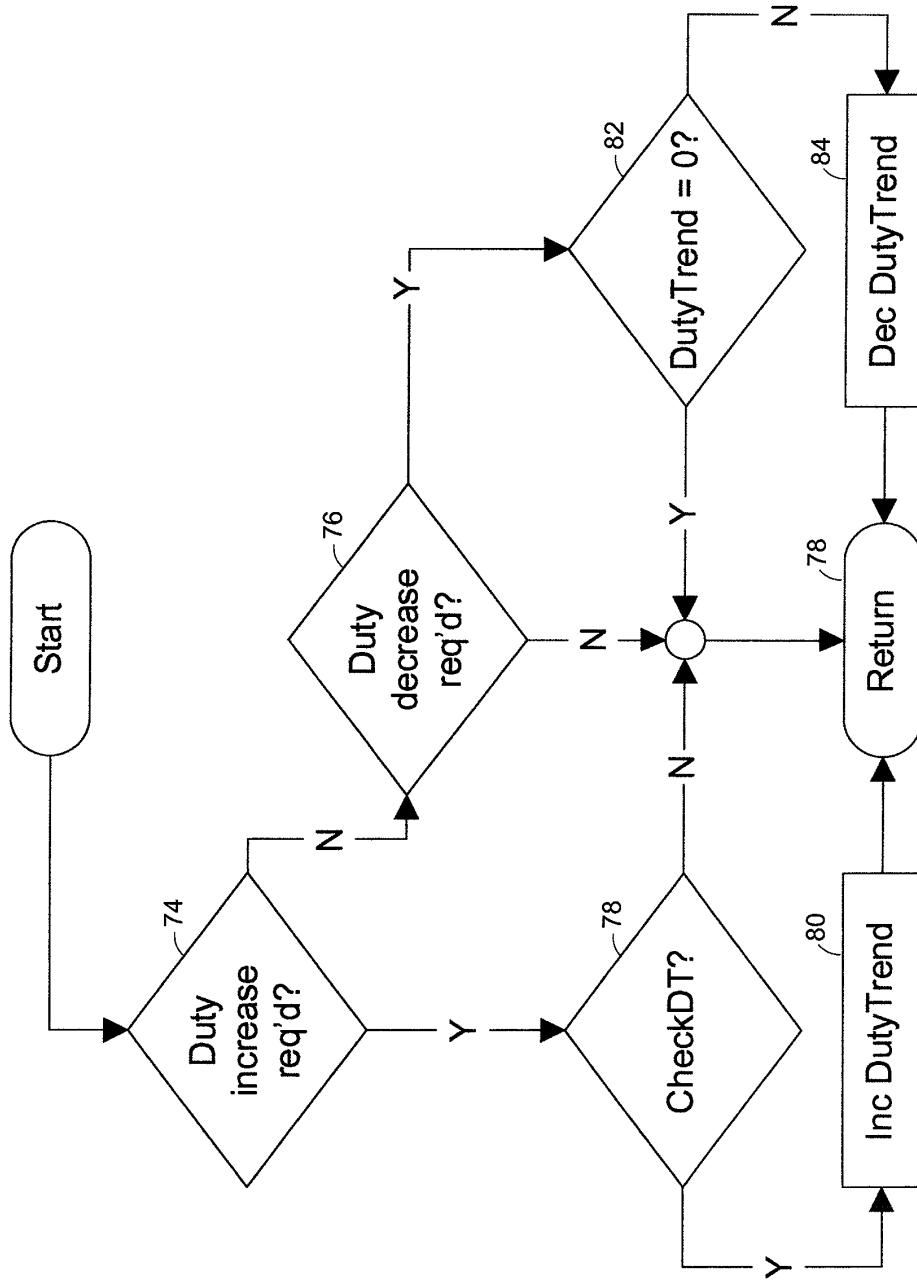

Fig. 3

Thermal Runaway Protection TRcheck Routine

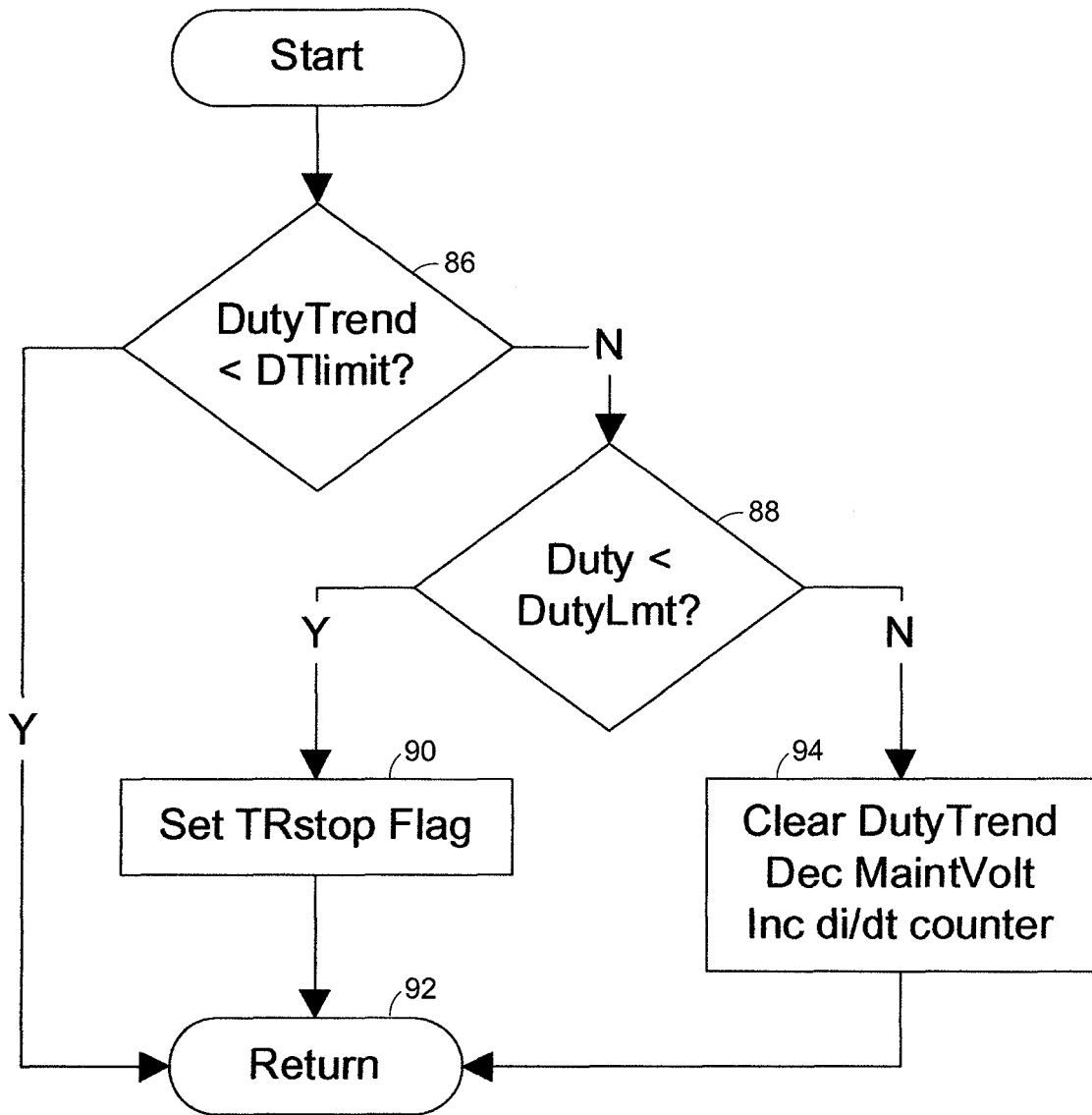

Fig. 4

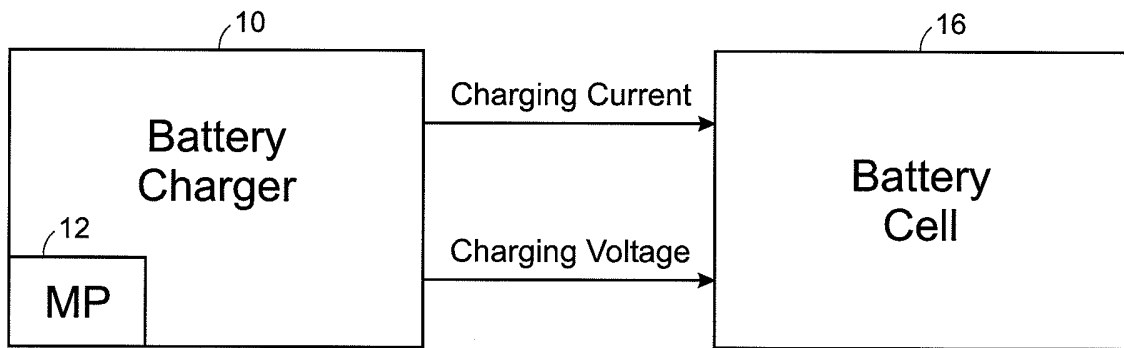

Fig. 5

REFERENCES CITED IN THE DESCRIPTION

This list of references cited by the applicant is for the reader's convenience only. It does not form part of the European patent document. Even though great care has been taken in compiling the references, errors or omissions cannot be excluded and the EPO disclaims all liability in this regard.

Patent documents cited in the description

- US 5214370 A [0005]
- US 6020721 A [0005]
- US 20070018780 A1 [0005]
- WO 2004097956 A2 [0005]
- US 2002109506 A1 [0014]
- JP 2003153436 A [0015]
- US 11487071 B [0023]
- US 20070114970 A1 [0023]
- US 20050088144 A1 [0031]