

(19)



(11)

EP 2 284 351 B1

(12)

EUROPEAN PATENT SPECIFICATION

(45) Date of publication and mention of the grant of the patent:

30.03.2016 Bulletin 2016/13

(51) Int Cl.:

E06B 9/06 (2006.01)

E06B 9/262 (2006.01)

(21) Application number: **08761550.6**

(86) International application number:

PCT/ES2008/000304

(22) Date of filing: **02.05.2008**

(87) International publication number:

WO 2009/133213 (05.11.2009 Gazette 2009/45)

(54) **DOUBLE-PANEL QUICK-OPENING DOOR**

SCHNELL ÖFFNENDE TÜR MIT ZWEI VORHÄNGEN

PORTE À OUVERTURE RAPIDE À DOUBLE RIDEAU

(84) Designated Contracting States:

**AT BE BG CH CY CZ DE DK EE ES FI FR GB GR
HR HU IE IS IT LI LT LU LV MC MT NL NO PL PT
RO SE SI SK TR**

(74) Representative: **Maldonado Jordan, Julia**

**Linares, 7 - 3
46018 Valencia (ES)**

(43) Date of publication of application:

16.02.2011 Bulletin 2011/07

(56) References cited:

EP-A1- 1 045 110 EP-A1- 1 174 063

EP-A2- 0 953 306 EP-A2- 1 475 508

WO-A1-97/42391 WO-A1-2007/107609

CH-A5- 663 984 DE-A1- 3 248 083

(73) Proprietor: **Amiserru, S.L.**

08190 Sant Cugat del Vallés, Barcelona (ES)

(72) Inventor: **IGLESIAS BALLESTER, Miguel Angel**

08190 Sant Cugat del Vallés, Barcelona (ES)

EP 2 284 351 B1

Note: Within nine months of the publication of the mention of the grant of the European patent in the European Patent Bulletin, any person may give notice to the European Patent Office of opposition to that patent, in accordance with the Implementing Regulations. Notice of opposition shall not be deemed to have been filed until the opposition fee has been paid. (Art. 99(1) European Patent Convention).

Description

Object of the Invention

[0001] This present invention relates to a double panel quick-opening door of the type that has a frame formed by two vertical posts and an upper cross-piece, two flexible panels suspended from the upper cross-piece of the frame, guided on the vertical posts of the frame and connected to each other by some intermediary elements and some actuation means for the movement of the flexible panels between an unfolded closure position and an upper folded open position.

Background to the Invention

[0002] As a background to this invention the patent WO 2007/107609 of the same owner must be highlighted in which a quick opening double canvas door is described, which includes two closure canvases or flexible sheets, appreciably parallel in a door closure position, suspended from the upper cross-piece of the frame and connected to each other by some cross intermediary members or profiles that are fixed at their ends, with the possibility of vertical movement, arranged over the vertical posts of the frame.

[0003] The intermediary profile that takes the lower position or another upper position is moved by the stops that are fixed on the intermediary strips or flat belts that pass through some openings made in the intermediary profiles and which are fixed at their upper ends with the respective roller drums, connected to a turning axle, actuated by a motor element.

[0004] One of the disadvantages of this actioning element is that the weight that it transfers directly onto the upper actioning axle, which can bring about, especially with large sized doors, is flexions and cavitations of the stated axle, when said axle and actioning motor are working under unfavourable conditions.

[0005] On the other hand, the flattened arrangement of the strips or actioning belts determines that the windows or openings made in the intermediary profiles for the passage of said strips have an elongated arrangement, whether it is rectangular or in the shape of a buttonhole opening.

[0006] These elongated windows mean a weakening of the section of the intermediary profiles and with the consequent reduction of their resistance.

[0007] One of the disadvantages, determined by the elongated arrangement of these windows, is that they must be made by means of milling, which is a slow machining process and has an effect on the final cost of the door.

[0008] In these types of doors the intermediary profiles fixed to the panels are moved vertically by the action of the belts, which means that they knock against each other and this brings about a banging on the upper cross-piece of the frame, with the consequent risk of deterioration of

the intermediary profiles themselves and the upper cross-piece.

[0009] One additional problem of these types of doors is the linking of the side edges of the panels or canvases with the vertical posts of the frame, which brings about significant deterioration by friction of the closure panels.

Description of the Invention

[0010] The double panel quick-opening door object of this invention presents some construction peculiarities aimed at solving the previously stated problems, specifically in that which refers to the loads transferred that act on the actioning axle, the banging produced by the intermediary profiles on one another and with the upper cross-piece during the opening of the door, and the machining of the intermediary profiles, the elongated windows for the passage of the belts or flat tapes, which weaken said intermediary profiles.

[0011] The solution proposed consists of the use of some actioning devices that do not use roller drums, or an upper axle that works with roller drums on which the loads are transferred, with which the stated problems of flexions and cavitations of the axle are avoided, likewise the flat strips or belts by some resistant cords or cables, preferably having a circular section, that enable the actioning mechanism that is stated below to be used. Another of the aims of the invention is to eliminate the intermediary horizontal profiles that are normally used and providing some opposing side devices for the fixing on the two door closure panels, and to guarantee a smooth and correct movement of the panels on the vertical posts of the frame, without said panels suffering any appreciable deterioration when in use.

[0012] In accordance with the invention, the actioning means include some resistant cords or cables, preferably having a circular section, that are fixed by one of the ends to some stops that action some intermediary elements fixed to the closure panels, additionally including said actioning means: Some pulleys on a horizontal axis distributed on the upper cross-piece for support and change of vertical-horizontal direction of the respective actioning cords of the intermediary elements, an end guide or pulley for the support of the cords and their re-direction towards a zone in which the strap of the cords forms a simple or multiple loop together with a fixed end strap of the cords; and some means of actioning that act on the middle area of the loop formed by the cords, bringing about a variation in the length of said loop and consequently the opening or closing of the door.

[0013] To prevent the accidental dismantling of the actioning cords whilst they are working the fitting of some lateral stop elements has been provisioned so as to guide them.

[0014] In the loop formed by the cords and the actioning means of same they can be located in one of the vertical posts of the frame, even though their placement in some other position cannot be ruled out, for example out of the

said vertical post.

[0015] The assembly of the stated pulleys on the upper cross-piece of the frame does not pose any constructional problems, as said upper cross-piece does not turn as the previously used axle did, but it is a fixed element, that can be suitably designed and sized to support the stresses transferred by the cords to the pulleys, having envisaged in a specific embodiment that the said upper cross-piece has a section like that of an inverted 'U', or another shape that makes the assembly easy for the axle of the pulleys on the lateral wings of said upper cross-piece, allowing the passage of the cords, through the lower zone of the cross-piece, towards the respective re-directing pulleys, likewise all of the mechanism can be suitably protected by said upper cross-piece.

[0016] On the other hand the definition of a loop by the cords in the actioning area of the actuation means allows the use of some actuation means whose travel is, depending on the number of loops, a fraction of the travel of the intermediary actuation elements by their respective cords or cables between their open or closed positions of the door.

[0017] In one embodiment of the invention, the actuation means of the cords or cables are made up of a lineal movement mechanism that acts on a pulley assembled on the middle area of the loop, simple or multiple, defined by the actioning cords or cables.

[0018] In one embodiment of the invention the said actioning means additionally include a counterweight, connected to the lineal movement mechanism and that partially or fully compensates the weight of the door, working with said lineal movement mechanism of the door towards the open and closed positions.

[0019] In accordance with the invention the intermediary elements fixed to the closure panels are made up from some vertical alignments of elastic plugs with a low friction coefficient that have a vertical opening for the moving assembly, with low friction coefficient of the corresponding actioning cord or cable.

[0020] The elastic nature of the stated plugs allows them to absorb the impacts caused by the knocking when they reach the upper position during the opening of the door.

[0021] Another of the characteristics of the invention consists in that the elastic plugs have some means of magnetic attraction at their top and bottom ends, made from two magnets and a ferromagnetic piece embedded in said plug so as to prevent knocks, which will tend to keep them together as the said elastic plugs come into contact with each other during the opening of the door, preventing them from bouncing off because of the impact, taking their elastic nature into account.

[0022] The stated elastic plugs are joined by the opposing sides to the respective closure panels of the door by some means of fixing.

[0023] In one embodiment of the invention the means of fixing of the closure panels to the elastic plugs comprise some platens fixed to some inner flaps of the closure

panels and to the elastic plugs by means of screws, rivets, bolts or other similar devices.

[0024] According to the invention the door has some moveable means for the assembly of the side edges of the panels in respect of the vertical posts of the frame, said assembly devices having some vertically directed anti-friction panels and being able to protrude at the front from the opposing sides of the vertical posts, making up some means for the internal or external guiding of the closure panels of the door.

[0025] The moveable assembly devices additionally include some pairs of bearings that act on the inner face of the vertical posts of the frame and are fixed to the closure panels.

[0026] Each pair of bearings is arranged on a turning axis together with an assembled fixing platen, in such a way that it passes and with the possibility of vertical movement, in a vertical groove of the corresponding vertical post of the frame and fixed to the closure panels of the door.

[0027] In one embodiment of the invention, the fixing platens of the pairs of bearings are fixed to the door panels by some supports fixed to the stated bearing support platens and to the elastic plug support platens.

[0028] In one variation of the embodiment the fixing platens of the pairs of bearings are fixed to the closure panels by means of a tensor element that drives the fixing platens and the bearings in opposite directions. This tensor element brings about the tensioning of the fixing platens towards the bearings that are moved along the vertical posts of the frame during the opening and closing of the door.

[0029] In whichever case, the fixing platens of the bearings make a mechanical fusion of an appropriate section to bear a specific tension, appropriately calculated so that the door can work normally and taking the thrust communicated by the wind on the closure panels and that said platens break when the closure panels receive an upper thrust, for example as a result of a bang against the closure panels from a vehicle. In this case, the breakage of the fixing platens stops the fixing platens from transferring an excessive force onto the vertical posts and, the consequent significant deterioration of the door, in the event of an impact from a vehicle.

[0030] In order to make the assembly of the closure panels easier on the upper cross-piece, said upper cross-piece has some longitudinal channels in which some fixing cannulas are housed, fixed to the closure panels, and some flexible profiles of a self-lubricating and sliding material, intended to retain the fixing cannulas on the inside of the longitudinal channel of the upper cross-piece.

Description of the figures.

[0031] In order to complete the description that is being made and for the purpose of providing a better understanding of its characteristics, a set of drawings is attached to this present description in which the figures

being by way of illustration and are not by way of limitation on the invention, in which the following is shown:

Figure 1 shows a diagrammatic elevation front view of an example of an embodiment of the door in the closed position, and in which the hidden elements corresponding to the actioning devices of the closure panels have been shown with a dotted line.

Figure 2 shows a diagrammatic front elevation view of the door of the previous figure, during the initial opening of the door, in which the upper cross-piece of the frame has been sectioned through a vertical plane and the front closure panel has been removed so as to allow the actioning devices of the closure panels to be seen.

Figure 3 shows a schematic upper plan view of the actioning cords passing over the pulleys assembled on the upper cross-piece.

Figure 4 shows a front elevation view of the door with the upper cross-piece sectioned through a vertical plane, so as to allow a variation of an embodiment of the actioning devices of the door, housed on the inside, to be seen.

Figure 5 shows a detail of the profile of the assembly of one of the elastic plugs between two door closure panels.

Figure 6 shows a perspective detail of one of the elastic plugs, assembled on one of the actioning cords or cables and fitted with some magnetic attraction devices on the top and bottom ends.

Figure 7 shows an upper plan view of a lateral portion of the door, sectioned through a horizontal plane and in which the guide and assembly devices of the side edges of the closure panels can be seen on the vertical post of the frame corresponding to said side.

Figure 8 shows an exploded view in perspective of the fixing devices of one of the pairs of bearings on the door closure panels.

Figure 9 shows an upper plan view of a lateral portion of the door, sectioned through a horizontal plane and in which a variation of an embodiment of the guide and assembly devices of the side edges of the closure panels can be seen on the vertical post of the frame corresponding to said side, fitted in this case with a tensor mechanism.

Figure 10 shows an exploded view in perspective of the guide and fixing devices shown in figure 9.

Figure 11 shows a profile view of the upper cross-piece and the devices used for the fixing of the closure panels onto said upper cross-piece.

Preferred embodiment of the invention

[0032] As can be seen in the referenced figures the door has a perimeter frame made of two vertical posts (1) and an upper cross-piece (2) from which two closure panels (3) are suspended, made from a flexible material, being appreciably parallel and joined at differing heights

by some elastic plugs (4) which are vertically aligned, making up several rows.

[0033] Said elastic plugs (4) have a vertical opening (41) for the passage of some actioning cords (5) for each one of the vertical rows of elastic plugs (4).

[0034] The elastic plugs (4) have some magnetic attraction devices (6) at the upper and lower ends for the connection, as each one is placed on top of the next during the opening of the door, preventing the separation of each other on being knocked on the upward movement of the closure panels.

[0035] The actioning cords (5) are fitted with respective adjustable stops (51) fitted under each one of the elastic plugs of the respective vertical rows of plugs so as to be able to easily level the stretch that is making the traction on the entirety of the assembly.

[0036] The cords (5) go into the inside of the upper cross-piece (2) of the frame, which in this example of an embodiment has an inverted 'U' shape section and on the inside of which there are some pulleys (7) assembled onto which the action cords (5) are supported when a change of vertical-horizontal direction is made.

[0037] In the example shown the pulleys (7) have some lateral stops (8) to prevent the cords (5) from being able to accidentally come off of said pulleys (7), allowing the passage of the cords towards the corresponding row, both vertical and equally horizontal.

[0038] In the example of the embodiment shown in figures 1 to 3, the cords (5) pass horizontally on the inside of the upper cross-piece (2) towards a guide, represented in this example of the embodiment by an end pulley (7) and which redirects them towards a lower area, where the strap coming from the upper cross-piece and the fixed end strap of the cord (5) form a loop (5a).

[0039] There is a pulley (7a) onto the intermediate section of the loop (5a) that is connected to some actioning devices that bring about the vertical movement, A variation of the length of the loop (5a) and consequently the opening or closing of the door.

[0040] In the example shown in figures 1 and 2, the actioning device of the pulley (7a) includes a counter weight (91) that compensates to a lesser or greater degree for the weight of the door and it is fitted to a lineal movement mechanism (9), represented in this case by a double action hydraulic cylinder.

[0041] The stated lineal movement mechanism (9) is connected in a conventional manner with an external control; manual or automatic that activates fluid pressure feed circuit.

[0042] In figures 1 and 2 the actioning devices include a damper and deceleration device (92) of the counter weight (91) when it approaches the lower position, corresponding to the closed position of the door.

[0043] In figure 4 a variation of an embodiment can be seen of the door actioning devices, in which the lineal movement mechanism (9) is arranged horizontally on the inside of the upper cross-piece (2) and it acts simultaneously in opposite directions, by means of both pulleys

(7a) on two loops (5a) formed by the closure panels actioning cords (5). In this specific example the lineal movement mechanism (9) is made up of a screw (93) actuated by a motor (94) and which has two sections threaded in opposing directions that act on some pieces or carriages (95), pulley carriers (7a) which vary the length of the loops (5a), bringing about the raising or lowering of the closure panels (3).

[0044] As and how can be seen in figure 5 the means of fixing of the closure panels (3) to the elastic plugs (4) comprises some platens (10) fixed to some inner flaps (11) of the closure panels (3) and to the elastic plugs (4) by means of screws (12), rivets, bolts or other similar devices.

[0045] In the example shown said inner protrusions (11) have an arrangement in the form of a longitudinal bag or loop, for the housing of the platens (10).

[0046] The anti-friction panels (13) can be seen in figures 2 and 7 and which are connected to the vertical posts (1) of the frame and which make up some means for the vertical guiding of the side edges of the closure panels (3), without the latter suffering from any appreciable wear.

[0047] An example of an embodiment of the anchoring devices that move by the side edges of the closure panels (3) can be seen in figures 7 and 8 and which are made up from pairs of bearings (14) that work on the inner faces of the vertical posts (1) and which are fitted onto a turning axle (15), appropriately fixed to the bearings, together with a support platen (16) that exits through the groove (19) of the corresponding vertical post (1).

[0048] Said support platen (16) is fixed to the closure panels (3), and more specifically to the platens (10) by means of some supports (17) and some screws (18).

[0049] In the variation of the embodiment shown in figures 9 and 10 the pairs of bearings (14) are fixed to the closure panels (3) and more specifically to the platens (10) by means of a tensor mechanism. In this example of an embodiment the platen (16) is assembled in a way that it is passing through a support (17) and is moved towards the rear by the action of a spring (20) that acts with its ends against the stated support (17) and against a nut (21) that is tightened and is fitted to the rear end of the platen (16).

[0050] This tensor mechanism provides an adjustable tension for the platens (10) towards the bearings (14).

[0051] Additionally, it must be stated that the fixing platens (16) have a calculated section so as to bear the forces coming from the door under normal working and to support a specific tension of the closure panels (3), for example coming from the action of the wind, and to break when the closure panels (3) undergo excessive traction, for example coming from the impact of a vehicle onto the closure panels (3). Therefore, said fixing platens (16) act as mechanical fuses preventing the forces that are in excess of a pre-established value from being able to be transferred to the vertical posts (1) of the frame.

[0052] Figure 11 shows a detail of the fixing for the

closure panels (3) to the upper cross-piece (2), in which the said upper cross-piece (2) has some longitudinal channels (23) where some fixing cannulas (31) are housed, fixed to the closure panels (3) and some flexible profiles (32) of a self lubricating and sliding material, that keep the fixing cannulas (31) on the inside of the longitudinal channels (23) of the upper cross-piece.

[0053] Once having sufficiently described the nature of the invention, likewise having given an example of a preferred embodiment it is placed on record that the materials, shape, size and arrangement of the elements described can be modified provided that they do not mean an alteration of the basic essentials of the invention that are claimed below.

Claims

1. Double panel quick opening door, of the type that includes: A frame made up of two vertical posts (1) and an upper cross-piece (2), two flexible closure panels (3), suspended from the upper cross-piece (2) of the frame and joined to each other at different heights by some intermediary elements, some means of guiding the panels in the vertical posts of the frame and, some actioning devices for the closure panels (3) from an unfolded closed position to an upper folded open position; is **characterised in that** the actioning devices of the closure panels (3) include: some resistant and flexible cords or cables (5) fitted with some adjustable stops (51) for the vertical actioning of the intermediary elements which connect the closure panels to each other, some horizontal axis and free turning pulleys (7) which are assembled on the upper cross-piece (2) for the guiding of the differing (rows) vertical cords or cables towards a zone in which the strap of the cords (5) define a simple or multiple loop (5a) with the fixed end of the strap, and some means of actioning (9, 91), that act on the middle zone of the loops (5a) defined by the cords (5), bringing about a variation of the length of said loops (5a) and the opening or closing of the door.
2. A door, according to claim 1, **characterised in that** the intermediary elements fixed to the closure panels (3) are made up from some impact absorbing elastic plugs (4), which have a vertical opening (41) with a low friction coefficient for the passage of the corresponding actioning cord or cable (51).
3. A door, according to claim 2, **characterised in that** the elastic plugs (4) define at least one vertical alignment.
4. Door, according to either of the claims 2 or 3, **characterised in that** the elastic plugs (4) have some means of magnetic attraction (6) at the upper and

lower ends, which are intended to keep them joined when said elastic plugs (4) make contact with each other during the door opening.

5. Door, according to any of the claims 2 to 4, **characterised in that** the elastic plugs (4) are joined to the respective closure panels (3) of the door by some fixing devices.
6. Door, according to claim 5, **characterised in that** the fixing devices of the elastic plugs (4), form some platens (10) fixed to some inner protrusions (11) of the closure panels (3) and the elastic plugs (4).
7. Door, according to claim 6, **characterised in that** the platens (10) are fixed to the inner protrusions (11) of the closure panels (3) and the elastic plugs (4) by means of screws, rivets, bolts or some other similar means.
8. Door, according to any of the above claims, **characterised in that** the actioning devices of the cords or cables (5) are formed by a lineal movement mechanism (9) that acts, on at least one pulley (7a) assembled on the loops (5a) defined by the actioning cords or cables (5).
9. Door, according to claim 8, **characterised in that** the actioning devices of the cords includes a counter weight (91) connected to the lineal movement mechanism (9) and which partially or fully counter balances the weight of the door, and which can enable the opening of same in the event of an electrical supply failure.
10. Door, according to claim 9, **characterised in that** the actioning devices include a damper and deceleration device (92) of the counter weight when it approaches the lower position, corresponding to the closed position of the door.
11. Door, according to any of the previously stated claims, **characterised in that** the vertical posts (1) of the frame include some anti-friction panels (13), vertically orientated, which define some means for the internal and external guiding of the closure panels (3) of the door.
12. Door, according to any of the above claims, **characterised in that** the moveable assembly devices of the side edges of the closure panels (3) in regard to the vertical posts (1) includes some pairs of bearings (14) that act on the inner face of the vertical posts (1), and which are fixed to the closure panels (3).
13. Door, according to claim 12, **characterised in that** the pairs of bearings (14) are assembled on a turning axis (15) jointly with an assembled fixing platen (16),

in such a way that it passes through and with the possibility of vertical movement, in a vertical groove (19) of the corresponding vertical post (1) of the frame and fixed to the closure panels (3) of the door.

14. Door, according to claim 13, **characterised in that** the fixing platen (16) of the pairs of bearings (14) are fixed to the closure panels (3) by means of some supports (17) fixed to the platens (10).
15. Door, according to claim 14, **characterised in that** the fixing platens (16) of the pairs of bearings (14) are fixed to the closure panels (3) by means of a tensor element that drives the fixing platens (16) and the bearings (14) in opposite directions.
16. Door, according to any of the claims 13, 14 or 15, **characterised in that** the fixing platen (16) defines a mechanical fuse with an appropriate section so as to bear a specific tension.
17. Door, according to any of the previous claims, **characterised in that** the pulleys (7) have some side stops (8) to prevent the cables from exiting the guides, and allow the passage of the horizontal cables (5) towards the corresponding vertical row.
18. Door, according to any of the above claims, **characterised in that** the upper cross-piece (2) has some longitudinal channels (23) in which some fixing cannulas (31) are housed, fixed to the closure panels (3), and some flexible profiles (32) of a self-lubricating and sliding material, for the retention of the fixing cannulas (31) on the inside of the longitudinal channels of the upper cross-piece.

Patentansprüche

1. Schnell öffnende Tor mit doppeltem Paneel, das folgende Elemente umfasst: einen Rahmen, bestehend aus zwei vertikalen Pfosten (1); einen oberen Querträger (2); zwei flexible Verschluss-Paneele (3) die am oberen Querträger (2) des Rahmens aufgehängt und durch Zwischenelemente in verschiedenen Höhen miteinander verbunden sind; außerdem Mittel zur Führung der Paneele entlang der vertikalen Pfosten des Rahmens und Betätigungsvorrichtungen zur Überführung der Verschluss-Paneele (3) von einer entfalteten geschlossenen Position in eine obere gefaltete offene Position, **dadurch gekennzeichnet, dass** die Betätigungsvorrichtungen der Verschluss-Paneele (3) Folgendes umfassen: widerstandsfähige und flexible Bänder oder Kabel (5) mit regulierbaren Kabelanschlüssen (51) zur vertikalen Betätigung der Zwischenelemente, welche die Verschluss-Paneele miteinander verbinden; sowohl auf einer horizontalen Achse als auch frei drehende, am

- oberen Querträger(2) montierte Scheiben (7), welche die unterschiedlichen vertikalen Seile oder Kabel in eine Zone führen, in welcher der Verlauf der Kabel (5) an ihrem festen Ende eine einfache oder mehrfache Schleife (5a) beschreibt, und einige Betätigungsmittel (9, 91), die auf die mittlere Zone der Schleifen (5a) einwirken, welche durch die Bänder(5) gegeben ist, was die Länge der besagten Schleifen (5a) verändert und das Tor öffnet oder schließt.
2. Tor nach Anspruch 1, **dadurch gekennzeichnet, dass** die an den Verschluss-Paneeelen(3) befestigten Zwischenelemente aus elastischen, stoßabsorbierenden Blöcke (4) mit vertikaler Öffnung (41) bestehen und für den Durchgang des entsprechenden Betätigungsseil oder-kabels (51) einen niedrigen Reibungskoeffizienten aufweisen.
3. Tor nach Anspruch 2, **dadurch gekennzeichnet, dass** die elastischen Blöcke (4) mindestens eine vertikale Ausrichtung festlegen.
4. Tor nach der Anspruch 2 oder 3, **dadurch gekennzeichnet, dass** die elastischen Blöcke (4) an ihren oberen und unteren Enden mit magnetischanziehenden Mitteln (6) ausgestattet sind, welche die genannten elastischen Blöcke (4) miteinander verbinden, sobald sie beim Öffnen der Tür einander berühren.
5. Tor nach einem der Ansprüche 2 bis 4, **dadurch gekennzeichnet, dass** die elastischen Blöcke (4) durch Befestigungsmittel mit den jeweiligen Verschluss-Paneeelen (3) der Tür verbunden sind.
6. Tor nach Anspruch 5, **dadurch gekennzeichnet, dass** die Befestigungsmittel der elastischen Blöcke (4) Platten (10) bilden, die an einigen inneren Vorsprüngen (11) der Verschluss-Paneele (3) und an den elastischen Blöcke (4) befestigt sind.
7. Tor nach Anspruch 6, **dadurch gekennzeichnet, dass** die Platten (10) mit Schrauben, Nieten, Schraubbolzen oder ähnlichen Mitteln an den inneren Vorsprüngen (11) der Verschluss-Paneele (3) und an den elastischen Blöcken (4) befestigt sind.
8. Tor nach einem beliebigen obengenannten Anspruch, **dadurch gekennzeichnet, dass** die Betätigungsvorrichtungen der Seilen oder Kabel (5) aus einem Mechanismus zur geradlinigen Bewegung (9) bestehen, der auf mindestens einen Scheibe (7a) einwirkt, welcher auf den Schleifen (5a) montiert ist, die von den Betätigungsseile oder -kabeln (5) gebildet werden.
9. Tor, nach Anspruch 8, dadurch gekennzeichnet dass die betätigungsmittel der Seile oder Kabel schließen
- ein Gegengewicht (91) zum geradlinigen Bewegungsmechanismus (9) verbunden und welche teilweise oder völlig Gegengewichtet das Gewicht des Tores, und der die Öffnung von demselben im Falle eines elektrischen Lieferungsfehlschlages befähigen kann.
10. Tor, nach Anspruch 9, dadurch gekennzeichnet dass die betätigungsmittel schließen einen Dämpfer und Verlangsamungsvorrichtung (92) des Gegengewichts ein, wenn es sich der unteren Position entsprechend der geschlossenen Position des Tores nähert.
11. Tor, nach einem der vorherigen Ansprüche, dadurch gekennzeichnet dass, die vertikalen Posten (1) des Rahmens einige antireibung paneelen (13), vertikal orientiert einschließen, die einige Mittel für das innere und äußerliche Führen der Verschluss-Paneeelen (3) des Tores definieren.
12. Tor, nach einem der vorherigen Ansprüche, dadurch gekennzeichnet dass, die betätigungsmittel der Seitenecken der Verschluss-Paneeelen (3) hinsichtlich der vertikalen Posten (1) schließen Paare von Rollen (14) die auf dem inneren Gesicht der vertikalen Posten (1) einwirken, und die zu den Verschluss-Paneeelen(3) befestigt werden.
13. Tor, nach Anspruch 12, dadurch gekennzeichnet dass, die Paare von Rollen (14) werden auf einer sich drehenden Achse (15) gemeinschaftlich mit einer befestigung schmale platte (16), auf solch eine Art versammelt, wie es durch und mit der Möglichkeit der vertikalen Bewegung, in einer vertikalen Rinne (19) des entsprechenden vertikalen Postens (1) des Rahmens und befestigt zu den Verschluss-Paneeelen (3) der Tor geht.
14. Tor, nach Anspruch 13, dadurch gekennzeichnet dass der Befestigen-Drucktiegel die schmale platten (16) zum befestigen der Paare von Rollen (14) sind verbunden zu den Verschluss-Paneeelen (3) mittels Träger (17) befestigt zu den schmale Platten (10).
15. Tor, nach Anspruch 14, dadurch gekennzeichnet dass die schmalen Platten (16) zum befestigen die Paare von Rollen (14) sind zu den Verschluss-Paneeelen(3) mittels eines Spanner-Elements befestigt, das die schmale Platten (16) und die Rollen (14) in entgegengesetzten Richtungen treibt.
16. Tor, nach einem der Ansprüche 13, 14 oder 15, dadurch gekennzeichnet dass, die befestigungs Platte (16) definiert eine mechanische Sicherung mit einer geeigneten Abschnitt, um eine spezifische Spannung zu tragen.

17. Tor, nach einem der vorherigen Ansprüche, dadurch gekennzeichnet dass, die scheiben (7) Seiten-Hälte (8), aufweisen um die Kabel davon abzuhalten, die Führer zu verlassen, und den Durchgang der horizontalen Kabel (5) zur entsprechenden vertikalen Reihe zu erlauben.
18. Tor, nach einem der vorherigen Ansprüche, dadurch gekennzeichnet dass, das obere Querstück (2) hat Längskanäle (23) darin denen rohrförmigen Befestigungselemente (31) eingesteckt sind, die an die Verschluss paneele (31) fixiert sind; und flexiblen Profilen (32) eines selbstschmierendes un gleitfähiges material, für das Zurückhalten der Befestigungs Elemente (31) auf dem Inneren der Längskanäle des oberen Querstücks.

Revendications

1. Porte d'ouverture rapide, de double panneau, du type qui comprends: Une armature avec deux montants verticaux (1) et un une traverse supérieure (2), deux panneaux flexibles de fermeture (3), suspendus de la traverse supérieure (2) de l'armature et reliés entre eux à différentes hauteurs par des éléments intermédiaires, des moyens de guidage des panneaux dans les montants verticaux de l'armature et des dispositifs d'actionnement pour les panneaux de fermeture (3) depuis une position déployée de fermeture à une position supérieure pliée d'ouverture; **caractérisée en ce que** les dispositifs d'actionnement des panneaux de fermeture (3) comprennent : des cordes ou des câbles (5) résistants et flexibles ayant des arrêts ajustables (51) pour l'actionnement vertical des éléments intermédiaires qui relient les panneaux de fermeture entre eux, un axe horizontal et des poulies a rotation libre (7) montées à la traverse supérieure (2) pour le guidage de différentes cordes ou de câbles verticaux vers une zone dans laquelle les dits câbles (5) définissent une boucle simple ou multiple (5a) avec l'extrémité fixe du câble et les moyens d'actionnement (9, 91), qui agissent sur la zone moyenne des boucles (5a) définis par les câbles (5), en produisant une variation de la longueur des dites boucles (5a) et l'ouverture ou la fermeture de la porte.
2. Porte, selon la revendication 1, **caractérisée en ce que** les éléments intermédiaires fixés aux panneaux de fermeture (3) sont constitués au moyen de blocs élastiques d'absorption d'impacts (4) qui ont une ouverture verticale (41) avec un bas coefficient de friction pour le pas de la correspondante corde ou câble (5).
3. Porte, selon la revendication 2, **caractérisée en ce que** les blocs élastiques (4) définissent, au moins, une rangée verticale.
4. Porte, selon l'une quelconque des revendications 2 ou 3, **caractérisée en ce que** les blocs élastiques (4) ont des moyens d'attraction magnétique (6) dans les extrémités supérieures et inférieures, destinés à les maintenir unis quand les dits blocs élastiques (4) établissent contact l'un l'autre durant l'ouverture de la porte.
5. Porte, selon l'une quelconque des revendications 2 à 4, **caractérisée en ce que** les blocs élastiques (4) sont reliés aux panneaux respectifs de fermeture (3) de la porte au moyen de dispositifs de fixation.
6. Porte, selon la revendication 5, **caractérisée en ce que** les dispositifs de fixation des blocs élastiques (4) forment des platines (10) fixées a des saillants internes (11) des panneaux de fermeture (3) et des blocs élastiques (4).
7. Porte, selon la revendication 6, **caractérisée en ce que** les platines (10) sont fixées aux saillants internes (11) des panneaux de fermeture (3) et des blocs élastiques (4) au moyen des vis, des rivets, des boulons ou d'autres moyens similaires.
8. Porte, selon l'une quelconque des revendications antérieures, **caractérisée en ce que** les dispositifs d'actionnement des cordes ou de câbles (5) sont constitués par des mécanismes de mouvement linéaire (9) qui agissent au moins sur une poulie (7a) montée aux boucles (5a) définis par les cordes ou les câbles d'actionnement (5).
9. Porte, selon la revendication 8, **caractérisée en ce que** les dispositifs d'actionnement des cordes ou câbles incluent un contrepoids (91) relié au mécanisme de mouvement linéaire (9) et qui compense un total ou partiellement le poids de la porte et qui peut faciliter l'ouverture de la même dans le cas de faute de fourniture électrique.
10. Porte, selon la revendication 9, **caractérisée en ce que** les dispositifs d'actionnement comprennent un amortisseur et un dispositif de décélération (92) du contrepoids quand il se rapproche de la position basse, en correspondant à la position fermée de la porte.
11. Porte, selon l'une quelconque des revendications antérieures, **caractérisée en ce que** les montants verticaux (1) de l'armature incluent des panneaux un anti-friction (13) disposés verticalement, qui définissent des moyens pour le guidage interne et externe des panneaux de fermeture (3) de la porte.
12. Porte, selon l'une quelconque des revendications antérieures, **caractérisée en ce que** les dispositifs

de déplacement des bords latéraux des panneaux de fermeture (3) en ce qui concerne les montants verticaux (1) comprennent des paires de rouleaux (14) qui agissent sur la face interne des montants verticaux (1) et qui sont fixés aux panneaux de fermeture (3). 5

13. Porte, selon la revendication 12, **caractérisée en ce que** les paires de rouleaux (14) sont montées sur un axe de rotation (15) conjointement avec une platine de fixation montée (16), de telle sorte qu'il la traverse avec possibilité de déplacement vertical, dans une rainure verticale (19) du montant correspondant (1) de l'armature et fixée aux panneaux de fermeture (3) de la porte. 10 15
14. Porte, selon la revendication 13, **caractérisée en ce que** les platines de fixation (16) des paires de rouleaux (14) sont fixées aux panneaux de fermeture (3) au moyen des supports (17) fixés aux platines (10). 20
15. Porte, selon la revendication 14, **caractérisée en ce que** les platines de fixation (16) des paires de rouleaux (14) sont fixées aux panneaux de fermeture (3) au moyen d'un élément tenseur qui pousse les platines de fixation (16) et les rouleaux (14) dans des directions opposées. 25
16. Porte, selon l'une quelconque des revendications 13, 14 ou 15, **caractérisée en ce que** la platine de fixation (16) définit un fusible mécanique avec section appropriée pour supporter un effort déterminé. 30
17. Porte, selon l'une quelconque des revendications antérieures, caractérisée parce que les poulies (7) ont des arrêts latéraux (8) pour empêcher que les câbles sortent des guides et permettre le pas des câbles horizontaux (5) vers la rangée verticale correspondante. 35 40
18. Porte, selon l'une quelconque des revendications antérieures, **caractérisée en ce que** la traverse supérieure (2) présente des canaux longitudinaux (23) dans lesquels sont logés des éléments tubulaires de fixation (31), fixés aux panneaux de fermeture (3), et des profils flexibles (32) d'un matériel auto-lubrifiant et de glissement, pour la rétention des éléments tubulaires (31) à l'intérieur des canaux longitudinaux de la traverse supérieure. 45 50

55

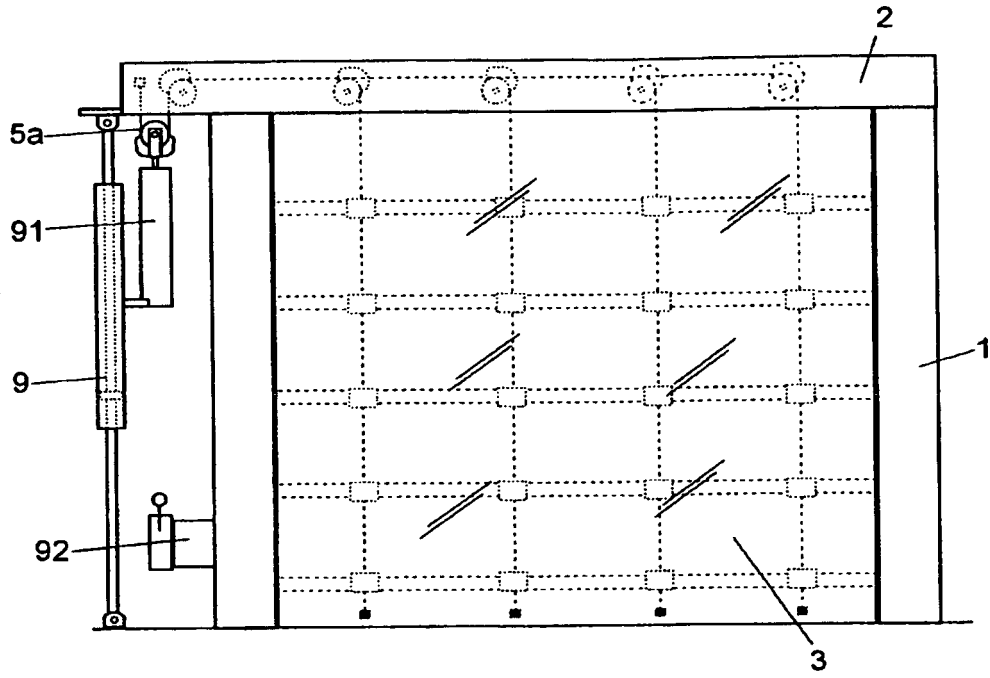

Fig. 1

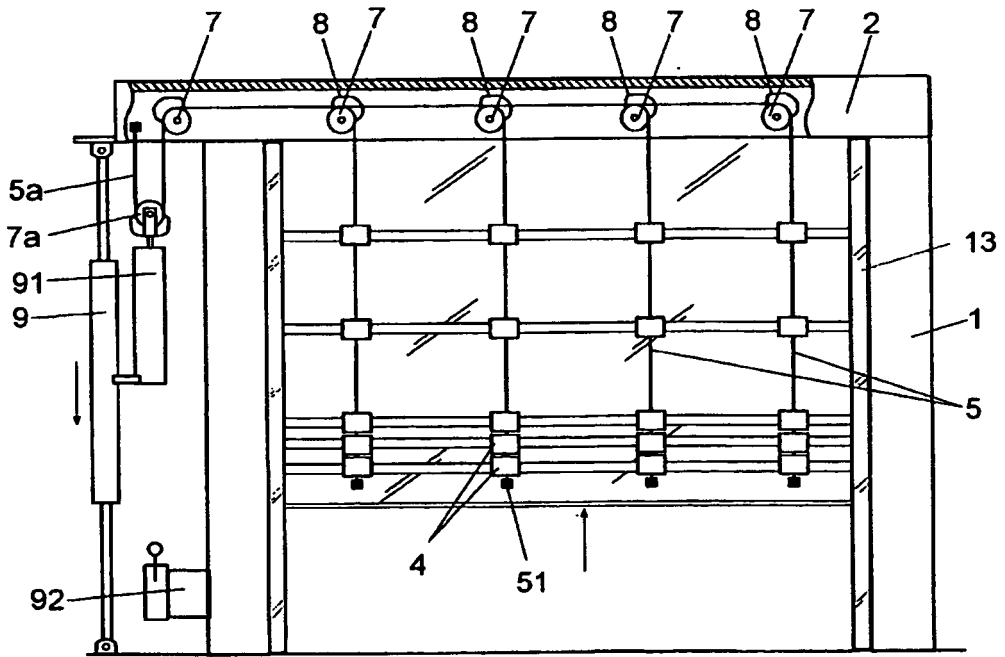

Fig. 2

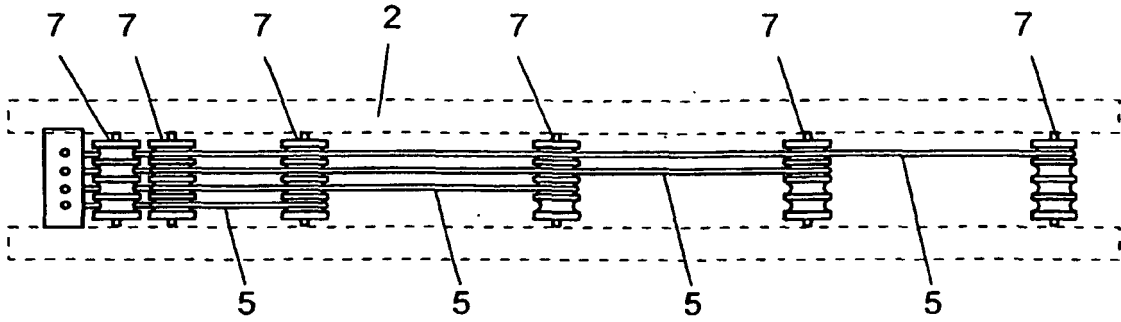

Fig. 3

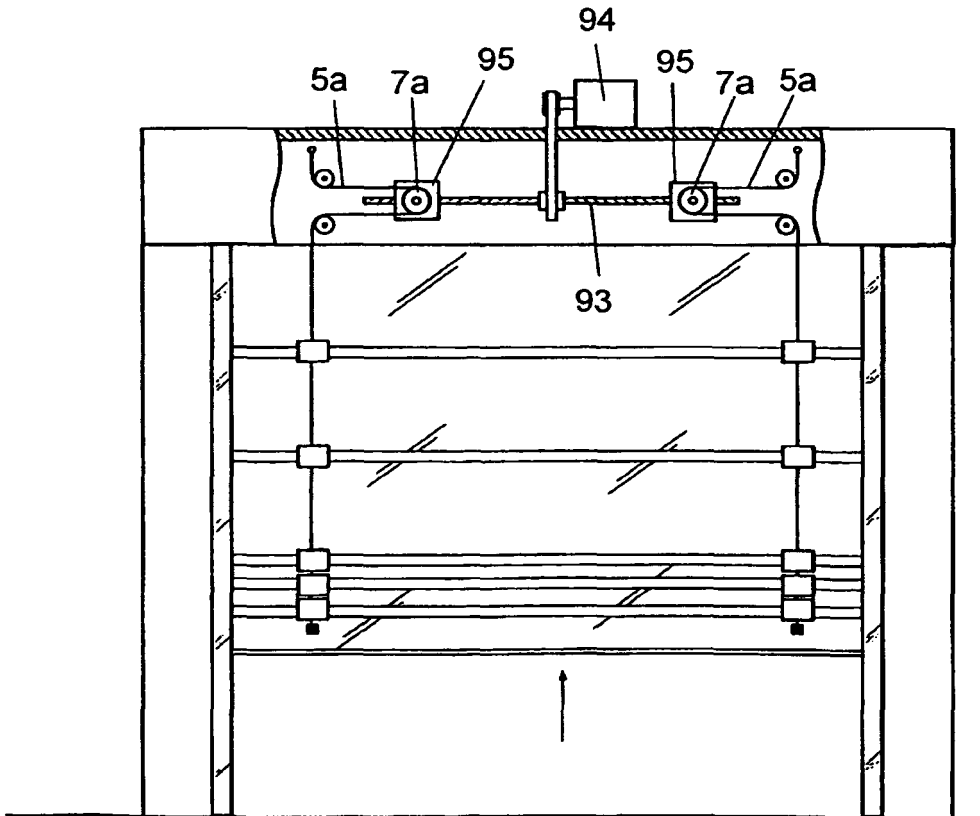

Fig. 4

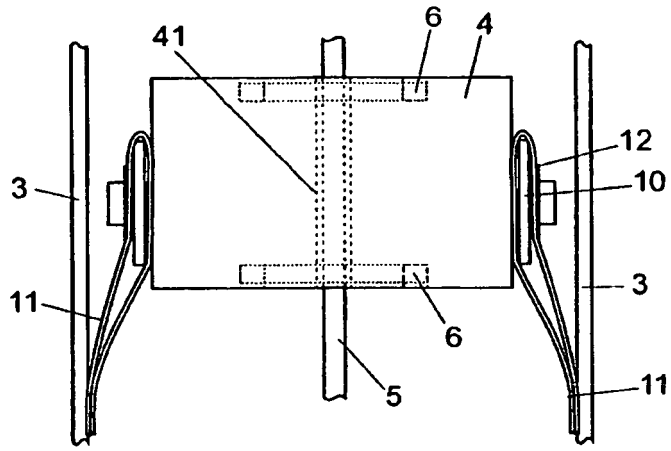

Fig. 5

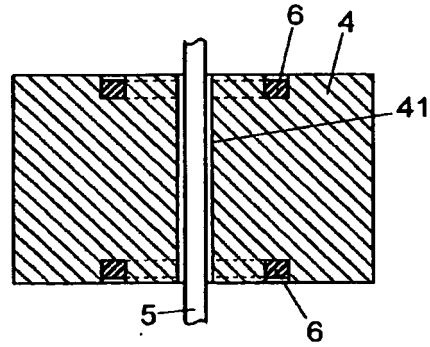

Fig. 6

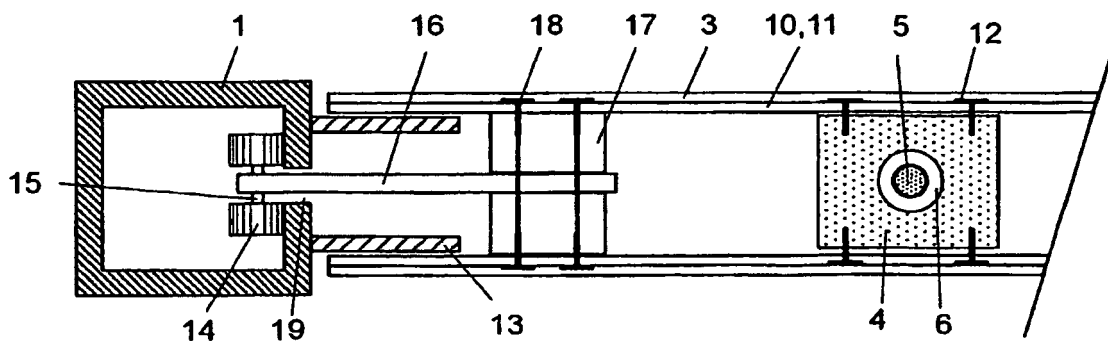

Fig. 7

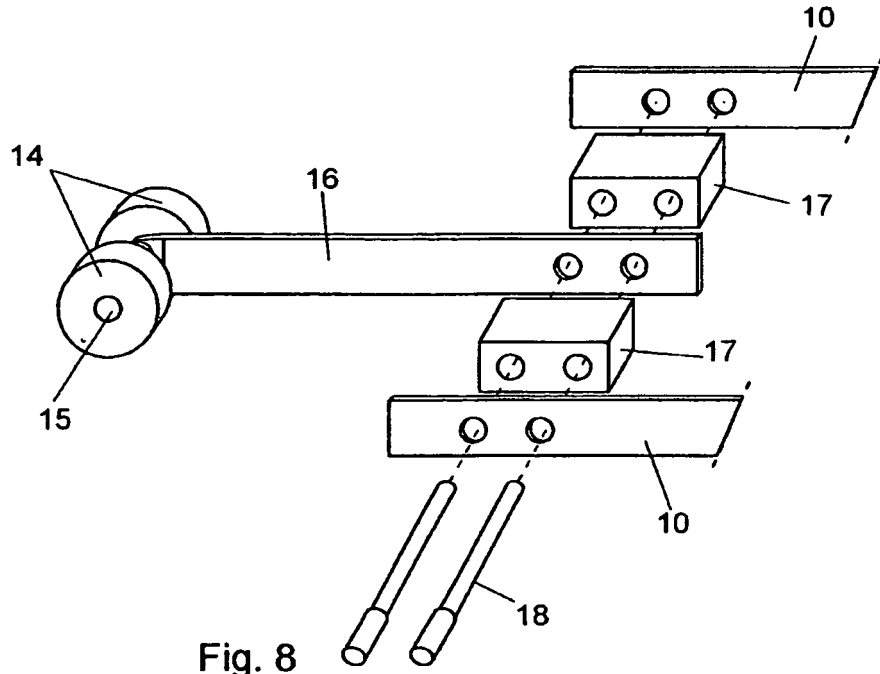

Fig. 8

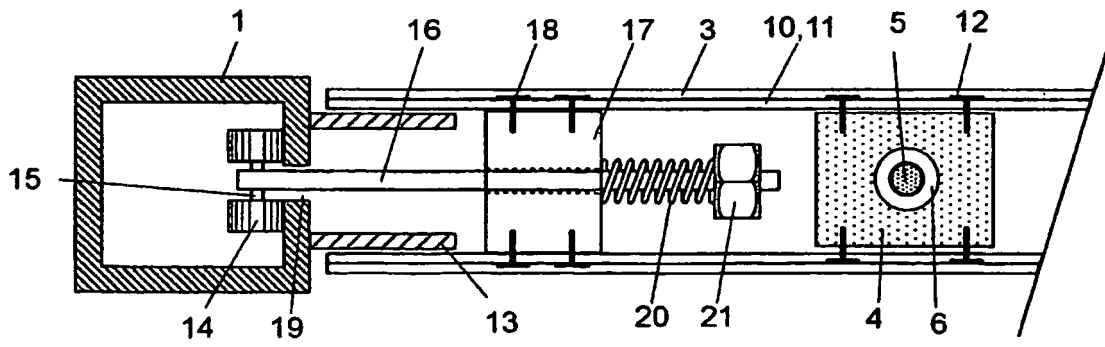

Fig. 9

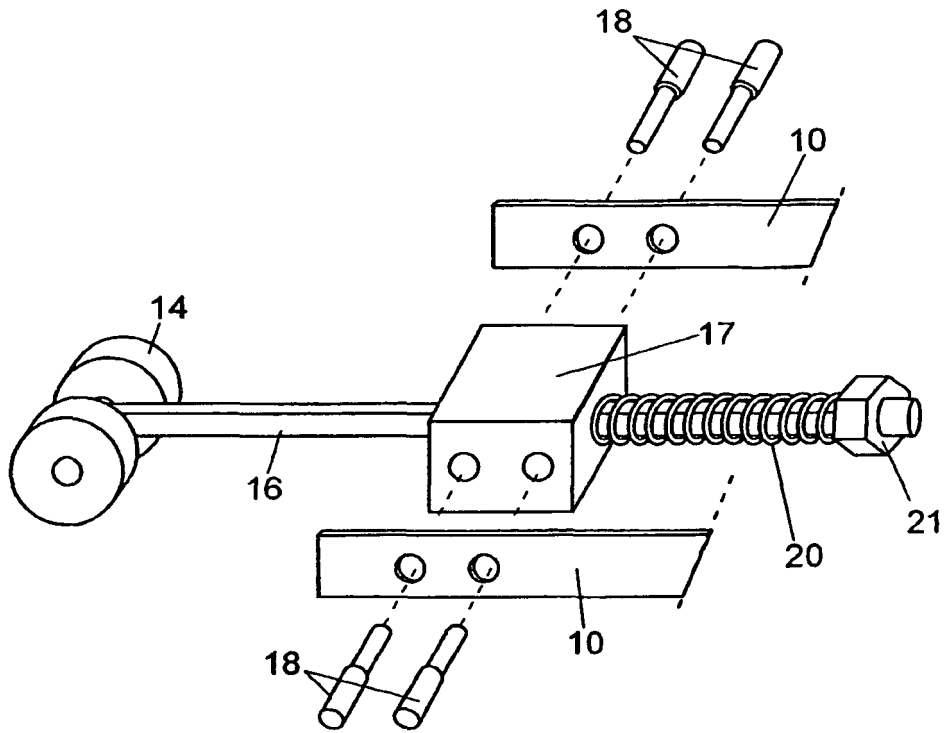

Fig. 10

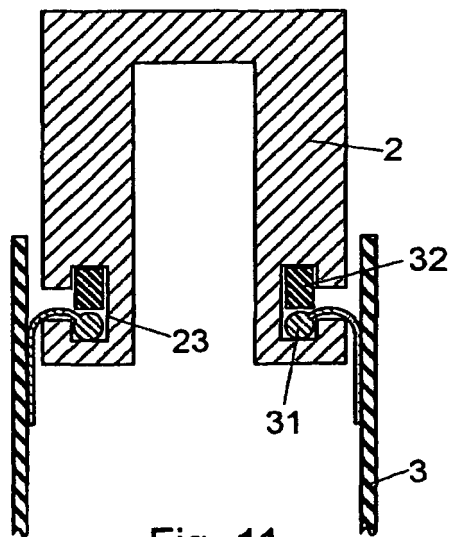

Fig. 11

REFERENCES CITED IN THE DESCRIPTION

This list of references cited by the applicant is for the reader's convenience only. It does not form part of the European patent document. Even though great care has been taken in compiling the references, errors or omissions cannot be excluded and the EPO disclaims all liability in this regard.

Patent documents cited in the description

- WO 2007107609 A [0002]