



(11) **EP 2 289 594 B9**

(12) **CORRECTED EUROPEAN PATENT SPECIFICATION**

(15) Correction information:
Corrected version no 1 (W1 B1)
Corrections, see
Description Paragraph(s) 23
Claims EN 9

(51) Int Cl.:
A61N 1/05 ^(2006.01) **A61N 1/36** ^(2006.01)
A61F 9/08 ^(2006.01)

(48) Corrigendum issued on:
08.10.2014 Bulletin 2014/41

(45) Date of publication and mention
of the grant of the patent:
02.07.2014 Bulletin 2014/27

(21) Application number: **10015489.7**

(22) Date of filing: **01.05.2001**

(54) **Artificial retina device**

Künstliche Netzhautvorrichtung

Dispositif de rétine artificielle

(84) Designated Contracting States:
AT BE CH CY DE DK ES FI FR GB GR IE IT LI LU
MC NL PT SE TR

(30) Priority: **04.05.2000 US 564841**

(43) Date of publication of application:
02.03.2011 Bulletin 2011/09

(62) Document number(s) of the earlier application(s) in
accordance with Art. 76 EPC:
09013945.2 / 2 158 937
01928985.9 / 1 278 572

(73) Proprietor: **Pixium Vision SA**
75012 Paris (FR)

(72) Inventors:
• **Chow, Alan Y.**
60187 Wheaton, IL (US)
• **Chow, Vincent Y.**
60103 Hanover Park, IL (US)

(74) Representative: **Graf von Stosch, Andreas et al**
Graf von Stosch
Patentanwalts-gesellschaft mbH
Prinzregentenstrasse 22
80538 München (DE)

(56) References cited:
US-A- 4 628 933 US-A- 5 109 844
US-A- 5 895 415

EP 2 289 594 B9

Note: Within nine months of the publication of the mention of the grant of the European patent in the European Patent Bulletin, any person may give notice to the European Patent Office of opposition to that patent, in accordance with the Implementing Regulations. Notice of opposition shall not be deemed to have been filed until the opposition fee has been paid. (Art. 99(1) European Patent Convention).

Description

FIELD OF THE INVENTION

[0001] The present invention is generally directed to medical devices. More particularly, the present invention is directed to an artificial retina medical device and method to more efficiently stimulate electrically and with higher resolution, neuroretinal cells in partially damaged retinas to produce artificial vision. The invention provides improved efficiency and resolution of the device by using transretinal electrical current stimulation provided by stimulation and ground return electrodes that are disposed on opposite sides of the neuroretina.

BACKGROUND

[0002] A variety of retina diseases cause vision loss or blindness by destruction of the vascular layers of the eye that include the choroid and choriocapillaris, and the outer retinal layers that include Bruch's membrane and retinal pigment epithelium. Loss of these layers is often accompanied by degeneration of the outer portion of the neuroretina, typically the photoreceptor layer. Variable sparing may occur of the remaining neuroretina composed of the outer nuclear, outer plexiform, inner nuclear, inner plexiform, ganglion cell and nerve fiber layers.

[0003] Known prior efforts to produce vision by retinal electrical stimulation used arrays of stimulating electrodes with their ground return electrode or electrodes disposed either entirely on the epiretinal or the subretinal side of the neuroretina. Placement of stimulating and ground return electrodes together in this fashion resulted in inefficient stimulation of the neuroretina because the electrical field was not forced directly through the neuroretina. Resolution was also degraded because of diffuse spreading of each stimulating electrode's electrical field.

[0004] The patent document US 4, 628, 933 discloses the preamble of claim 1.

BRIEF SUMMARY OF THE PREFERRED EMBODIMENTS

[0005] The artificial retina device of this invention is preferably composed of two basic units, the stimulating electrode unit and the ground return electrode unit. In one embodiment, the two units are physically and electrically continuous, or physically and electrically connected by an insulated tail-like conductor that in some embodiments supports, positions, and aligns the two units on opposite sides of the neuroretina relative to each other. The stimulating electrode unit is, for example, a silicon disk 3 mm in diameter and 25 microns thick, and is comprised of separated stimulating microelectrode subunits. Preferably, the stimulating electrode unit has a ground return electrode unit extending from one edge, comprised of a silicon tail with an insulated conductor leading to the

ground return electrode at its tip. The stimulating microelectrode subunits of the stimulating electrode units deliver current generated by one or more microphotodiodes connected, for example, in series and fabricated within the subunit. The preferred number of microphotodiodes per subunit is one.

[0006] In other embodiments, each microelectrode subunit is preferably fabricated on a node of a disk-shaped silicon web, the subunits separated by open areas of the web. The open areas of the web allow nourishment and oxygen from the outer retinal circulation to diffuse into the neuroretina.

[0007] In the preferred embodiment, on the backside of the stimulating electrode unit, i.e. the side opposite the incident light side, an insulated common conductor is constructed and arranged to electrically ground the microelectrode subunits. The common ground conductor preferably continues along the length of the ground return electrode unit and terminates in an exposed ground return electrode at or near the tip of the ground return electrode unit, and disposed in the vitreous cavity. The exposed ground return electrode tip in the vitreous cavity allows the electrical field generated by the microelectrode subunits in the subretinal space to transretinally stimulate the neuroretina.

[0008] In a second embodiment, an additional tail with an embedded conductor and an electrode tip is connected to the ground electrode tip of the ground electrode unit to extend the location of the ground electrode further into the vitreous cavity.

[0009] In an exemplary arrangement, the conductor of the ground electrode unit is electrically connected with an additional bias photodiode or photodiodes to increase the voltage and current generated by the device. In this latter case, the ground electrode of the device is preferably disposed on the additional bias photodiode or photodiodes disposed in the vitreous cavity.

[0010] In another exemplary arrangement, the bias photodiode or photodiodes are placed in the lens capsular bag of the eye after surgical removal of the lens nucleus and cortical material.

BRIEF DESCRIPTION OF THE DRAWINGS

[0011] Other features and advantages of the invention will be apparent to those skilled in the art with reference to the detailed description and the drawings, of which:

FIG. 1A is a plan view of a preferred embodiment showing the stimulating electrode unit and the ground return electrode unit.

FIG. 1B is a side view of FIG. 1A showing the stimulating electrode unit and the ground return electrode unit.

FIG. 2A is a plan view of the tail extension of the preferred embodiments, that physically and electrically couples to the ground return electrode unit of FIGS. 1A and 1B to extend the location of the ground

return electrode further into the vitreous cavity of the eye.

FIG. 2B is a cross-sectional view of the tail extension of the preferred embodiments.

FIG. 3 is a perspective view showing the tail extension of FIGS. 2A and 2B attached to the ground return electrode unit of FIGS. 1A and 1B.

FIG. 4 is a perspective view of another exemplary arrangement showing the stimulating electrode unit fabricated as a circular silicon web to allow nourishment to flow between the choroid and the neuroretina, and the stimulating electrode subunits fabricated at the intersecting nodes of the web.

FIGS. 4A and 4B are magnified plan and sectional views respectively of the exemplary arrangement of FIG. 4 where the stimulating electrode subunits of the stimulating electrode unit are each comprised of three microphotodiodes electrically connected in series to increase the voltage output of each stimulating electrode subunit.

FIG. 5 is a cross-sectional view of FIGS. 1A and 1B, in the eye with a stimulating electrode unit in the subretinal space and a ground return electrode of the ground return electrode unit exposed in the vitreous cavity.

FIG. 6 is a cross-sectional view of the device of FIG. 5 with the attached tail extension of FIGS. 2A and 2B.

FIG. 7 is a cross-sectional view of another exemplary arrangement, showing the device of FIGS. 1A and 1B with an electrode stimulating unit implanted in the subretinal space and a ground return electrode loop of the ground return electrode unit disposed in the vitreous cavity.

FIG. 8 is a cross-sectional view of another exemplary arrangement, showing the device of FIGS. 1A and 1B with a stimulating electrode unit implanted in the subretinal space and a tail extension electrically connecting to a bias photodiode disposed in the lens capsule of the eye, the bias photodiode containing the extended location of the ground return electrode, and the bias photodiode providing additional voltage and/or current to the electrode stimulating unit in the subretinal space.

FIG. 9 is a cross-sectional view of another exemplary arrangement, showing the device of FIGS. 1A and 1B with its stimulating electrode unit implanted in the subretinal space and a tail extension electrically connecting to a bias photodiode disposed in front of the iris, in the anterior chamber of the eye, the bias photodiode containing the extended location of the ground return electrode, and the bias photodiode providing additional voltage and/or current to the electrode stimulating unit in the subretinal space.

DETAILED DESCRIPTION OF THE PREFERRED EMBODIMENTS

[0012] Referring to the drawings, as shown in FIGS.

1A and 1B, the preferred embodiment of retinal device 10 has a stimulating electrode unit 12 and a curved ground return electrode unit 16 configured for implantation into an eye such that the retinal device may be positioned completely inside the eye and stimulate opposite or substantially opposite sides of the neuroretina. The two components 12 and 16 are preferably physically fabricated on a single thin silicon chip substrate 11, but may be fabricated separately and then joined together. The stimulating electrode unit 12 includes an array of stimulating electrode subunits 22 each composed of one or more electrical sources such as a photodetector or photodetectors. In a preferred embodiment, the photodetectors may be implemented as microphotodiodes 23a electrically connected, for example, in series.

[0013] A stimulating electrode 23b contacts at least one of individual cells, groups of cells, portions of cells and nerve fibers of the neuroretina. The ground return electrode 14 is preferably disposed at or near the tip of the ground return electrode unit 16. The stimulating electrode 23b and ground return electrode 14 are disposed on opposite sides of a neuroretina, or if the neuroretina is partially missing or damaged, then on opposite sides of the remainder of the neuroretina. In a preferred embodiment, the stimulating electrode 23b is disposed in a subretinal space of the neuroretina and the ground return electrode 14 is disposed on an epiretinal side of the neuroretina. In another embodiment, the positions are reversed, with the ground return electrode 14 being disposed in the subretinal space of the neuroretina and the stimulating electrode 23b being disposed on the epiretinal side of the neuroretina.

[0014] Also as shown in FIGS. 1A and 1B, exemplary components of the preferred embodiment of retinal device 10 includes the thin silicon substrate 11, stimulating electrode unit 12, stimulating electrode subunits 22, microphotodiodes 23a electrically connected, for example, in series, within stimulating electrode subunits 22 and an iridium/iridium oxide stimulating electrode 23b of stimulating electrode subunits 22. The microphotodiodes 23a or other electrical source preferably provides stimulation to the neuroretina from the subretinal and vitreous cavity sides of the eye. Alternatively, The electrical source could provide stimulation from outside the eye in response to incident light. For example, the electrical source could send signals proportional to sensed incident light via hardwiring into the subretinal space and vitreous cavity of the eye. In another embodiment, the electrical source could transmit a signal in a wireless fashion to the eye using, for example, radio frequency (RF) to send signals to a coil located in the eye that is in communication with the stimulation and ground electrodes. Other known mechanisms may also be used for providing electrical energy to the eye in response to incident light.

[0015] Also included with the ground return electrode unit 16 is a silicon nitride stress layer 17 that preferably shapes the ground return electrode unit 16 in a generally curved shape to direct the ground return electrode unit

16 into the vitreous cavity. Although a curve directs the ground electrode unit 16 into the vitreous cavity, other shapes could be used, such as an angled ground electrode, to perform the same function, but may be more difficult to fabricate. The ground return electrode 14 is preferably produced of an iridium/iridium oxide and includes a titanium adhesion layer 14a and a P+ tub 14b disposed under a titanium adhesion layer 14a to allow electrical contact with the doped silicon substrate 11. The retinal device 10 also preferably includes a silicon dioxide layer 15 that insulates the stimulating electrode unit 12 and ground return electrode unit 16.

[0016] As shown in FIGS. 1A and 1B, the stimulating electrode unit 12 includes a plurality of stimulation electrode subunits 22 having one or more microphotodiodes 23a electrically connected, for example, in series within each electrode subunit 22. The preferred number of microphotodiodes 23a is one unit per microelectrode subunit 22. The layers of the microphotodiode are, for example, from the incident light surface, the iridium/iridium oxide electrode 23b, titanium adhesion layer 23c, N+ tub 23d, intrinsic layer 23e and the silicon substrate 11. Those skilled in the art will appreciate that other arrangements could be used where the microelectrode subunits are subunits capable of generating electrical current.

[0017] Also shown in FIGS. 1A and 1B, the ground return electrode unit 16 preferably includes a positioning hole 24 that allows the retinal device 10 to be positioned with instruments during surgery. The ground return electrode unit 16 in another arrangement includes notches 26 that allow a secure fit for attachments that have corresponding protrusions that fit into the notches 26, as described in more detail below.

[0018] As shown in FIGS. 2A and 2B, a tail extension 30 is disclosed for attachment to the ground return electrode unit 16 (shown in FIGS. 1A and 1B) to extend the electrical termination of the ground return electrode 14 (shown in FIGS. 1A and 1B), for example, further into the vitreous cavity. Further extension of the ground electrode into the vitreous cavity may be required to diminish undesirable skewing of the electric field that travels from the stimulating towards the ground electrode. Such a skewed electric field is less efficient in stimulating the neuroretina compared to an electrical field that is arranged in a direction perpendicular to the neuroretinal surface.

[0019] FIG. 2A is a plan view and FIG. 2B is a side view of the tail extension 30. The tail extension attachment 30 is constructed of a biocompatible material 31, such as Parylene or a similar biocompatible material and is preferably manufactured with a curve. The tail extension attachment 30 also includes an embedded conductor 34, insulated by the surrounding material 31, terminating in a tail extension ground return electrode 32 at or near an end of the tail extension attachment 30, preferably to locate the electrode as far into the vitreous cavity as possible. The conductor 34 of the tail extension attachment 30 is designed to electrically contact the ground

return electrode 14 when the tail extension attachment 30 is attached to the ground return electrode unit 16 (shown in FIGS. 1A and 1B). The tail extension ground electrode 32 is preferably constructed of iridium/iridium oxide, or other suitable electrode material.

[0020] Also referring to FIGS. 1A and 1B, the tail extension attachment 30 has a pocket 36 that fits over the ground electrode unit 16 to establish electrical contact with the ground return electrode 14. Inside the pocket 36 are protrusions 38, which fit into the notches 26 of the ground return electrode unit 16. The protrusions 38 are preferably constructed of a biocompatible material, such as Parylene, or a similar biocompatible material. The tail extension attachment 30 includes a slot 40 that allows the positioning hole 24 of the ground return electrode unit 16 to be accessed by an instrument (not shown).

[0021] FIG. 3 is a perspective view showing the tail extension 30 (shown in FIGS. 2A and 2B) electrically attached with the ground return electrode unit 16 of the retinal device 10. The conductor 34 of the tail extension 30 contacts the ground return electrode 14 of the ground return electrode unit 16. The tail extension 30 is preferably curved to position its ground return electrode 32 into the vitreous cavity of the eye. Those skilled in the art will appreciate that other shapes of the tail extension could be used as long as the shape positions the ground return electrode into the vitreous of the eye. The stimulating electrode unit 12 is also shown.

[0022] FIG. 4 is a perspective view of another exemplary arrangement of the retinal device 10 shown in FIGS. 1A and 1B. Like components are labeled using the same reference numerals followed by a letter. Alternative embodiment retinal device 10a is similar to the preferred embodiment retinal device 10 shown in FIGS. 1A and 1B, except that the stimulating electrode unit 12a is fabricated as a disk-shaped web 17 to allow nourishment to flow between the choroid and the neuroretina, and the stimulating electrode subunits 22a are fabricated at the intersecting nodes of the web 17. Preferably, the web is manufactured of silicon and can be perforated. The alternative exemplary arrangement retinal device 10a is thus similar to the preferred embodiment retinal device 10 with the addition of fabricated nutrient openings 13.

[0023] FIG. 4A is a magnified plan view, and FIG. 4B is sectional view taken through section III - III of FIG. 4A of an alternative exemplary arrangement of the retinal device 10a shown in FIG. 4. The stimulating electrode subunits 22a of the stimulating electrode unit 12a shown in FIG. 4 are each comprised of first, second, and third microphotodiodes 24, 25, 26 electrically connected, for example, in series within stimulating electrode subunit 22a to increase the output voltage of each stimulating electrode subunit 22a. The stimulating electrode subunits 22a contact a common ground conductor 28d via a contact pad 28c.

[0024] Preferably the common ground conductor 28d and contact pad 28c are insulated during fabrication, for example, by silicon dioxide 29 deposition. For clarity pur-

poses, preferably only the layers of one of the microphotodiodes connected electrically in series is labeled; they are the N⁺ layer 24a, the N type silicon substrate 24b, the intrinsic layer 24c, and the P⁺ layer 24d. Conductors 27b, 28b are preferably deposited over insulating layers of silicon dioxide 27a, 28a to electrically connect the adjacent microphotodiodes 24, 25, 26. An insulating layer of silicon dioxide 27c covers conductor 27b. The stimulating electrode 27 of each stimulating electrode subunit 22a is preferably fabricated from iridium/iridium oxide deposited over a titanium adhesion layer. Those skilled in the art will appreciate that other electrode materials, for example, noble metals like platinum and tantalum, may be used. The common ground conductor 28d of the stimulating electrode subunits 22a terminates electrically, for example, at or near the ground return electrode 14a of the ground return electrode unit 16a, shown in FIG. 4.

[0025] FIG. 5 is a cross-sectional view showing the preferred embodiment retinal device 10 of FIGS. 1A and 1B implanted in the eye 6 with the stimulating electrode unit 12 disposed in the subretinal space between the neuroretina 50 and the retinal pigment epithelium 52, and the ground return electrode unit 16 in the vitreous cavity 54. Light images 56 enter the eye 6 through the cornea 58 and lens 60 and are focused onto the stimulating electrode unit 12. Patterned electrical stimuli are then generated by the microphotodiodes of the electrode subunits 22 (FIG. 1A) that stimulate the overlying neuroretina 50 in the pattern of the image. For purposes of reference, other structures of the eye 6 that are shown are an iris 62, a sclera 64 and an optic nerve 66.

[0026] FIG. 6 shows a cross-sectional view of an alternate embodiment retinal device 10b, including the preferred embodiment retinal device 10 as described in FIGS. 1A and 1B and other features. The alternate embodiment retinal device 10b includes the stimulating electrode unit 12 disposed in the subretinal space between the neuroretina 50 and the retinal pigment epithelium 52, and the ground return electrode unit 16 in the vitreous cavity 54, with attached tail extension 30 of FIGS. 2A and 2B. A purpose of the tail extension 30 is to electrically extend the location of the ground return electrode further into the vitreous cavity 54 to prevent skewing of the transretinal electric field between the stimulating electrode unit 12 and the ground return electrode unit 16 as the electric field traverses through the neuroretina 50. A non-skewed electrical field that is perpendicular to the neuroretina vitreous-facing surface efficiently stimulates remaining neuroretinal cells. For reference purposes, other items and structures of the eye that are shown are the cornea 58, iris 62, lens 60, sclera 64, optic nerve 66 and the incident light images 56.

[0027] FIG. 7 shows a cross-sectional view of another exemplary arrangement of the retinal device 10c including the preferred embodiment retinal device 10 as described in FIGS. 1A and 1B and other features. The stimulating electrode unit 12 is disposed in the subretinal

space between the neuroretina 50 and the retinal pigment epithelium 52, and the ground return electrode unit 16 is disposed in the vitreous cavity 54, including a tail extension 30a that has a generally looped ground electrode. Although the stimulating electrode unit 12 is preferably positioned in the subretinal space with the ground return electrode unit 16 positioned in the vitreous cavity, in other exemplary arrangements the positioning of the stimulating electrode unit 12 and ground electrode unit 16 may be reversed.

[0028] A purpose of the loop electrode of the tail extension 30a is to electrically extend the location of the ground return electrode further into the vitreous cavity 54 and in an even manner. An evenly disposed ground electrode in the vitreous cavity relative to the subretinal stimulating electrode array aids the maintenance of a transretinal stimulating electrical field in a perpendicular direction relative to the neuroretinal surface. Such an alignment of the electrical field relative to the neuroretinal surface efficiently stimulates the neuroretina, as compared to, for example, a transretinal electrical field that is skewed to the neuroretinal surface. For purposes of reference, other items and structures of the eye that are shown are the cornea 58, iris 62, lens 60, sclera 64, optic nerve 66 and the incident light images 56.

[0029] FIG. 8 shows a cross-sectional view of yet another exemplary arrangement retinal device 10d including the preferred embodiment retinal device 10 as described in FIGS. 1A and 1B, including an attached tail extension 30b. The tail extension electrically connects with at least one bias photodiode 30c disposed in the lens capsule 60b of the eye 6, the bias photodiode 30c containing the extended location of the ground return electrode 32b. The bias photodiode 30c provides additional voltage and/or current to the electrode stimulating unit 12 in the subretinal space. Additional stimulating voltage and the resulting current may be required to stimulate more severely damaged retinas compared to less severely damaged retinas. The bias photodiode, which may also be a series of photodiodes 30c are electrically connected together in a series or parallel configuration, as is known in the art, to provide the increased voltage and/or current. For purposes of reference, other items and structures of the eye 6 that are shown are the cornea 58, iris 62, sclera 64, neuroretina 50, retinal pigment epithelium 52, optic nerve 66, and the incident light images 56.

[0030] FIG. 9 shows a cross-sectional view of yet another exemplary arrangement retinal device 10e including the preferred embodiment retinal device 10 as described in FIGS. 1A and 1B, and an attached tail extension 30d that electrically connects with at least one bias photodiode 30e preferably disposed in front of the iris 62 of the eye 6. The placement of at least one bias photodiode in this location allows all of the bias photodiode to be exposed to light, compared to a bias photodiode disposed behind the iris. The bias photodiode 30e contains the extended location of the ground return electrode 32c,

and the bias photodiode or photodiodes 30e to provide additional voltage and/or current to the electrode stimulating unit 12 in the subretinal space. The bias photodiode or photodiodes 30e are electrically connected together in a series or parallel configuration to provide increased voltage and/or current, as is known in the art. For reference purposes, other items and structures of the eye 6 that are shown are the cornea 58, lens 60, sclera 64, neuroretina 50, retinal pigment epithelium 52 and optic nerve 66, and the incident light images 56.

Claims

1. An artificial retina device (10) for electrically stimulating a neuroretina of an eye to produce artificial vision, the artificial retina device (10) comprising:

at least one stimulating electrode (23b, 27) for connection with an electrical source, wherein the at least one stimulating electrode (23b, 27) is configured to be disposed or implanted for electrical contact with at least one of individual cells, groups of cells, portion of cells and nerve fibres of the neuroretina; and

at least one ground return electrode (14, 14a) for connection with the electrical source,

characterized in that the at least one ground return electrode (14, 14a) is configured to be disposed or implanted at an extended location spaced or remote from the stimulating electrode (23b, 27) for transretinal stimulation of the neuroretina, the at least one stimulating electrode and the at least one ground return electrode being disposed on the opposite sides of the neuroretina.

2. The device (10) of claim 1, wherein the at least one stimulating electrode (23b, 27) and the at least one ground return electrode (14, 14a) are configured to be disposed or implanted on opposite sides of the neuroretina.
3. The device (10) of claim 1, wherein the at least one stimulating electrode (23b, 27) is provided in a stimulating electrode unit (12), and the at least one ground return electrode (14, 14a) is provided in a ground return electrode unit (16).
4. The device (10) of any one of the preceding claims, wherein the at least one ground return electrode (14, 14a) is configured to be disposed on a sclera surface on an outside of the eye.
5. The device (10) of any one of the preceding claims, wherein the at least one stimulating electrode (23b) comprises a plurality of stimulating electrodes (22), and wherein the stimulating electrodes (23b, 27) are

configured to be disposed close to, or in contact with, an epiretinal side of the neuroretina.

6. The device (10) of any one of the preceding claims, wherein the at least one stimulating electrode (23b) comprises a plurality of stimulating electrodes (22) configured in an array (12).
7. The device (10) of claim 6, wherein the stimulating electrode array (12) is fabricated on a web (17), the web (17) preferably comprising silicon, and/or the web (17) preferably comprising a biocompatible material.
8. The device (10) of any one of the preceding claims, wherein at least one ground return electrode (14, 14a) is fabricated on a web, and wherein the web optionally comprises silicon.
9. The device (10) of any one of the preceding claims, wherein the device includes the electrical source to provide electrical current to the at least one stimulating electrode (23b, 27); and/or wherein the electrical source is adapted to provide stimulation from outside the eye; and/or wherein the electrical source is adapted to transmit a signal in a wireless fashion to the eye; and/or wherein the electrical source is adapted to use radio-frequency (RF) to send signals to a coil located in the eye that is in communication with the stimulating and ground electrodes.
10. The device (10) of any one of the preceding claims, wherein the ground return electrode (14, 14a) is supported and positioned on an extension from the portion of the device (10) incorporating the at least one stimulating electrode (23b, 27).
11. The device (10) of any one of the preceding claims, wherein the at least one ground return electrode (14, 14a) is configured to be disposed between the sclera and the choroid; or wherein the at least one ground return electrode (14, 14a) is configured to be disposed between a choriocapillaris and a retinal pigment epithelium; or wherein the at least one ground return electrode (14, 14a) is configured to be disposed in a subretinal space of the neuroretina; or wherein the at least one ground return electrode (14, 14a) is configured to be disposed in a vitreous cavity of the eye; or wherein the at least one ground return electrode (14, 14a) is configured to be disposed within a lens capsule of the eye; or wherein the at least one ground return electrode (14, 14a) is configured to be disposed in an anterior chamber of the eye.

Patentansprüche

1. Künstliche Retinavorrichtung (10) zur elektrischen Stimulation einer Neuroretina eines Auges zum Erzeugen künstlicher Sehkraft, die künstliche Retinavorrichtung (10) umfassend:
 - mindestens eine Stimulationselektrode (23b, 27) zur Verbindung mit einer elektrischen Quelle, wobei die mindestens eine Stimulationselektrode (23b, 27) eingerichtet ist, für elektrischen Kontakt mit mindestens einem aus individuellen Zellen, Gruppen von Zellen, einem Teil von Zellen und Nervenfasern der Neuroretina angeordnet oder implantiert zu sein; und
 - mindestens eine Masseelektrode (14, 14a) zur Verbindung mit der elektrischen Quelle, **dadurch gekennzeichnet, dass** die mindestens eine Masseelektrode (14, 14a) eingerichtet ist, für transretinale Stimulation der Neuroretina in einer ausgedehnten Position beabstandet oder entfernt von der Stimulationselektrode (23b, 27) angeordnet oder implantiert zu sein, wobei die mindestens eine Stimulationselektrode und die mindestens eine Masseelektrode an den entgegen gesetzten Seiten der Neuroretina angeordnet sind.
2. Vorrichtung (10) nach Anspruch 1, wobei die mindestens eine Stimulationselektrode (23b, 27) und die mindestens eine Masseelektrode (14, 14a) eingerichtet sind, an entgegen gesetzten Seiten der Neuroretina angeordnet oder implantiert zu sein.
3. Vorrichtung (10) nach Anspruch 1, wobei die mindestens eine Stimulationselektrode (23b, 27) in einer Stimulationselektrodeneinheit (12) vorgesehen ist, und wobei die mindestens eine Masseelektrode (14, 14a) in einer Masseelektrodeneinheit (16) vorgesehen ist.
4. Vorrichtung (10) nach einem der vorhergehenden Ansprüche, wobei die mindestens eine Masseelektrode (14, 14a) zum Anordnen auf einer Oberfläche der Sklera außerhalb des Auges eingerichtet ist.
5. Vorrichtung (10) nach einem der vorhergehenden Ansprüche, wobei die mindestens eine Stimulationselektrode (23b) eine Mehrzahl von Stimulationselektroden (22) umfasst, und wobei die Stimulationselektroden (23b, 17) eingerichtet sind, nahe zu, oder in Kontakt mit, einer epiretinalen Seite der Neuroretina angeordnet zu sein.
6. Vorrichtung (10) nach einem der vorhergehenden Ansprüche, wobei die mindestens eine Stimulationselektrode (23b) eine Mehrzahl von in einem Array (12) konfigurierten Stimulationselektroden (22) umfasst.
7. Vorrichtung (10) nach Anspruch 6, wobei das Stimulationselektrodenarray (12) auf einer Folie (17) hergestellt ist, wobei die Folie (17) bevorzugt Silikon umfasst, und/oder wobei die Folie (17) bevorzugt ein biokompatibles Material umfasst.
8. Vorrichtung (10) nach einem der vorhergehenden Ansprüche, wobei die mindestens eine Masseelektrode (14, 14a) auf einer Folie (17) hergestellt ist, und wobei die Folie optional Silikon umfasst.
9. Vorrichtung (10) nach einem der vorhergehenden Ansprüche, wobei die Vorrichtung die elektrische Quelle zum Versorgen der mindestens einen Stimulationselektrode (23b, 27) mit elektrischem Strom beinhaltet; und/oder wobei die elektrische Quelle zum Bereitstellen von Stimulation von außerhalb des Auges ausgebildet ist; und/oder wobei die elektrische Quelle zum drahtlosen Übertragen eines Signals zum Auge ausgebildet ist; und/oder wobei die elektrische Quelle ausgebildet ist zum Verwenden von Radiofrequenzen (RF) zum Senden von Signalen zu einer im Auge positionierten Spule, welche in Kommunikation mit den Stimulations- und Masseelektroden ist.
10. Vorrichtung (10) nach einem der vorhergehenden Ansprüche, wobei die Masseelektrode (14, 14a) an einer Verlängerung des die mindestens eine Stimulationselektrode (23b, 27) enthaltenden Teils der Vorrichtung (10) getragen und positioniert ist.
11. Vorrichtung (10) nach einem der vorhergehenden Ansprüche, wobei die mindestens eine Masseelektrode (14, 14a) eingerichtet ist, zwischen der Sklera und dem Choroid angeordnet zu sein; oder wobei die mindestens eine Masseelektrode (14, 14a) eingerichtet ist, zwischen einer Choriokapillaris und einem retinalen Pigmentepithelium angeordnet zu sein; oder wobei die mindestens eine Masseelektrode (14, 14a) eingerichtet ist, in einem subretinalen Raum der Neuroretina angeordnet zu sein; oder wobei die mindestens eine Masseelektrode (14, 14a) eingerichtet ist, in einer Glaskörperkammer des Auges angeordnet zu sein; oder wobei die mindestens eine Masseelektrode (14, 14a) eingerichtet ist, in einer Linsenkapsel des Auges angeordnet zu sein; oder wobei die mindestens eine Masseelektrode (14, 14a) eingerichtet ist, in einer vorderen Kammer des Auges angeordnet zu sein.

Revendications

1. Dispositif de rétine artificielle (10) pour stimuler électriquement une neuro-rétine d'un oeil afin de produire une vision artificielle, le dispositif de rétine artificielle (10) comprenant :
 - au moins une électrode de stimulation (23b, 27) pour une connexion avec une source électrique, dans laquelle ladite au moins une électrode de stimulation (23b, 27) est configurée de façon à être disposée ou implantée pour un contact électrique avec au moins un élément parmi des cellules individuelles, des groupes de cellules, une partie de cellules et des fibres nerveuses de la neuro-rétine ; et
 - au moins une électrode de retour de terre (14, 14a) pour une connexion à la source électrique, **caractérisé en ce que** ladite au moins une électrode de retour de terre (14, 14a) est configurée de façon à être disposée ou implantée à un endroit étendu espacé ou éloigné de l'électrode de stimulation (23b, 27), afin de permettre une stimulation trans-rétinienne de la neuro-rétine, ladite au moins une électrode de stimulation et ladite au moins une électrode de retour de terre étant disposées sur des côtés opposés de la neuro-rétine.
2. Dispositif (10) selon la revendication 1, dans lequel ladite au moins une électrode de stimulation (23b, 27) et ladite au moins une électrode de retour de terre (14, 14a) sont configurées de façon à être disposées ou implantées sur des côtés opposés de la neuro-rétine.
3. Dispositif (10) selon la revendication 1, dans lequel ladite au moins une électrode de stimulation (23b, 27) est fournie dans une unité d'électrode de stimulation (12) et ladite au moins une électrode de retour de terre (14, 14a) est fournie dans une unité d'électrode de retour de terre (16).
4. Dispositif (10) selon l'une quelconque des revendications précédentes, dans lequel ladite au moins une électrode de retour de terre (14, 14a) est configurée de façon à être disposée sur une surface du blanc de l'oeil à l'extérieur de l'oeil.
5. Dispositif (10) selon l'une quelconque des revendications précédentes, dans lequel ladite au moins une électrode de stimulation (23b) comprend une pluralité d'électrodes de stimulation (22) et dans lequel les électrodes de stimulation (23b, 27) sont configurées de façon à être disposées près de, ou en contact avec un côté épitrétinien de la neuro-rétine.
6. Dispositif (10) selon l'une quelconque des revendications précédentes, dans lequel ladite au moins une électrode de stimulation (23b) comprend une pluralité d'électrodes de stimulation (22) configurées selon un réseau (12).
7. Dispositif (10) selon la revendication 6, dans lequel le réseau d'électrodes de stimulation (12) est fabriqué sur une toile (17), la toile (17) comprenant de préférence du silicium, et/ou la toile (17) comprenant de préférence un matériau biocompatible.
8. Dispositif (10) selon l'une quelconque des revendications précédentes, dans lequel ladite au moins une électrode de retour de terre (14, 14a) est fabriquée sur une toile et dans lequel la toile comprend éventuellement du silicium.
9. Dispositif (10) selon l'une quelconque des revendications précédentes, dans lequel le dispositif comprend la source électrique permettant de fournir du courant électrique à ladite au moins une électrode de stimulation (23b, 27) ; et/ou dans lequel la source électrique est apte à fournir une stimulation depuis l'extérieur de l'oeil ; et/ou dans lequel la source électrique est apte à transmettre un signal sans fil à l'oeil ; et/ou dans lequel la source électrique est apte à utiliser la radiofréquence (RF) pour envoyer des signaux à une bobine située dans l'oeil, qui est en communication avec les électrodes de stimulation et de terre.
10. Dispositif (10) selon l'une quelconque des revendications précédentes, dans lequel l'électrode de retour de terre (14, 14a) est supportée et positionnée sur une extension partant de la partie du dispositif (10) intégrant ladite au moins une électrode de stimulation (23b, 27).
11. Dispositif (10) selon l'une quelconque des revendications précédentes, dans lequel ladite au moins une électrode de retour de terre (14, 14a) est configurée de façon à être disposée entre le blanc de l'oeil et la choroïde ; ou dans lequel ladite au moins une électrode de retour de terre (14, 14a) est configurée de façon à être disposée entre une couche chorio-capillaire et un épithélium de pigment rétinien ; ou dans lequel ladite au moins une électrode de retour de terre (14, 14a) est configurée de façon à être disposée dans un espace sous-rétinien de la neuro-rétine ; ou dans lequel ladite au moins une électrode de retour de terre (14, 14a) est configurée de façon à être disposée dans une cavité vitrée de l'oeil ; ou dans lequel ladite au moins une électrode de retour de terre (14, 14a) est configurée de façon à être disposée dans une capsule du cristallin de l'oeil ; ou

dans lequel ladite au moins une électrode de retour de terre (14, 14a) est configurée de façon à être disposée dans une chambre antérieure de l'oeil.

5

10

15

20

25

30

35

40

45

50

55

FIG. 1A

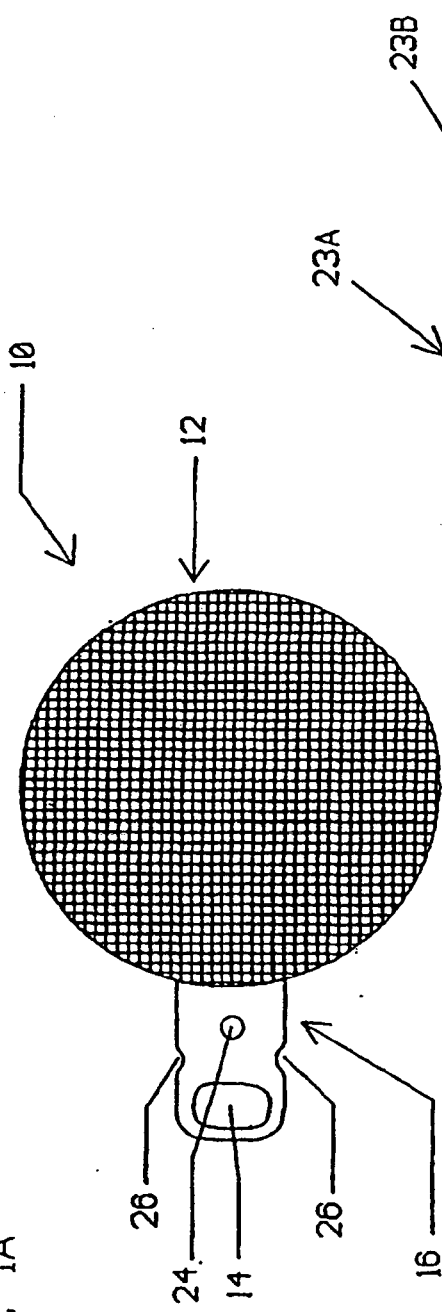

FIG. 1B

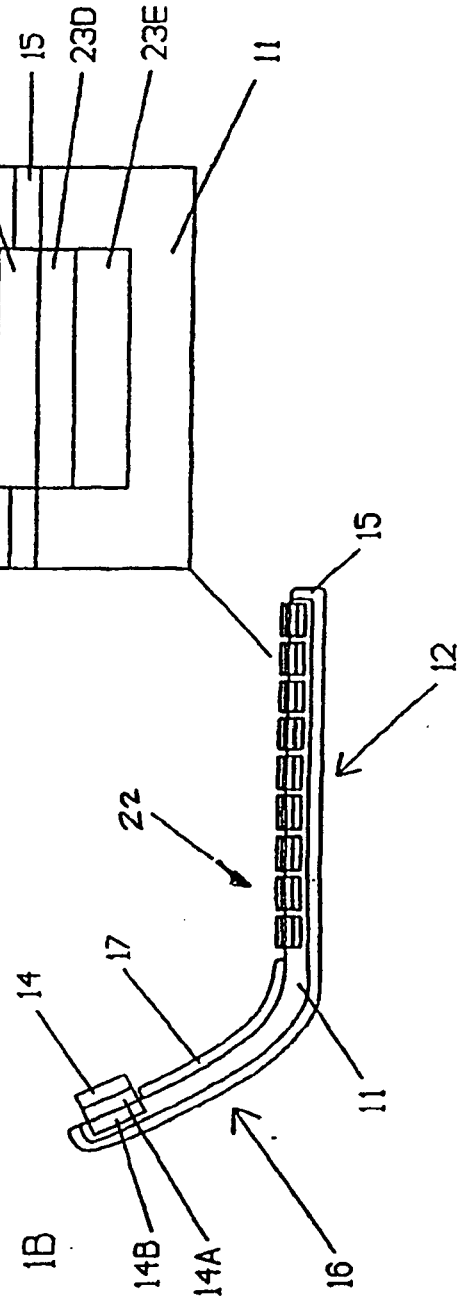

FIG. 2A

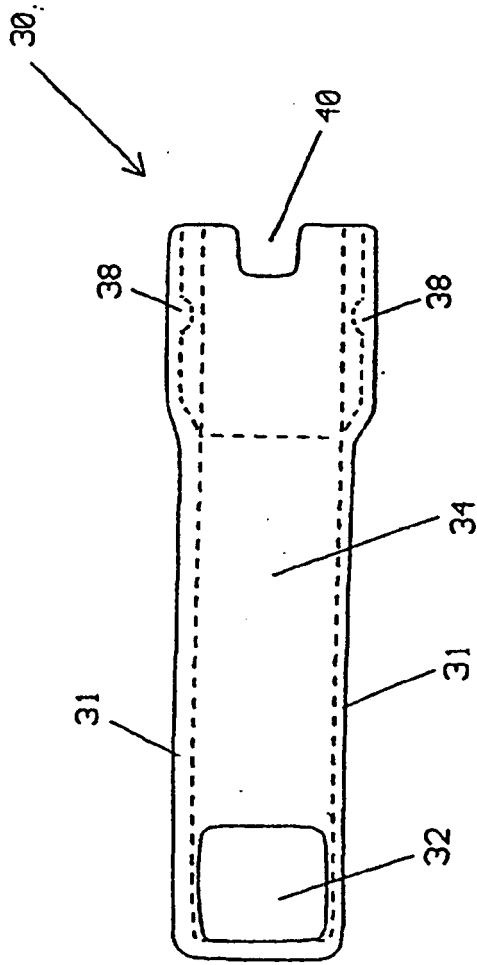

FIG. 2B

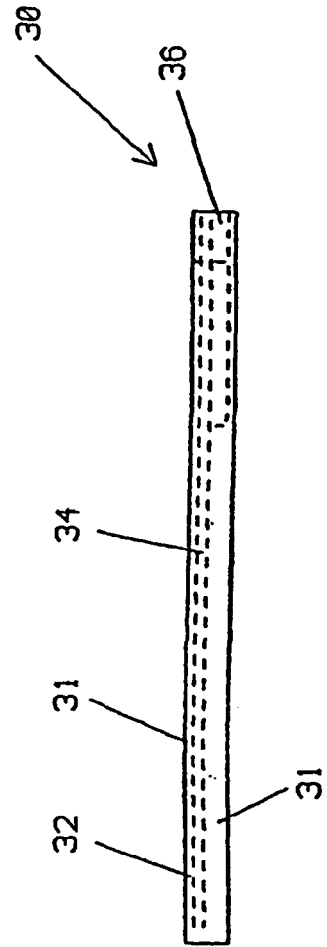

FIG. 3

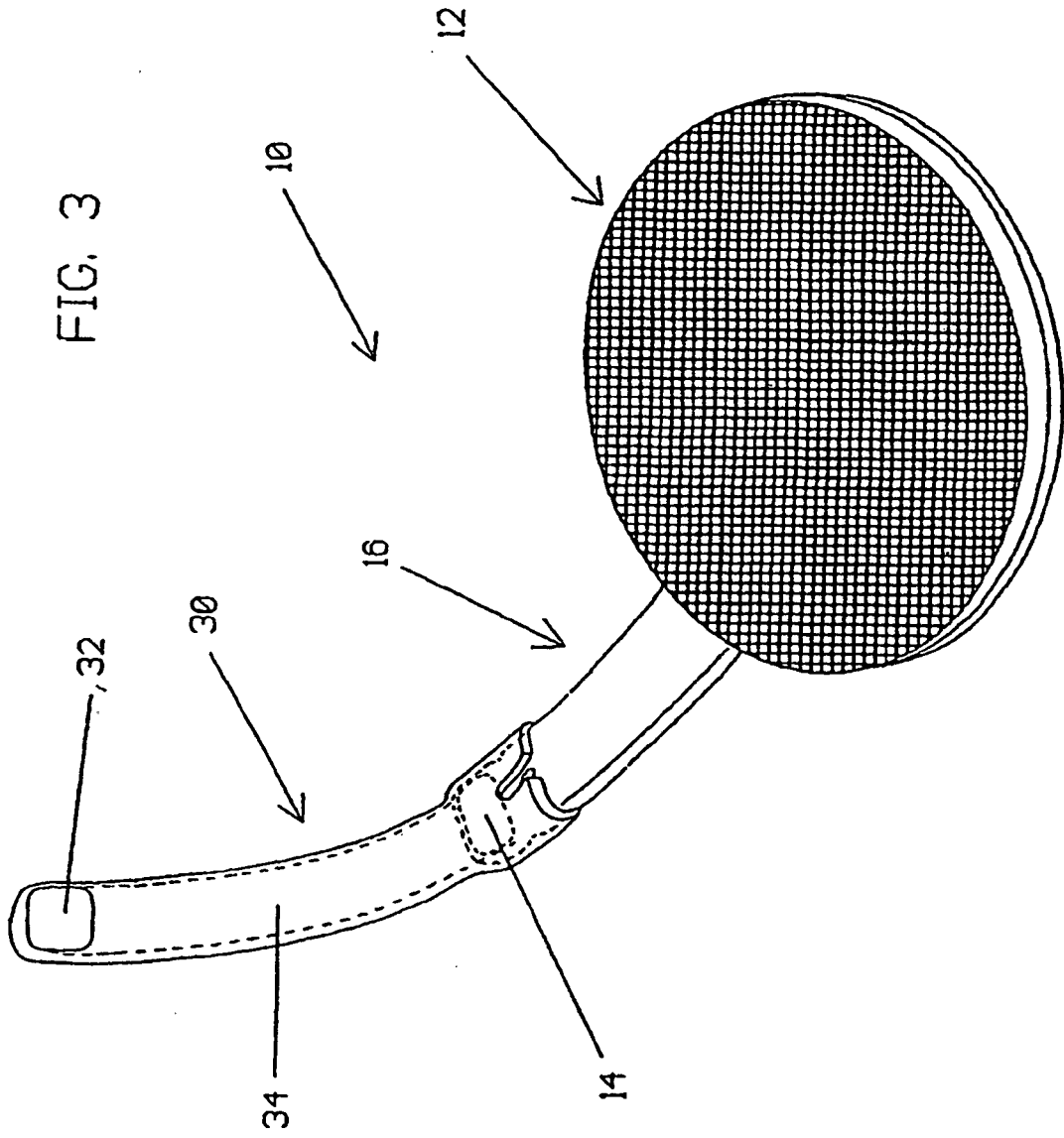

FIG. 4

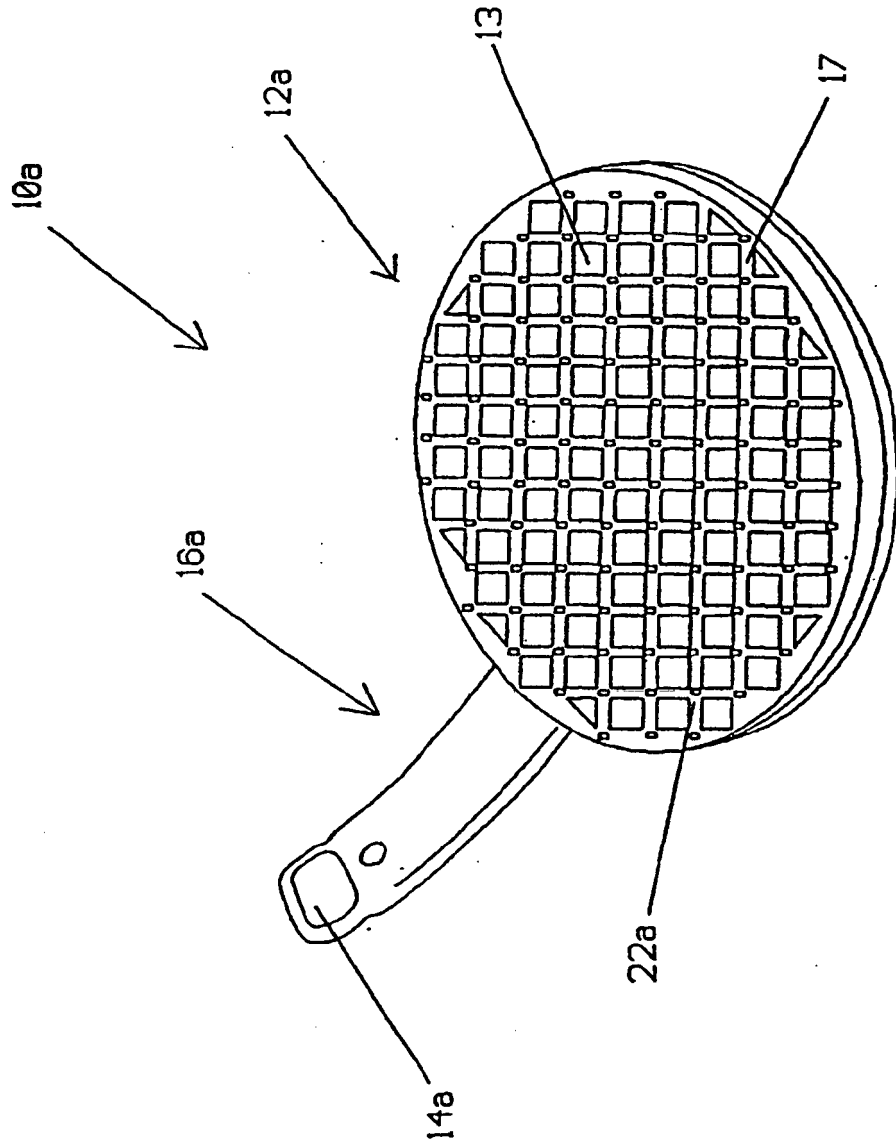

FIG. 4A

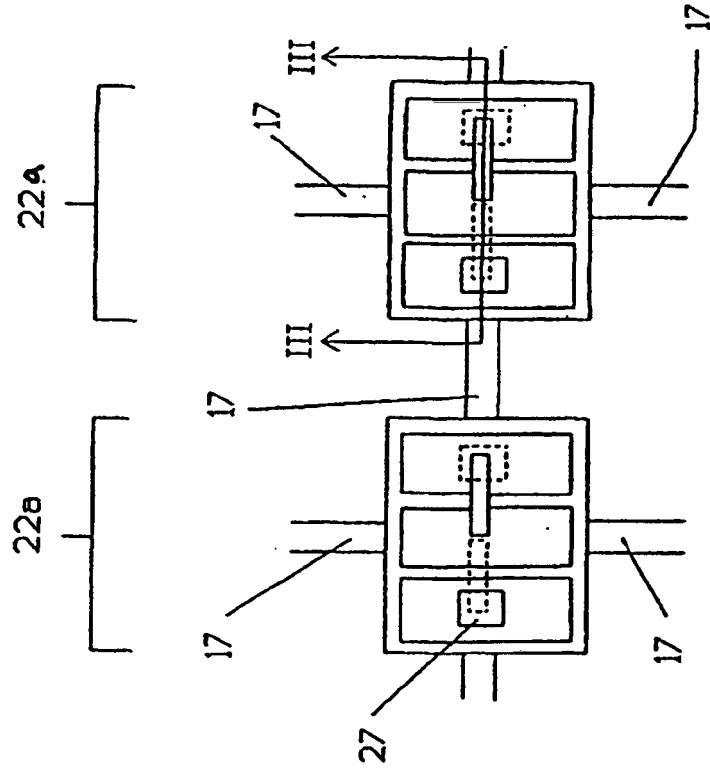

FIG. 4B

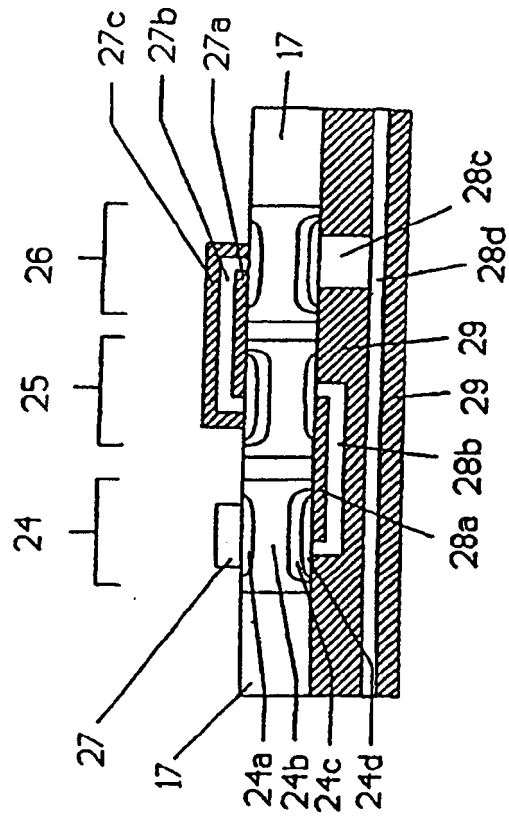

FIG. 5

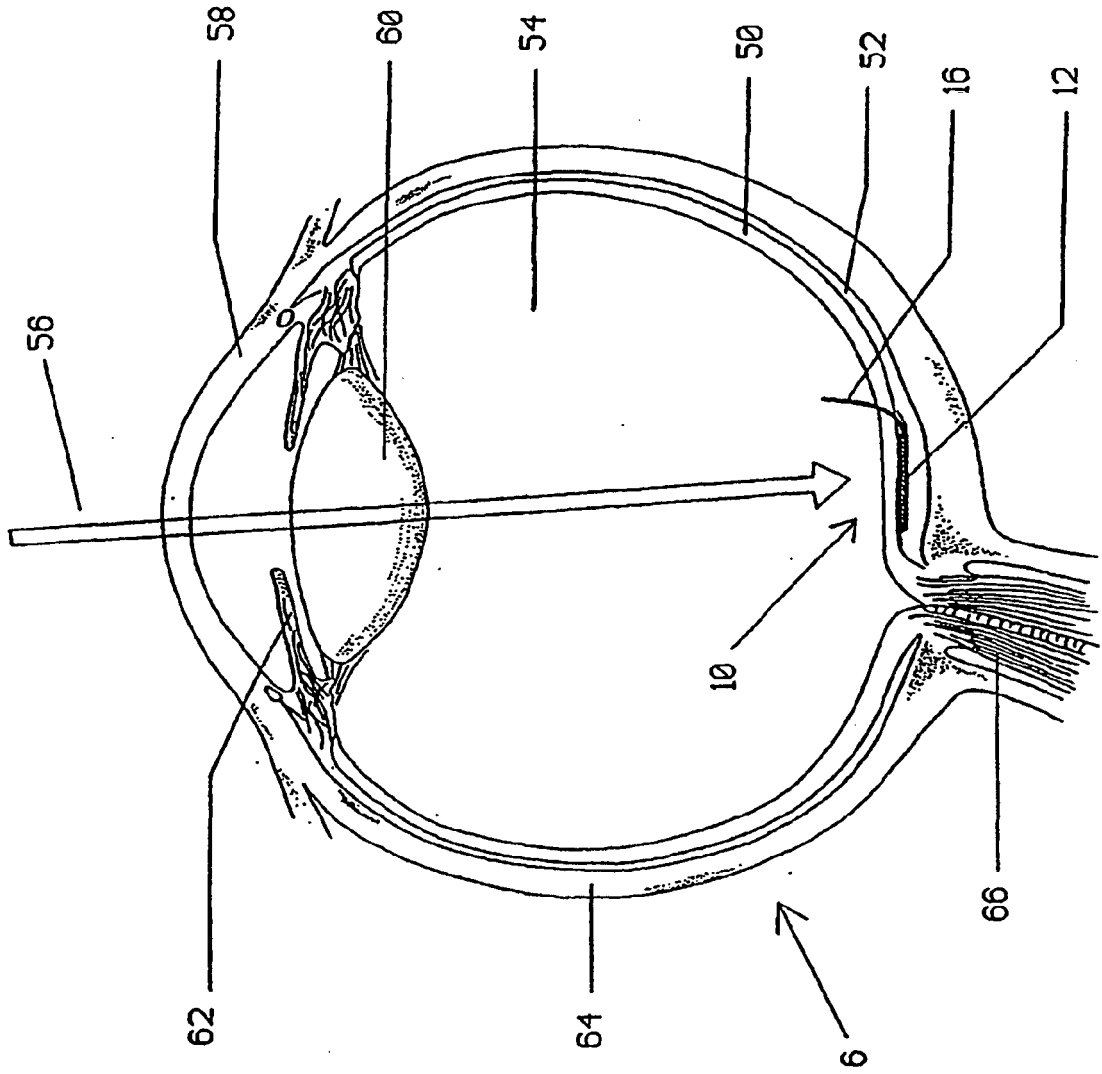

FIG. 6

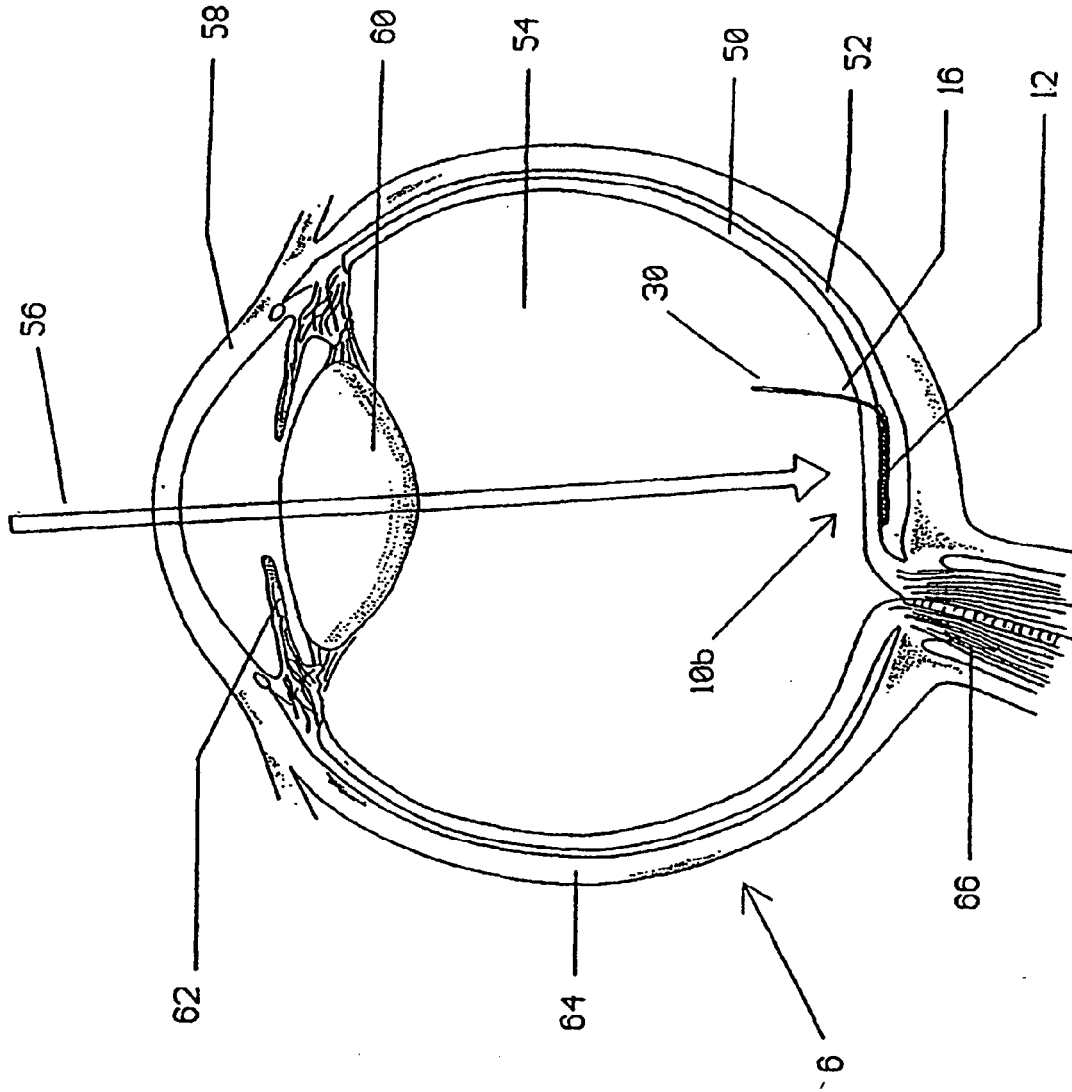

FIG. 7

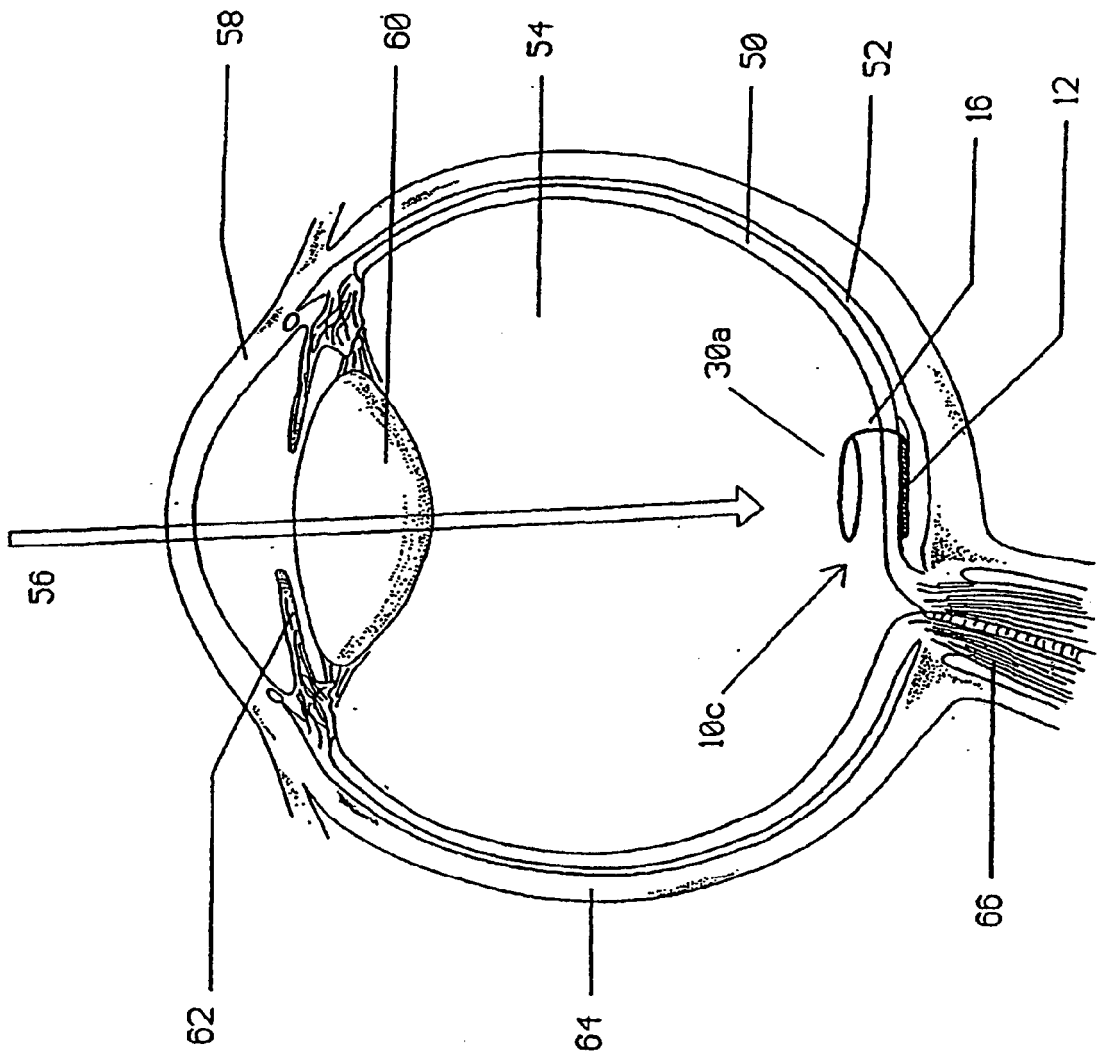

FIG. 8

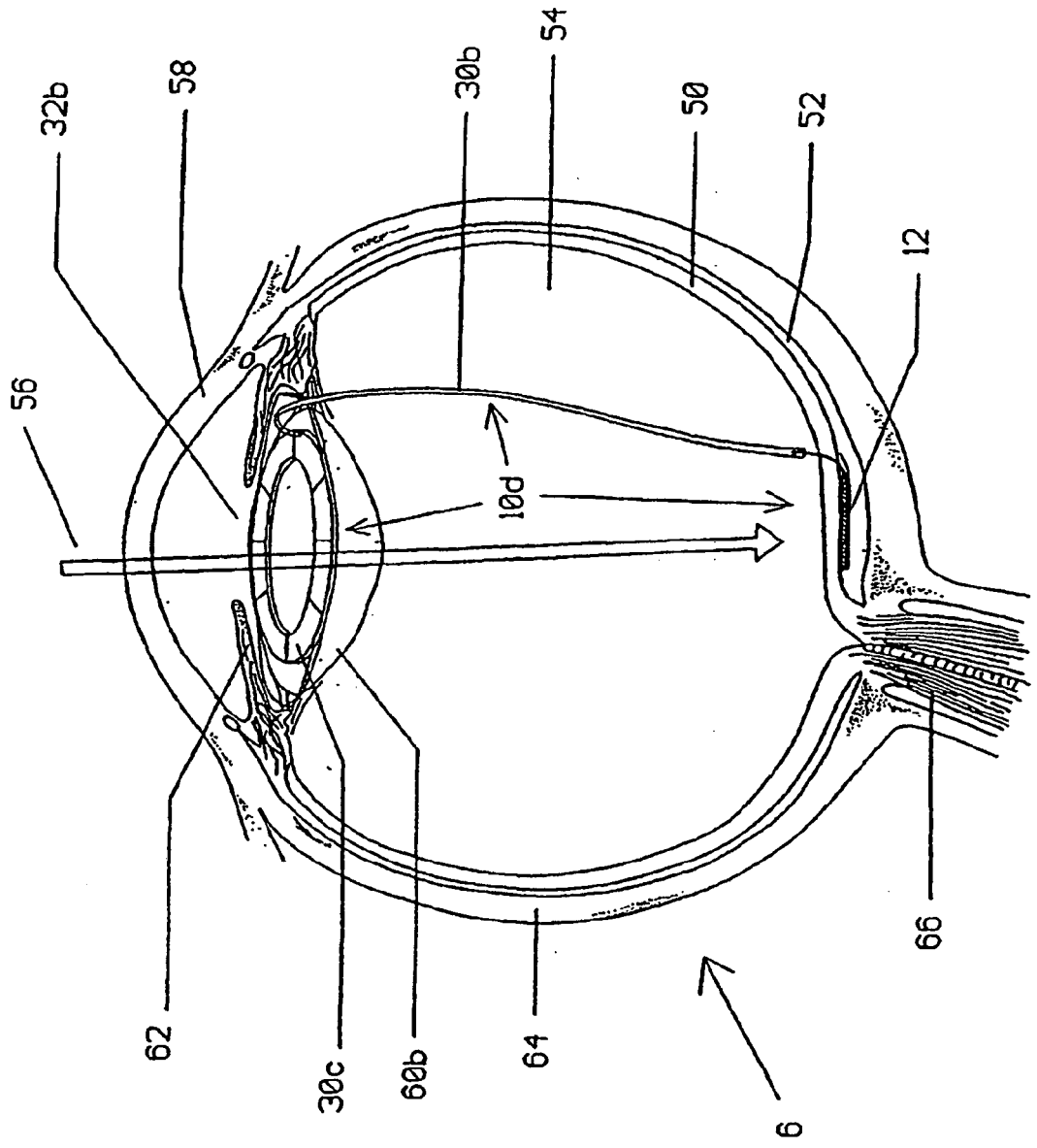
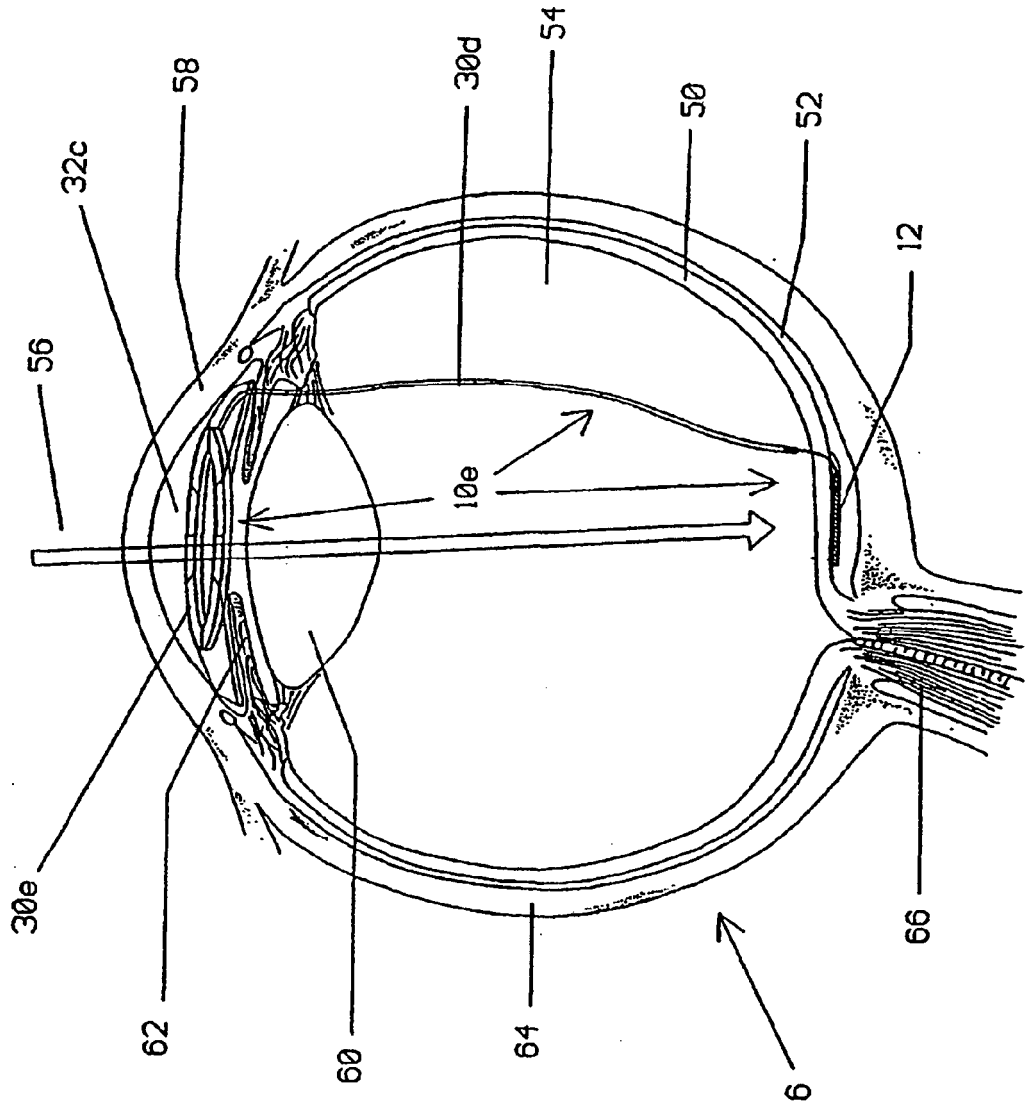

FIG. 9



REFERENCES CITED IN THE DESCRIPTION

This list of references cited by the applicant is for the reader's convenience only. It does not form part of the European patent document. Even though great care has been taken in compiling the references, errors or omissions cannot be excluded and the EPO disclaims all liability in this regard.

Patent documents cited in the description

- US 4628933 A [0004]