

(19)



(11)

EP 2 301 507 A1

(12)

EUROPEAN PATENT APPLICATION

(43) Date of publication:

30.03.2011 Bulletin 2011/13

(51) Int Cl.:

A61H 1/00 (2006.01)

A63B 19/04 (2006.01)

A63B 71/00 (2006.01)

(21) Application number: **09171515.1**

(22) Date of filing: **28.09.2009**

(84) Designated Contracting States:

**AT BE BG CH CY CZ DE DK EE ES FI FR GB GR
HR HU IE IS IT LI LT LU LV MC MK MT NL NO PL
PT RO SE SI SK SM TR**

Designated Extension States:

AL BA RS

(72) Inventor: **Mazzamurro, Giovanni**
20090 Buccinasco (IT)

(74) Representative: **Pfau, Anton Konrad**
Grünecker Kinkeldey
Stockmair & Schwannhäuser
Anwaltssozietät
Leopoldstrasse 4
80802 München (DE)

(71) Applicant: **Mazzamurro, Giovanni**
20090 Buccinasco (IT)

(54) Equipment for vestibular stimulation and/or treatment of neuromuscular dysfunctions

(57) The present invention relates to an equipment 100 for vestibular stimulation and/or for the therapeutic treatment of neuromuscular dysfunctions and comprises a supporting structure 1 and a tilting or swinging element or pendulum 30 adapted to tilt and/or swing on a rotational axis 2a substantially horizontal. The equipment according to the present invention comprises moreover support-

ing and/or fixing means adapted to fix a person or user 14 (for instance a person with disabilities or affected by neuromuscular dysfunctions) to said tilting or swinging element 30 so that said person or user can be fixed to said tilting or swinging element 3 in a position in which said person or user appears to be lying supine on his own back on a plane substantially perpendicular to said rotational axis 2a.

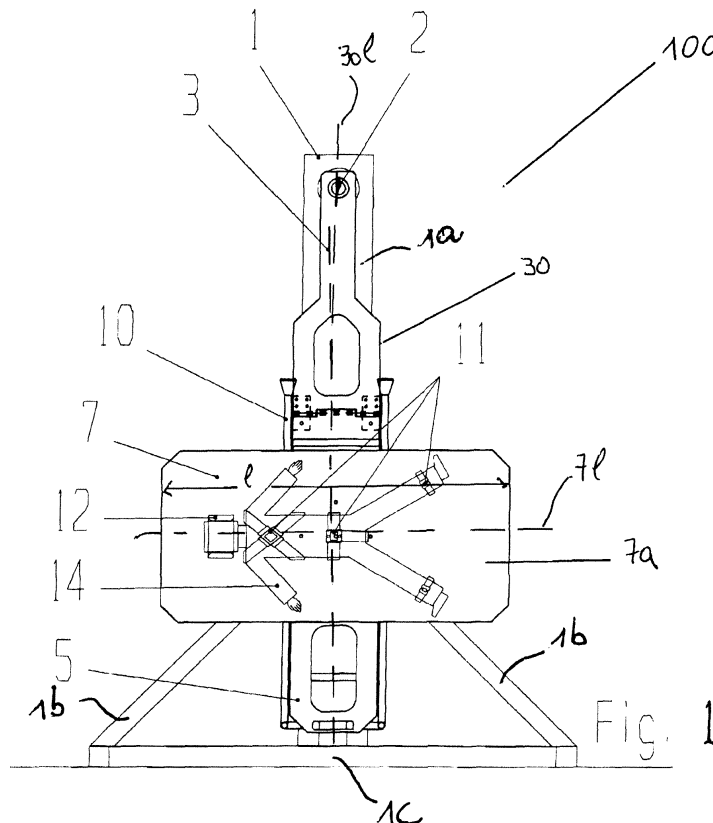

EP 2 301 507 A1

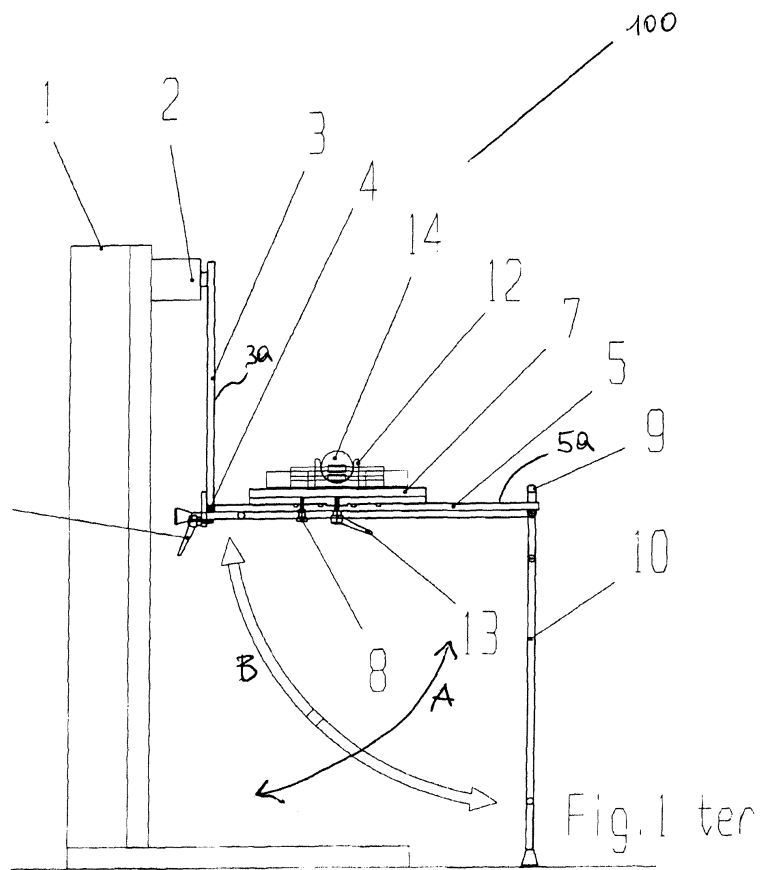
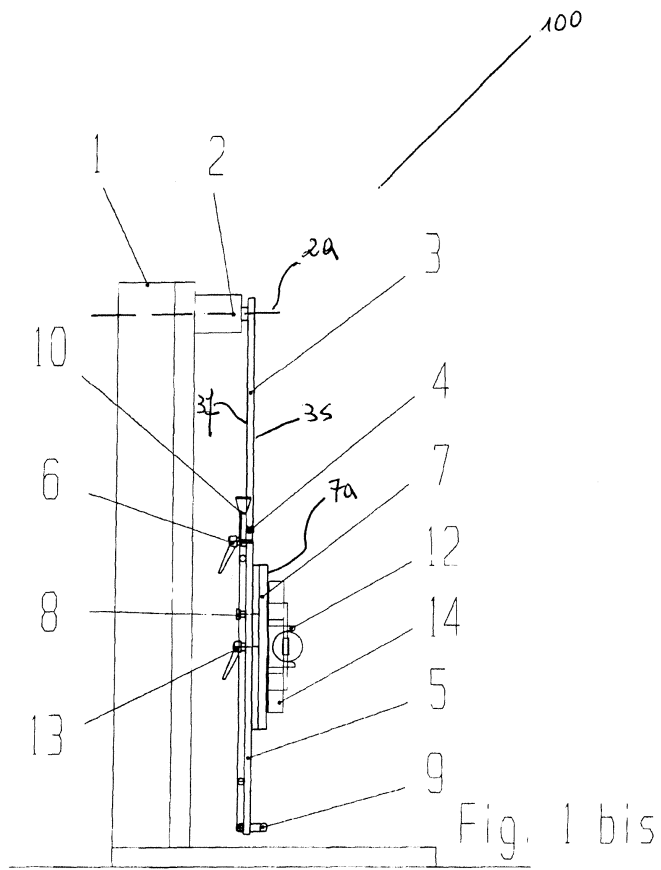

Description

TECHNICAL FIELD OF THE PRESENT INVENTION

[0001] The present invention relates to the field of treatment and/or therapy of neuromuscular dysfunctions. In particular, the present invention relates to the field of the vestibular stimulations.

[0002] In more detail, the present invention relates to the field of exercises (training) to be executed by persons affected by neuromuscular dysfunctions and/or disabilities such as, for instance, persons or people with disabilities or handicaps, in particular children and/or infants. The present invention relates therefore to equipment and/or a facility and/or a device or tool adapted to allow to the subjects identified above to execute exercises or training suitable for the therapeutic treatment of neuromuscular dysfunctions, equilibrium and/or body balance, as well as for problems related to difficult or restrained walking or motion as well as to similar problems.

[0003] Still in more detail, the present invention relates to an equipment or facility or device adapted to tilt or swing like a pendulum and suitable to allow the exercises or training identified above to be executed. By means of the equipment or facility according to the present invention, the exercises to be executed for therapeutic treatment of the above-identified problems may be executed in a simple and efficient manner.

BACKGROUND ART

[0004] It is known that a person or people affected by neuromuscular dysfunctions or disabilities more or less serious or critical such as, for instance, persons with disabilities or handicapped or even affected by restricted or difficult body balance and/or motion, may enjoy benefits and/or advantages from the execution of specific exercises and/or training, directed to the therapeutic treatment of said problems. However, it is also known that these subjects or people very often experience great difficulties in executing individually and autonomously the exercises or training which have been suggested to them; in some cases, it is even impossible for these persons or people to execute the prescribed exercises or training. The kind or nature of the problems these persons are affected by limits in fact their motion capabilities and therefore limits their autonomy and their capability or possibilities to execute in an appropriate manner the exercises or training indicated by the therapy.

[0005] In the recent past, particular attention has therefore been dedicated to identifying or finding out the most efficient exercises or training suitable to be executed for the therapeutic treatment of neuromuscular dysfunctions. The same attention and efforts have also been dedicated to the realization of equipments or facilities suitable for helping both persons affected by the above-identified problems and their assistants, such as therapists or the like who are requested to assist handicapped peo-

ple during the execution of the therapeutic exercises or training.

[0006] If, on one hand, it can be said that the exercises or training suggested or proposed by the medical research for the therapy of neuromuscular dysfunctions and/or for vestibular stimulations have provided quite satisfying results, on the other hand it has to be noted that, unfortunately, many of said exercises are still very difficult to be executed. In several cases, it is still necessary for persons with disabilities or handicapped persons to be assisted by a therapist during the execution of the exercises; this particularly depends independently thereon whether the exercises are executed with or without using equipments or facilities adapted to this end. In other cases, although quite promising and efficient exercises or training have been identified, it has still not been possible to realize and/or provide equipments or facilities adapted to allow such exercises to be executed.

[0007] As to the equipments, facilities, devices or tools suggested or recommended in the recent past for executing therapeutic exercises, it has to be noted that said equipments or facilities are very often affected by several problems and/or disadvantages. For instance, the equipment or facilities suggested in the past are quite complicated and can be realized and/or produced only at very high costs, so that this equipment is not suitable to be used by private persons or people; the equipments or facilities identified above are therefore put at the disposal of the patients only in therapeutic centers or premises such as public centers or the like.

[0008] However, several problems arise from these situations, in particular due to the difficulties for the persons or people who need to execute such exercises, to be transported to said specialized centers. In many cases, the families and/or derivatives of persons affected by neuromuscular dysfunctions do not have vehicles or cars or equivalent means at their disposal suitable for transporting these persons, so that the need arises to make use of ambulances or rescue vehicles and/or the like.

[0009] Serious problems arise also due to the dimensions of the equipment or facilities known in the art since these cumbersome or large facilities or equipment are difficult to be located; cumbersome or heavy equipment or facilities or devices need to be located in correspondingly large rooms or spaces, which are however often not available in private premises (houses or flats) so that these facilities or equipments may be installed and/or located only in therapeutic centers that are adequately equipped.

[0010] Finally, the facilities or devices or equipments which are available at present do not allow the most efficient exercises or training suggested by the medical research in the recent past to be adequately executed.

OBJECT OF THE PRESENT INVENTION

[0011] The present invention is based on the general consideration according to which very promising results

in both the therapeutic treatments of the neuromuscular dysfunctions and in the field of vestibular stimulations can be obtained by means of exercising during which the person subjected to the therapeutic treatment (for instance persons or people with disabilities or handicapped or even with body balance and/or body motion problems, in particular children and infants) are subjected to a tilting and/or swinging movement similar to that of a pendulum and/or a child's swing.

[0012] A further important consideration on which the present invention is based relates to the fact that the efficiency and/or effectiveness of such a tilting and/or swinging motion depends on the position assumed by the person during such a motion; in particular, the effectiveness may be improved if the person is somehow "suspended" from a tilting or swinging element rather than seated on or supported by same. Moreover, the effectiveness may even be further improved if the person will be suspended in a position in which the same person appears to be lying down, however not on a horizontal surface, but rather on a vertical plane or surface.

[0013] In other words, in the position suggested by the present invention, the person to be treated will be suspended from a tilting swinging element in such a way that a longitudinal plane crossing the body of said person (and extending from the head to the feet of said person so as to ideally divide the person not into left and right parts comprising the left and right legs and arms of the person, respectively, but rather a frontal or forward portion comprising the face and groin and a rear portion comprising the back of the head and the gluteuses of said person) will be oriented substantially vertically or perpendicularly to the axis of rotation of the pendulum to which the same person will be suspended.

[0014] In other words, if it is imagined that a person has to be positioned on the equipment and/or facility and/or device and/or tool according to the present invention in the position which reveals to be the most effective in terms of the results to be obtained, it has to be imagined that said person is first laid down so as to be supine or to lie on his back on a horizontal plane substantially rectangular (thus comprising two long sides or edges and two short sides or edges), that the person is subsequently fixed to said plane and that said plane is finally rotated about 90°, either on one of its long sides or edges, or even one of its short sides or edges. In this way, the person will then be suspended from the plate (now oriented vertically) with his back and rear portions of his body being ideally in contact with a fictitious vertical surface; in this way, it will therefore be possible to say that the person will be disposed so as to "lie on his back" with respect to a vertical plane or surface.

[0015] A further consideration on which the present invention is based relates to the fact that the use of the equipment and/or facility according to the present invention can be rendered easily equipped or integrated with the equipment or facility with means adapted to simplify the positioning or fixation of the person subjected to the

therapy of the tilting or swinging element of said equipment or facility. In fact, in this way, also people without specific preparation or education in the field of therapeutic treatments (for instance, the relatives or parents of a person with an handicap) will be able to provide valid help during this positioning and dispositioning of the person on the tilting or swinging element, and in particular without any need to be assisted by therapists or tutors or qualified assistants. A further consideration on which the present invention is based relates to the fact that the equipment or facility according to the present invention can be used for the therapeutic treatment of different dysfunctions, in particular when said facility, device or tool is equipped with means adapted to allow for the modification or changing of the position of the person to be treated with respect to the tilting or swinging element, in particular as a function of the therapeutic treatments to be performed and/or of the exercises or training to be executed.

[0016] On the basis of the general considerations stated above, a first embodiment of the present invention relates to equipment or a facility, device or tool for vestibular stimulation and/or for therapeutic treatment of neuromuscular dysfunctions, comprising a supporting structure and a tilting or swinging element rotatably fixed to said supporting structure in such a way that said tilting or swinging element is allowed to tilt and/or swing on a rotational axis substantially horizontal, said equipment or facility comprising furthermore holding and/or fixing means adapted to fix a person to said tilting or swinging element so that this person will appear to be lying on his own back or supine with respect to a surface or plane substantially perpendicular to said rotational axis.

[0017] According to a further embodiment, the present invention relates to equipment or a facility for vestibular stimulation and/or therapeutic treatment of neuromuscular dysfunctions comprising a holding or supporting element anchored or fixed to said tilting or swinging element, with said holding or supporting element defining a supporting or holding plane substantially perpendicular to said rotational axis, and wherein said fixing means are adapted to fix said person to said supporting element so that this person will appear to be lying on his own back or supine with respect to said supporting or holding plane.

[0018] According to a further embodiment of the equipment or facility according to the present invention, said supporting or holding element is rotatably fixed to said tilting or swinging element so as to be adapted to be fixed and locked to said tilting or swinging element in different and/or predefined positions.

[0019] According to a further embodiment of the present invention, said tilting or swinging element comprises a first portion and a second portion, said second portion being rotatably fixed to said first portion, said second portion being, in particular, rotatable between a first position and a second position in which said holding or supporting plane of said holding or supporting element is oriented so as to be substantially parallel to a horizontal

plane, so as to render it easy fixing said person to said supporting or holding element.

[0020] Further embodiments of the present invention are defined in the dependent claims.

DESCRIPTION OF THE DRAWINGS

[0021]

Figure 1 relates to a frontal view of an embodiment of the equipment or facility according to the present invention;

Figure 1bis relates to a side view of the embodiment of the equipment according to the present invention depicted in Figure 1;

Figure 1ter relates to a side view of the equipment according to the present invention during the step of fixing a person or subject to said equipment;

Figure 2 relates to a front view of the equipment according to the present invention during the step of fixing a person or a subject to said equipment;

Figure 3 relates to a front view of the equipment according to the present invention during its tilting or swinging motion;

Figure 4 relates to a front view of a further embodiment of the equipment and/or facility according to the present invention;

Figure 5 relates to a front view of the embodiment of the equipment or facility according to the present invention depicted in Figure 4 and during the tilting or swinging motion.

DETAILED DESCRIPTION OF THE PRESENT INVENTION

[0022] The present invention will be explained in the following by means of the following description of those embodiments of the present invention depicted in the drawings. It should, however, be noted that the present invention is not limited to the particular embodiments described in the following and depicted in the drawings; it should rather be noted that the embodiments described in the following and depicted in the drawings clarify some aspects of the present invention, the scope of which is therefore defined by the claims.

[0023] The present invention therefore has to be considered as comprising all those variations and/or amendments of the embodiments described and depicted in the drawings which are clearly and unambiguously appreciated by those skilled in the art.

[0024] In the enclosed drawings identical or corresponding component parts as well as identical or corre-

sponding features of the equipment or facility according to the present invention are identified by the same reference numerals.

[0025] In Figures 1 and 1bis, the embodiments of the equipment according to the present invention depicted therein are identified by the reference numeral 100. Said equipment (in the following also referred to as facility, device or tool) comprises a supporting structure 1, for instance made of metal, wood, plastic or other similar rigid materials. Said supporting structure comprises, in particular, a main element 1 a extending substantially vertically from which two further elements or feet 1 b extend so as to obliquely slope toward the bottom, with said two further elements or feet 1 b being joined to each other by means of a base element 1 c lying on the bottom; said base element 1 c joins in particular, the end portions of the elements or feet 1 b opposite to the end portions of said elements or feet 1 b which are joined to the main element 1 a. The dimensions of the base element 1 c are such as to counterbalance or exert adequate resistance to the gravity force exerted by a person or user 14 fixed to the equipment or facility, thus avoiding the equipment or facility to turn or knock over. A tilting or swinging element 30 is fixed (suspended) to the supporting structure 1, said tilting or swinging element 30 being rotatably fixed to the supporting element 1 by means of a rotating pin or bolt 2. The tilting or swinging element 30 is therefore adapted to tilt and/or swing (see Figure 3 in this respect) and therefore to rotate on the longitudinal axis of symmetry 2a of the pin or bolt 2 which will be in the following also referred to as the rotating axis. The tilting or swinging element 30 will therefore move like a pendulum or child's swing on the plane of Figure 1. It will therefore clearly appear from the description given above that the dimension and/or extension and/or amplitude of the oscillations can be modified according to the needs and/or circumstances, for instance pushing the tilting or swinging element or pendulum 30, or even by means of electromechanical means or devices (for instance an electrical motor) adapted to act on the rotating pin or bolt 2 and/or on the tilting or swinging element 30. Depending on the needs and/or circumstances, it will also be possible to rotate the tilting or swinging element or pendulum 30 around 360° on the rotational axis 2a. Fixed or applied to the tilting or swinging pendulum or element 30 there is also a supporting or holding element substantially flat 7 which defines a supporting or holding surface also flat 7a and oriented substantially perpendicularly with respect to the rotational axis 2a. The supporting or holding surface 7a will be therefore substantially parallel to the plane of Figure 1 and will lie on a plane substantially vertical. Fixing means 11 such as, for instance, belts, braces or clamps are furthermore provided for the purpose of fixing a user (for instance a person affected by neuromuscular dysfunctions or with disabilities, a handicap or even with body balance or body motion problems, particularly a child or infant) to the supporting or holding element 7. In the embodiment depicted in Figures 1 and

1bis, said supporting or holding element 7 comprises a plate (for instance made of wood, metal, plastic or other similar rigid materials) fixed or applied to the tilting or swinging element or pendulum 30. To this end, several solutions will be possible between those known to the skilled person. For instance, for the purpose of fixing the plate 7 to the tilting or swinging element or pendulum 3, it will be possible to use screws or bolts or the like, or even hooks adapted to be engaged into corresponding seats or holes formed in the plate 7. Moreover, it will be possible to use one or more tips or shafts or the like. For the purpose of realizing and/or assembling the equipment according to the present invention, it will be sufficient for the table 7 to be fixed or applied to the tilting or swinging element or pendulum 30 in a reliable and safe manner so as to avoid, particularly during the use of the equipment 100 the plate 7 getting accidentally disengaged or disconnected from the tilting or swinging element or pendulum 30. In particular, the application or safety fixation of the plate 7 to the tilting or swinging element or pendulum 30 will be ensured by means of locking or fixing means 13 (for instance screwed or threaded means) adapted to bring the surface of the blade 7 opposite to the supporting or holding surface 7a into contact or engagement with the surface 3s of the tilting or swinging element or pendulum 30, opposite the surface 3f of said swinging or tilting element or pendulum 30, which is located in front of (so as to face toward) the supporting structure 1. Still, with reference to the fixing or locking means 11 adapted to fix a user 14 to the plate 7, it has to be noted that said locking or fixing means may be completed by adding to the belts or laces 11 described above, supporting means extending from said supporting or holding surface 7a of the plate 7. Such additional supporting or holding means can, for instance, comprise cushions, protrusions, projections or protuberances 12 adapted to exert adequate resistance against the weight of the user 14 and/or to avoid accidental and/or inconvenient movements or dislocations, during use of the equipment 100, of legs, arms or body portions of the same user 14. For instance, in Figure 1, cushions 12 are depicted between which the head of the user will be positioned for the purpose of holding the head of said user 14 in place, thus, contrasting the weight of the head and its eventual accidental and inconvenient movement or dislocation. Of course, said cushions or protrusions can be moved so as to be located and positioned in different positions so as to match the dimensions and/or the size of the user 14. In the case of users affected by particularly serious dysfunctions, it will even be possible to provide cushions or protrusions adapted to support and/or sustain other body portions in addition to the head of the users, such as for instance the chest, the groin or the like.

[0026] With reference to Figure 1, it has, in particular, to be noted the position assumed by the user 14 during the use of the equipment or facility 100 and, therefore, during the execution of the exercises of training for therapeutic treatment. It will be noted that the plate 7 has a

shape substantially rectangular with a length l; the user 14 is moreover suspended to the plate 7 by means of the belts or laces 11 (and eventually, as stated above, by means of auxiliary cushions or protrusions or the like.

Moreover, if a plane of symmetry 7l of the user 14 is now imagined, with said plane of symmetry 7l dividing ideally the body of said user 14 into symmetric and substantially identical portions, with a first portion comprising the left leg and the left arm (in Fig. 1ter located above the plane of symmetry 7l), along with a second portion substantially symmetric and specular to said first portion and, therefore, comprising the right leg and arm of the user 14 (located below the plane of symmetry 7l in Figure 1ter) it will be possible to appreciate that said plane of symmetry 7l will be substantially horizontal and, therefore, substantially parallel to the rotational axis 2a. In other words, the situation will correspond to a situation, wherein the user 14 lies on a bed, the supporting surface of which is not horizontal, but rather oriented vertically, and in which the back, the gluteus and the heels of the user 14 lie on said vertical holding or supporting surface 7a. For the sake of clarity and conciseness, in the following, the position of the user 14 fixed to the holding or supporting table 7 as explained above will be referred to as a horizontal or supine position with respect to a vertical plane, thus meaning that those body portions of the user, which normally come into contact with a flat supporting surface oriented horizontally when the same user lies on its own back in a supine position (for instance the nape, the shoulders, the gluteus and the heels during sleeping) will be located on an ideal plane or surface substantially vertical.

[0027] In the following, with reference to Figures 1ter and 2, further features and/or component parts of the equipment or facility, according to the present invention will be described; in Figures 1ter and 2, those features or component parts described above with reference to Figures 1 and 1b are identified by the same reference numerals.

[0028] With reference, in particular, to Figure 1ter, it has to be noted that the tilting or swinging element or pendulum 30 of the equipment 100, according to the embodiment of the present invention depicted therein comprises two parts or portions, in particular, a first part or portion 3a and a second part or portion 5. The first part or portion 3a is rotatably fixed to the pin or bolt 2 as described above (and, therefore, in such a way that the tilting or swinging element of pendulum 30 is allowed to tilt and/or to swing on a plane perpendicular to the plane of Figure 1), while the second part or portion 5 is rotatably fixed to said first part or portion 3a. In more detail, the second part or portion 5 may be rotated with respect to the first part or portion 3a as indicated by the arrow A in Figure 1ter and, therefore, between a first position (represented in Figure 1b, in which the top or frontal surface 5a of the part or portion 5 lies substantially on a vertical plane along with the surface 3s of the tilting or swinging element of pendulum 30) and a second position (Figure 1 ter) in which the top or front surface 5a of the part or

portion 5 results to be disposed substantially horizontal, so as to form or define an angle substantially of 90° with the surface 3s of the tilting or swinging element or pendulum 30. The possibility of rotating the part of portion 5 with respect to the part of portion 3a as depicted in Figure 1ter is obtained by means of rotating means comprising, for instance, one or more hinges disposed between the part or portion 3a and the part or portion 5. Moreover, locking or fixing means 6 (for instance threaded or screwing means) are also provided for the purpose of fixing or locking the part or portion 5 with respect to the part or portion 3a alternatively in the positions depicted in Figure 1bis and Figure 1ter, respectively. It has, moreover, to be noted that the supporting or holding element or plate 7 is applied or fixed to the second part or portion 5 of the tilting or swinging element or pendulum 30; it results, therefore, that by rotating the part or portion 5 with respect to the part or portion 3a of the pendulum 30 until the position depicted in Figure 1ter is reached (i.e. with the part or portion 5 being disposed substantially horizontally) also the supporting or holding element or plate 7 fixed to same will be oriented and/or disposed in a position substantially horizontal. By disposing the part or portion 5 and, therefore, the supporting or holding plate 7 in the position depicted in Figure 1ter, fixing the user 14 to said plate 7 will be simplified, so that it will be possible for said user to first sit on said plate (eventually using auxiliary means such as for instance a staircase or ladder case or the like) and finally to lie down on said plate 7 (with his face facing toward the top). Once the fixation of the user 14 to the plate 7 by means of the belts or laces 11 has been completed, the portion or part 5 of the tilting or swinging element or pendulum 30 can be brought back to the position depicted in Figure 1bis in which, as clarified above, the supporting or holding surface 7a of the plate 7 will be oriented substantially vertically or perpendicularly to the rotational axis 2a. For the purpose of simplifying (and/or rendering easier) the rotation of the part or portion 5 with respect to the part of portion 3a of the tilting or swinging element 3 between the two positions depicted in Figures 1bis and 1ter, respectively, said part of portion 5 will be equipped with auxiliary means 9, such as for instance one or more handles or the like adapted to be used by a therapist or even a person requested to assist a user 14 during execution of the exercises or training, for the purpose of rotating the part or portion 5 between the position depicted in Figure 1bis and the position depicted in Figure 1ter (thus, so as to win the gravitational force arising due to the weight of the part or portion 5 and of the part or portions applied or fixed to same (the plate 7)), as well as for bringing back the part or portion 5 into the position of Figure 1bis, and thus accompanying or guiding said part or portion 5 during its rotational motion due to the gravitational force. Further support or holding means 10 are, moreover, provided for supporting or holding the part or portion 5 of the tilting or swinging element or pendulum 30, when said part or portion 5 is positioned horizontally as depicted in Figure 1ter;

said further supporting means are rotatably fixed to the end portion of the part or portion 5, on which also the handles 9 are fixed and/or located. Moreover, said additional supporting means are rotatably fixed to said part or portion 5 (for instance by means of hinges or the like); in Figure 1ter, the arrow B shows the direction of rotation of the additional supporting means 10 with respect to the part or portion 5 of the tilting or swinging element 30. It arises, therefore, that said additional supporting means 10 can be rotated between a first position (Figure 1ter) in which said additional supporting means 10 are oriented perpendicularly to the part or portion 5, and a second position (Figure 1bis) in which said additional supporting means 10 are oriented substantially so as to be parallel to said part or portion 5. The possibility to rotate the additional supporting means 10 with respect to the part or portion 5 allow to locate said supporting means 10 in the space between the supporting structure 1 and the tilting or swinging element 30 when the part or portion 5 of said tilting or swinging element is positioned with respect to the part or portion 3a of the same tilting or swinging element or pendulum 3 as depicted in Figure 1bis. This solution allows, therefore, to adequately use the space, thus preventing the dimension and/or the overall size of the equipment from increasing unduly. The additional supporting means 10 can, moreover, be equipped with anti-slipping means such as rubber cushions or the like fixed to the end portion of said additional supporting means or feet 10 and adapted to come into contact with the ground as depicted in Figure 1ter; said rubber cushions will be, therefore fixed to the end portion of the supporting means or feet 10 opposite to the end portion of said supporting means or feet 10 rotatably fixed to the portion or part 5 of the tilting or swinging element 30.

[0029] Figure 3, wherein as usual features or component parts of the equipment according to the present invention already described above with reference to other Figures are identified by the same reference numerals, shows clearly the motion and/or movement of the tilting or swinging element 30 during use of said equipment, and therefore, the movements or motions, which the user or person executing therapeutic exercises or training will be subjected to, for instance, exercises or training suitable for vestibular simulations, when using said equipment. It arises in fact clearly from Figure 3 that during the execution of these exercises, the tilting or swinging element 30 will rotate on the rotational axis 2a of the pin or bolt 2, thus tilting or swinging as indicated by the arrow X in the plane of Figure 3. The same applies also to the user 14, who will be therefore subjected to a tilting or swinging motion; it is this tilting or swinging motion, in particular in the case of a user fixed to the equipment 10 as depicted in Figure 3 (the position in which the user lies supine on his back with respect to a vertical plane), which has given the most promising results in the treatment and/or therapy of neuromuscular dysfunctions and/or in the field of the vestibular stimulations.

[0030] As anticipated above, the extension of the os-

cillations or swinging movement (arrow X) can be selected depending on the circumstances and/or the exigencies or needs of the user 14; the same applies also to the frequency of the oscillations, as well as to the duration of the tilting motion, which will be, therefore, selected and scheduled as a function of the exigencies of the user. It has, moreover, to be noted that the tilting or swinging element 30 (and therefore, the user 14) can be brought to swing and/or tilt either manually (for instance due to a therapist or assistant or another person pushing alternatively on the table 7 or even on the same tilting or swinging element 30) or by means of auxiliary means such as electromechanical means (electric motors or the like). Said electromechanical means will, therefore, further reduce the direct activity or intervention to be provided by tutors or therapists or the like and will allow selecting the extension, the amplitude, the frequency and the speed of the oscillations in a programmable and precise manner, for instance in the case of electromechanical means collected to an electric central unit or even to a small PC or computer on which several and different programs for corresponding several and different exercises have been loaded and saved.

[0031] The use of the equipment 100 can be summarized as follows. During a first step or phase, the portion 5 of the tilting or swinging element 30 will be rotated from its position depicted in Figure 1bis to its position depicted in Figure 1ter (which can be therefore referred to as an approach or entrance position in which the user 14 can be easily fixed to the supporting or holding plate 7). To this end, an assistant or tutor of the user will first of all proceed with releasing or unclamping or unlocking the part or portion 5 from the part or portion 3a of the tilting or swinging element 30, so as to allow said part or portion 5 to rotate on the rotating fixing means (hinges or the like) 4. The same tutor will, therefore, proceed with rotating the part or portion 5 in the direction indicated by the arrow A in Figure 1ter, in particular acting on said one or more handles 9; for completing the positioning of the part or portion 5, said user will further proceed with unlocking the additional supporting means or feet 10 so that same will be free to rotate in the direction indicated by the arrow B. Accordingly, said supporting means or feet 10 will get disposed and/or oriented substantially vertical, so as to support or sustain the part or portion 5 in the position depicted in Figure 1ter. With the part or portion 5 positioned as depicted in Figure 1ter, the same tutor or assistant will be able to help the user 14 become disposed on the plate 7; to this end, the same user can first sit down on the table 7 and subsequently dispose himself horizontally (so as to lie supine on his own back, thus facing towards the top). The user 14 will then be firmly fixed to the plate 7 by means of the belts or laces 11. The same tutor, acting again on the handles 9 will proceed with raising slightly the part or portion 5 of the tilting or swinging element 30, thus winning or overcoming the weight of the part or portion 5 and that of other portions or parts and of the user 14 disposed on it, and will bring

the additional supporting means or feet 10 back in their position depicted in Figure 1bis, in particular rotating same in the direction indicated by the arrow B in Figure 1ter. For instance, said additional supporting means or feet can be maintained parallel to the part or portion 5 of the tilting or swinging element 30 by means of elastic means such as clips or the like mounted or provided on said part or portion 5. Once said additional supporting means or feet 10 have been rotated back, the tutor will allow the part or portion 5 to rotate back in the direction indicated by the arrow A in Figure 1ter, thus, accompanying or guiding said part or portion 5 during its rotation, in particular acting on the handles or grips 9 until the part or portion 5 again reaches its position depicted in Figure 1bis. At this point, it is possible to activate the locking or clamping means 6 to firmly lock or fix the part or portion 5 to the part or portion 3a of the tilting or swinging element 30. Both the equipment or facility 100 and the user or person 14 will, therefore, be ready for the execution of the exercises or training for therapeutic treatment and/or vestibular stimulations. The exercises or training will, therefore, be executed bringing (manually or by means of auxiliary electromechanical means) the tilting or swinging element 3 and, therefore, the user or person fixed to the equipment or facility 100, to tilt and/or to swing. Still with reference to Figure 3, the different positions and/or heights the user can reach during the execution of the exercises, in particular the different positions or heights that the head of the user can reach during the tilting or swinging motion can be appreciated. The user will, therefore, have the feeling or sensation of being alternatively raised up and falling down toward the ground.

[0032] In the following, with reference to Figures 4 and 5, a further embodiment of the equipment according to the present invention will be described; as usual, in Figures 4 and 5, the features or component parts of the equipment already described above with reference to other Figures are identified by the same reference numerals.

[0033] The main difference between the embodiment of the equipment according to the present invention depicted in Figures 4 and 5 and the embodiment of the same invention depicted in Figures 1 to 3 relates to the fact that, in the embodiment depicted in Figures 4 and 5, the position and/or orientation of the element or supporting plate 7 with respect to the tilting or swinging element 3 can be modified depending on the exigencies and/or circumstances. The supporting or holding element or plate 7 can in fact be positioned with respect to the tilting or swinging element 3, either as depicted in Figures 1 to 3, and therefore with the longitudinal axis of symmetry 30I of said tilting element 30 being oriented substantially perpendicularly to the direction along which the long side or edges and/or the overall length l of the rectangular plate 7 extends, or as depicted in Figures 4 and 5, namely with the longitudinal axis of symmetry 30I of the tilting or swinging element 3 being oriented so as to be substantially parallel to the direction along which the long sides

or edges, and therefore the overall length l of said plate 7, extend. It will moreover be possible to fix or lock or clamp the supporting or holding plate 7 to the tilting or swinging element 3 in each intermediate position between the two positions described above, and therefore in such a way that the angle defined by the longitudinal axis of symmetry 30l of the tilting or swinging element 30 and the direction along which the long side or edges of the rectangular plate 7 be comprised between 0° and 90° . The locking or clamping of the plate 7 to the tilting or swinging element 30 in the desired position will be carried out acting on corresponding locking or clamping means 10, for instance the locking or clamping means described above.

[0034] Furthermore, as to the use and function of the equipment according to the embodiment of the present invention depicted in Figures 4 and 5, substantially the same considerations apply as stated with respect to the embodiment depicted in Figures 1 to 3; accordingly, for the sake of convenience and conciseness, a further detailed description of the use and function of the embodiment depicted in Figures 4 and 5 is herewith omitted.

[0035] It has therefore been demonstrated by means of the description given above that the equipment according to the present invention allows the expected goals to be reached and the problems posed to be overcome. In particular, the equipment according to the present invention allows the execution of exercises or training which have been revealed to be particularly advantageous and convenient in the therapeutic treatment of neuromuscular dysfunctions as well as of exercises suitable for vestibular stimulation, offering substantial improvement to subjects or persons with disabilities, handicaps or even persons affected by problems related to body motion and/or body balance. The equipment according to the present invention allows, moreover, a drastic reduction or limitation of the assistance to be performed by tutors or similar people requested or expected to assist a user during use of said equipment. The equipment may moreover be activated both manually (for instance by a tutor or assistant) and by means of auxiliary means such as, for instance, electromechanical means. The approach of a user to the equipment as well as his fixation to said equipment are furthermore drastically and significantly simplified. The equipment has reduced dimensions and can be assembled and/or realized at reasonable (or even low) costs. The equipment is therefore suitable to be used by families or private persons, as well to be used and assembled in domestic premises and not only in specialized centers. Finally, the equipment according to the present invention may be assembled and installed both indoors and outdoors.

[0036] Although the present invention has been clarified and explained by means of the above detailed description of its embodiments depicted in the drawings, the present invention is not at all limited to the embodiments described and depicted in the drawings. On the contrary, the present invention comprises all amend-

ments and/or improvements which will appear to be clear to those skilled in the art. For instance, it will be possible to avoid the use of the supported structure 1 and fix the rotating pin or bolt not to the said supporting structure, but to another structure already at the disposal, for instance to the ceiling or to a beam. In the same way, it will be possible to substitute the supporting or holding plate 7 with a less cumbersome and lighter frame. Alternatively, the supporting plate 7 can be avoided completely using belts or laces adapted to maintain a user in the position described above, namely a position in which a user appears to be lying down on a vertical plane. The scope of the present invention is therefore defined by the claims.

Claims

1. Equipment or facility or device (100) for vestibular stimulations and/or for the therapeutic treatment of neuromuscular dysfunctions, said equipment or facility or device (100) comprising a supporting structure (1) and a tilting or swinging element (30) rotatably fixed to said supporting structure (1) so that said tilting or swinging element (30) is allowed to tilt and/or swing on a rotation axis (2a) substantially horizontal, **characterized in that** said equipment or facility or device comprises, moreover, supporting and/or fixing means adapted to fix a person or user (14) to said tilting or swinging element (30) in a position such that said user or person appears to be lying supine on his own back on a plane substantially perpendicular to said rotation axis (2a).
2. Equipment or facility or device as claimed in claim 1, **characterized in that** said supporting and/or fixing means comprise a supporting or holding element (7) anchored to said tilting or swinging element (30), **in that** said supporting or holding element (7) defines a supporting or holding plane or surface (7a) substantially perpendicular to said axis of rotation (2a), and **in that** said fixing means are adapted to fix said person or user (14) to said supporting or holding element (7) in said position in which said person or user (14) appears to be lying supine on his own back with respect to said supporting or holding plane (7a).
3. Equipment or facility or device as claimed in claim 2, **characterized in that** said fixing means comprise belts or laces or the like (11) adapted to fix the legs and/or arms and/or head and/or similar body portions of said person or user (14) to said supporting or holding element (7).
4. Equipment or facility or device as claimed in one of claims 2 and 3, **characterized in that** said supporting or holding element (7) is rotatably fixed to said tilting or swinging element (30), so that said support-

ing or holding element (7) can be fixed, clamped or locked to said tilting or swinging element (30) in different and/or predefined positions.

- 5. Equipment or facility or device as claimed in claim 4, **characterized in** said supporting or holding element (7) has a shape substantially rectangular with two long sides or edges having a length l, **in that** said tilting or swinging element (30) comprises a longitudinal axis (30l) substantially perpendicular to said axis of rotation (2a), and **in that** said supporting or holding element (7) may be fixed to said tilting or swinging element (3) either in such a way that said longitudinal axis (30l) of said tilting or swinging element (30) results to be oriented perpendicularly with respect to the direction along which said two long sides or edges and said length l of said supporting or holding element (7) extend, or in such a way that said longitudinal axis (30l) of said tilting or swinging element (30) results to be oriented so as to be parallel to said direction along which said two long sides or edges and said length l of said supporting or holding element (7) extend.
- 6. Equipment or facility or device as claimed in one of claims 4 and 5, **characterized in that** the said equipment or facility or device (100) further comprises anchoring and/or locking and/or clamping means (13) adapted to anchor and/or lock and/or clamp said supporting elements (7) in different and/or predefined positions with respect to said tilting or swinging element (30).
- 7. Equipment or facility or device as claimed in one of claims 2 to 6, **characterized in that** said tilting or swinging element (30) comprises a first portion (3a) and a second portion (5), **in that** said second portion (5) is rotatably fixed to said first portion (3a) and **in that** said supporting or holding element (7) is rotatably anchored to said second portion (5) of said tilting or swinging element (3).
- 8. Equipment or facility or device as claimed in claim 7, **characterized in that** said second portion (5) of said tilting or swinging element (30) is adapted to be rotated with respect to said first portion (3) between a first and a second position and **in that**, with said second portion (5) of said tilting or swinging element (3) being located in said second position, said supporting or holding plane or surface (7a) of said supporting or holding element (7) results to be substantially parallel to a horizontal plane so as to simplify the fixation and the positioning of said person or user (14) to said supporting or holding element (7).
- 9. Equipment or facility or device as claimed in one of claims 7 and 8, **characterized in that** said equipment or facility or device (100) further comprises sup-

- porting means (10) adapted to support said second portion (5) of said tilting or swinging element (30) in said second position.
- 10. Equipment or facility or device as claimed in claim 9, **characterized in that** the said supporting means are rotatably fixed to said second portion (5) of said tilting or swinging element (30), and **in that** said supporting means (10) are adapted to be rotated with respect to said second portion (5) of said tilting or swinging element (30) between a first position and a second position in which said supporting means are oriented substantially perpendicularly with respect to said second portion (5) of said tilting or swinging element (30).
- 11. Equipment or facility or device as claimed in one of claims 1 to 10, **characterized in that** said tilting or swinging element (30) is adapted to tilt and/or to swing freely on said axis of rotation 2a.
- 12. Equipment or facility or device as claimed in one of claims 1 to 10, **characterized in that** the said equipment or facility or device (100) further comprises electromechanical means adapted to bring said tilting or swinging element (30) to tilt and/or to swing.

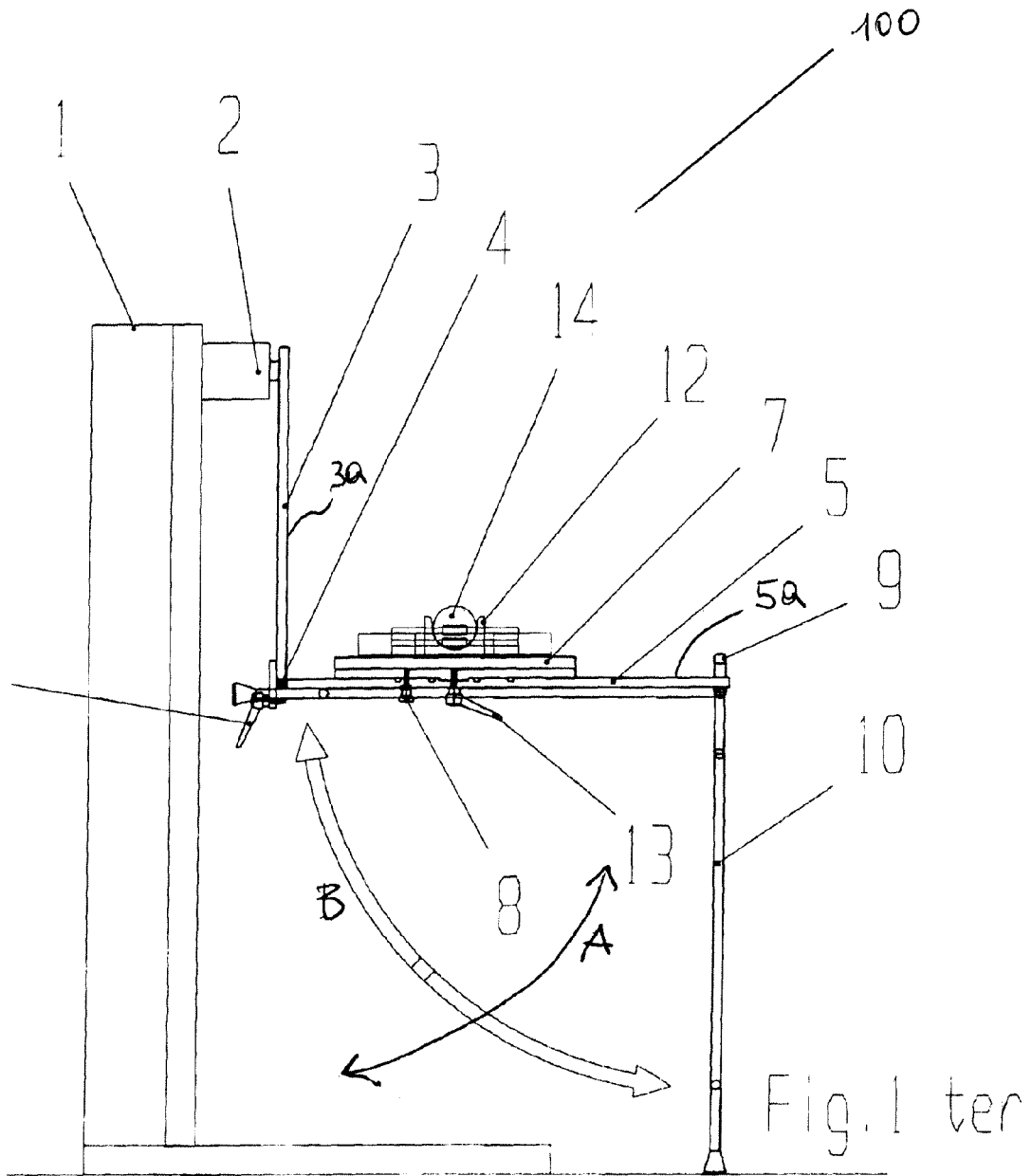

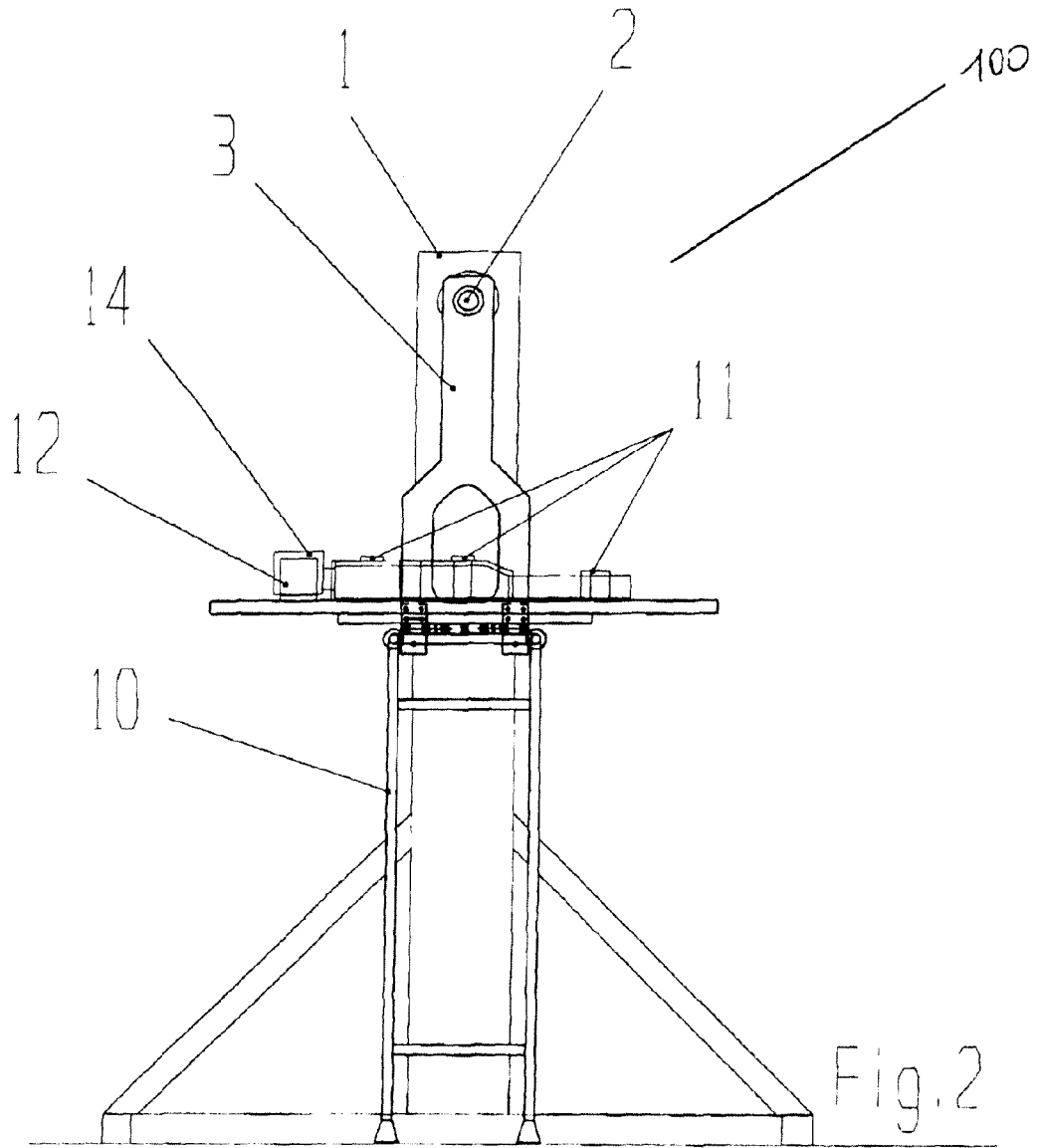

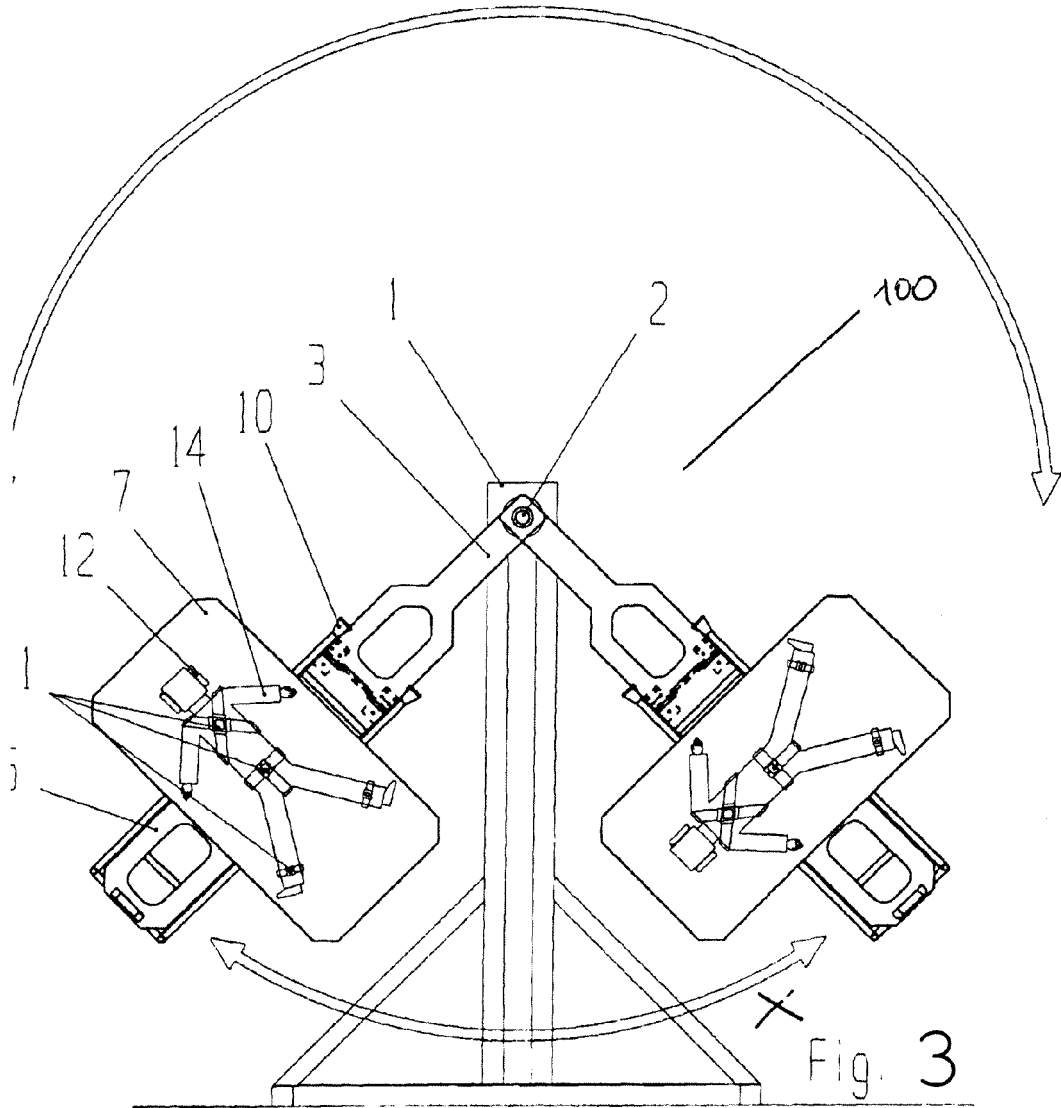

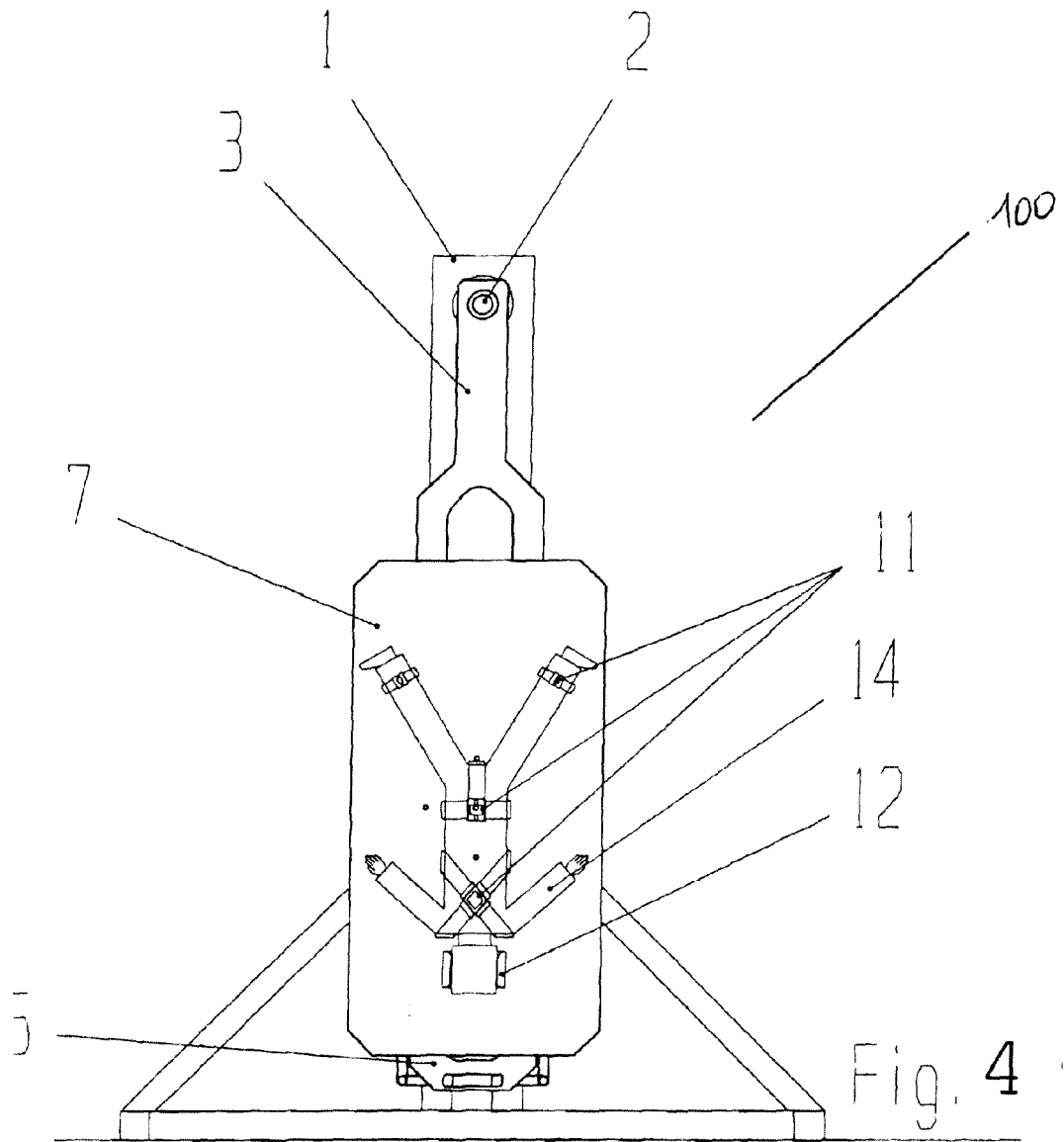

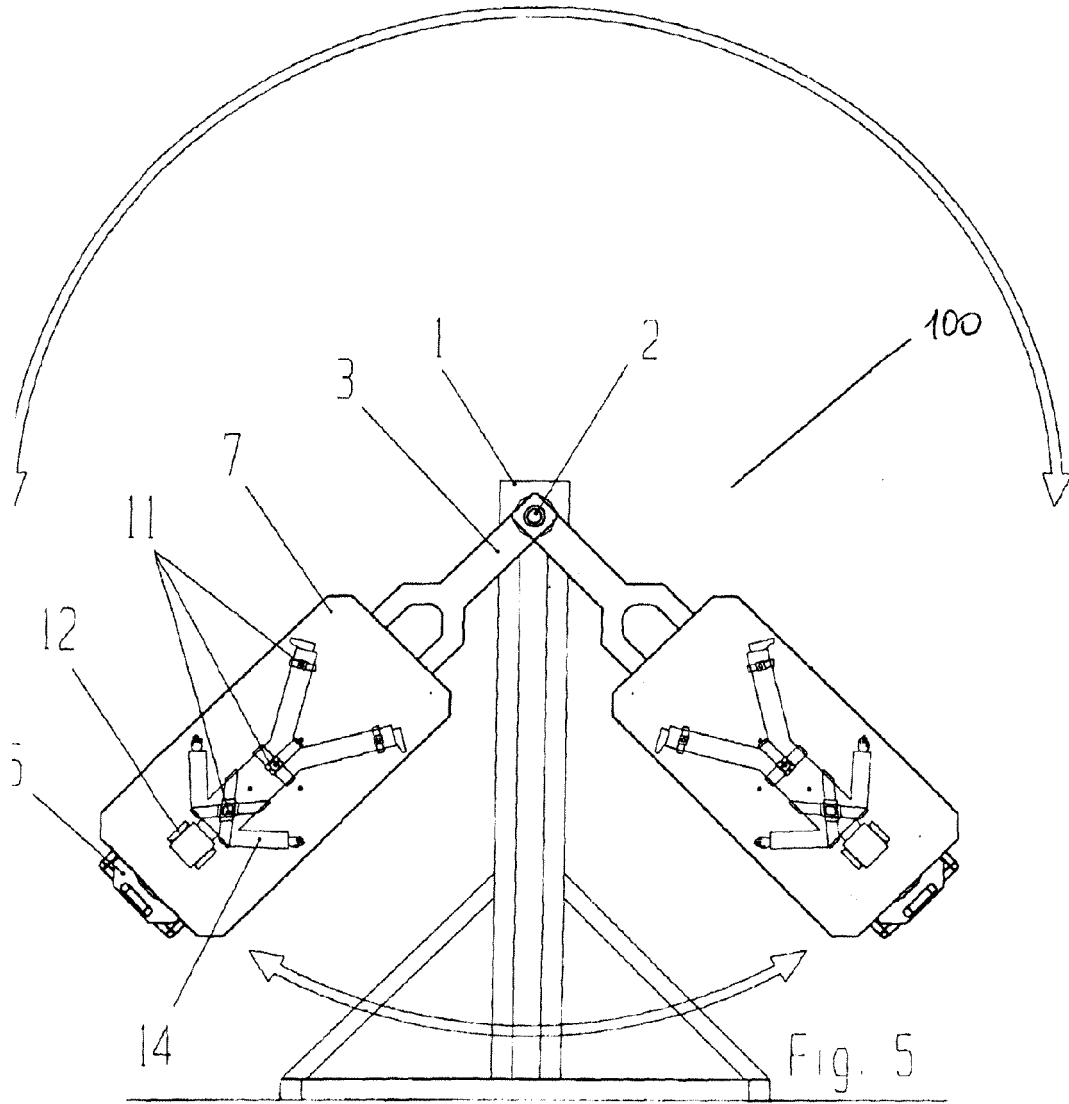



EUROPEAN SEARCH REPORT

Application Number
EP 09 17 1515

DOCUMENTS CONSIDERED TO BE RELEVANT			
Category	Citation of document with indication, where appropriate, of relevant passages	Relevant to claim	CLASSIFICATION OF THE APPLICATION (IPC)
X	WO 89/09040 A1 (FABER GERHART [DE]) 5 October 1989 (1989-10-05)	1-4,7,12	INV. A61H1/00
Y	* the whole document * -----	5-6,8-10	ADD. A63B19/04 A63B71/00
Y	US 2002/074457 A1 (BARUTT JOHN [US]) 20 June 2002 (2002-06-20)	5-6,8-10	
	* the whole document * -----		
X	US 2 193 154 A (AMILIO ANTINORI) 12 March 1940 (1940-03-12)	1-4,11	
	* the whole document * -----		
A	US 3 216 423 A (BLONSKY GEORGE B ET AL) 9 November 1965 (1965-11-09)	1	
	* the whole document * -----		
			TECHNICAL FIELDS SEARCHED (IPC)
			A61H
The present search report has been drawn up for all claims			
Place of search Munich		Date of completion of the search 26 February 2010	Examiner Squeri, Michele
CATEGORY OF CITED DOCUMENTS		T : theory or principle underlying the invention E : earlier patent document, but published on, or after the filing date D : document cited in the application L : document cited for other reasons & : member of the same patent family, corresponding document	
X : particularly relevant if taken alone Y : particularly relevant if combined with another document of the same category A : technological background O : non-written disclosure P : intermediate document			

1
EPO FORM 1503 03 82 (P04C01)

**ANNEX TO THE EUROPEAN SEARCH REPORT
ON EUROPEAN PATENT APPLICATION NO.**

EP 09 17 1515

This annex lists the patent family members relating to the patent documents cited in the above-mentioned European search report. The members are as contained in the European Patent Office EDP file on
The European Patent Office is in no way liable for these particulars which are merely given for the purpose of information.

26-02-2010

Patent document cited in search report	Publication date	Patent family member(s)	Publication date	
WO 8909040	A1	05-10-1989	AU 3298989 A DE 3810477 C1	16-10-1989 19-10-1989

US 2002074457	A1	20-06-2002	NONE	

US 2193154	A	12-03-1940	NONE	

US 3216423	A	09-11-1965	NONE	

EPO FORM P0459

For more details about this annex : see Official Journal of the European Patent Office, No. 12/82