



(12) **EUROPEAN PATENT APPLICATION**

(43) Date of publication:
13.04.2011 Bulletin 2011/15

(51) Int Cl.:
E21B 47/00 (2006.01)

(21) Application number: **09172263.7**

(22) Date of filing: **05.10.2009**

(84) Designated Contracting States:
AT BE BG CH CY CZ DE DK EE ES FI FR GB GR HR HU IE IS IT LI LT LU LV MC MK MT NL NO PL PT RO SE SI SK SM TR
 Designated Extension States:
AL BA RS

(72) Inventor: **Hallundbaek, Jørgen**
DK-3230 Græsted (DK)

(74) Representative: **Hoffmann, Claus**
Hoffmann Dragsted A/S
Rådhuspladsen 16
1550 Copenhagen V (DK)

(71) Applicant: **Welltec A/S**
3450 Allerød (DK)

(54) **System for inspecting a casing**

(57) The present invention relates to a system for inspecting a casing, such as a tubing, tubular, pipe, or liner downhole. The casing is connected to a wellhead partly arranged above a surface of a ground or on the seabed and the wellhead is adapted to seal off an interior part of the casing. The system comprises an inspection

device adapted to inspect the wellhead and/or an upper part of the casing and the inspection device comprises at least one transmitter unit and at least one detector unit. Moreover, the system comprises lowering means for lowering either the transmitter unit or the detector unit down through the wellhead into the interior part of the casing.

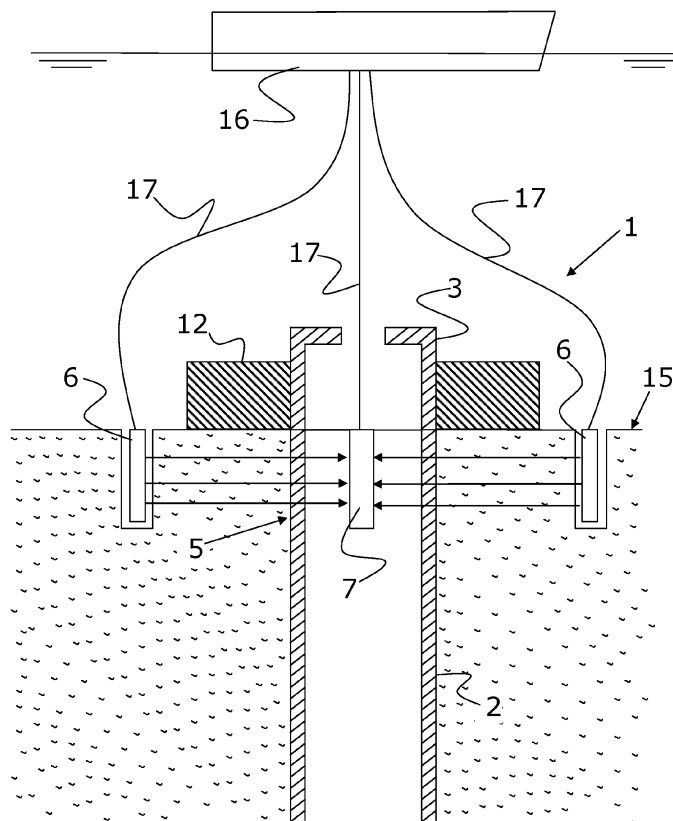

Fig. 1

DescriptionField of the Invention

[0001] The present invention relates to a system for inspecting a casing, such as a tubing, tubular, pipe, or liner downhole. The casing is connected with a wellhead arranged partly above a surface of a ground or on a seabed, which wellhead is adapted to seal off an interior part of the casing. The system comprises an inspection device adapted to inspect the wellhead and/or a part of the casing.

Background Art

[0002] In a subterranean well, the wellhead may be surrounded by a foundation and the wellhead and the foundation may unintentionally be displaced in relation to each other. In some cases, the ground around the wellbore may not be stable enough to withstand the load of the foundation, thus causing the foundation to sink slightly into the ground or tilt slightly. In addition, stress on the wellhead may affect the joint between the wellhead and the casing as well as the upper part of the casing, which may cause the casing to crack and thus become weakened.

[0003] This is especially relevant in regard to subsea wells, as the seabed often provides an insecure ground for support of a foundation or equipment.

[0004] Loads on the wellhead or foundation may moreover be enhanced when equipment is mounted on the wellhead or is supported on the foundation surrounding the wellhead, e.g. if a subsea well intervention module is mounted onto the wellhead in order to carry out an operation.

[0005] When the foundation surrounding the wellhead has been displaced placing inadvertent stress on the wellhead and thus the casing, or when a weak seabed around the wellbore increases the risk of displacement, the additional stress provided by the load of the equipment may cause the foundation and/or the wellhead to tilt even further, creating even further strain on the wellhead and thus also on the joint between the wellhead and the casing as well as the upper part of the casing. As a consequence, large cracks may occur in the casing causing it to leak.

[0006] Moreover, the casing itself may be displaced or bent making access through the casing difficult. The risk of this is increased if the material of the casing has been weakened as well.

[0007] There is thus a need to be able to see whether the material of the wellhead and/or the upper part of the casing has been weakened, whether there are cracks in the casing, and whether part of the casing has been displaced or bent.

Summary of the Invention

[0008] It is an object of the present invention to wholly or partly overcome the above disadvantages and drawbacks of the prior art. More specifically, it is an object to provide an improved system for inspecting a casing such as a tubing, tubular, pipe, or liner downhole, by means of which it is possible to check for weaknesses in the material of the casing and for possible cracks or bends in the casing.

[0009] The above objects, together with numerous other objects, advantages, and features, which will become evident from the below description, are accomplished by a solution in accordance with the present invention by a system for inspecting a casing, such as a tubing, tubular, pipe, or liner downhole, which casing is connected with a wellhead arranged partly above a surface of a ground or on a seabed and which wellhead again is adapted to seal off an interior part of the casing, the system comprising:

- an inspection device adapted to inspect the wellhead and/or an upper part of the casing, wherein the inspection device comprises:
- at least one transmitter unit, and
- at least one detector unit, and
- a lowering means for lowering either the transmitter unit or the detector unit down through the wellhead into the interior part of the casing.

[0010] Such a system makes it possible to check for weaknesses in the material of the casing and for possible cracks or bends in the casing. Moreover, the inspection process can be carried out before placing heavy loads on or around the wellhead, and stress on the wellhead is thus avoided. The entire inspection process takes place before mounting any equipment either directly or indirectly on the wellhead, also serving to avoid inadvertent stress on the wellhead.

[0011] Furthermore, if cracks or weaknesses are observed in the casing wall, the well may very often be too insecure to produce from, as a consequence of which it has to be closed and replaced by a new well. In addition, to have a well in operation with a casing or a wellhead which has cracks or is weakened in material may have severe environmental consequences, since these cracks or weaknesses may cause the well to leak, allowing fluid from the interior of the casing to escape into the environment. This may also be avoided by the system according to the present invention.

[0012] By a casing is meant all kinds of pipes, tubings, tubulars, liners, strings, etc. used downhole in relation to oil or natural gas production.

[0013] In one embodiment, the detector unit may be arranged inside the wellhead or the casing and the transmitter unit may be arranged outside the wellhead or the casing, or vice versa.

[0014] The detector unit may be an image recording

device or be connected to an image recording device in order to detect any irregularity of the wellhead or the casing.

[0015] The transmitter unit may be arranged subterraneanly at a distance from the casing.

[0016] Thus, the transmitter unit may emit radiation below ground level, making it possible to align the transmitter unit with the detector unit vertically. When the transmitter unit and the detector unit are placed at approximately the same vertical level, it is possible to isolate the exposed area of the casing - i.e. the upper part of the casing just below ground level - for inspection for cracks and weaknesses in the material.

[0017] Three or more transmitter units may be arranged around the casing with predetermined distances between them and with predetermined distances from the casing.

[0018] When placing a minimum of three transmitter units with a distance between them around the casing, it is possible to cover the entire circular form of the casing and thus to inspect the entire periphery of the casing by rotating the detector unit.

[0019] In one embodiment of the system, the lowering means may comprise rotation means enabling either the transmitter unit or the detector unit to be rotated within the wellhead and/or the casing. Alternatively, the transmitter unit or detector unit itself may comprise rotation means. Preferably, it is the detector unit which is lowered into the casing and which is rotated.

[0020] In this way, the entire periphery of the casing may be inspected in a simple manner, simply by rotating either the transmitter unit or the detector unit

[0021] In addition, the transmitter unit and detector unit of the inspection device may comprise radiographic means.

[0022] When the inspection device has radiographic means, inspection of the material of the casing may be performed in a simple and non-destructive manner, which again provides a simple and reliable method for testing the state of the wellhead and/or the upper part of the casing.

[0023] In one embodiment, the transmitter unit may be a source of electromagnetic radiation and the detector unit may be a radiation detector.

[0024] Moreover, the electromagnetic radiation may lie within an X-ray spectrum or a gamma ray spectrum.

[0025] In a further embodiment, the detector unit may be connected to signal processing and displaying equipment and signals received from the detector unit may be processed to cross-sectional radiographic images of the wellhead and/or the upper part of the casing.

[0026] Thus, an operator may monitor the state of the wellhead and casing in order to identify possible cracks and/or weaknesses.

[0027] In yet a further embodiment, the detector unit may be a photographic plate or a photostimulable phosphor plate.

[0028] In other embodiments of the system, the trans-

mitter unit and detector unit of the inspection device may comprise acoustic means, thus providing alternative ways of inspecting the material of the casing in a way which is simple, non-destructive, as well as reliable.

5 **[0029]** The system may be adapted to operate subsea.

[0030] Especially when operating subsea, the ground around the well bore may often be unstable, and equipment resting on the seabed may thus often be displaced in relation to the wellhead and the casing.

10 **[0031]** In one embodiment, a wireline may moreover be connected to the transmitter unit and/or the detector unit.

[0032] Using wireline makes it easier to control the different units. Moreover, cables may be used to control units from a distance and data and/or signals may be transmitted by wireline. In addition, wireline may be used to raise or lower the units.

15 **[0033]** When using signal processing and displaying equipment, a storage device may be connected to this equipment.

[0034] It is thus possible to save the images for study at a later time, or for use as documentation.

[0035] In addition, the invention relates to a method for inspecting a casing, such as a tubing, tubular, pipe, or liner downhole, which casing is connected with a wellhead arranged partly above a surface of a ground or on a seabed and which wellhead again is adapted to seal off an interior part of the casing, the method comprising the steps of:

- 20
- 25
- 30
- positioning a transmitter unit or detector unit outside the wellhead and the casing,
 - providing access to the interior of the wellhead,
 - lowering a transmitter unit or detector unit down through the wellhead into an interior part of the upper part of the casing,
 - aligning the transmitter unit or detector unit placed outside the wellhead and casing with the transmitter unit or detector unit placed inside the wellhead and casing, and
 - transmitting a ray, radiation, or a signal from the transmitter unit to the detector unit through the wellhead and casing in order to inspect an area of the wellhead or casing through which the ray, radiation, or signal passes.
- 35
- 40
- 45

[0036] In one embodiment of the method, at least one hole may be provided in the subsoil around the casing and a transmitter unit may be arranged in the hole.

50 **[0037]** In another embodiment, at least one transmitter unit may be inserted into the subsoil.

[0038] In addition, the unit placed inside the wellhead and casing may be rotated.

55 Brief Description of the Drawings

[0039] The invention and its many advantages will be described in more detail below with reference to the ac-

companying schematic drawings, which for the purpose of illustration show some non-limiting embodiments and in which

Fig. 1 shows a system according to the present invention for inspecting a casing inserted in a wellbore subsea,

Fig. 2 shows a horizontal cross-section of another embodiment of the system where three transmitter units are arranged around the casing with predetermined distances between them and with predetermined distances from the casing,

Fig. 3 shows another system according to the present invention for inspecting a casing inserted in a wellbore,

Fig. 4 schematically shows a signal processing and displaying equipment according to the invention, and

Figs. 5 and 6 show different examples of a casing to be inspected.

[0040] All the figures are highly schematic and not necessarily to scale, and they show only those parts which are necessary in order to elucidate the invention, other parts being omitted or merely suggested.

Detailed description of the invention

[0041] In Fig. 1, a system 1 for inspecting a casing 2 inserted in a wellbore subsea is shown. The casing 2 is connected to a wellhead 3 partly arranged on the seabed 15 and surrounded by a foundation 12. The system also comprises an inspection device.

[0042] The casing 2 often consists of steel tubing having a wall thickness and a mainly circular cross-sectional form.

[0043] In this case, the inspection device consists of a detector unit 7 placed within the upper part 5 of the casing 2 - which upper part of the casing, however, lies below the seabed 15 - and a number of transmitter units 6 arranged in the seabed 15 around the foundation 12 with predetermined distances between them and with predetermined distances from the casing. Both the detector unit 7 and the transmitter units 6 are connected to a vessel 16 on the surface of the sea via wirelines 17.

[0044] The number of both detector units 7 and transmitter units 6 may vary. Thus, in another embodiment, it is possible to have more than one detector unit 7 and only one transmitter unit 6. Also, it may be that it is a transmitter unit 6 that is placed within the upper part 5 of the casing instead of a detector unit 7. However, the solution where it is the detector unit 7 that is placed inside the upper part 5 of the casing is preferred at present.

[0045] In Fig. 1, the detector unit 7 and the transmitter units 6 are connected to the vessel 16 on the surface via

wirelines 17; however, other forms of lowering means may be used instead.

[0046] In Fig. 2, an inspection device 4 consisting of one detector unit 7 and three transmitter units 6 is shown. The detector unit 7 is placed within the upper, subterranean part 5 of the casing and the three transmitter units 6 are arranged around the casing 2 with predetermined distances between them and with predetermined distances from the casing. Like in Fig. 1, the casing 2 is surrounded by a foundation 12.

[0047] In the embodiment shown in Fig. 2, the transmitter units 6 may be sources of electromagnetic radiation and the detector unit 7 may be a radiation detector. The transmitter units 6 emit radiation (indicated by the dotted lines) which is detected by the detector unit 7. This makes it possible to align the transmitter units 6 with the detector unit 7 vertically. When the transmitter units 6 and the detector unit 7 are placed at approximately the same vertical level, the exposed area of the casing - i.e. the upper part 5 of the casing just below ground level - is isolated, making it possible to inspect the area for cracks and weaknesses in the material.

[0048] Placing a minimum of three transmitter units 6 with a distance between them around the casing 2 makes it possible to cover the entire circular form of the casing and thus to inspect the entire periphery of the casing by rotating the detector unit 4 within the upper, subterranean part 5 of the casing.

[0049] As mentioned above, the system 1, consisting of the transmitter 6 and detector units 7 of the inspection device, may use electromagnetic radiation for inspecting the casing 2 and/or the wellhead 3. Advantageously, the electromagnetic radiation may lie within an X-ray spectrum or a gamma ray spectrum.

[0050] In other embodiments of the system 1 according to the invention, the transmitter 6 and detector units 7 of the inspection device 4 may use acoustic for inspecting the casing 2 and/or the wellhead 3.

[0051] Even though the present invention has mainly been described in relation to a subsea well, the invention might as well be used in connection with other wells, e.g. as shown in Fig. 3.

[0052] In Fig. 3, a vehicle 20 comprises lowering means 8 in the form of a crane and a winch. The lowering means 8 is connected to the detector unit 7, which is lowered into the casing 2 through the wellhead 3. The transmitter units 6 are placed in holes below a surface of the ground 18 and transmit rays, radiation, or signals (indicated by the arrows 21) through the ground and through the wall of the casing 2 to the detector unit 7. The detector unit 7 is connected to signal processing and displaying equipment (not shown). When the system 1 uses e.g. electromagnetic radiation, the signals received from the detector unit 7 are processed to cross-sectional radiographic images of the wellhead 3 and/or the upper part 5 of the casing, which may be used to inspect the casing and/or wellhead for any irregularities that might influence the strength of the casing. This is shown sche-

matically in Fig. 4. In this embodiment, the signal processing and displaying equipment 25 comprises a signal processing unit 26, a storage device 27, and a displaying device 28.

[0053] Figs. 5 and 6 show two examples of a casing 2 with irregularities.

[0054] In Fig. 5, two cracks 30 have appeared in the wall of the casing 2. The strength of the casing 2 in this area will thus have been limited and, as a consequence that the casing may collapse and/or leak may occur in this area. Such cracks 30 can be discovered using the system 1 according to the present invention.

[0055] In the example of Fig. 6, the casing has been bent. Here, the casing 2 is connected to a foundation 12, which has tilted in relation to its original position, causing the casing 2 to bend in the area 31. In this example, the casing 2 is very difficult to use since no tool or equipment can be brought to operate properly inside the casing, but will be hindered by the bend. This irregularity may also be discovered using the system 1 according to the present invention.

[0056] Although the invention has been described in the above in connection with preferred embodiments of the invention, it will be evident for a person skilled in the art that several modifications are conceivable without departing from the invention as defined by the following claims.

Claims

1. A system (1) for inspecting a casing (2), such as a tubing, tubular, pipe, or liner downhole, which casing (2) is connected with a wellhead (3) arranged partly above a surface of a ground or on a seabed and which wellhead again is adapted to seal off an interior part of the casing (2), the system (1) comprising:
 - an inspection device (4) adapted to inspect the wellhead and/or an upper part (5) of the casing (2), wherein the inspection device (4) comprises:
 - at least one transmitter unit (6), and
 - at least one detector unit (7), and
 - a lowering means (8) for lowering either the transmitter unit or the detector unit down through the wellhead into the interior part of the casing (2).
2. A system according to claim 1, wherein the detector unit (7) is arranged inside the wellhead (3) or the casing (2) and the transmitter unit (6) is arranged outside the wellhead or the casing, or vice versa.
3. A system according to claim 1 or 2, wherein the detector unit (7) is an image recording device or connected to an image recording device in order to detect any irregularity of the wellhead or the casing.
4. A system according to any of the preceding claims, wherein the transmitter unit (6) is arranged subterraneanly at a distance from the casing (2).
5. A system according to claim 1, wherein three or more transmitter units (6) are arranged spaced apart and at a distance from the casing.
6. A system according to claim 1, wherein the lowering means (8) comprises rotation means enabling either the transmitter unit (6) or the detector unit (7) to be rotated within the wellhead and/or the casing, the transmitter unit (6) or the detector unit (7) itself alternatively comprising rotation means.
7. A system according to claim 1 or 2, wherein the transmitter unit (6) and detector unit (7) of the inspection device (4) comprises radiographic means.
8. A system according to claim 3, wherein the transmitter unit (6) is a source of electromagnetic radiation and the detector unit (7) is a radiation detector.
9. A system according to claim 4, wherein the electromagnetic radiation lies within an X-ray spectrum or a gamma ray spectrum.
10. A system according to any of the preceding claims, wherein the detector unit (7) is connected to signal processing and displaying equipment.
11. A system according to claim 7, wherein signals received from the detector unit (7) are processed to cross-sectional radiographic images of the wellhead and/or the upper part of the casing.
12. A system according to any of the preceding claims, wherein the detector unit (7) is a photographic plate or a photostimulable phosphor plate.
13. A system according to claim 1, wherein the transmitter unit (6) and the detector unit (7) of the inspection device comprise acoustic means.
14. A system according to any of the preceding claims, wherein the system is adapted to operate subsea.
15. A method for inspecting a casing (2), such as a tubing, tubular, pipe, or liner downhole, which casing (2) is connected with a wellhead (3) arranged partly above a surface of a ground or on a seabed and which wellhead (3) again is adapted to seal off an interior part of the casing (2), the method comprising the steps of:
 - positioning a transmitter unit (6) or detector unit (7) outside the wellhead (3) and casing (2),
 - providing access to the interior of the wellhead

- (3),
- lowering a transmitter unit (6) or detector unit (7) down through the wellhead (3) into an interior part of the upper part of the casing (2),
 - aligning the transmitter unit (6) or detector unit (7) placed outside the wellhead and casing with the transmitter unit (6) or detector unit (7) placed inside the wellhead and casing, and
 - transmitting a ray, radiation, or a signal from the transmitter unit (6) to the detector unit (7) through the wellhead and casing in order to inspect an area of the wellhead or casing through which the ray, radiation, or signal passes.

15

20

25

30

35

40

45

50

55

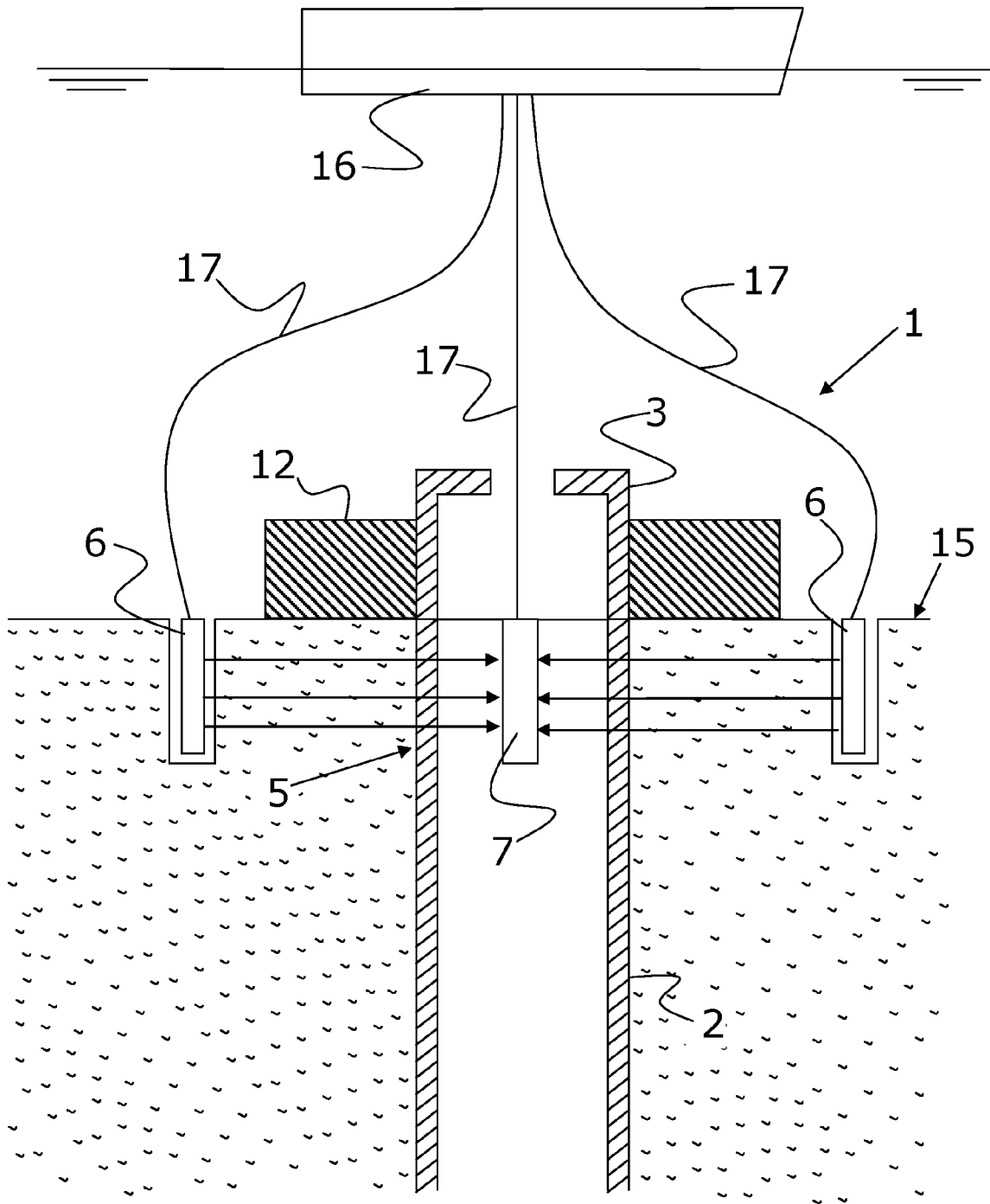
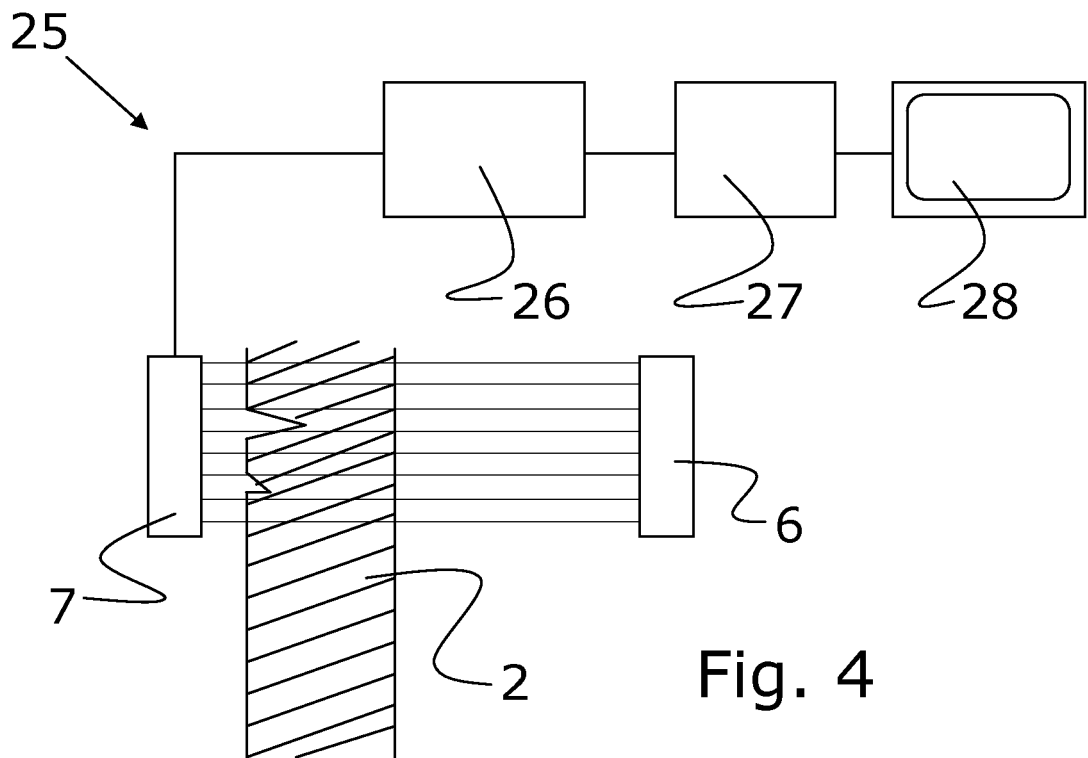
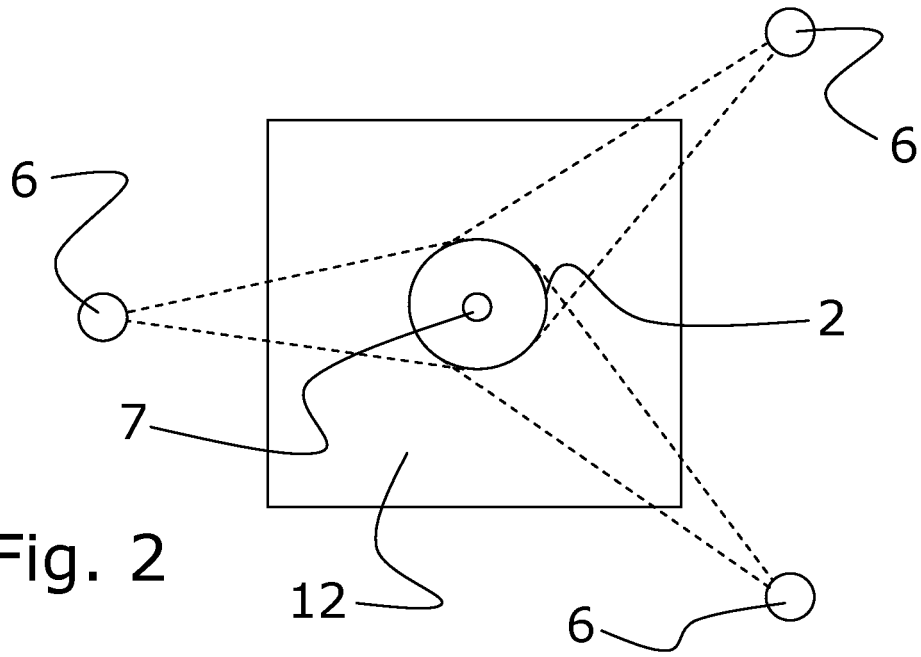
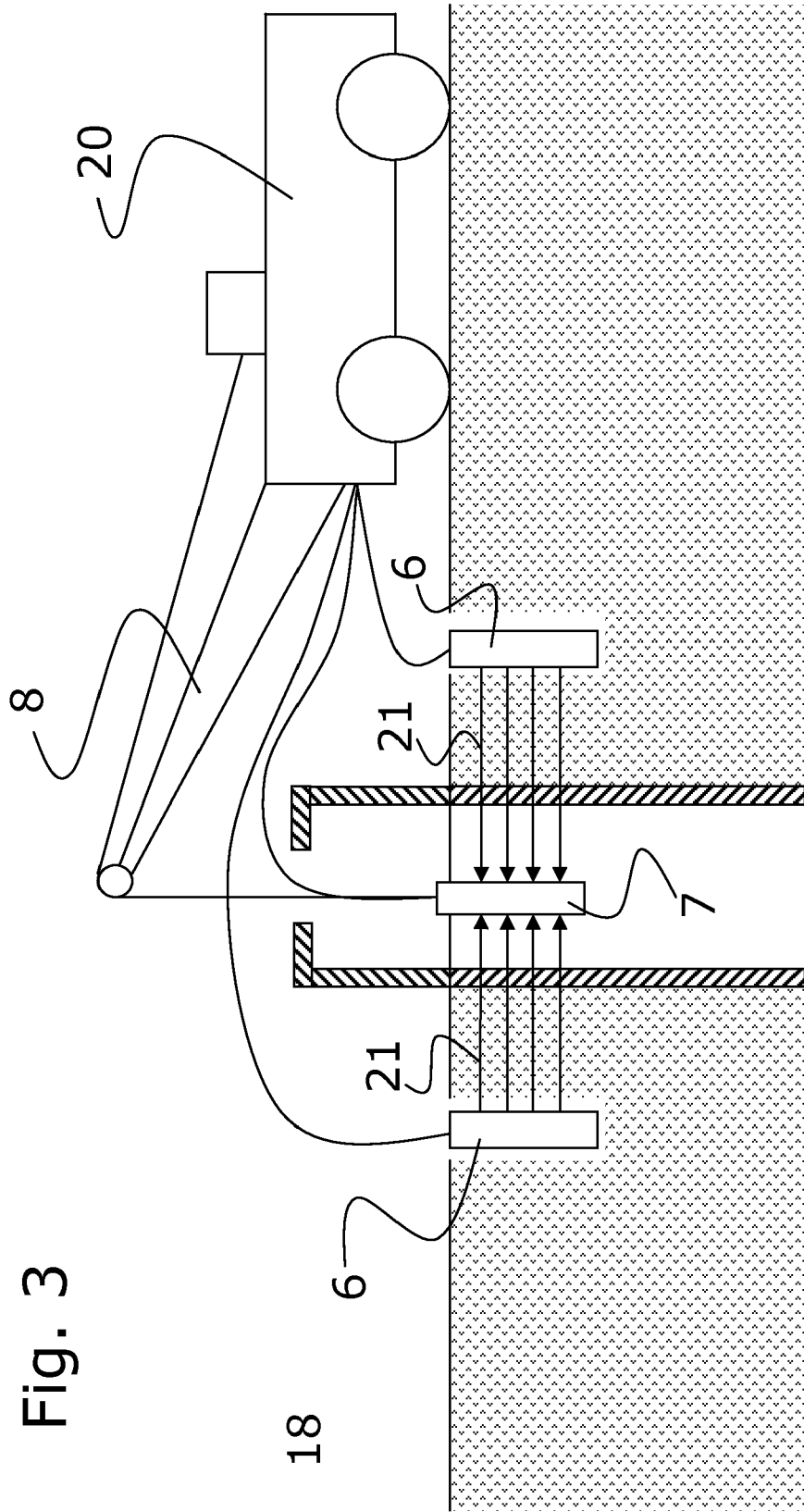

Fig. 1





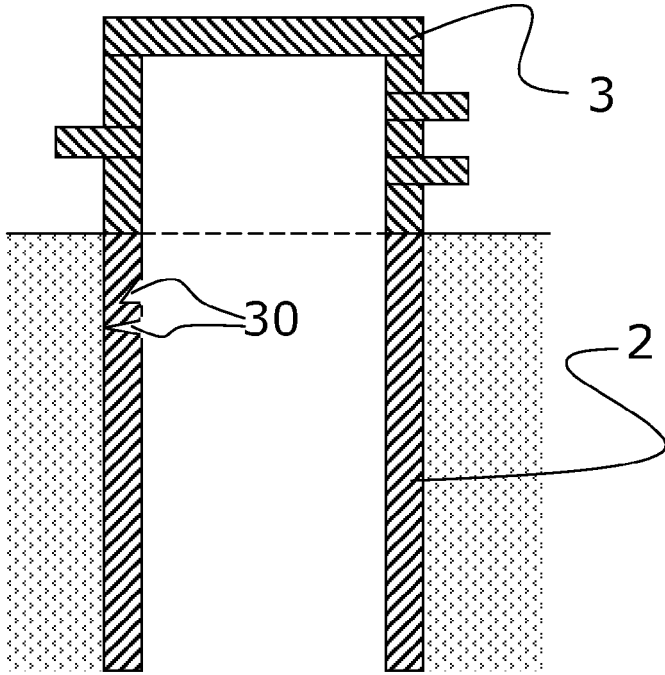

Fig. 5

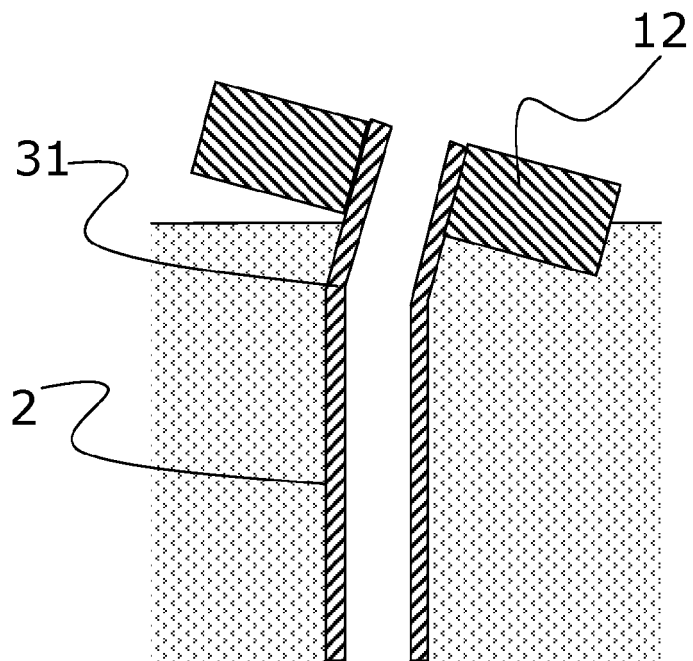

Fig. 6



EUROPEAN SEARCH REPORT

 Application Number
 EP 09 17 2263

DOCUMENTS CONSIDERED TO BE RELEVANT			
Category	Citation of document with indication, where appropriate, of relevant passages	Relevant to claim	CLASSIFICATION OF THE APPLICATION (IPC)
X	US 2001/027865 A1 (WESTER RANDY J [US]) 11 October 2001 (2001-10-11)	1-5,7-15	INV. E21B47/00
Y	* paragraphs [0038] - [0039], [0045] - [0047] *	6	
X	US 5 397 985 A (KENNEDY W DAVID [US]) 14 March 1995 (1995-03-14)	1-2	
Y	* column 2, line 59 - column 3, line 47; figure 1 *	6	
X	US 2007/211572 A1 (REIDERMAN ARCADY [US] ET AL) 13 September 2007 (2007-09-13)	1	
Y	* paragraph [0042] - paragraph [0047]; figure 3 *	1	
X	US 3 221 548 A (WILSON JOHN C) 7 December 1965 (1965-12-07)	1	TECHNICAL FIELDS SEARCHED (IPC) E21B
Y	* column 3, line 3 - line 39; figure 1 *	1	
X	US 4 701 892 A (ANDERSON LEO J [US]) 20 October 1987 (1987-10-20)	1	
Y	* column 1, line 20 - line 55; figures 1,3 *	1	
A	US 3 489 219 A (HIGGINS ROBERT E) 13 January 1970 (1970-01-13)	1-15	
Y	* column 2, line 35 - column 3, line 10; figure 1 *		
The present search report has been drawn up for all claims			
Place of search Munich		Date of completion of the search 1 February 2010	Examiner Strømme, Henrik
CATEGORY OF CITED DOCUMENTS		T : theory or principle underlying the invention E : earlier patent document, but published on, or after the filing date D : document cited in the application L : document cited for other reasons	
X : particularly relevant if taken alone Y : particularly relevant if combined with another document of the same category A : technological background O : non-written disclosure P : intermediate document		& : member of the same patent family, corresponding document	

 1
 EPO FORM 1503 03.02 (P04C01)

**ANNEX TO THE EUROPEAN SEARCH REPORT
ON EUROPEAN PATENT APPLICATION NO.**

EP 09 17 2263

This annex lists the patent family members relating to the patent documents cited in the above-mentioned European search report. The members are as contained in the European Patent Office EDP file on
The European Patent Office is in no way liable for these particulars which are merely given for the purpose of information.

01-02-2010

Patent document cited in search report	Publication date	Patent family member(s)	Publication date
US 2001027865 A1	11-10-2001	NONE	
US 5397985 A	14-03-1995	NONE	
US 2007211572 A1	13-09-2007	WO 2008141331 A1	20-11-2008
US 3221548 A	07-12-1965	NONE	
US 4701892 A	20-10-1987	CA 1268850 A1	08-05-1990
US 3489219 A	13-01-1970	GB 1163786 A	10-09-1969

EPO FORM P0459

For more details about this annex : see Official Journal of the European Patent Office, No. 12/82