

(19)



(11)

EP 2 314 752 B1

(12)

EUROPEAN PATENT SPECIFICATION

(45) Date of publication and mention
of the grant of the patent:
17.04.2013 Bulletin 2013/16

(51) Int Cl.:
D06F 39/08 (2006.01)

(21) Application number: **10181887.0**

(22) Date of filing: **12.12.2006**

(54) **Anti-flooding safety device for a household appliance**

Überlaufschutzvorrichtung für Haushaltsgeräte, besonders für Waschgeräte

Dispositif de sécurité anti-écoulement pour appareils électroménagers, notamment pour machines à laver

(84) Designated Contracting States:
**AT BE BG CH CY CZ DE DK EE ES FI FR GB GR
HU IE IS IT LI LT LU LV MC NL PL PT RO SE SI
SK TR**

(30) Priority: **15.12.2005 IT TO20050876**

(43) Date of publication of application:
27.04.2011 Bulletin 2011/17

(62) Document number(s) of the earlier application(s) in
accordance with Art. 76 EPC:
**08165774.4 / 2 014 818
06125957.8 / 1 798 326**

(73) Proprietor: **Eltek S.p.A.**
15033 Casale Monferrato (AL) (IT)

(72) Inventor: **Bianchi, Luciano**
15030 Rosignano Monferrato (Alessandria) (IT)

(74) Representative: **Gallarotti, Franco
Buzzi, Notaro & Antonielli d'Oulx
Via Maria Vittoria, 18
10123 Torino (IT)**

(56) References cited:
**DE-A1- 3 618 258 DE-A1- 10 126 104
FR-A1- 2 742 514 US-A1- 3 299 417
US-A1- 5 983 950**

EP 2 314 752 B1

Note: Within nine months of the publication of the mention of the grant of the European patent in the European Patent Bulletin, any person may give notice to the European Patent Office of opposition to that patent, in accordance with the Implementing Regulations. Notice of opposition shall not be deemed to have been filed until the opposition fee has been paid. (Art. 99(1) European Patent Convention).

Description

[0001] The present invention relates to an anti-flooding safety device for electrical household appliances, in particular for washing appliances. The invention has been developed with particular reference to devices of the type referred to above designed to be operatively set between a source of supply of a liquid and an electrical household appliance.

[0002] The use of an electrical household appliance supplied with a liquid, or in which a liquid flows, entails in general the risk of flooding of the premises where the appliance is installed on account of possible accidental leaks. Said leaks may, for example, be due to malfunctioning of devices internal to the electrical household appliance or to failure of the pipes for delivery or discharge of the liquid.

[0003] For the above purpose, anti-flooding devices are known which are able to provide a practically continuous control of the presence of possible leaks. Said devices generally envisage at least one valve, operative upstream of a water-intake pipe, and sensor means, arranged in a water-collecting tray, positioned in the electrical household appliance. In the event of malfunctioning of the internal devices of the electrical household appliance, the leakage water reaches said collecting tray, with the consequent intervention of the sensor means, provided for controlling closing of the aforesaid valve.

[0004] The valves used for the purpose are typically actuated in an electrical, mechanical, or pneumatic way; the sensor means are typically of an electromechanical type (for example, based upon the use of a float and a microswitch) or else basically of a mechanical type (for example, based upon the use of an anhydrous sponge, designed to expand when it comes into contact with a liquid).

[0005] Some safety devices are equipped also with an external pipe, which surrounds the water-intake pipe. In the case of failure of the latter, the external pipe enables confluence in the aforesaid collecting tray of the leakage liquid so as to cause closing of the safety valve (see, for example, FR-A-2 742 514). In other solutions, the gap defined between the two pipes is designed to withhold the leakage water directly, instead of conveying it into a collecting tray. In a first type of these two-pipe devices, the presence of water inside the gap causes an increase of volume of an anhydrous sponge, which controls accordingly closing of the valve of the device (see, for example, IT-B-1 207 365). Other two-pipe devices are instead simply prearranged for withholding the water and visually signalling the presence thereof within the gap in order to inform the user regarding the need for an intervention of assistance (see, for example, DE-A-10 12 6104).

[0006] In known devices, the water-intake pipe, i.e., the internal pipe, is typically a pipe with smooth surfaces, made of polyvinyl chloride (PVC), with other possible materials or reinforcement fibres. The external pipe is typi-

cally a corrugated pipe, usually made of polypropylene (PP). One of the major problems that are encountered in the safety devices according to the known art is represented by the poor flexibility of the internal pipe made of PVC, which, in the case of narrow-radius curvature of the external pipe, tends to form kinks or squeeze on itself, determining a drastic reduction in the section of passage for the liquid. A kink or local squeezing can determine excessive pressures in the water-intake pipe, that cannot be directly detected by the user and are potentially harmful both for the integrity of the device and for proper operation of the electrical household appliance. Traditional pipes made of PVC are moreover relatively costly and heavy.

[0007] The main purpose of the present invention is to overcome the aforesaid drawbacks. This and other purposes still are achieved, according to the present invention, by an anti-flooding safety device and by a corresponding preferred method of production presenting the characteristics of the annexed claims, which form an integral part of the descriptive content of the present patent application.

[0008] Further purposes, characteristics, and advantages of the present invention will emerge clearly from the ensuing detailed description and from the annexed plate of drawings, which is provided purely by way of explanatory and non-limiting example and in which:

- Figure 1 is a schematic, partially cross-sectional view of an anti-flooding safety device according to the invention;
- Figure 2 is a schematic, partially cross-sectional view of a water-intake pipe forming part of the device of Figure 1; and
- Figures 3-5 are schematic cross-sectional views of moulding apparatus that can be used for the purposes of the production of part of the pipe of Figure 2, in three different operating conditions.

[0009] Designated as a whole by 1 in Figure 1 is an anti-flooding safety device for electrical household appliances according to the invention. The device 1, which is in particular indicated for use in combination with washing appliances, such as dish-washers, comprises a connector body 2, a water-intake pipe 20, or internal pipe, and an external pipe 30.

[0010] The connector body, or valve body, is preferably made of plastic or thermoplastic material and defines within it a conduit 3 for passage of water. The body 2 is configured so that the conduit 3 has an inlet 3a and an outlet 3b, between which there extends a part of conduit in which means for shutting-off the water are operative. In the example shown, said means comprise a solenoid valve 4.

[0011] The solenoid valve 4 is of a type and presents a form of operation in themselves known (see, for example, FR-A-2 742 514). Herein it will suffice to point out that the solenoid valve 4 has an electromagnet 5

equipped with supply terminals, one of which is designated by 6. The solenoid valve 4 comprises then an open/close element 7, actuated by means of an armature or movable core 8, which is housed in a respective body 9. The latter has a threaded part, screwed in an open seat equipped with internal screw, which is made in the body 2 and opens onto the conduit 3. The electromagnet 5, which is preferably enclosed in a protective coating 10 obtained by overmoulding of thermoplastic material, is mounted on the body 9. When the electromagnet 5 is not supplied, the open/close element 7 - through the movable core 8 - is held by a spring in a resting position, which does not allow passage of water from the inlet 3a to the outlet 3b. In the case of supply of the electromagnet 5, instead, the core 8 is induced to displace to overcome the force of contrast of the aforesaid spring: in this case, the open/close element 7 is designed to assume a position of opening, which enables passage of the flow of water through the conduit 3.

[0012] In the upper area of the valve body 2, in which the inlet 3a is defined, an external ring nut 11 is mounted for coupling of the device 1 to a source of supply of the water, such as a tap (not represented). Mounted in the upper part of the conduit 3, upstream of the solenoid valve 4 are a filter 12 and a flow regulator 13. The lower area of the valve body 2 has a substantially cylindrical coupling part 2a, defined in which is the outlet 3b. Defined on the outer surface of said part 2a are teeth or annular retention reliefs 2b.

[0013] According to the main aspect of the invention, the internal pipe 20 is a corrugated pipe, i.e., one with undulated wall. In practice, the outer surface of the pipe 20 (but also the inner one) is defined by a series of reliefs and recesses, preferably annular and parallel to one another and arranged according to a regular series. Said reliefs and recesses could, on the other hand, have a spiral pattern along the pipe 20.

[0014] In the embodiment represented in Figures 1 and 2, the wall or the cross section of the pipe 20 has a pattern with square profile, i.e., with reliefs and recesses defined by contiguous stretches of wall that are substantially mutually orthogonal (a sort of "square wave"). Alternatively, the aforesaid reliefs and recesses could have a substantially trapezoidal profile, i.e., at least in part delimited by slightly inclined or divergent stretches of wall. The pipe 20 could also have a pattern similar to what is shown for the external pipe 30, with substantially rounded external profile, i.e., with reliefs and recesses radiused by stretches of wall that are semicircular or shaped like the arc of a circumference (a sort of "sinusoidal wave").

[0015] According to the invention, the internal corrugated pipe 20 is made of polypropylene. A pipe of this sort has characteristics of flexibility - understood as capacity for deformation without squeezing or kinking or local curvatures - decidedly better than the traditional water-intake pipes made of PVC. In contrast, a corrugated pipe of the type referred to above presents characteristics of elasticity that are inferior to those of pipes made of

PVC. For said reason, according to a preferred characteristic of the invention, at least one end portion of the internal pipe 20 is coupled to a first end portion 21 a of a respective tubular connection element, designated as a whole by 21. The tubular element 21 has, in its portion 21a, an axial stretch of inner surface structured for engagement with an axial stretch of the outer surface of the pipe 20. The tubular element 21 has then a second end portion 21b designed to be engaged or fitted on the coupling part 2a of the body 2. As may be seen also in Figure 2, the inner surface of the element 21 defines - in the portion 21a - a regular series of reliefs and recesses, where the surface reliefs of the element 21 are engaged in the recesses of the outer surface of the pipe 20, whilst the reliefs of the outer surface of the pipe 20 are engaged in the surface recesses of the tubular element 21. Thanks to the aforesaid characteristics, the mechanical coupling and the hydraulic seal between the pipe 20 and the tubular element 21 are excellent.

[0016] In the preferred embodiment of the invention, the tubular member 21 is co-moulded with, or overmoulded directly on, the terminal stretch of the pipe 20, so that part of the inner surface of the tubular element 21 and part of the outer surface of the pipe 20 are practically complementary to one another. The pipe 20 and the tubular element 21 can be intimately joined to one another also as a result of an adhesion or bonding of the respective constituent materials, which may be of types compatible for said purpose.

[0017] The second end portion 21b of the tubular element 21 is, as has been said, fitted on the part 2a of the valve body 2, on which the reliefs 2b are provided. On the outside of said portion 21b there is preferably fitted a mechanical clamping component 22, constituted, for example, by a metal clinching bushing, which can be locally deformed by tightening the tubular element 21 on the part 2a of the body 2.

[0018] It is to be pointed out that the presence of the reliefs and of the recesses of the tubular element 21, albeit preferable, is not strictly necessary for the purposes of the implementation of the invention. In other words, also the inner surface of the portion 21 a of the element 21 can be substantially smooth, in which case at least one mechanical element is provided, designed to clamp or grip externally said portion 21 a on the pipe 20. Such a gripping element, preferably of an annular shape, can be of construction conceptually similar to the component 22, or else be constituted by an appropriate stretch or prolongation of said component 22.

[0019] The material constituting the tubular element 21 is preferably an elastic synthetic material, such as an elastomer (for example, Santoprene®) in order to enable an easy fitting of the element itself on the part 2a of the body 2.

[0020] In the non-limiting example represented, the upper end of the pipe 20 is not directly in contact with or fitted on the part 2a of the body 2. For said purpose, the tubular element 21 can present an intermediate portion

between the end portions 21a, 21b, which sets the outlet 3b in fluid communication with the pipe 20. In this way, there is prevented the risk that any curvature of the pipe 20 in the proximity of the part 2a of the valve body 2 will be such as to jeopardize the quality of the hydraulic seal and of the mechanical coupling between the two parts in question.

[0021] Obviously, there is nothing to rule out mounting or fitting the corrugated pipe 20 directly on the part of body 2a, in which case there is preferably provided a suitable external gripping element of the type mentioned above, or else on the end part of the pipe 20 and on the part of body 2a there is overmoulded a material that coats both of them.

[0022] The corrugated external pipe 30 encloses or surrounds at least partially the pipe 20 and has the function of collecting, and/or withholding, and/or conveying the leakage water in the case of failure of the pipe 20, or else in the case of occasional leaks from the body 2 or from the element 21. As may be appreciated, formed between the two pipes 20, 30 is a gap 31, designed to receive the leakage water, in order to withhold it and/or convey it even when under pressure. In the embodiment exemplified in Figure 1, there extends, in the gap 31, an electrical cable 32, the conductors 32a, 32b of which are connected, at respective first ends, to the terminals 7 of the solenoid valve 4. The second ends of the conductors 32a, 32b are equipped with respective terminals 33a, 33b, for connection to the control of the device or the control system of the interlocked electrical household appliance, which preferably comprises sensor means for detecting leakage of water of a type in itself known.

[0023] In other versions of the anti-flooding safety device (not represented), the electrical cable 32 could be connected, instead of to a valve, to other members of the device itself, and in particular to detection means (constituted, for example, by a sensor for detecting the presence of liquid that operates inside the gap 31, or else by a flowmeter that operates along the pipe 20 or upstream thereof, for example associated to the body 2).

[0024] In the embodiment represented, the electromagnet 5 of the valve 4 is coated directly with a protective and insulating coating 40, made of thermoplastic material. The coating 40 coats, at least partially, also the valve body 2, substantially according to the technique described in the aforesaid document FR-A-2 742 514.

[0025] In its lower region, the coating 40 forms a further substantially cylindrical coupling part 41, on the outer surface of which coupling teeth or projections 41a are formed, similar to the ones present on the part 2a of the body 2. In the embodiment illustrated, a portion of the upper end of the external pipe 30 is coupled to the part 41 of the coating 40 via a respective hollow connection element, designated by 42.

[0026] The element 42 fulfils functions of coupling and seal substantially similar to those of the tubular element 21. In said perspective, then, also the connection element 42 has - on the inner surface of one of its first end portions

42a - a series of reliefs and recesses, coupled with the recesses and reliefs defined on the outer surface of the corrugated external pipe 30. A second end portion 42b of the element 42 is instead fitted on the part 41 of the coating 40. Also in this case, there is preferably provided a metal clinching bushing 43, deformable locally for gripping the element 42 on the part 41. The connection element 42 can also be overmoulded on the respective terminal stretch of the external pipe 30 and made of an elastic synthetic material, such as Santoprene®.

[0027] It should be noted that also to the pipe 30 and to the corresponding connection element 42 it is possible to apply the variant embodiments previously mentioned in relation to the pipe 20 and the tubular element 21, as regards the profile of the projections and of the recesses, the smooth conformation of the inner surface of the portion 42a, the provision of an external gripping element for the portion 42a, the latter being configured as a component in itself or else as prolongation of the element 43, and so forth.

[0028] As may be seen in Figure 2, also the lower end of the corrugated internal pipe 20 can be equipped, if need be, with a tubular element 23, of construction similar to the tubular element previously designated by 21. In the same way, also the lower end of the pipe 30 can be provided with an element similar to the element 42 or else to the element 21 or 23.

[0029] As already mentioned, in a preferred embodiment of the invention, the element 21, 23 can be overmoulded directly on the terminal region of the pipe 30 and/or 40. Illustrated schematically in Figures 3-5 is a possible apparatus or mould that can be used for said purpose. The apparatus, designated as a whole by 50, comprises three parts, and in particular a central part or insert 51 and two peripheral half-moulds 52, 53. Each half-mould 52, 53 has a respective impression 52a, 53a (Figure 5), which is to define a respective portion of the external profile of the element 21. The remaining portion of the profile of the element 21 is instead defined in part by the insert 51 and in part directly by a terminal portion of the pipe 20. Formed in the half-mould 52 is a conduit 54, for injection of the moulding or overmoulding material.

[0030] As may be seen in Figure 5, the insert 51 has a cylindrical part 51a having a distal end 51b with reduced cross section or diameter, configured to enable partial penetration in the end of the corrugated pipe 20, in order to provide a seal suitable for preventing the possibility of the overmoulding material penetrating inside the pipe itself during the process of injection. The maximum diameter of the end 51b can be slightly greater than the internal diameter of the pipe 20. For the purposes of the formation of the tubular element 21, the end of the pipe 20 is fitted on the region 51a of the insert 51, with the two half-moulds 52, 53 in the open position, i.e., divaricated (as shown in Figure 5). This is followed by closing of the half-moulds 52, 53, with the apparatus 50, which thus comes to be in the condition that may be seen in Figure 3. In this way, the impressions of the half-moulds 52, 53 delimit, togeth-

er with the insert 51 and the stretch of pipe 20 internal to the apparatus 50, a space 55 designed to receive the material to be injected through the conduit 54.

[0031] Following upon injection, as may be seen in Figure 4, the material fills the aforesaid space 55 completely, thus forming the tubular element 21 directly on the pipe 20. A first inner surface of the portion 21a of the element 21, provided with reliefs and recesses, is determined by the external shape of the pipe 20, whilst a second inner surface of the portion 21b of the element 21, which is substantially smooth, is determined by the cylindrical part 51 a of the insert 51. In this way, at least part of the inner surface of the element 21 assumes a shape that is complementary to the outer surface of the pipe 20. Following upon an appropriate time for cooling/hardening of the injection material, the half-moulds 52, 53 are opened, as may be seen in Figure 5, and the pipe 20 with the element 21 coupled thereto can be slid off the insert 51.

[0032] Obviously, an apparatus conceptually similar to the one illustrated in Figures 3-5 can be used for the purposes of overmoulding the connection element 42 on the corrugated external pipe 30, or else for the purposes of moulding on the corrugated pipe 30 other elements (not shown), preferably made of elastomer. An apparatus conceptually similar to the one illustrated in Figures 3-5 can also be used for the purposes of just moulding a tubular element 21, designed to be mounted at a later date on the corrugated pipe 20, exploiting, for example, the elastic properties of the elastomeric material with which said element is preferably made. In said variant, the apparatus 50 is equipped with an insert 51 having a shape different from the one exemplified, or else is equipped with a further insert, having at least in part the external shape of the corrugated pipe 20, or else having a completely smooth cylindrical surface (according to whether the aim is to provide a tubular element 21 with inner surface having reliefs and recesses or else completely smooth).

[0033] The safety device according to the invention is less expensive to produce than the devices according to the known art, thanks to the replacement of the polyvinyl-chloride reinforced water-intake pipe with a pipe of simpler construction, which requires a reduced amount of material of lower cost and that has lower weight. The fact that both of the pipes of the device according to the invention may be formed with one and the same material, in particular polypropylene, simplifies disposal of the product at the end of its useful life. The elimination of the water-intake pipe made of polyvinyl chloride hence enables important benefits to be obtained also from the ecological standpoint. The use of an internal corrugated pipe prevents any risk of squeezing or local kinks typical of the known art, with evident advantages in terms of reliability and safety of the device. The tubular connection element, when envisaged, simplifies the modalities of mechanical coupling and sealing of the corrugated pipe internal to the valve body of the device.

[0034] The preferred field of application for the inven-

tion is that of anti-flooding safety devices equipped with electrical, or mechanical, or pneumatic shut-off means. In principle, the invention is in any case suitable for use also in relation to anti-flooding safety devices without valve means or that can be associated to independent shut-off means, i.e., of the type with simple visual warning or else of the type provided with only means for detection of an anomalous condition (such as water-leakage sensor means, or else flowmeter means, without necessarily providing a valve). The device according to the invention may be used to advantage in washing appliances, such as washing machines and dish-washers, but is in general applicable also to other types of electrical household appliances connected to a source of supply of liquid (such as, for example, refrigerators equipped with dispensers of beverages or cooled water).

[0035] It is clear that numerous variants are possible for a person skilled in the branch to the device described by way of example, without thereby departing from the scope of the inventive idea, as defined in the attached claims.

[0036] In accordance with a possible variant embodiment, the elements 21 and 42 are made of a single body. The element 21 or 42 can possibly exert a sealing action on both of the pipes 20, 30. The formation of both of the corrugated pipes of the device 1 with one and the same material can enable a more convenient seal between them (for example, if they are both overmoulded with a single material, preferably an elastomer, which is glued or bonded to both of the corrugated pipes 20 and 30 and/or to at least part of the body 2 and/or of its coating 40).

[0037] The elements 21 and 42, or the single body that integrates them, could also be configured as a piece moulded on itself, subsequently fitted on the pipe 20 and/or on the pipe 30. In this perspective, in accordance with a further possible variant, the aforesaid elements can be formed with material designed to shrink after being fitted on the pipe 20 and/or 30, for example following upon a thermal stress (heat-shrinking materials) or following upon cessation of a stress, for example a mechanical or thermal stress (materials with shape-memory effect).

[0038] As has been said, the safety-valve means that equip the device according to the invention can also be pneumatically or else mechanically actuated. In some of these applications, instead of the cable 32, inside the gap 31 there can extend an air conduit (for example, a small flexible conduit) or else a suitable transmission (for example a Bowden cable with corresponding sheath) in order to transmit the pneumatic or else mechanical command from the sensor means provided to the valve means.

[0039] The tubular element 21 could be overmoulded on the pipe 20, and the connection element 42 could be subsequently overmoulded both on a part of the element 21 and on a part of the external pipe 30.

[0040] The device according to the invention can pos-

sibly comprise a plurality of corrugated pipes 20, 30 connected to one another in series, for example via intermediate-connection means. Said solution is envisaged in the case of modular safety devices or ones equipped with extensions, or else of the type in which the valve body is located in a position intermediate between two stretches of corrugated pipe 20, 30.

Claims

1. An anti-flooding safety device (1) for a household appliance, in particular for loading or intake of a liquid into the household appliance, the device (1) comprising a connector body (2, 40), a first flexible pipe (20) and a second flexible pipe (30), wherein in the connector body (2, 40) a conduit (3) is defined in fluid communication with the first pipe (20), the latter being provided for conveying a liquid, and wherein at least one part of the first pipe (20) extends longitudinally inside the second pipe (30) in such a way that between at least part of the two pipes (20, 30) a gap (31) is defined, which is able to convey and/or withhold possible leakage liquid, the two pipes (20, 30) being impermeable to the liquid, said device being **characterized in that** the first pipe (20) is a corrugated pipe and is made of polypropylene.
2. The device according to Claim 1, wherein also the second pipe (30) is a corrugated pipe.
3. The device according to Claim 1, further comprising valve means (4) for shutting off the liquid, where in particular the valve means (4) are mounted on the connector body (2, 40) and are operative in a stretch of the conduit (3) that is intermediate between an inlet (3a) and an outlet (3b) thereof, where in particular extending inside the gap (31) are means (32) for transmitting to the valve means (4) a closing command.
4. The device according to at least one of Claims 1 to 3, further comprising detection means (33a, 33b).
5. The device according to at least one of the preceding claims,
 - comprising at least one electrical wire or cable (32), in particular extending at least in part in said gap (31) and/or at least in part on the outside of the first corrugated pipe (20) and/or between the first corrugated pipe (20) and the second corrugated pipe (30), and/or
 - wherein the conduit (3) of the connector body (2) has an inlet (3a) and an outlet (3b), the connector body (2, 40) being shaped for connection of one of said inlet (3a) and said outlet (3b) to the first corrugated pipe (20), where in particular

the connector body (2, 40) has a coupling part (2a), defined in which is said outlet (3b), on which it is engaged, or fitted on, an end portion of the first corrugated pipe (20),

and/or

- further comprising connection means (21, 22) between the connector body (2) and the first corrugated pipe (20).

6. The device according to Claim 5, wherein at least one end portion of the first corrugated pipe (20) is coupled to a first end portion (21a) of a tubular element (21) forming part of said connection means (21, 22), where in particular:
 - the tubular element (21, 23) has at least one axial stretch of surface structured so as to engage with an axial stretch of surface of the first corrugated pipe (20), and/or
 - the tubular element (21) has a second end portion (21b) engaged or fitted on a coupling part (2a) of the connector body (2, 40).
7. The device according to Claim 1, comprising at least one tubular element (21, 23) having an end portion (21a) with a surface of a shape substantially complementary to a surface of an end portion of the first corrugated pipe (20), the tubular element (21) having in particular a second end portion (21b) engaged or fitted on a coupling part (2a) of the connector body (2, 40), where in particular said end portion of the first corrugated pipe (20) is axially set at a distance from the coupling part (2a) of the connector body (2, 40), the tubular element (21) having an intermediate portion between its end portions (21a, 21b) that sets in fluid communication an outlet (2b) of the connector body (2, 40) with said end portion of the first corrugated pipe (20).
8. The device according to one or more of Claims 6 to 7, wherein
 - said end portion of the first corrugated pipe (20) extends inside said first end portion (21a) of the tubular element (21), and/or
 - the tubular element (21, 23) is configured as component overmoulded on the first corrugated pipe (20), and/or
 - fitted on the tubular element (21) is at least one external clamping or tightening component (22), and where in particular on the at least one of the first end portion (21a) and the second end portion (21b) of the tubular element (21) a clamping component (22) is fitted, made in particular of metal material, operative for withholding the tubular element (21) on the coupling part (2a) of the connector body (2, 40), or on said end portion of the first corrugated pipe (20).

9. The device according to one or more of the preceding claims, wherein at least one end portion of the second pipe (30) is coupled to a first end portion of a connection element (42), the connection element (42) having at least one axial stretch of surface structured so as to engage with an axial stretch of surface of the second pipe (30).

10. The device according to Claim 9, wherein

- said stretches of surface have each an alternation of reliefs and recesses, the reliefs of the stretch of surface of the connection element (42) being engaged in recesses of the stretch of surface of the second pipe (30), and the reliefs of the stretch of surface of the second pipe (30) being engaged in recesses of the stretch of surface of the connection element (42),
and/or

- the connection element (42) has a second end portion engaged or fitted on a further coupling part (41) made in the connector body (2, 40) or in a coating (40) of the latter, where in particular on the second end portion of the connection element (42) there is fitted a mechanical clamping component (43), made in particular of metal material, operative for withholding in position the connection element (42) on the further coupling part (41) of the connector body (2, 40) or of its coating (40),
and/or

- the connection element (42) operates in a fluid-tight way on both of the pipes (20, 30) and/or wherein the connection element (42) is overmoulded on both of the pipes (20, 30).

11. The device according to Claims 6 and 9, wherein:

- the tubular element (21) and the connection element (42) are made of a single piece, and/or
- the connection element (42) is overmoulded at least in part on the tubular element (21) and on the second pipe (30),
and/or

- the tubular element (21, 23) and/or the connection element (42) is/are made of

- an elastic synthetic material, in particular an elastomer, and/or

- a material designed to shrink following upon a thermal stress, such as a heat-shrinking material, or following upon the cessation of a mechanical or thermal stress, such as a material with shape-memory effect.

12. The device according to Claim 6, wherein the tubular element (21) operates in a fluid-tight way on both of the pipes (20, 30) and/or is overmoulded on both of

the pipes (20, 30).

13. A method for fabricating an anti-flooding safety device (1) according to one or more of the preceding claims, comprising the steps of

i) providing the connector body (2, 40);

ii) providing the first pipe (20);

iii) providing the second pipe (30);

iv) coupling the first pipe (20) and the second pipe (30) to the connector body (2, 40) with at least one part of the first pipe (20) extending longitudinally inside the second pipe (30), wherein step ii) comprises the operation of forming the first pipe (20) as a corrugated pipe made of polypropylene, such that, following step iv) a gap (31) designed to convey and/or withhold possible leakage liquid is defined between the two pipes (20, 30).

14. The method according to Claim 13, wherein:

- step i) comprises the operation of forming the connector body (2, 40) with the coupling part (2a), and

- step iv) comprises the operations of providing the tubular element (21), coupling the first end portion (21a) of the tubular element (21) to the end portion of the first corrugated pipe (20) and fitting the second end portion (21b) of the tubular element (21) on the coupling part (2a) of the connector body (2, 40).

15. The method according to Claim 14, wherein step iv) comprises the operation of overmoulding the tubular element (21) on the first corrugated pipe (20).

Patentansprüche

1. Sicherheitsvorrichtung (1) gegen Überschwemmung für ein Haushaltsgerät, insbesondere für das Befüllen mit oder das Einlassen einer Flüssigkeit in das Haushaltsgerät, wobei die Vorrichtung (1) enthält: einen Verbinderkörper (2, 40), ein erstes flexibles Rohr (20) und ein zweites flexibles Rohr (30), wobei im Verbinderkörper (2, 40) eine Leitung (3) in Fluidverbindung mit dem ersten Rohr (20) begrenzt ist und das letztgenannte vorgesehen ist, um eine Flüssigkeit zu befördern, wobei sich wenigstens ein Teil des ersten Rohres (20) in Längsrichtung innerhalb des zweiten Rohres (30) derart erstreckt, dass wenigstens zwischen einem Teil der beiden Rohre (20, 30) ein Spalt (31) gebildet ist, der in der Lage ist, mögliche Leckflüssigkeit zu befördern und/oder zurückzuhalten, und die beiden Rohre (20, 30) flüssigkeitsundurchlässig sind, wobei die Vorrichtung **dadurch gekennzeichnet ist, dass** das erste Rohr

- (20) ein geriffeltes Rohr ist und aus Polypropylen besteht.
2. Vorrichtung nach Anspruch 1, bei der auch das zweite Rohr (30) ein geriffeltes Rohr ist. 5
 3. Vorrichtung nach Anspruch 1, weiterhin enthaltend Ventileinrichtungen (4) zum Absperrern der Flüssigkeit, wobei insbesondere diese Ventileinrichtungen (4) am Verbinderkörper (2, 40) angebracht sind und in einer Ausdehnung der Leitung (3) betätigt werden können, die sich zwischen einem Einlass (3a) und einem Auslass (3b) derselben befindet, und sich insbesondere im Inneren des Spaltes (31) erstreckend Einrichtungen (32) befinden, um zu den Ventileinrichtungen (4) einen Schließbefehl zu senden. 10
 4. Vorrichtung nach wenigstens einem der Ansprüche 1 bis 3, weiterhin enthaltend Erfassungseinrichtungen (33a, 33b). 15
 5. Vorrichtung nach wenigstens einem der vorhergehenden Ansprüche 20
 - enthaltend wenigstens einen elektrischen Draht oder eine elektrische Leitung (32), die sich insbesondere wenigstens teilweise in dem Spalt (31) und/oder wenigstens teilweise auf der Außenseite des ersten geriffelten Rohres (20) und/oder zwischen dem ersten geriffelten Rohr (20) und dem zweiten geriffelten Rohr (30) erstreckt, und/oder 25
 - die Leitung (3) des Verbinderkörpers (2) einen Einlass (3a) und einen Auslass (3b) hat, wobei der Verbinderkörper (2, 40) für die Verbindung entweder des Einlasses (3a) oder des Auslasses (3b) mit dem ersten geriffelten Rohr (20) geformt ist, wobei insbesondere der Verbinderkörper (2, 40) einen Kopplungsteil (2a) hat, in dem der Auslass (3b) definiert ist und an dem mit diesem ein Endabschnitt des ersten geriffelten Rohres (20) in Eingriff steht oder an diesen angepasst ist. 30
 - und/oder 35
 - weiterhin enthaltend Verbindungseinrichtungen (21, 22) zwischen dem Verbinderkörper (2) und dem ersten geriffelten Rohr (20). 40
 6. Vorrichtung nach Anspruch 5, bei der wenigstens ein Endabschnitt des ersten geriffelten Rohres (20) mit einem ersten Endabschnitt (21 a) eines röhrenförmigen Elementes (21) gekoppelt ist, das einen Teil der Verbindungseinrichtungen (21, 22) bildet, wobei insbesondere: 45
 - das röhrenförmige Element (21, 23) wenigstens eine axiale Oberflächenausdehnung hat, die so strukturiert ist, dass sie mit einer axialen 50
- Oberflächenausdehnung des ersten geriffelten Rohres (20) in Eingriff steht, und/oder
- das röhrenförmige Element (21) einen zweiten Endabschnitt (21 b) aufweist, der mit einem Kopplungsteil (2a) des Verbinderkörpers (2, 40) in Eingriff steht oder an diesen angepasst ist.
7. Vorrichtung nach Anspruch 1, enthaltend wenigstens ein röhrenförmiges Element (21, 23), das einen Endabschnitt (21 a) mit einer Oberfläche einer Form hat, die im wesentlichen komplementär zu einer Oberfläche eines Endabschnittes des ersten geriffelten Rohres (20) ist, wobei das röhrenförmige Element (21) insbesondere einen zweiten Endabschnitt (21 b) hat, der mit einem Kopplungsteil (2a) des Verbinderkörpers (2, 40) in Eingriff steht oder an diesen angepasst ist, und insbesondere der Endabschnitt des ersten geriffelten Rohres (20) axial in einem Abstand vom Kopplungsteil (2a) des Verbinderkörpers (2, 40) eingerichtet ist, wobei das röhrenförmige Element (21) einen Zwischenabschnitt zwischen seinen Endabschnitten (21 a, 21 b) hat, der einen Auslass (2b) des Verbinderkörpers (2, 40) mit dem Endabschnitt des ersten geriffelten Rohres (20) in Fluidverbindung bringt. 55
 8. Vorrichtung nach wenigstens einem der Ansprüche 6 bis 7, bei der 60
 - der Endabschnitt des ersten geriffelten Rohres (20) im ersten Endabschnitt (21 a) des röhrenförmigen Elementes (21) verläuft und/oder 65
 - das röhrenförmige Element (21, 23) als Komponente ausgebildet ist, die über das erste geriffelte Rohr (20) geformt ist, und/oder 70
 - an das röhrenförmige Element (21) wenigstens ein externes Klemm- oder Spannbauteil (22) angepasst ist 75
 - und insbesondere an den ersten Endabschnitt (21 a) und/oder den zweiten Endabschnitt (21 b) des röhrenförmigen Elementes (21) ein Klemmbauteil (22) angepasst ist, das insbesondere aus einem Metallmaterial besteht und betätigt werden kann, um das röhrenförmige Element (21) am Kopplungsteil (2a) des Verbinderkörpers (2, 40) oder am Endabschnitt des ersten geriffelten Rohres (20) zurückzuhalten. 80
 9. Vorrichtung nach wenigstens einem der vorhergehenden Ansprüche, bei der wenigstens ein Endabschnitt des zweiten Rohres (30) mit einem ersten Endabschnitt eines Verbindungselementes (42) gekoppelt ist, wobei das Verbindungselement (42) wenigstens eine axiale Oberflächenausdehnung hat, die so aufgebaut ist, dass sie mit einer axialen Oberflächenausdehnung des zweiten Rohres (30) in Eingriff steht. 85

10. Vorrichtung nach Anspruch 9, bei der

- die Oberflächenausdehnungen jeweils einen Wechsel von Reliefs und Aussparungen haben, wobei die Reliefs der Oberflächenausdehnung des Verbindungselementes (42) in Aussparungen der Oberflächenausdehnung des zweiten Rohres (30) eingreifen und die Reliefs der Oberflächenausdehnung des zweiten Rohres (30) in Aussparungen der Oberflächenausdehnung des Verbindungselementes (42) eingreifen, und/oder
- das Verbindungselement (42) einen zweiten Endabschnitt hat, der mit einem weiteren Kopp­ lungsteil (41), der im Verbinderkörper (2, 40) ausgebildet ist, oder einer Beschichtung (40) des letztgenannten in Eingriff steht oder an diesen angepasst ist, wobei insbesondere an den zweiten Endabschnitt des Verbindungsele­ mentes (42) ein mechanisches Klemmbauteil (43) angepasst ist, das insbesondere aus einem Metallmaterial besteht und so betätigt werden kann, dass es in einer Stellung das Verbin­ dungselement (42) an dem weiteren Kupplungs­ teil (41) des Verbinderkörpers (2, 40) oder des­ sen Beschichtung (40) zurückhält, und/oder
- das Verbindungselement (42) fluiddichtend auf beide Rohre (20, 30) wirkt und/oder das Verbin­ dungselement (42) über beide Rohre (20, 30) geformt ist.

11. Vorrichtung nach Anspruch 6 und 9, bei der:

- das röhrenförmige Element (21) und das Ver­ bindungselement (42) aus einem einzigen Stück bestehen und/oder
- das Verbindungselement (42) wenigstens teil­ weise über das röhrenförmige Element (21) und über das zweite Rohr (30) geformt ist und/oder
- das röhrenförmige Element (21, 23) und/oder das Verbindungselement (42)

- aus einem elastischen synthetischen Ma­ terial, insbesondere einem Elastomer, und/ oder
- einem Material bestehen, dass darauf aus­ gelegt ist, infolge einer thermischen Span­ nung zu schrumpfen, wie etwa ein bei Wär­ me schrumpfendes Material, oder infolge der Einstellung einer mechanischen oder thermischen Spannung zu schrumpfen, wie etwa ein Material mit Form-Memoryeffekt.

12. Vorrichtung nach Anspruch 6, bei der das röhrenförmige Element (21) fluiddichtend auf beide Rohre (20, 30) wirkt und/oder über beide Rohre (20, 30) geformt

ist.

13. Verfahren zur Herstellung einer Sicherheitsvorrich­ tung (1) gegen Überschwemmung nach wenigstens einem der vorangehenden Ansprüche, umfassend folgende Schritte:

- i) Bereitstellen des Verbinderkörpers (2, 40);
- ii) Bereitstellen des ersten Rohres (20);
- iii) Bereitstellen des zweiten Rohres (30) und
- iv) Koppeln des ersten Rohres (20) und des zweiten Rohres (30) mit dem Verbinderkörper (2, 40), wobei sich wenigstens ein Teil des ersten Rohres (20) in Längsrichtung im zweiten Rohr (30) erstreckt, wobei: Schritt ii) den Vorgang des Ausbildens des ersten Rohres (20) als geriffeltes Rohr, das aus Polypropylen besteht, umfasst, so dass nach Schritt iv) ein Spalt (31), der dazu bestimmt ist, eine mögliche Leckflüssigkeit zu befördern und/oder zurückzuhalten, zwischen den beiden Rohren (20, 30) ausgebildet wird.

14. Verfahren nach Anspruch 13, bei dem:

- Schritt i) den Vorgang des Ausbildens des Ver­ binderkörpers (2, 40) mit dem Kopp­ lungsteil (2a) umfasst und
- Schritt iv) die Vorgänge des Bereitstellens des röhrenförmigen Elementes (21), des Koppelns des ersten Endabschnittes (21 a) des röhrenförmigen Elementes (21) mit dem Endabschnitt des ersten geriffelten Rohres (20) und des An­ passens des zweiten Endabschnittes (21 b) des röhrenförmigen Elementes (21) an den Kopp­ lungsteil (2a) des Verbinderkörpers (2, 40) be­ inhaltet.

15. Verfahren nach Anspruch 14, bei dem Schritt iv) den Vorgang des Überformens des röhrenförmigen Ele­ mentes (21) auf dem ersten geriffelten Rohr (20) um­ fasst.

Revendications

1. Dispositif (1) de sécurité pour détecter la présence d'une fuite de liquide dans un appareil ménager, en particulier pour le chargement ou l'admission d'un liquide dans l'appareil ménager, le dispositif (1) comprenant un corps de connecteur (2, 40), un premier tuyau flexible (20) et un second tuyau flexible (30), où dans le corps de connecteur (2, 40) un conduit (3) est défini en communication fluïdique avec le premier tuyau (20), ce dernier étant prévu pour acheminer un liquide, et où au moins une partie du premier tuyau (20) s'étend longitudinalement à l'intérieur du second tuyau (30) de telle sorte qu'entre au

- moins une partie des deux tuyaux (20, 30) un espace (31) est défini, qui peut acheminer et/ou retenir le liquide de fuite possible, les deux tuyaux (20, 30) étant imperméables au liquide, ledit dispositif étant **caractérisé en ce que** le premier tuyau (20) est un tuyau en tôle ondulée et est fait de polypropylène.
2. Dispositif selon la revendication 1, dans lequel le second tuyau (30) est aussi un tuyau en tôle ondulée.
 3. Dispositif selon la revendication 1, comprenant en outre un moyen de soupape (4) pour couper le liquide, où en particulier le moyen de soupape (4) est monté sur le corps de connecteur (2, 40) et est opérationnel dans un allongement du conduit (3) qui est à une position intermédiaire entre un orifice d'entrée (3a) et un orifice de sortie (3b) de celui-ci, où en particulier s'étendant à l'intérieur de l'espace (31) se trouve un moyen (32) pour transmettre au moyen de soupape (4) une commande de fermeture.
 4. Dispositif selon au moins l'une des revendications 1 à 3, comprenant en outre un moyen de détection (33a, 33b).
 5. Dispositif selon au moins l'une des revendications précédentes, comprenant au moins un fil ou câble électrique (32) en particulier s'étendant au moins en partie dans ledit espace (31) et/ou au moins en partie sur l'extérieur du premier tuyau en tôle ondulée (20) et/ou entre le premier tuyau en tôle ondulée (20) et le second tuyau en tôle ondulée (30), et/ou dans lequel le conduit (3) du corps de connecteur (2) a un orifice d'entrée (3a) et un orifice de sortie (3b), le corps de connecteur (2, 40) étant formé pour connexion de l'un desdits orifice d'entrée (3a) et orifice de sortie (3b) au premier tuyau en tôle ondulée (20), où en particulier le corps de connecteur (2, 40) a une partie de couplage (2a), dans laquelle est défini ledit orifice de sortie (3b), sur lequel est en prise, ou ajustée, une partie d'extrémité du premier tuyau en tôle ondulée (20), et/ou comprenant en outre un moyen de connexion (21, 22) entre le corps de connecteur (2) et le premier tuyau en tôle ondulée (20).
 6. Dispositif selon la revendication 5, dans lequel au moins une partie d'extrémité du premier tuyau en tôle ondulée (20) est couplée à une première partie d'extrémité (21a) d'un élément tubulaire (21) formant partie dudit moyen de connexion (21, 22), où en particulier :

l'élément tubulaire (21, 23) a au moins un allongement axial de surface structuré de sorte à venir en prise avec un allongement axial de surface
 - du premier tuyau en tôle ondulée (20), et/ou l'élément tubulaire (21) a une seconde partie d'extrémité (21b) en prise ou ajustée sur une partie de couplage (2a) du corps de connecteur (2, 40).
 7. Dispositif selon la revendication 1, comprenant au moins un élément tubulaire (21, 23) ayant une partie d'extrémité (21a) avec une surface d'une forme sensiblement complémentaire d'une surface d'une partie d'extrémité du premier tuyau en tôle ondulée (20), l'élément tubulaire (21) ayant en particulier une seconde partie d'extrémité (21b) en prise ou ajustée sur une partie de couplage (2a) du corps de connecteur (2, 40), où en particulier ladite partie d'extrémité du premier tuyau en tôle ondulée (20) est axialement placée à une distance de la partie de couplage (2a) du corps de connecteur (2, 40), l'élément tubulaire (21) ayant une partie intermédiaire entre ses parties d'extrémité (21a, 21b) qui place en communication fluïdique un orifice de sortie (2b) du corps de connecteur (2, 40) avec ladite partie d'extrémité du premier tuyau en tôle ondulée (20).
 8. Dispositif selon au moins l'une des revendications 6 à 7, dans lequel ladite partie d'extrémité du premier tuyau en tôle ondulée (20) s'étend à l'intérieur de ladite première partie d'extrémité (21a) de l'élément tubulaire (21), et/ou l'élément tubulaire (21, 23) est configuré comme un composant surmoulé sur le premier tuyau en tôle ondulée (20), et/ou au moins un composant d'attache ou serrage externe (22) est ajusté sur l'élément tubulaire (21), et où en particulier sur l'au moins une des première (21a) et seconde (21b) parties d'extrémité de l'élément tubulaire (21) est ajusté un composant d'attache (22), formé en particulier à partir d'un matériau métallique, opérationnel pour retenir l'élément tubulaire (21) sur la partie de couplage (2a) du corps de connecteur (2, 40), ou sur ladite partie d'extrémité du premier tuyau en tôle ondulée (20).
 9. Dispositif selon au moins l'une des revendications précédentes, dans lequel au moins une partie d'extrémité du second tuyau (30) est couplée à une première partie d'extrémité d'un élément de connexion (42), l'élément de connexion (42) ayant au moins un allongement axial de surface structuré de sorte à venir en prise avec un allongement axial de surface du second tuyau (30).
 10. Dispositif selon la revendication 9, dans lequel lesdits allongements de surface ont chacun une alternance de reliefs et d'évidements, les reliefs de l'allongement de surface de l'élément de connexion (42) étant en prise dans les évidements de l'allongement de surface du second tuyau (30), et les re-

liefs de l'allongement de surface du second tuyau (30) étant en prise dans des évidements de l'allongement de surface de l'élément de connexion (42), et/ou

l'élément de connexion (42) a une seconde partie d'extrémité en prise ou ajustée sur une autre partie de couplage (41) formée dans le corps de connecteur (2, 40) ou dans un revêtement (40) de ce dernier, où en particulier sur la seconde partie d'extrémité de l'élément de connexion (42) est ajusté un composant d'attache mécanique (43), formé en particulier à partir de matériau métallique, opérationnel pour retenir en position l'élément de connexion (42) sur l'autre partie de couplage (41) du corps de connecteur (2, 40) ou de son revêtement (40), et/ou

l'élément de connexion (42) fonctionne d'une manière étanche aux fluides sur les deux tuyaux (20, 30) et/ou dans lequel l'élément de connexion (42) est surmoulé sur les deux tuyaux (20, 30).

11. Dispositif selon les revendications 6 et 9, dans lequel :

l'élément tubulaire (21) et l'élément de connexion (42) sont faits d'une seule pièce, et/ou l'élément de connexion (42) est surmoulé au moins en partie sur l'élément tubulaire (21) et sur le second tuyau (30), et/ou

l'élément tubulaire (21, 23) et/ou l'élément de connexion (42) sont formés à partir d'un matériau synthétique élastique, en particulier un élastomère, et/ou d'un matériau conçu pour rétrécir après une contrainte thermique, comme un matériau thermo-rétrécissable, ou après la cessation d'une contrainte thermique ou mécanique, tel qu'un matériau avec un effet de mémoire de forme.

12. Dispositif selon la revendication 6, dans lequel l'élément tubulaire (21) fonctionne d'une manière étanche aux fluides sur les deux tuyaux (20, 30) et/ou est surmoulé sur les deux tuyaux (20, 30).

13. Procédé de fabrication d'un dispositif (1) de sécurité pour détecter la présence d'une fuite de liquide selon une ou plus des revendications précédentes, comprenant les étapes consistant à

i) fournir le corps de connecteur (2, 40) ;
 ii) fournir le premier tuyau (20) ;
 iii) fournir le second tuyau (30) ;
 iv) coupler le premier tuyau (20) et le second tuyau (30) au corps de connecteur (2, 40) avec au moins une partie du premier tuyau (20) s'étendant longitudinalement à l'intérieur du second tuyau (30),

dans lequel l'étape ii) comprend l'opération consistant à former le premier tuyau (20) comme un tuyau en tôle ondulée fait de polypropylène, de telle sorte que, à la suite de l'étape iv) un espace (31) conçu pour convoyer et/ou retenir le liquide de fuite possible est défini entre les deux tuyaux (20, 30).

14. Procédé selon la revendication 13, dans lequel :

l'étape i) comprend l'opération de formation du corps de connecteur (2, 40) avec la partie de couplage (2a), et

l'étape iv) comprend l'opération de fourniture de l'élément tubulaire (21), de couplage de la première partie d'extrémité (21a) de l'élément tubulaire (21) à la partie d'extrémité du premier tuyau en tôle ondulée (20) et d'ajustement de la seconde partie d'extrémité (21b) de l'élément tubulaire (21) sur la partie de couplage (2a) du corps de connecteur (2, 40).

15. Procédé selon la revendication 14, dans lequel l'étape iv) comprend l'opération de surmoulage de l'élément tubulaire (21) sur le premier tuyau en tôle ondulée (20).

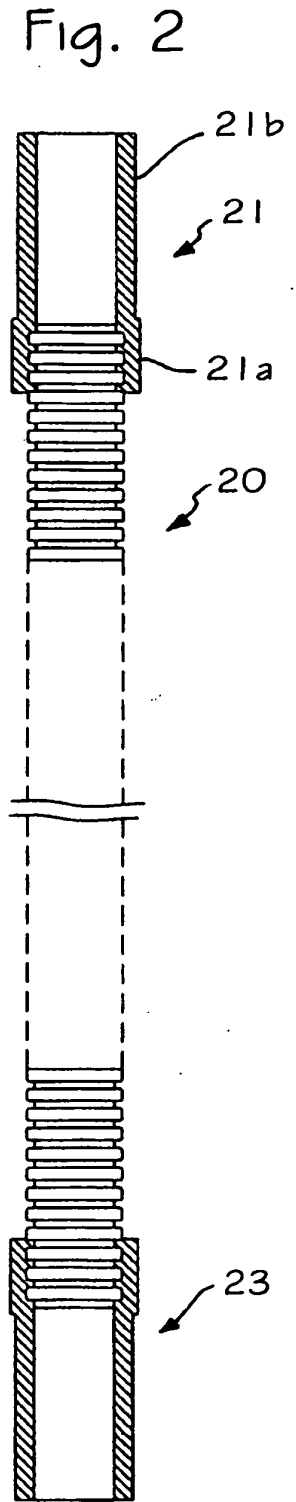
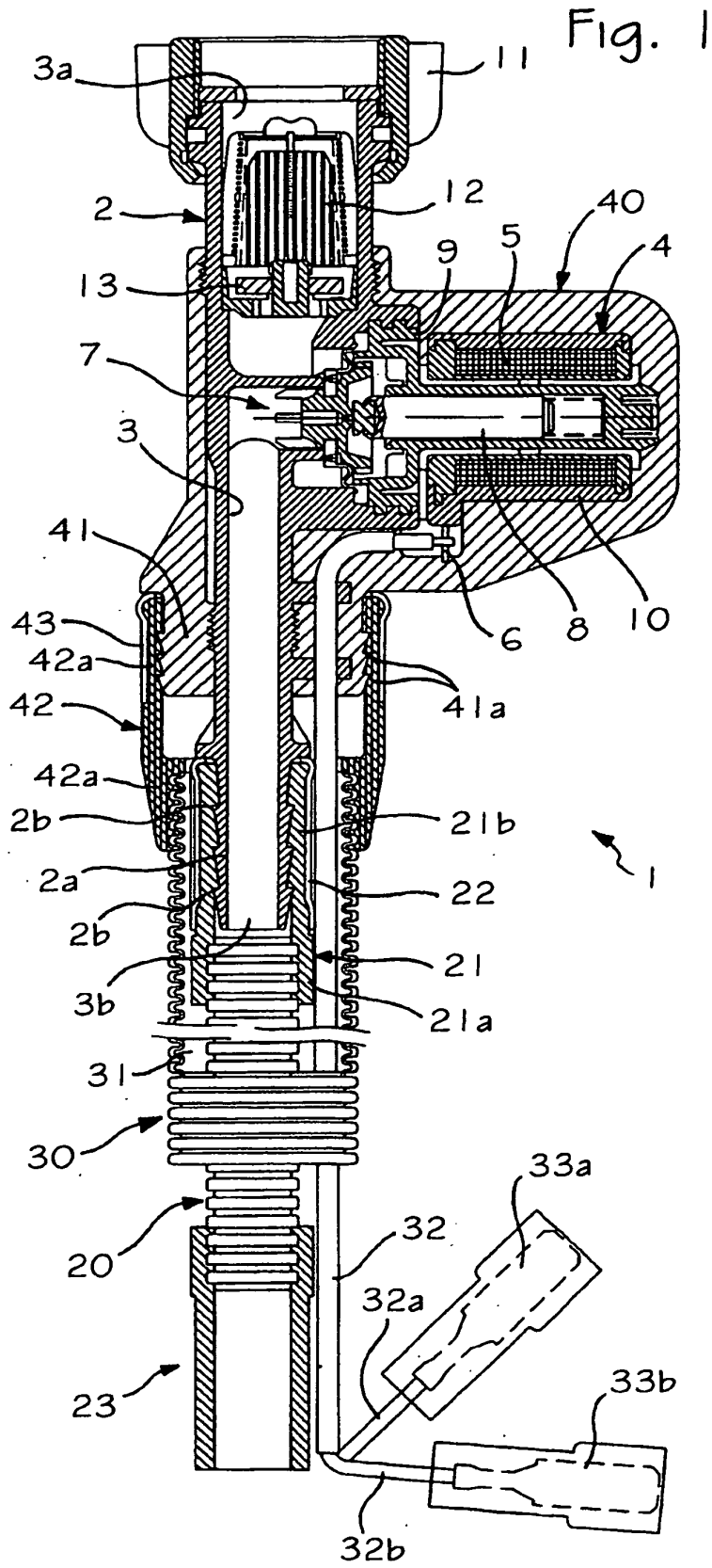

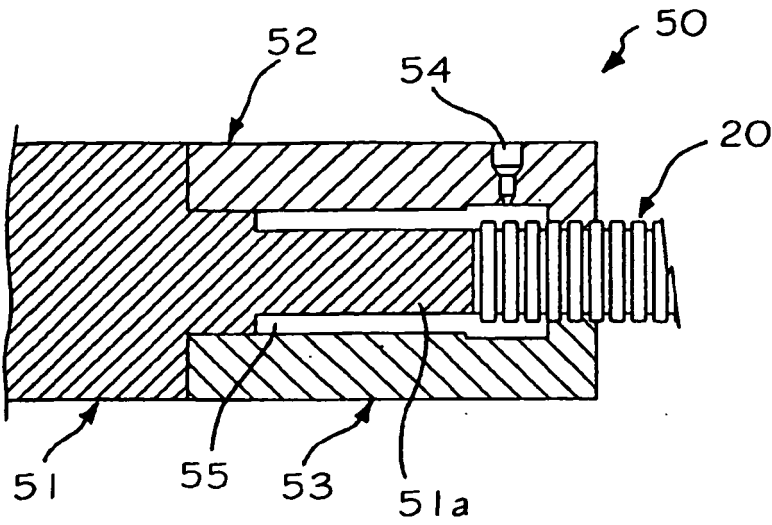

Fig. 3

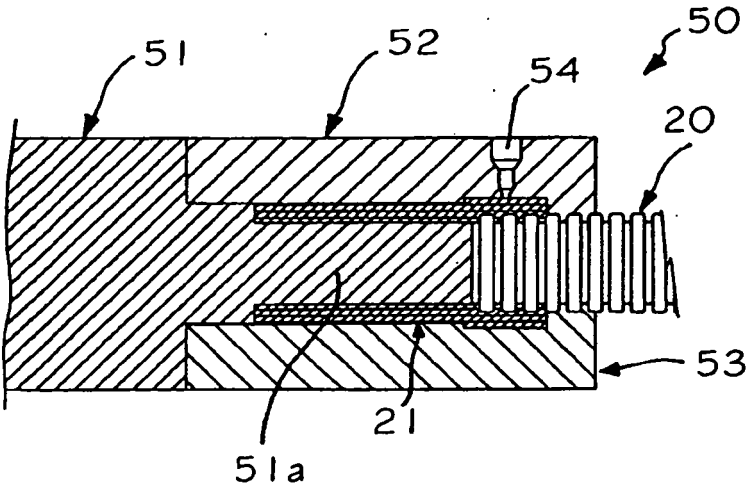

Fig. 4

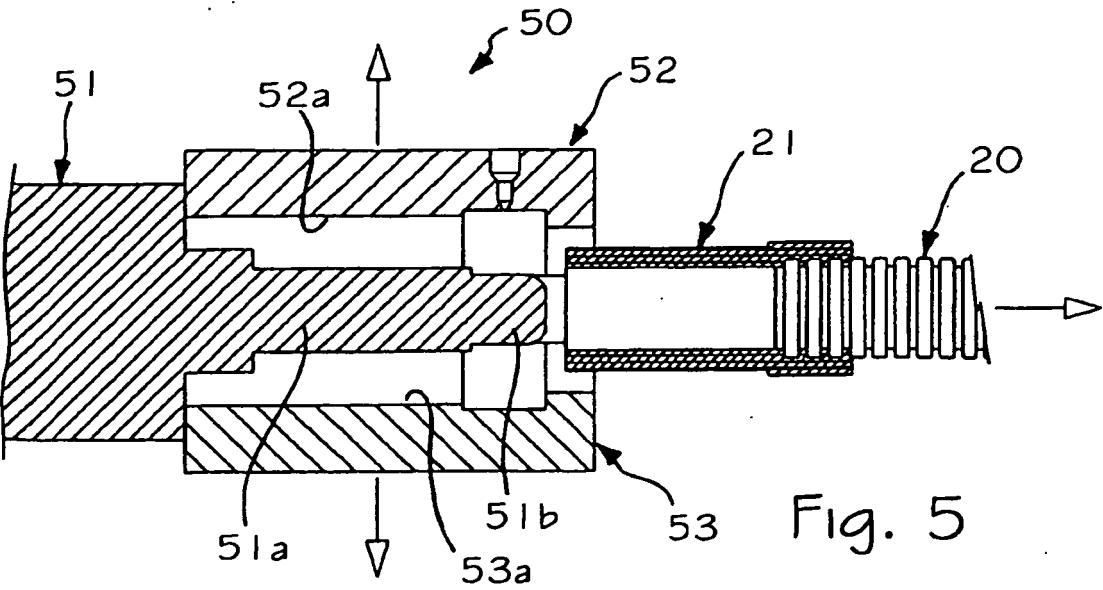

Fig. 5

REFERENCES CITED IN THE DESCRIPTION

This list of references cited by the applicant is for the reader's convenience only. It does not form part of the European patent document. Even though great care has been taken in compiling the references, errors or omissions cannot be excluded and the EPO disclaims all liability in this regard.

Patent documents cited in the description

- FR 2742514 A [0005] [0011] [0024]
- IT 1207365 B [0005]
- DE 10126104 A [0005]