

(19)



(11)

EP 2 314 779 B1

(12)

EUROPEAN PATENT SPECIFICATION

(45) Date of publication and mention of the grant of the patent:
28.12.2016 Bulletin 2016/52

(51) Int Cl.:
E04B 1/76 (2006.01) E04B 2/86 (2006.01)

(21) Application number: **10188500.2**

(22) Date of filing: **22.10.2010**

(54) **Laminated insulating panel, use of such an insulating panel and method for arranging such an insulating panel**

Laminierte Isolierplatte, Verwendung einer solchen Platte, und Verfahren zum Anordnen einer solchen Platte

Panneau d'isolation stratifié, utilisation d'un tel panneau d'isolation, et procédé pour disposer un tel panneau d'isolation

(84) Designated Contracting States:
AL AT BE BG CH CY CZ DE DK EE ES FI FR GB GR HR HU IE IS IT LI LT LU LV MC MK MT NL NO PL PT RO RS SE SI SK SM TR

(74) Representative: **D'Halleweyn, Nele Veerle Trees Gertrudis et al Arnold & Siedsma Bezuidenhoutseweg 57 2594 AC The Hague (NL)**

(30) Priority: **23.10.2009 BE 200900654**

(43) Date of publication of application:
27.04.2011 Bulletin 2011/17

(56) References cited:
**EP-A1- 1 640 521 EP-A2- 0 285 518
CH-A- 345 140 DE-U1- 29 904 476
FR-A1- 2 485 590 FR-A1- 2 629 505
GB-A- 1 202 871 US-A- 3 106 751**

(73) Proprietor: **Cleys, Kris 9130 Kieldrecht (BE)**

(72) Inventor: **Cleys, Kris 9130 Kieldrecht (BE)**

EP 2 314 779 B1

Note: Within nine months of the publication of the mention of the grant of the European patent in the European Patent Bulletin, any person may give notice to the European Patent Office of opposition to that patent, in accordance with the Implementing Regulations. Notice of opposition shall not be deemed to have been filed until the opposition fee has been paid. (Art. 99(1) European Patent Convention).

Description

[0001] The present invention relates to insulating panels, more particularly to laminated insulating panels comprising a base layer of an insulating material and a cover layer of a mechanically stronger material.

[0002] Laminated insulating panels for use in roof covering applications are known in the field. In a known embodiment the base layer consists of an insulating panel of extruded polystyrene and the cover layer of a hard concrete layer adhering thereto. These insulating panels provide the advantage that using a single product both insulation and a weather-resistant finishing layer can be arranged on existing flat roofs. In this application the insulating panels are hooked into each other with a tongue and groove system and the arranged insulating panels remain in place on the flat roof due to their own weight and/or weights arranged on the panels along the edge of the roof. Rainwater seeping through between the joints of the insulating panels flows over the watertight underlying roof structure to the provided discharge points.

[0003] American patent no. 4,587,164, granted to Thurman Freeman, describes a composite panel for constructing a roof surface, consisting of three layers. The base layer is an insulating foam plastic such as polystyrene. The cover layers consist on the one hand of an inorganic concrete layer enriched with wood fibres and on the other of a specific type of chipboard.

[0004] A drawback of the known combined insulating and finishing panels is that they are only suitable for horizontal applications.

[0005] FR-A-80 14296 discloses a laminated insulation panel and its use.

[0006] It is a disadvantage of these known insulation panels that they provide reduced attachment strength and insulation at their joints.

[0007] EP 1 640 521 discloses a laminated insulation panel according to the preamble of claim 1 and a method for arranging one or more isolating panels on a surface according to the preamble of claim 10, wherein an adhesive foam is applied to the back of the isolating panel(s) and/or on the surface, in order to stick the isolating panel(s) on the surface.

[0008] According to an aspect of the invention, there is provided a laminated insulating panel according to claim 1.

[0009] According to another aspect of the invention, the use of such a laminated insulating panel is provided as insulating layer for an upright wall.

[0010] According to yet another aspect of the invention, the use of such a laminated insulating panel is provided as lost formwork for erecting cast structures.

[0011] According to yet another aspect of the invention, there is provided a method according to claim 10.

[0012] CH 345140 discloses a method for arranging a formwork for a cast structure according to the preamble of claim 12. It is a disadvantage of this known method that it doesn't produce readily insulated walls, and that

it may suffer from leakage of liquids during the casting process. It is an object of embodiments of this invention to overcome these disadvantages.

[0013] Deemed to be insulating material are, among others, the insulating materials usual in the building industry, such as materials having a heat conduction coefficient (λ -value) of less than 0.05 to 0.06 W/mK, and preferably those having a heat conduction coefficient (λ -value) of less than 0.035 W/mK.

[0014] Deemed to be mechanically stronger material are, among others, the finishing materials usual in the building industry, and particularly materials with a sufficient hardness to resist possible impact by small objects, hail, pebbles and the like, and sufficient stiffness to remain planar in vertical position under possible load.

[0015] The invention is based inter alia on the insight that in vertical applications the laminated insulating panels must be adhered fixedly to the wall on which they are arranged. The invention is moreover based on the insight that it is not desirable for bolts, nails or other connecting pieces to remain visible on the outside of these panels, which also serve as outer wall finishing.

[0016] It is an advantage of the invention that an adhesive product which expands significantly after being applied, such as for instance a product on the basis of polyurethane foam, can be used at the position of the space created on the attaching side. The use of such products combines a good adhesion of the insulating panels at the position of the edges with thermal sealing of the joints between mutually adjacent insulating panels, whereby possible undesirable cold bridges are avoided at the position of these joints.

[0017] As part of the invention said side wall comprises a recess extending over the whole periphery of the insulating panel. As part of the invention said at least one side wall has a chamfering of the edge of the insulating panel on the attaching side.

[0018] The stated "recess" and "chamfering" must be understood to be a specification of the shape characteristics of the invention in respect of an elementary panel with the form of a rectangular prism or parallelepiped.

[0019] According to the invention the attaching side of the whole periphery of the insulating panel has a structure which improves the adhesion to the wall.

[0020] It is an advantage of the invention that the structure of the attaching side enhances the adhesion to an existing wall using a glue or adhesive product, such as for instance a silicone-based product. This is for instance achieved by giving the attaching side a certain roughness or by arranging an uneven pattern thereon. An additional advantage of such a structure is that the adhesive spreads evenly when the insulating panel is pressed on and positioned, without the adhesive producing a significant counterpressure and pushing the insulating panel back.

[0021] It is an additional advantage of the invention that the structure of the attaching side enables the use of the insulating panels as lost formwork for cast struc-

tures, particularly concrete structures, wherein the cast structure has a suitable insulating layer and a finishing layer immediately after curing. In this application the structure of the attaching side enhances the adhesion of the cast material to the base layer.

[0022] In a preferred embodiment at least one of the side surfaces comprises a recess for receiving a sealing strip. In a specific embodiment this recess is a groove substantially parallel to an edge of the outer surface of the cover layer.

[0023] An embodiment of the invention is based inter alia on the insight that the laminated insulating panels must form a watertight whole in some vertical applications, particularly on outside walls, in order to avoid accumulation of water occurring between the insulating panels and the underlying wall.

[0024] It is an advantage of this embodiment that a sealing strip of a watertight material, such as for instance rubber or silicone-based adhesive, can be arranged in the joints between mutually adjacent panels without the joints having to be widened for this purpose. As a result a continuous watertight whole of insulating panels can be obtained without unnecessary cold bridges occurring between the mutually adjacent panels.

[0025] In a preferred embodiment the cover layer consists substantially of concrete. This embodiment has the advantage that the cover layer is weather-resistant and is substantially non-expanding.

[0026] In a preferred embodiment the base layer consists substantially of a foam-like plastic or a plastic foam. In a specific embodiment said foam-like plastic comprises polystyrene. In another embodiment the base layer consists substantially of cellular glass or a similar mineral foam.

[0027] An embodiment of the present invention consists of the use of said laminated insulating panels as lost formwork for erecting cast structures. It is an advantage of this use that the cast structure has a suitable insulating layer and a finishing layer immediately after curing.

American patent no. 4,459,334, granted to Robert Blaupied et al., describes a composite panel for use in the construction industry, consisting of a core of plastic foam and a cover layer consisting of a combination of aluminium foil and glass fibre mat. The core has a good thermal insulation and fire-retardant properties, while the cover layer provides an improved mechanical strength. This patent describes none of the above described measures necessary for a vertical application of the panels.

[0028] The foregoing and other advantages of the invention will be further elucidated with reference to the following figures and descriptions, in which:

Figure 1 illustrates a prior art insulating panel;

Figure 2 illustrates a preferred embodiment of the insulating panel according to the present invention;

Figure 3 illustrates another embodiment of the insulating panel according to the present invention;

Figure 4 illustrates the use of an insulating panel according to the present invention as lost formwork for a cast structure;

Figure 5 illustrates a preferred embodiment of the insulating panel according to the invention;

Figure 6 is a schematic view of the use of the insulating panel according to the invention as formwork panel; and

Figure 7 is a schematic view of the use of the insulating panel according to the invention as insulating and finishing layer on an existing wall.

[0029] As shown in Figure 1, the known laminated insulating panels **100** have substantially an insulating base layer **101** and a cover layer **102** for improving the mechanical properties, particularly on the outer side of the structure to be insulated.

[0030] By way of reference Figure 1 also shows attaching side **103**, free side **104** and several side walls **105**.

[0031] The preferred embodiment of insulating panel **100** according to the invention illustrated in Figure 2 has the same laminated structure.

[0032] For insulating base layer **101** a material is chosen which has a sufficiently low thermal (and optionally acoustic) conduction. The material is chosen such that the base layer is sufficiently stiff per se and is suitable for adhering. Diverse types of plastic foam are thus suitable among others. It is moreover advantageous to select a fireproof material.

[0033] For the manufacture of cover layer **102** a material is chosen which has the desired hardness and stiffness and can well withstand the atmospheric conditions to be expected. Concrete mixtures such as concrete are suitable materials for cover layer **102** because they are weather-resistant and substantially non-expanding. They moreover provide a good fire resistance. Other materials with similar properties can likewise be used, preferably materials with a density of around 2000 kg/m³.

[0034] Side walls **105** are chamfered on attaching side **103**, this forming recesses **106** which create a space or cavity between the wall and insulating base layer **101** when two identical insulating panels **100** are placed adjacently of each other. This cavity allows the use of highly expanding types of adhesive, such as polyurethane foam, which on the one hand ensure an excellent adhesion of insulating panels **100** to the wall and to each other, and on the other form a thermal break of the cold bridges which could occur at the position of the joints. Because all side walls **105** are chamfered in this manner according to the invention, the resulting space **106** extends over the whole periphery of insulating panel **100**.

[0035] In a preferred embodiment two mutually oppo-

site sides, for instance the sides which stand vertically after placing of the panel, have a chamfering extending in each direction up to a distance of about 15 mm from the imaginary edge.

[0036] In another preferred embodiment two mutually opposite sides, for instance the sides which stand vertically after placing of the panel, have a chamfering extending in each direction up to a distance of about 10 mm from the imaginary edge. This preferred embodiment has the advantage of being particularly suitable for the use of the insulating panel as formwork for cast structures, wherein said chamferings form recesses for receiving a known concrete formwork triangular prism.

[0037] In yet another preferred embodiment two mutually opposite sides, for instance the sides which stand vertically after placing of the panel, have a chamfering extending in each direction up to a distance of about 25 mm from the imaginary edge. This preferred embodiment has the advantage that, when applied to very flat walls, the adhesion to the wall can be improved by increasing the adhesion surface area at the position of the vertical joins.

[0038] Attaching side **103** has a structure which improves the adhesion to a wall, for instance by an improved adhesion to adhesive products. This effect is obtained by making attaching side **103** sufficiently rough or uneven. The structure is preferably arranged by milling grooves into the base layer in one or more directions. It is also possible to arrange a structure by pressing an optionally heated die or template into the material of the base layer.

[0039] Fixedly adhering insulating panels **100** to an underlying existing wall preferably takes place with an adhesive product on the basis of silicone. It is advantageous to use an adhesive product which produces a tensile strength of at least about 2.65 MPa.

[0040] In the base layer, in the cover layer, or partially in both, side walls **105** have a recess **107** embodied as a groove for receiving a sealing strip, for instance a sealing strip of rubber. This strip has the purpose of making the entirety of mutually adjacent insulating panels **100** watertight. Thus avoided is that accumulation of water occurs between a wall, in particular an outside wall, and insulating panels **100** arranged thereon. In a preferred embodiment recess **107** is situated about 15 mm from outer wall **104**. Recess **107** is preferably a groove of about 15 mm. The form of the groove moreover preferably corresponds with the profile of the sealing strip to be inserted.

[0041] A judiciously formed sealing strip can be used to realize a pivoting connection. Required for this purpose is that during placing the sealing strip is sufficiently flexible to seal the join completely when the insulating panels are placed in the desired relative position. Such a pivoting connection in the horizontal joins for instance allows placing of insulating panels against a wall which is not perfectly vertical, without undesirable openings thereby occurring between the adjacent insulating panels. It is like-

wise possible to provide such a pivoting connection in the vertical joins.

[0042] The embodiment of Figure 3 illustrates an alternative form for recesses **106**, which are embodied only partially as chamfering. Insulating panel **100** is moreover provided on the free side **104** with an additional layer **108**, which can be arranged because of its specific mechanical properties or for decorative purposes.

[0043] Figure 4 illustrates the use of insulating panels according to the invention as lost formwork for cast structures. The arrangement of figure 4 shows two mirrored rows of insulating panels according to the invention which are placed opposite each other and form a channel in which concrete can be cast such that an already insulated and finished wall results immediately after curing of the concrete.

[0044] The channel is bounded by insulating panels according to the invention, only four of which are shown for the sake of simplicity in the figure, and optionally one or more traditional removable formwork plates **401** at the position of the sides where connection to further cast structures is provided. The insulating panels are placed with base layer **101** directed toward the space in which the concrete is cast, and cover layer **102** is directed toward the outer side of the wall. Known fixing means **402** can be used to hold the insulating panels in the correct position during casting of the concrete and during curing. Reinforcement **403** can also be arranged in known manner in the channel, for instance in the form of so-called concrete reinforcing bars, so that the resulting structure will comprise a core of reinforced concrete.

[0045] In this application the adhesion of the insulating panels to the wall only takes place as the wall cures. It is therefore advantageous in the construction of the formwork structure to already mutually connect the insulating panels by providing a suitable connecting means in recesses **107**. This connecting means can comprise a flexible material or a semi-hard or hard material. A flexible material is appropriate when the different insulating panels do not have lie in the same plane as each other, for instance in order to form a slightly curved wall. A hard, straight connection will provide a straight wall with additional formwork strength.

[0046] In the application of the insulating panels as lost formwork, recesses **106** are preferably formed such that seepage of concrete liquid into the join is prevented. In a specific preferred embodiment recesses **106** are formed such that the free space formed by these recesses can be efficiently sealed before casting of the concrete. It is advantageous to provide chamfering of the vertical sides in the insulating panels which, after erection of the insulating panels, forms intermediate spaces which can be efficiently sealed, for instance by arranging a quantity of insulating material in solid form or as sprayed foam. If insulating material is arranged in solid form, it can be very easily cut to size because the space to be filled is suitable for receiving a wedge-shaped piece of material. It is not therefore necessary here to produce

filling pieces of a complex form. In an alternative embodiment recesses **106** are formed such that a flat bar can be adhered in efficient manner over the formed seam. After placing the recesses **106** preferably form a wide, shallow groove in which the flat bar can be precisely arranged.

[0047] Although the above description related to the formation of a channel for erecting a wall, it will be apparent to the skilled person that the insulating panels according to the invention can equally well be used for horizontal applications such as ceiling formwork. The insulating panels can be placed inter alia on available concrete beams, irrespective of whether these are of the prefabricated type, or be cast in situ.

[0048] In addition to the above described embodiments, wherein the insulating panels according to the invention are used as direct concrete formwork, it is also possible, among other applications, to place the insulating panels according to the invention against a formwork wall of the known type.

[0049] Figure 5 shows a preferred embodiment of the insulating panel according to the invention. Such an insulating panel is for instance 1200 mm wide and 60 mm high, with a thickness depending on the desired application. The thickness of the insulating base layer **101** here substantially determines the insulating capacity of the insulating panel. Cover layer **102** preferably consists substantially of concrete. Free side **104** and attaching side **103** are also indicated, wherein attaching side **103** is provided with a structure in the form of a groove pattern which improves the adhesion to the wall. Recesses **106** are embodied as chamferings of the side walls which are vertical when placed. Recess **107** is provided in the vertical joints in order to receive an elastic sealing strip.

[0050] The components of a longitudinal ball hinge are also visible on those side walls of the insulating panel situated at the top and bottom in the figure. The insulating panel is preferably embodied such that, in placed situation, a male (protruding) part of the ball hinge is provided at the top and a female (recessed) part at the bottom. During placing the male part of an insulating panel placed in a lower position couples to the female part of an insulating panel placed in a higher position. The male part and the female part are preferably rounded so that a pivotable hinge is formed and so that mutually connecting insulating panels can be placed at a small mutual angle without the horizontal joint becoming visibly larger. Small variations in verticality of the wall to be covered can thus be compensated. The combination of a male part provided on the upper side of the insulating panel and a female part provided on the underside of the insulating panel has the additional advantage that, in placed situation, seeping of rainwater into the horizontal joints is prevented. It is useful in this embodiment to adapt the course of groove **105** for receiving a sealing strip to the presence of the ball hinge, for instance by having the groove slope from the onset of the male part at the top of the insulating panel. The groove preferably runs obliquely toward a

point closer to the free side at the bottom of the insulating panel. In this way in seeping rainwater is guided away from the ball hinge by the sealing strip of the wall.

[0051] In addition to the described ball hinge, wherein a protruding and a recessed part couple to each other, a simpler overlapping hinge is also possible, wherein the edge of the insulating panel situated at the top in the placed situation has a recess on the free side, which recess couples to a modified recess on the attaching side in the bottom edge of a higher placed insulating panel.

[0052] Figure 6 is a schematic top view serving to illustrate the use of the insulating panel according to the invention as formwork for a cast structure **603**, preferably a concrete structure. The insulating panels are placed in continuous planes on either side of the structure to be erected, wherein a connecting means **601** is provided in recesses **107** in order to consolidate the whole. Recesses **106** are filled with a suitable sealing means in order to prevent penetration of concrete liquid into the joints, shown here as a concrete formwork triangular prism **602**, preferably of PVC. The joints between the insulating panels and between the insulating panels and wedge **106** are shown enlarged in Figure 6 for the sake of clarity. The space between the thus formed formwork surfaces is filled up with the casting mortar, preferably concrete, which when cured will form structure **603**.

[0053] Figure 7 is a schematic top view serving to illustrate the use of the insulating panel according to the invention as insulating and finishing layer on an existing wall **701**. The insulating panels are adhered with their attaching side **103** to wall **701** at diverse locations by means of an adhesive **702**. Adhesive **702** preferably ensures an immediate stabilization of the insulating panel during the placing operations. The recesses provided at the position of the vertical side walls are filled with another adhesive **703**, preferably a foam-like adhesive. Sealing strips **704** are arranged in the recesses provided for this purpose so that a watertight whole is formed with the free sides **104** of the placed insulating panels.

[0054] Although the invention is described above on the basis of determined embodiments, the skilled person will appreciate that other variants of the stated features are possible which nevertheless fall within the scope of the described invention. The invention is thus not limited by the described embodiments, but is defined by the appended claims.

Claims

1. Laminated insulating panel (100) with an attaching side (103) for placing against a wall (701), a free side (104) and a number of side walls (105), comprising a base layer (101) of an insulating material and a cover layer (102) of a mechanically stronger material, where at least one side wall (105) on the attaching side (103) is formed such that in the placed situation a space adjacent to the attaching side (103)

- is created between two identical insulating panels (100) arranged adjacently of each other, between the wall and said base layer;
wherein
said space is created by a first recess (106) which extends over the whole periphery of the insulating panel (100), between said at least one side wall (105) and the attaching side (103); wherein said space is suitable for use of an adhesive product which expands significantly after being applied, **characterized in that** said first recess (106) is formed by chamfering the edge of the insulating panel on said attaching side (103).
2. Laminated insulating panel (100) as claimed in claim 1, **characterized in that** at least a part of the attaching side (103) has a structure improving the adhesion to the wall.
 3. Laminated insulating panel (100) as claimed in any of the foregoing claims, **characterized in that** at least one of the side walls (105) comprises a second recess (107) for receiving a sealing strip, said second recess (107) being a groove substantially parallel to an edge of the free side (104).
 4. Laminated insulating panel (100) as claimed in claim 3, **characterized in that** the second recess (107) extends over the whole periphery of the insulating panel (100).
 5. Laminated insulating panel (100) as claimed in any of the foregoing claims, **characterized in that** the cover layer (102) consists substantially of concrete.
 6. Laminated insulating panel (100) as claimed in any of the foregoing claims, **characterized in that** the base layer (101) consists substantially of a foam-like plastic.
 7. Laminated insulating panel (100) as claimed in claim 6, **characterized in that** said foam-like plastic comprises polystyrene.
 8. Use of the laminated insulating panel (100) as claimed in any of the claims 1 to 7 as insulating layer on an upright wall.
 9. Use of the laminated insulating panel (100) as claimed in any of the claims 1 to 7 as lost formwork for erecting a cast structure.
 10. Method for arranging against a wall (701) a laminated insulating panel (100) with an attaching side (103), a free side (104) and a number of side walls (105), which insulating panel (100) comprises a base layer (101) of an insulating material and a cover layer (102) of a mechanically stronger material, wherein at least one side wall (105) on the attaching side (103) is formed such that in the placed situation a space adjacent to the attaching side (103) is created between two identical insulating panels (100) arranged adjacently of each other, the method comprising: arranging a first adhesive (702) between the wall and the attaching side (103);
wherein
said space is created between the wall and said base layer, by a first recess (106) which extends over the whole periphery of the insulating panel (100), between said at least one side wall (105) and the attaching side (103);
and wherein
the method further comprises arranging a second adhesive (703) in the space adjacent to the attaching side (103) such that the insulating panel (100) adheres to said wall (701) by virtue of said second adhesive (703), **characterized in that** said first recess (106) is formed by chamfering the edge of the insulating panel on said attaching side (103).
 11. Method as claimed in claim 10, wherein at least one of the side walls (105) comprises a second recess (107) for receiving a sealing strip, further comprising of: arranging a sealing strip (704) in the second recess (107).
 12. Method for arranging a formwork for a cast structure (603) with a laminated insulating panel (100) with an attaching side (103), a free side (104) and a number of side walls (105), wherein at least one side wall (105) on the attaching side (103) is formed such that in the placed situation one or more spaces adjacent to the attaching side (103) are created between two insulating panels (100) arranged adjacently of each other,
characterized in that the method comprising the steps of: arranging a sealing means (602) in the one or more spaces adjacent to the attaching side and arranging a connecting means (601) in the second recess (107),
and in that said insulating panel (100) comprises a base layer (101) of an insulating material and a cover layer (102) of a mechanically stronger material.

Patentansprüche

1. Laminierte Isolierplatte (100) mit einer Anbringungsseite (103) zum Anbringen an einer Wand (701), einer freien Seite (104) und einer Anzahl von Seitenwänden (105), umfassend eine Grundschicht (101) aus einem Isoliermaterial und eine Deckschicht (102) aus einem mechanisch stärkeren Material, wobei zumindest eine Seitenwand (105) auf der Anbringungsseite (103) derart gebildet ist, dass im angebrachten Zustand ein Zwischenraum neben der

- Anbringungsseite (103) zwischen zwei nebeneinander angeordneten identischen Isolierplatten (100) zwischen der Wand und der Grundschrift hervorgerufen ist,
wobei der Zwischenraum durch eine erste Ausnehmung (106), die sich über den gesamten Umfang der Isolierplatte (100) erstreckt, zwischen der zumindest einen Seitenwand (105) und der Anbringungsseite (103) hervorgerufen ist,
wobei der Zwischenraum für die Verwendung eines Kleberzeugnisses geeignet ist, das sich signifikant ausdehnt, nachdem es aufgebracht ist,
dadurch gekennzeichnet,
dass die erste Ausnehmung (106) durch Abschrägen der Kante der Isolierplatte auf der Anbringungsseite (103) gebildet ist.
2. Laminierte Isolierplatte (100) nach Anspruch 1, **dadurch gekennzeichnet, dass** zumindest ein Teil der Anbringungsseite (103) eine das Kleben an der Wand verbessernde Struktur aufweist.
3. Laminierte Isolierplatte (100) nach einem der vorhergehenden Ansprüche, **dadurch gekennzeichnet, dass** zumindest eine der Seitenwände (105) eine zweite Ausnehmung (107) zur Aufnahme eines Dichtungstreifens aufweist und dass die zweite Ausnehmung (107) eine Nut ist, die im Wesentlichen parallel zu einer Kante der freien Seite (104) verläuft.
4. Laminierte Isolierplatte (100) nach Anspruche 3, **dadurch gekennzeichnet, dass** die zweite Ausnehmung (107) sich über den gesamten Umfang der Isolierplatte (100) erstreckt.
5. Laminierte Isolierplatte (100) nach einem der vorhergehenden Ansprüche, **dadurch gekennzeichnet dass** die Deckschicht (102) im Wesentlichen aus Beton besteht.
6. Laminierte Isolierplatte (100) nach einem der vorhergehenden Ansprüche, **dadurch gekennzeichnet, dass** die Grundschrift (101) im Wesentlichen aus einem schaumartigen Kunststoff besteht.
7. Laminierte Isolierplatte (100) nach Anspruch 6, **dadurch gekennzeichnet, dass** der schaumartige Kunststoff Polystyrol umfasst.
8. Verwendung der laminierten Isolierplatte (100) nach einem der Ansprüche 1 bis 7 als Isolierschicht an einer aufrechten Wand.
9. Verwendung der laminierten Isolierplatte (100) nach einem der Ansprüche 1 bis 7 als verlorene Schalung zum Errichten einer Gussstruktur.
10. Verfahren zum Anordnen einer eine Anbringungsseite (103), eine freie Seite (104) und einer Anzahl von Seitenwänden (105) aufweisenden laminierten Isolierplatte (100) an einer Wand (701), wobei die Isolierplatte (100) eine Grundschrift (101) aus einem Isoliermaterial und eine Deckschicht (102) aus einem mechanisch stärkeren Material umfasst, wobei zumindest eine Seitenwand (105) auf der Anbringungsseite (103) derart gebildet ist, dass im angebrachten Zustand ein Zwischenraum neben der Anbringungsseite (103) zwischen zwei identischen Isolierplatten (100) gebildet ist, die nebeneinander angeordnet sind, wobei das Verfahren umfasst:
- Anordnen eines ersten Klebstoffs (702) zwischen der Wand und der Anbringungsseite (103),
wobei der Zwischenraum zwischen der Wand und der Grundschrift durch eine erste Ausnehmung (106) hervorgerufen wird, die sich über den gesamten Umfang der Isolierplatte (100) zwischen der zumindest einen Seitenwand (105) und der Anbringungsseite (103) erstreckt, und wobei das Verfahren ferner ein Anordnen eines zweiten Klebstoffs (703) in dem Zwischenraum neben der Anbringungsseite (103) umfasst, derart, dass die Isolierplatte (100) aufgrund des zweiten Klebstoffs (703) an der Wand (701) haftet,
dadurch gekennzeichnet, dass die erste Ausnehmung (106) durch Abschrägen der Kante der Isolierplatte auf der Anbringungsseite (103) gebildet wird.
11. Verfahren nach Anspruch 10, wobei zumindest eine der Seitenwände (105) eine zweite Ausnehmung (107) zur Aufnahme eines Dichtungstreifens umfasst und wobei ferner ein Dichtungstreifen (704) in der zweiten Ausnehmung (107) angeordnet wird.
12. Verfahren zum Einrichten einer Schalung für eine Gussstruktur (603) mit einer laminierten Isolierplatte (100), die eine Anbringungsseite (103), eine freie Seite (104) und eine Anzahl von Seitenwänden (105) aufweist, wobei zumindest eine Seitenwand (105) auf der Anbringungsseite (103) derart gebildet wird, dass im angebrachten Zustand ein oder mehrere Zwischenräume neben der Anbringungsseite (103) zwischen zwei Isolierplatten (100) hervorgerufen werden, die nebeneinander angeordnet sind, **dadurch gekennzeichnet, dass** das Verfahren die Schritte umfasst:
- Anordnen eines Dichtungsmittels (602) in dem einen Zwischenraum oder den mehreren Zwischenräumen neben der Anbringungsseite und Anordnen eines Verbindungsmittels (601) in der

zweiten Ausnehmung (107),
und dass die Isolierplatte (100) eine Grund-
schicht (101) aus einem Isoliermaterial und eine
Deckschicht (102) aus einem mechanisch stär-
keren Material umfasst.

Revendications

1. Panneau d'isolation stratifié (100) présentant une face de fixation (103) destinée à être placée contre une paroi (701), une face libre (104) et un certain nombre de parois latérales (105), comprenant une couche de base (101) en un matériau isolant et une couche de revêtement (102) en un matériau mécaniquement plus résistant, dans lequel au moins une paroi latérale (105), sur la face de fixation (103), est formée de telle sorte que, dans la situation positionnée, un espace adjacent à la face de fixation (103) est créé entre deux panneaux d'isolation identiques (100) agencés de manière adjacente l'un par rapport à l'autre, entre la paroi et ladite couche de base ; dans lequel ledit espace est créé par une première cavité (106) qui s'étend sur la totalité de la périphérie du panneau isolant (100), entre ladite au moins une paroi latérale (105) et la face de fixation (103) ; dans lequel ledit espace est adapté à l'utilisation d'un produit adhésif qui est sensiblement expansé après avoir été appliqué, **caractérisé en ce que** ladite première cavité (106) est formée par la réalisation d'un chanfrein sur le bord du panneau isolant, sur ladite face de fixation (103).
 2. Panneau d'isolation stratifié (100) selon la revendication 1, **caractérisé en ce qu'**au moins une partie de la face de fixation (103) présente une structure améliorant l'adhérence sur la paroi.
 3. Panneau d'isolation stratifié (100) selon l'une quelconque des revendications précédentes **caractérisé en ce qu'**au moins l'une des parois latérales (105) comprend une seconde cavité (107) destinée à recevoir une bande d'étanchéité, ladite seconde cavité (107) étant une rainure sensiblement parallèle à un bord de la face libre (104).
 4. Panneau d'isolation stratifié (100) selon la revendication 3, **caractérisé en ce que** ladite seconde cavité (107) s'étend sur la totalité de la périphérie du panneau d'isolation (100).
 5. Panneau d'isolation stratifié (100) selon l'une quelconque des revendications précédentes **caractérisé en ce que** la couche de revêtement (102) est principalement constituée par du béton.
 6. Panneau d'isolation stratifié (100) selon l'une quel-
- conque des revendications précédentes **caractérisé en ce que** la couche de base (101) est principalement constituée de plastique sous forme de mousse.
 7. Panneau d'isolation stratifié (100) selon la revendication 6, **caractérisé en ce que** ledit plastique sous forme de mousse comprend du polystyrène.
 8. Utilisation du panneau d'isolation stratifié (100) selon l'une quelconque des revendications 1 à 7 sous la forme d'une couche isolante sur une paroi verticale.
 9. Utilisation du panneau d'isolation stratifié (100) selon l'une quelconque des revendications 1 à 7 sous la forme de coffrage perdu afin d'ériger une structure coulée.
 10. Procédé d'agencement contre une paroi (701) d'un panneau d'isolation stratifié (100) avec une face de fixation (103), une face libre (104) et un certain nombre de parois latérales (105), lequel panneau d'isolation (100) comprend une couche de base (101) en un matériau isolant et une couche de revêtement (102) en un matériau mécaniquement plus résistant, dans lequel au moins une paroi latérale (105) sur la face de fixation (103) est formée de telle sorte que dans la situation positionnée, un espace adjacent à la face de fixation (103) est créé entre deux panneaux d'isolation identiques (100) agencés de manière adjacente l'un par rapport à l'autre, le procédé comprenant : l'agencement d'un premier adhésif (702) entre la paroi et la face de fixation (103) ; dans lequel ledit espace est créé entre la paroi et ladite couche de base, par une première cavité (106) qui s'étend sur la totalité de la périphérie du panneau d'isolation (100), entre ladite au moins une paroi latérale (105) et la face de fixation (103) ; et dans lequel, le procédé comprend en outre l'agencement d'un second adhésif (703) dans l'espace adjacent à la face de fixation (103) de telle sorte que le panneau d'isolation (100) adhère à ladite paroi (701) du fait dudit second adhésif (703), **caractérisé en ce que** ladite première cavité (106) est réalisée par formation d'un chanfrein sur le bord du panneau d'isolation sur ladite face de fixation (103).
 11. Procédé selon la revendication 10, dans lequel au moins l'une des parois latérales (105) comprend une seconde cavité (107) destinée à recevoir une bande d'étanchéité, comprenant en outre l'agencement d'une bande d'étanchéité (704) dans la seconde cavité (107).
 12. Procédé d'agencement d'un coffrage pour une structure coulée (603) avec un panneau d'isolation stratifié (100) comprenant une face de fixation (103), une

face libre (104) et un certain nombre de parois latérales (105), dans lequel au moins une paroi latérale (105) sur la face de fixation (103) est formée de telle sorte que, dans la situation positionnée, un ou plusieurs espaces adjacents à la face de fixation (103) sont créés entre deux panneaux d'isolation (100) agencés de manière adjacente l'un par rapport à l'autre,

caractérisé en ce que le procédé comprend les étapes de : agencement d'un moyen d'étanchéité (602) dans le ou les espaces adjacents à la face de fixation et agencement de moyens de liaison (601) dans la seconde cavité (107),

et **en ce que** ledit panneau isolant (100) comprend une couche de base (101) en un matériau isolant et une couche de revêtement (102) en un matériau mécaniquement plus résistant.

20

25

30

35

40

45

50

55

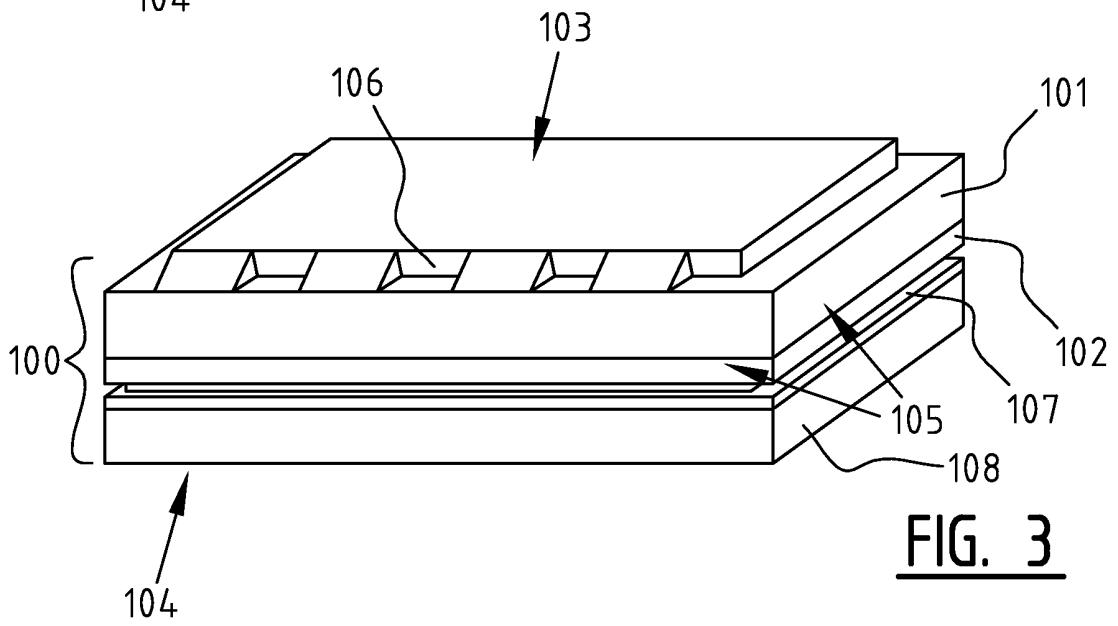
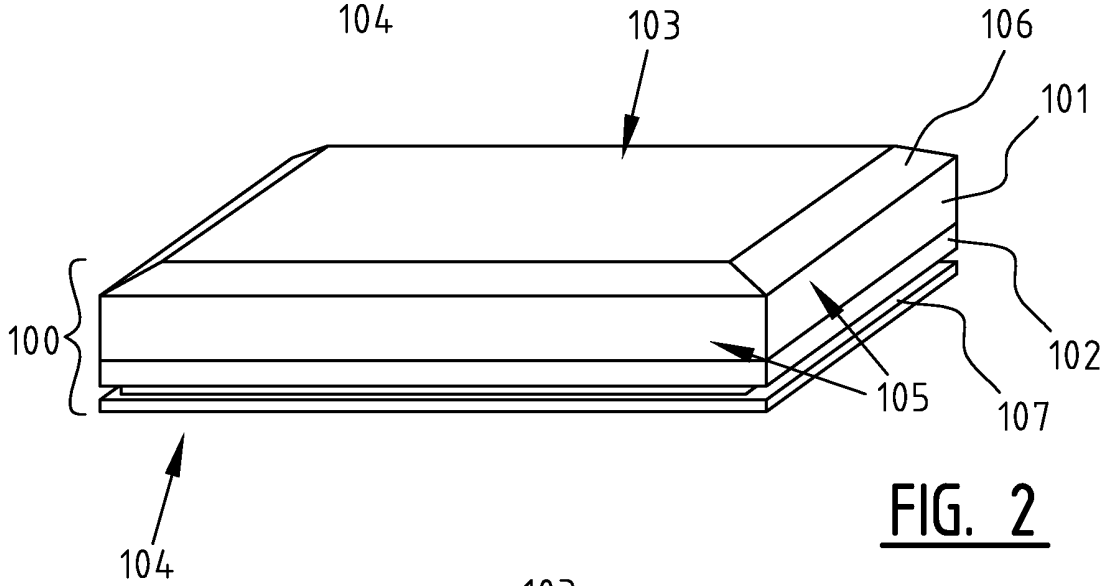
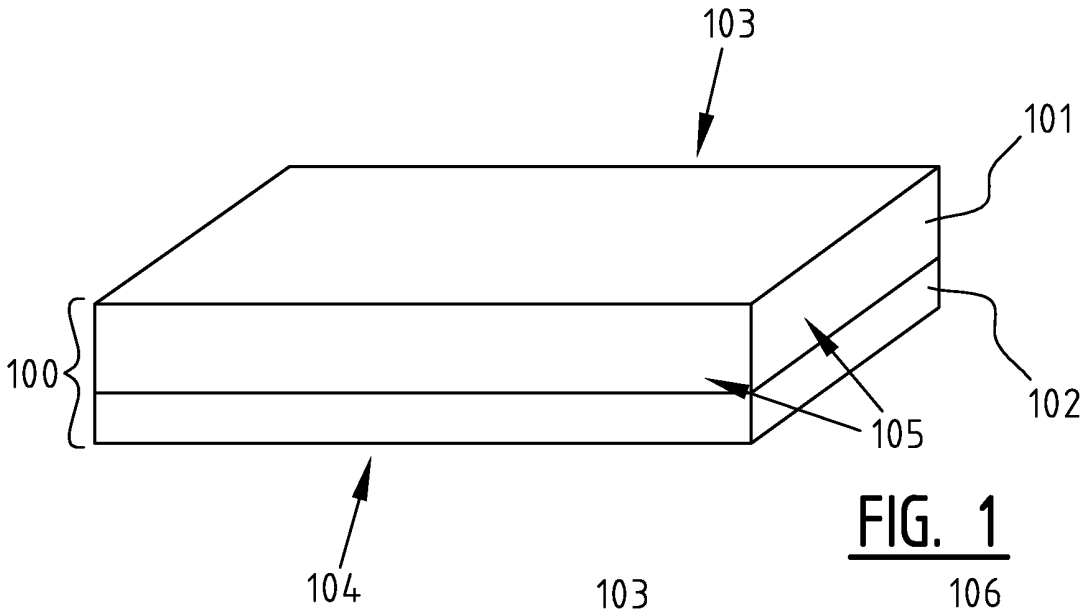

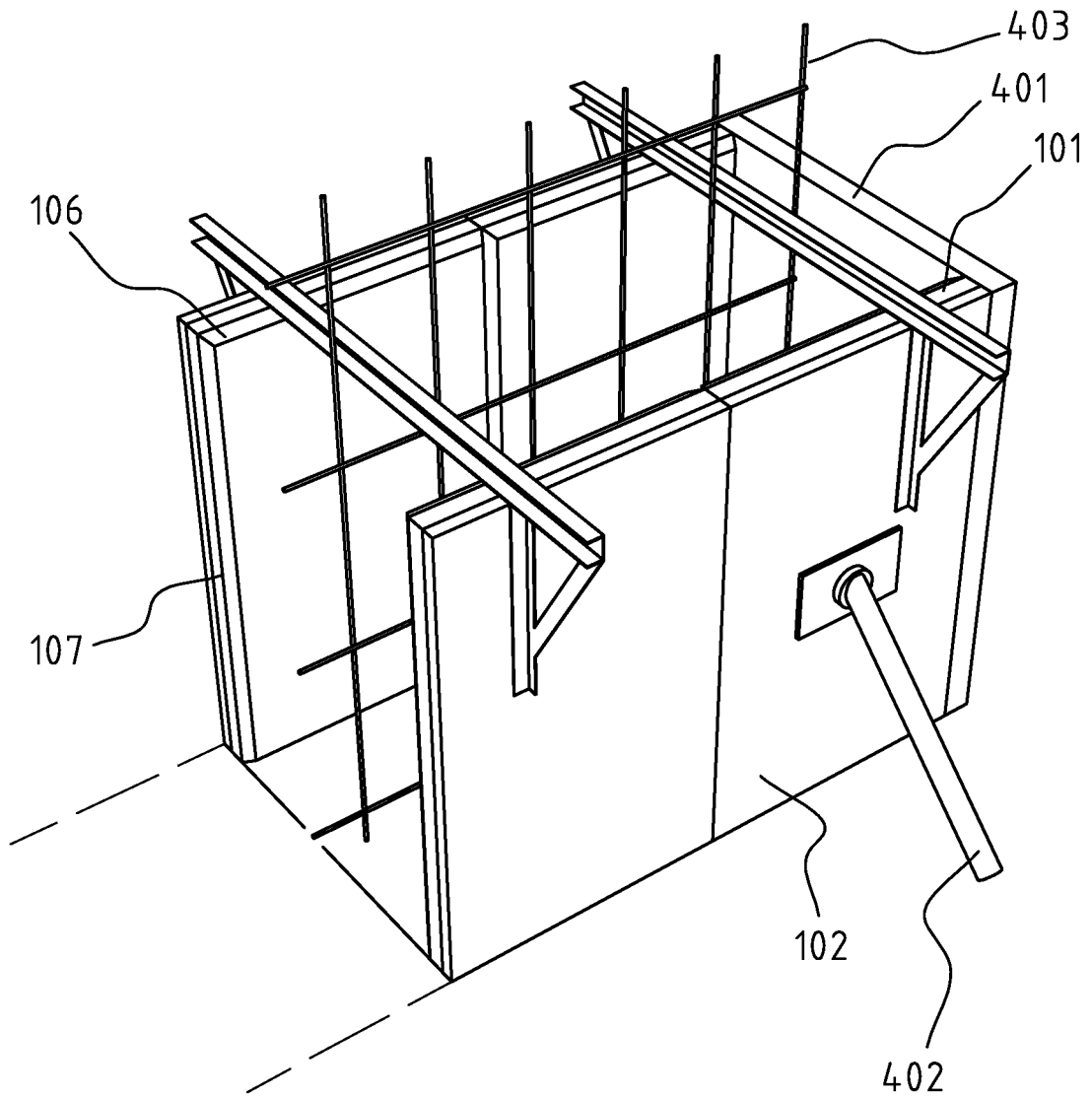

FIG. 4

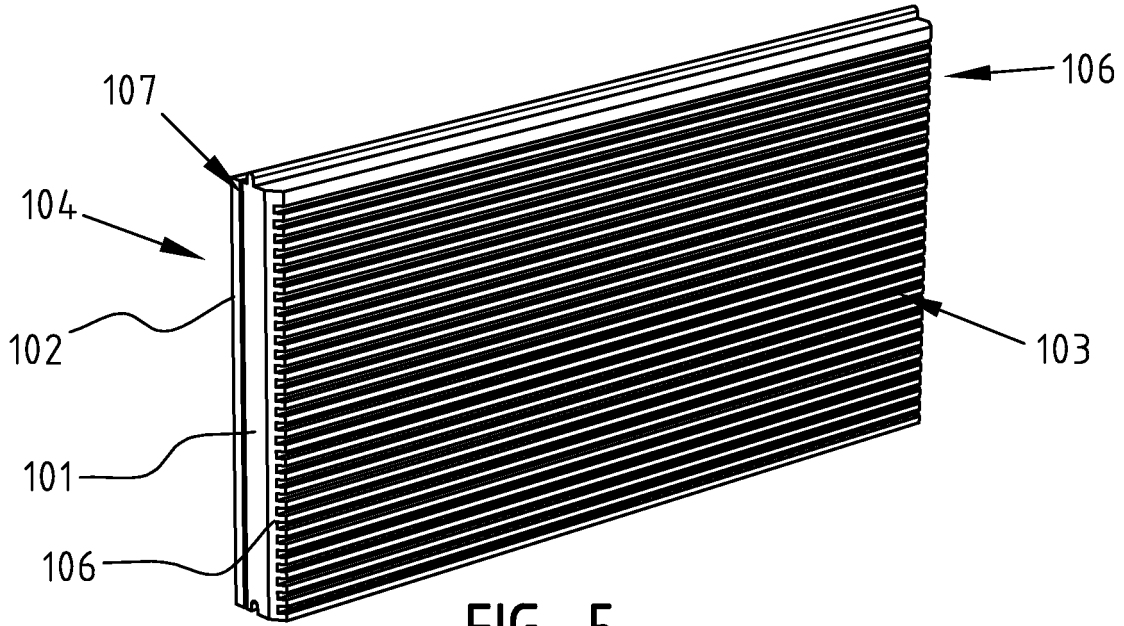

FIG. 5

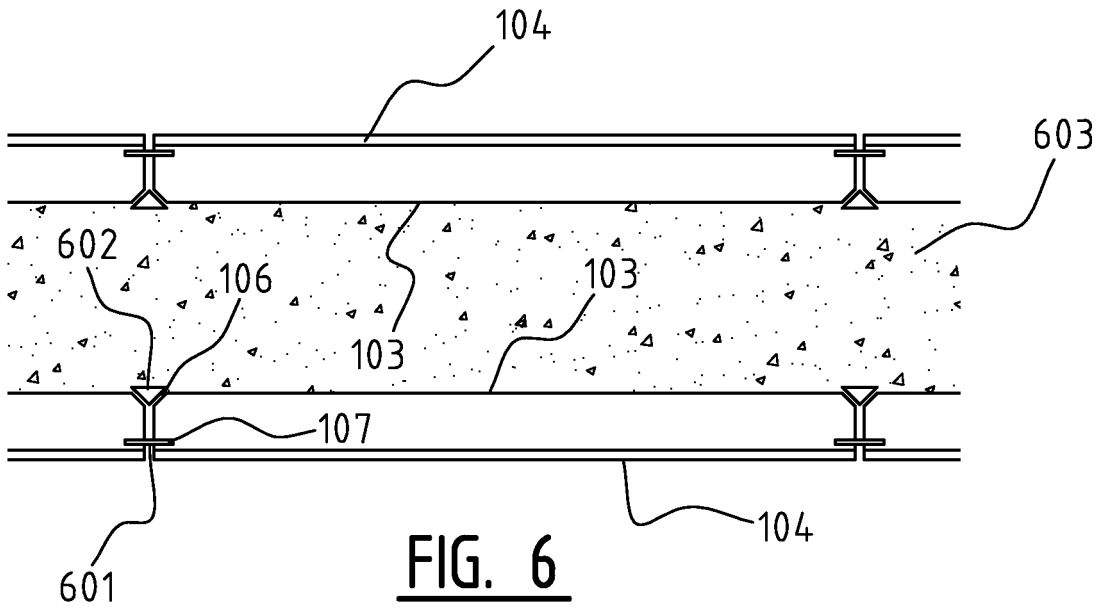

FIG. 6

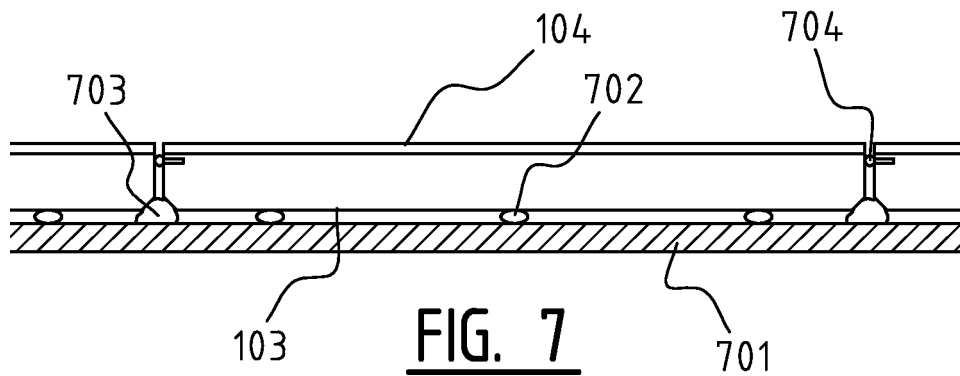

FIG. 7

REFERENCES CITED IN THE DESCRIPTION

This list of references cited by the applicant is for the reader's convenience only. It does not form part of the European patent document. Even though great care has been taken in compiling the references, errors or omissions cannot be excluded and the EPO disclaims all liability in this regard.

Patent documents cited in the description

- US 4587164 A [0003]
- FR 8014296 A [0005]
- EP 1640521 A [0007]
- CH 345140 [0012]
- US 4459334 A [0027]