

(19)



(11)

**EP 2 360 309 A1**

(12)

**EUROPEAN PATENT APPLICATION**

(43) Date of publication:  
**24.08.2011 Bulletin 2011/34**

(51) Int Cl.:  
**D06F 39/02** (2006.01) **D06F 39/04** (2006.01)  
**D06F 39/08** (2006.01) **D06F 33/02** (2006.01)

(21) Application number: **11153957.3**

(22) Date of filing: **10.02.2011**

(84) Designated Contracting States:  
**AL AT BE BG CH CY CZ DE DK EE ES FI FR GB GR HR HU IE IS IT LI LT LU LV MC MK MT NL NO PL PT RO RS SE SI SK SM TR**  
Designated Extension States:  
**BA ME**

(72) Inventors:  
• **Maeda, Kazunori**  
**Osaka-shi Osaka 540-6207 (JP)**  
• **Terai, Kenji**  
**Osaka-shi Osaka 540-6207 (JP)**  
• **Matsuoka, Shinji**  
**Osaka-shi Osaka 540-6207 (JP)**

(30) Priority: **17.02.2010 JP 2010032659**

(74) Representative: **Schwabe - Sandmair - Marx**  
**Patentanwälte**  
**Stuntzstraße 16**  
**81677 München (DE)**

(71) Applicant: **Panasonic Corporation**  
**Kadoma-shi**  
**Osaka 571-8501 (JP)**

(54) **Laundry machine and washing and drying machine**

(57) A laundry machine including: a housing (1); a water vessel (2) disposed in the housing (1); a detergent dispenser (10) provided above the water vessel (2); a water supply channel (17) in fluid communication with the detergent dispenser (10) and the water vessel (2); a

water supply valve (14) configured to control water supply; and a formation member (16) connected to the water supply valve (14) to form a water filling pipe (15) for supplying water on the detergent dispenser (10), wherein the water filling pipe (15) is disposed below the water supply valve (14).

**FIG.1**

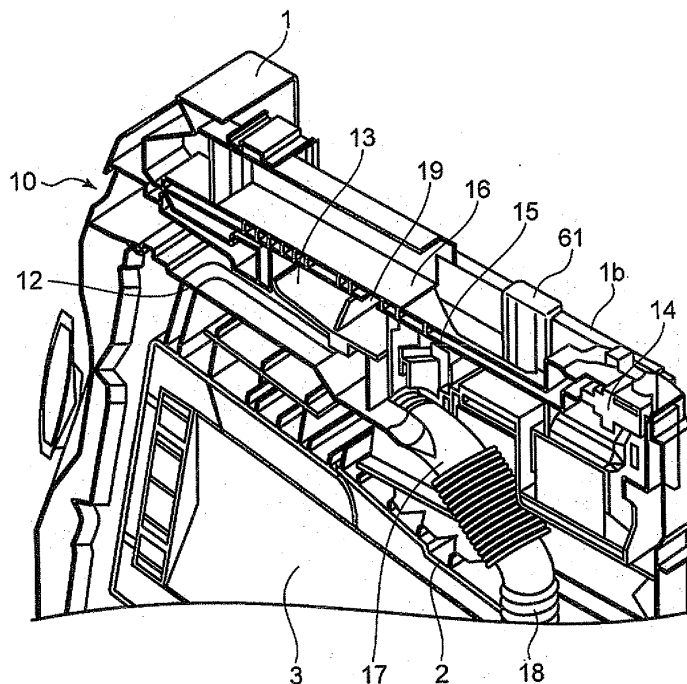

**EP 2 360 309 A1**

## Description

### Technical Field

**[0001]** The present invention relates to a laundry machine and a washing and drying machine including a detergent dispenser. The laundry machine which comprises a drying machine and which can work as a washing machine and/or a drying machine is called in the following "washing and drying machine".

### Background Art

**[0002]** A laundry machine (or a washing and drying machine) typically comprises a housing, a water vessel, and a water supply valve and a detergent case disposed in an upper portion of the housing. The water through the water supply valve passes through the detergent case configured to accommodate detergent and then is supplied to the water vessel. Consequently, the detergent is appropriately supplied into the water vessel (for example, refer to Japanese Patent Application Publication No. 2007-68801).

**[0003]** Fig. 17 shows a vertical cross section of a conventional drum-type laundry machine disclosed in Japanese Patent Application Publication No. 2007-68801. Fig. 18 is a side view of a detergent case of the laundry machine shown in Fig. 17.

**[0004]** As shown in Fig. 17, the laundry machine 160 comprises a drive motor 161, a drum 162 rotated by the drive motor 161, a water vessel (outer vessel) 163 accommodating the drum 162, and a detergent dispenser 164 disposed above the foregoing components. The drum 162 is used as a washing drum and a dewatering bin.

**[0005]** As shown in Fig. 18, the detergent dispenser 164 comprises a frame 165, a storage container 168 housed in the frame 165, and a cover 166 disposed above the storage container 168. A user may pull the storage container 168 from the frame 165 to put the detergent therein. A water filling pipe 166a is formed in the cover 166.

**[0006]** The laundry machine 160 further comprises a water supply hose 170. One end of the water supply hose 170 is connected to the water vessel 163 (refer to Fig. 17). The other end of the water supply hose 170 is connected to a bottom of the frame 165 (refer to Fig. 18).

**[0007]** The laundry machine 160 typically comprises a check valve 171 mounted on a joint between the frame 165 and the water supply hose 170. The check valve 171 allows water flow from the frame 165 to the water vessel 163 whereas the check valve 171 prevents water flow from the water vessel 163 to the frame 165.

**[0008]** The laundry machine 160 comprises an inlet 167 configured to connect to an external water source, and a water supply valve 169 mounted on a side of the frame 165. The water supply valve 169 stops the water flowing from the inlet 167 or allows the water supply to

the water vessel 163.

**[0009]** The frame 165 includes a connecting water channel 165a configured to allow the water flow from the water supply valve 169 to the water filling pipe 166a. As described above, the user may put the detergent in the storage container 168. The user may thereafter open the water supply valve 169 to supply water into the water filling pipe 166a via the connecting water channel 165a. The water supplied to the water filling pipe 166a flows into the storage container 168 from several water-filling holes (not shown) formed on the cover 166. The water and the detergent are mixed in the storage container 168 to become detergent mixed water. The detergent mixed water flows through the water supply hose 170 connected to the bottom of the frame 165, and then flows into the water vessel 163.

**[0010]** The housing 180 includes a top plate 180a, which forms a top surface of the housing 180. The detergent dispenser 164 is disposed in a space between the water vessel 163 and the top plate 180a of the housing 180. Such an arrangement of the detergent dispenser 164 contributes to downsizing of the laundry machine 160.

**[0011]** As described above, the water filling pipe 166a formed above the detergent dispenser 164 allows water to be poured from above the storage container 168. The water filling pipe 166a is adjacent to an inner surface (lower surface) of the top plate 180a of the housing 180. The inlet 167 is formed at the top plate 180a of the housing 180 as described above. The inlet 167 is connected to a water source such as a water faucet with a pipeline such as a hose. The water supply valve 169 inside the housing 180 is disposed below the inlet 167.

**[0012]** Fig. 19 shows a schematic cross section of elements disposed in an upper portion of the laundry machine 160. The laundry machine 160 is described in further detail with reference to Figs. 18 and 19.

**[0013]** Figs. 18 and 19 show a relative positional relationship between the water filling pipe 166a and the water supply valve 169. The water supply valve 169 is mounted more inward (downward) in the housing 180. Accordingly, the water filling pipe 166a near the inner surface of the top plate 180a of the housing 180 is positioned above the water supply valve 169. Consequently, when the water supply valve 169 is closed after the water supply process is complete (that is, after the operation of the laundry machine 160 is ended), as shown in Fig. 19, it is likely that water remains in the connecting water channel 165a configured to connect the water supply valve 169 to the water filling pipe 166a. It may be more humid around the water supply valve 169, the connecting water channel 165a and the water filling pipe 166a because of the water remaining in the connecting water channel 165a. Accordingly, if the water remaining in the connecting water channel 165a is kept unattended, it is likely that mold grows around the water supply valve 169, the connecting water channel 165a and the water filling pipe 166a. Due to the growth of the mold and other contamination around the

water supply channel for guiding water to the water vessel 163, it is less likely that clothing is washed with clean water. The washing performance of the laundry machine 160 may thereby deteriorate.

#### Summary of the Invention

**[0014]** An object of the present invention is to provide a laundry machine and a washing and drying machine configured to effectively reduce growth of mold around a water supply valve and maintain washing performance.

**[0015]** A laundry machine according to one aspect of the present invention includes: a housing; a water vessel disposed in the housing; a detergent dispenser provided above the water vessel; a water supply channel in fluid communication with the detergent dispenser and the water vessel; a water supply valve configured to control water supply; and a formation member connected to the water supply valve to form a water filling pipe configured to supply water into the detergent dispenser, wherein the water filling pipe is disposed below the water supply valve.

**[0016]** A washing and drying machine according to one aspect of the present invention includes: the foregoing laundry machine; a rotatable drum internally mounted in the water vessel; and a drying mechanism configured to supply drying air into the drum for drying clothing in the drum.

#### Brief Description of the Drawings

##### [0017]

Fig. 1 is a perspective cross sectional view schematically showing elements disposed in an upper portion of a drum-type washing and drying machine according to one embodiment.

Fig. 2 is a lateral cross sectional view schematically showing the elements of the washing and drying machine shown in Fig. 1.

Fig. 3 is a perspective view showing the cross section of the elements of the washing and drying machine shown in Fig. 1.

Fig. 4 is a plan view of the elements of the washing and drying machine shown in Fig. 1.

Fig. 5 is a vertical cross sectional view along a line A-A shown in Fig. 4.

Fig. 6 is a plan view of the elements of the washing and drying machine shown in Fig. 1.

Fig. 7 is a perspective view showing the elements disposed in the internal upper space of the housing of the washing and drying machine shown in Fig. 1.

Fig. 8 is a perspective view showing the elements disposed in the internal upper space of the housing of the washing and drying machine shown in Fig. 1.

Fig. 9 is a perspective view showing a support mechanism configured to support a heat pump device used for drying clothing in the washing and drying

machine shown in Fig. 1.

Fig. 10 is a perspective view showing the elements of the washing and drying machine shown in Fig. 1.

Fig. 11 is a perspective view showing another support mechanism configured to support the heat pump device used for drying clothing in the washing and drying machine shown in Fig. 1.

Fig. 12 is a perspective view showing the elements of the heat pump device used for drying clothing in the washing and drying machine shown in Fig. 1.

Fig. 13 is a perspective view schematically showing the washing and drying machine configured to dry clothing using a heat pump device according to one embodiment.

Fig. 14 is a partial perspective view showing a front surface of the washing and drying machine shown in Fig. 1.

Fig. 15 is a cross sectional view schematically showing the elements disposed in the upper portion of the washing and drying machine shown in Fig. 1.

Fig. 16 is a cross section schematically showing the elements disposed in the upper portion of the washing and drying machine shown in Fig. 1.

Fig. 17 is a vertical cross sectional view of a conventional drum-type laundry machine.

Fig. 18 is a side view showing a configuration of a detergent case of the laundry machine shown in Fig. 17.

Fig. 19 is a cross sectional view schematically showing elements in an upper portion of the laundry machine shown in Fig. 17.

#### Description of the Preferred Embodiments

**[0018]** A laundry machine according to one embodiment is now described with reference to the accompanying drawings. In this embodiment, a drum-type washing and drying machine is exemplified as a washing and drying machine. Alternatively, the washing and drying machine may also be different types of washing and drying machines. Moreover, a washing device without a drying function may also be used as a laundry machine. Accordingly, the detailed structure described below does not in any way limit a principle according to this embodiment.

(Entire Configuration of Drum-type Washing and Drying Machine)

**[0019]** Fig. 2 shows a schematic lateral cross section of the drum-type washing and drying machine according to one embodiment. An overall configuration of the washing and drying machine is now described with reference to Fig. 2.

**[0020]** The washing and drying machine 500 comprises a housing 1 including walls configured to define an internal space for accommodating various elements used for washing and drying clothing. The walls of the

housing 1 include a front wall 1e disposed on the front side and a rear wall 1d opposite to the front wall 1e.

**[0021]** The washing and drying machine 500 further comprises a cylindrical drum 3 disposed in the housing 1. The drum 3 includes a peripheral wall 531 defining an opening, which opens toward the front wall 1e, and a bottom wall 532 opposite to the opening defined by the peripheral wall 531. Clothing is placed in the drum 3 through the opening, which is opened toward the front wall 1e.

**[0022]** The washing and drying machine 500 comprises a cylindrical water vessel 2 disposed in the housing 1. The water vessel 2 accommodating the drum 3 includes a peripheral wall 521 surrounding the peripheral wall 531 of the drum 3, and a bottom wall 522 along the bottom wall 532 of the drum 3. Wash water is stored in the water vessel 2.

**[0023]** The washing and drying machine 500 comprises a drive motor 7 mounted on the bottom wall 522 of the water vessel 2. The rotational axis of the drum 3, which is rotated with the drive motor 7, is upwardly tilted toward the front wall 1e. A water supply pipe (not shown) provided with a water supply valve (not shown) and a drainage pipe provided with a drain valve (not shown) may be connected to the water vessel 2.

**[0024]** An exhaust outlet 11 is formed in an upper portion of the peripheral wall 531 of the drum 3. Dry air after drying the clothing in the drum 3 is efficiently exhausted from the drum 3 through the exhaust outlet 11. Alternatively, the exhaust outlet 11 may also be formed at any other portion than the upper portion of the peripheral wall 531 of the drum 3. The exhaust outlet 11 is preferably formed above a water level of the wash water in the drum 3, so that it is less likely that the wash water in the drum 3 affects the exhaust of the dry air from the drum 3.

**[0025]** The washing and drying machine 500 comprises a damper (not shown) disposed below the water vessel 2. The damper supports the water vessel 2. For example, while the clothing is dewatered, the clothing may be unevenly distributed in the drum 3. The uneven distribution of clothing in the drum 3 may result in unbalanced weight of the drum 3, which in turn causes vibration of the water vessel 2. The damper appropriately attenuates the vibration of the water vessel 2.

**[0026]** Fig. 14 is a schematic perspective front view of the washing and drying machine 500. The washing and drying machine 500 is now described in further detail with reference to Figs. 2 and 14.

**[0027]** The washing and drying machine 500 comprises a door 5. The rotatable door 5 is mounted to the front wall 1e of the housing 1. The door 5 is turned between an open position (refer to Fig. 14) in which the door 5 protrudes from the front wall 1e of the housing 1 and a closed position (refer to Fig. 2) in which the door 5 confronts the opening of the drum 3. The user may turn the door 5 toward the open position to place laundry (clothing) into the drum 3 or remove laundry (clothing) from the drum 3.

**[0028]** The washing and drying machine 500 comprises an operation panel 4 mounted in an upper portion of the front wall 1e of the housing 1. The horizontally extending operation panel 4 includes various operation keys and a display.

**[0029]** The housing 1 includes a right wall 1a disposed between the front wall 1e and the rear wall 1d, and a left wall 1b opposite to the right wall 1a. The washing and drying machine 500 comprises a detergent dispenser 10 mounted on the front wall 1e. The detergent dispenser 10 below the operation panel 4 is disposed near a corner between the front wall 1e and the left wall 1b. The user may draw out the detergent dispenser 10 from the housing 1.

(Elements for Water Supply)

**[0030]** Fig. 1 is a schematic perspective view showing elements configured to supply water into the water vessel 2. Fig. 6 is a plan view of the elements in an upper portion of the housing 1. Fig. 7 is a perspective view of the elements shown in Fig. 6. Fig. 10 is a schematic perspective view of the washing and drying machine 500. The elements configured to supply water into the water vessel 2 are now described with reference to Figs. 1, 2, 6, 7 and 10.

**[0031]** As shown in Figs. 6, 7 and 10, the washing and drying machine 500 further comprises an inlet 20 to which a water channel such as hose extending from a water source (e.g. water faucet) is attached. As shown in Figs. 6 and 10, the inlet 20 is disposed beside the rear wall 1d of the housing 1.

**[0032]** As shown in Figs. 1 and 6, the washing and drying machine 500 comprises a water supply valve 14 below the inlet 20. The water supply valve 14 connected to the inlet 20 in the housing 1 controls water supply (stops or allows water flow from the inlet 20).

**[0033]** As shown in Fig. 2, the walls of the housing 1 include an upper wall 1c surrounded by the upper edges of the front wall 1e, the rear wall 1d, the right wall 1a and the left wall 1b. The upper wall 1c forms a top surface of the housing 1. As shown in Fig. 1, the aforementioned detergent dispenser 10 is disposed between the upper wall 1c of the housing 1 and the water vessel 2. The detergent dispenser 10 comprises a frame 12 and a storage container 13 accommodated in the frame 12. The user may draw out the storage container 13 from the frame 12 to put the detergent in the storage container 13.

**[0034]** The storage container 13 is a substantially rectangular box which opens upward. The storage container 13 may be partitioned, for example, into a first storage room configured to store powder detergent, a second storage room configured to store liquid detergent and a third storage room configured to store liquid softener. Alternatively, the storage container 13 may have any other structure to store any detergent.

**[0035]** The washing and drying machine 500 comprises a formation member 16 above the detergent dispenser

10. The formation member 16 forms a water filling pipe 15. The water filling pipe 15 is connected to the water supply valve 14. Water from the water supply valve 14 passes through the water filling pipe 15 and is supplied to the storage container 13. In this embodiment, the formation member 16 forms the water filling pipe 15 below the water supply valve 14. Consequently, when the water supply is complete, the water around the water supply valve 14 is appropriately drained, and it is less likely that the water remains around the water supply valve 14.

**[0036]** The formation member 16 is manufactured by thermally bonding two resin sheets molded from a resin material such as polypropylene resin. The water filling pipe 15 is formed inside the formation member 16. The water filling pipe 15 may include, for example, a first water filling pipe configured to guide water to the aforementioned first storage room and the second storage room, and a second water filling pipe configured to guide water to the aforementioned third storage room. Preferably, the washing and drying machine 500 comprises two water supply valves 14. One water supply valve 14 is mounted on the first water filling pipe and the other water supply valve 14 is mounted on the second water filling pipe. In the washing process for washing the clothing, the water supply valve 14 mounted on the first water filling pipe may be opened, and the water supply valve 14 mounted on the second water filling pipe may be closed. Consequently, in the washing process, water is appropriately supplied to the first storage room and the second storage room in which the detergent is stored. In the rinsing process for rinsing the clothing, the water supply valve 14 mounted on the first water filling pipe may be closed and the water supply valve 14 mounted on the second water filling pipe may be opened. Consequently, in the rinsing process, water is appropriately supplied to the third storage room in which the liquid softener is stored.

**[0037]** In this embodiment, the formation member 16 is formed from polypropylene resin. Alternatively, the formation member 16 may also be formed from other materials. Preferably, easily-worked materials may be used for the formation member 16.

**[0038]** In this embodiment, the formation member 16 defines two water filling pipes. Alternatively, the formation member may form other water pouring structures. Preferably, a shape or a structure of the formation member 16 is designed to match a structure of the storage container 13.

**[0039]** The formation member 16 includes a bottom surface formed with several water-filling holes 19. The water supplied from the water supply valve 14 flows through the water filling pipe 15, thereafter passes through the water-filling holes 19, and flows into the storage container 13. The storage container 13 stores the detergent as described above. The detergent and water are mixed in the storage container 13. The mixed liquid of the detergent and the water is subsequently moved to the frame 12.

**[0040]** The washing and drying machine 500 further

comprises a water supply hose 17. One end of the water supply hose 17 is connected to a bottom of the frame 12. The other end of the water supply hose 17 is connected to the water vessel 2. A water supply channel is thereby formed between the frame 12 and the water vessel 2. The mixed liquid of the detergent and the water after the movement to the frame 12 flows into the water vessel 2 through the water supply hose 17.

**[0041]** The washing and drying machine 500 further comprises a check valve 18 disposed at a connection between the water vessel 2 and the water supply hose 17 (water supply channel). The check valve 18 allows the water to flow from the detergent dispenser 10 to the water vessel 2 (water flow in a forward direction) whereas the check valve 18 prevents the flow of the water (as well as air) from the water vessel 2 to the detergent dispenser 10 (flow in a reverse direction). The check valve 18 prevents, for example, in the washing process, flow of wash water in the water vessel 2 toward the detergent dispenser 10. Moreover, the check valve 18 prevents, for example, in the drying process, leakage of dry air for drying the clothing from the water vessel 2 through the water supply hose 17.

**[0042]** As shown in Figs. 7 and 10, the washing and drying machine 500 further comprises a control substrate 50 in the housing 1. The control substrate 50 above the detergent dispenser 10 comprises various electronic elements (various circuits) which are used to control the washing and drying machine 500.

**[0043]** A control substrate of a general washing and drying machine is disposed in a lower portion of the housing, but in this embodiment, the control substrate 50 is disposed in an upper portion of the housing 1. Accordingly, lead wires used for electrical connection among various elements controlled by the control substrate 50 may become shorter.

**[0044]** As shown in Fig. 10, the control substrate 50 is disposed near the front wall 1e of the housing 1. Accordingly, an electrician repairing the control substrate 50 may easily access the control substrate 50 in the upper portion of the housing 1 and near the front wall 1e. The electrician with standing near the front wall 1e may repair the control substrate 50, which results in more efficient maintenance work for the control substrate 50.

(Operation of Washing and Drying Machine in Washing Process)

**[0045]** The operation of the washing and drying machine 500 in the washing process is now described with reference to Figs. 1, 2, 6, 7, 10 and 19. In the washing process, the washing and drying machine 500 performs the washing process, rinsing process and dewatering process.

**[0046]** The washing and drying machine 500 measures weight of the laundry placed in the drum 3 when the washing process starts. The washing and drying machine 500 displays, on the display of the operation panel 4,

rough amounts of the detergent and the liquid softener, which are required for washing the laundry based on the measured weight.

**[0047]** The user may draw the storage container 13 out from the front wall 1e of the housing 1 to put the displayed amounts of the detergent (the powder detergent and/or the liquid detergent) and the liquid softener in the storage container 13. The user may select any types of the detergent and the liquid softener. Accordingly, the user may put either the powder detergent or the liquid detergent in the storage container 13, or put both the powder detergent and the liquid detergent in the storage container 13.

**[0048]** The washing and drying machine 500 thereafter opens the water supply valve 14 (for the first storage room and/or second storage room) to start the water supply. The water reaches the water filling pipe 15 through the water supply valve 14. Subsequently, the water flows into the storage container 13 through the water-filling holes 19. The water and the detergent are mixed in the storage container 13 to be detergent mixed water. The detergent mixed water flows into the frame 12 from the storage container 13. Eventually, the detergent mixed water flows into the water vessel 2 through the water supply hose 17 (water supply channel). It should be noted that the washing and drying machine 500 controls the water supply valve 14 according to the measured laundry weight to supply an appropriate amount of detergent mixed water to the water vessel 2.

**[0049]** When the appropriate amount of the detergent mixed water is supplied to the water vessel 2, the washing and drying machine 500 closes the water supply valve 14. The washing and drying machine 500 thereafter rotates the drum 3 to execute the washing process.

**[0050]** After the washing process is performed for a given period, the rinsing process is executed. The washing and drying machine 500 opens the water supply valve 14 (for the third storage room) in the rinsing process to make mixed liquid of water and the liquid softener in the storage container 13. The mixed liquid of the water and the liquid softener is supplied to the water vessel 2.

**[0051]** As described in the context of Fig. 19, after washing process ends, it is likely that water remains around the water supply valve of the conventional washing and drying machine whereas since the washing and drying machine 500 according to this embodiment comprises the water filling pipe 15 below the water supply valve 14, water around the water supply valve 14 is drained through the water filling pipe 15. Since there is little or no water around the water supply valve 14, it is less likely that mold grows around the water supply valve 14. Consequently, unlike the conventional washing and drying machine, the washing and drying machine 500 according to this embodiment may supply cleaner water to the water vessel 2 through the water supply valve 14 and maintain excellent washing performance for a long time.

**[0052]** Since the water filling pipe 15 is disposed below

the water supply valve 14, the detergent dispenser 10 is also disposed at a lower position in comparison to a conventional washing and drying machine. Consequently, a space is created between the detergent dispenser 10 and the upper wall 1c of the housing 1. This space is used for installation of the control substrate 50. Since the internal space of the housing 1 is exploited, the washing and drying machine 500 according to this embodiment may be designed to have an equivalent size to the conventional washing and drying machine.

(Location of Check Valve)

**[0053]** The check valve 18 is now described with reference to Figs. 1 and 18.

**[0054]** As shown in Fig. 18, the check valve 171 of the conventional washing and drying machine is mounted near the detergent dispenser 164 (on a connection between the frame 165 and the water supply hose 170). Specifically, the check valve 171 is disposed at a discharge opening of the detergent dispenser 164. The arrangement of the conventional check valve 171 requires higher hydraulic head pressure in order for water (detergent mixed water) in the detergent dispenser 164 to pass through the check valve 171. In order to obtain the higher hydraulic head pressure, the conventional detergent dispenser 164 needs to be designed to have a larger height.

**[0055]** As shown in Fig. 1, the check valve 18 of the washing and drying machine 500 according to this embodiment is mounted near the water vessel 2 (on a connection between the water vessel 2 and the water supply hose 17). Specifically, the check valve 18 is disposed near the water vessel 2 and not near the discharge opening of the detergent dispenser 10. Since sufficient hydraulic head pressure is obtained between the check valve 18 and the detergent dispenser 10 for passing the water through the check valve 18, the flow of the water (detergent mixed water) from the detergent dispenser 10 toward the water vessel 2 may be achieved even if the detergent dispenser 10 with a smaller height than the conventional detergent dispenser 164 is used.

**[0056]** In this embodiment, since the compact detergent dispenser 10 with the smaller height is used, the washing and drying machine 500 may also be downsized. In addition, the reduction in the height of the detergent dispenser 10 also contributes to creating a space for installing the control substrate 50 and other elements (space between the upper wall 1c of the housing 1 and the detergent dispenser 10), which results in more free design of the washing and drying machine 500.

(Control substrate)

**[0057]** Figs. 15 and 16 show schematic cross sections of the control substrate 50. The control substrate 50 is now described with reference to Figs. 15 and 16.

**[0058]** The control substrate 50 comprises a heat sink 50a (radiator). The heat sink 50a radiates heat generated

from the various electronic elements and circuits of the control substrate 50 to reduce temperature of the control substrate 50.

**[0059]** As shown in Fig. 15, the heat sink 50a of the control substrate 50 is disposed near the formation member 16 configured to form the water filling pipe 15. Preferably, the heat sink 50a of the control substrate 50 is in contact with the formation member 16.

**[0060]** The formation member 16 is cooled by the water flowing through the water filling pipe 15. Accordingly, efficient radiation of heat from the control substrate 50 to the formation member 16 is achieved with the heat sink 50a of the control substrate 50 near or in contact with the formation member 16. Therefore, it is less likely that heat accumulation in the control substrate 50 causes any malfunction.

**[0061]** As shown in Fig. 16, a through-hole 16a may also be formed in the formation member 16. The heat sink 50a of the control substrate 50 in contact with the formation member 16 covers the through-hole 16a. Since the water passing through the water filling pipe 15 directly contacts the heat sink 50a, more efficient heat radiation from the control substrate 50 to the formation member 16 is achieved. Preferably, a sealing member is disposed between the formation member 16 and the heat sink 50a. The sealing member seals a boundary between the formation member 16 and the heat sink 50a to inhibit water leakage from the through-hole 16a.

(Heat pump device)

**[0062]** The washing and drying machine 500 has, in addition to the washing function for washing clothing, a drying function for drying the clothing. The clothing is dried with a heat pump device.

**[0063]** Fig. 4 is a schematic plan view of the washing and drying machine 500. Fig. 5 is a cross sectional view along a line A-A shown in Fig. 4. Fig. 6 is a perspective view schematically showing an upper configuration of the washing and drying machine 500. Fig. 13 is a schematic perspective view of the washing and drying machine 500. The heat pump device is now described with reference to Figs. 1 to 6 and Fig. 13.

**[0064]** The washing and drying machine 500 includes a heat pump device 30, and various elements connected to the heat pump device 30 and circulating the dry air for drying the clothing. The heat pump device 30 and the various elements which work with the heat pump device 30 and define a circulation path of the dry air are intensively disposed in the upper space (space above the water vessel 2) of the housing 1.

**[0065]** The heat pump device 30 and the various elements which work with the heat pump device 30 and define the circulation path of the dry air are heavier. As shown in Figs. 2 and 13, the heat pump device 30 and the various elements which work with the heat pump device 30 and define the circulation path of the dry air are disposed in the upper space of the housing 1. The wash-

ing and drying machine 500 comprises a support structure configured to support the heat pump device 30 and the various elements which work with the heat pump device 30 and define the circulation path of the dry air. The support structure protects the aforementioned elements from an impact which may happen during transportation of the washing and drying machine 500 or arise from dropping off of the washing and drying machine 500.

**[0066]** As shown in Figs. 3 to 5, the heat pump device 30 comprises a compressor 31 configured to compress refrigerant, a heat exchanger 80 configured to dry the clothing in the drum 3, and a decompressor 33 including an expansion valve (or capillary tube) configured to decompress the highly pressurized refrigerant. The heat exchanger 80 comprises a heating portion 32 configured to radiate heat of the highly pressurized and heated refrigerant due to compression by the compressor 31, and a dehumidifier 34 configured to remove ambient heat with the decompressed refrigerant with lower pressure.

**[0067]** As shown in Fig. 3, the heat pump device 30 further comprises a tube 39 connecting the compressor 31, the heating portion 32, which configure the heat exchanger 80, the dehumidifier 34 and the decompressor 33. The refrigerant flowing through the tube 39 is circulated among the compressor 31, the heating portion 32, the dehumidifier 34 and the decompressor 33.

**[0068]** Fig. 3 shows a generatrix G extending from an apex 2a (the uppermost point of the discoid bottom wall 522) of the bottom wall 522 of the water vessel 2. The generatrix G is the uppermost generatrix representing an outer surface of the peripheral wall 521 of the water vessel 2.

**[0069]** The compressor 31 above the peripheral wall 521 of the water vessel 2 is shifted toward the right wall 1a rather than the generatrix G. The compressor 31 includes a bottom surface 31a positioned below the generatrix G. Since the upper space above the peripheral wall 521 of the water vessel 2 is exploited for installation of the compressor 31, the heat pump device 30 including the compressor 31 may be appropriately accommodated in the smaller housing 1. Since a position of the compressor 31 is shifted toward the right wall 1a (or left wall 1b) rather than the uppermost generatrix G, the heat pump device 30 may be located in the upper space without increase in height of the housing 1. The compact washing and drying machine 500 may thereby be provided.

**[0070]** The refrigerant flowing through the tube 39 in the dehumidifier 34 exchanges heat with ambient air (dry air flowing from the filter 40 to the dehumidifier 34). Consequently, the refrigerant is heated and vaporized whereas water components in the dry air become condensed, which result in removal of the water components from the dry air.

**[0071]** The vaporized refrigerant flows into the compressor 31. The compressor 31 compresses the refrigerant, which becomes highly heated and pressurized. The highly heated and pressurized refrigerant thereafter flows into the heating portion 32. In the heating portion

32, the refrigerant exchanges heat with the ambient air (dry air flowing from the dehumidifier 34 to the heating portion 32). Consequently, the dry air is heated whereas the refrigerant is cooled and liquefied.

**[0072]** The decompressor 33 decompresses the liquefied and pressurized refrigerant, which becomes cooler and lower pressure. The cooler refrigerant with lower pressure flows into the dehumidifier 34 once again.

**[0073]** The blower 9 blows the dry air toward the water vessel 2. The dry air thereafter flows into the drum 3 through the water vessel 2, so that the clothing stored in the drum 3 is dried.

**[0074]** As a result of drying the clothing, the dry air contains a larger amount of water components. As described above, the blower 9 sucks the dry air in the drum 3 from the exhaust outlet 11 of the water vessel 2, so that the dry air reaches the heat pump device 30 via the filter 40.

**[0075]** As described above, the dehumidifier 34 of the heat pump device 30 initially dehumidifies and cools the dry air. Consequently, the water components in the dry air become condensed and are separated from the dry air. The dry air thereafter flows into the heating portion 32, which heats the dry air as described above. Consequently, the dry air passing through the heat pump device 30 becomes heated and less humid. The blower 9 re-sends the heated and less humid air to the drum 3.

**[0076]** As shown in Figs. 4 and 6, the washing and drying machine 500 comprises a fastening member 38 configured to fasten the blower 9 to the heat pump device 30. The blower 9 fastened to the heat pump device 30 with the fastening member 38 is disposed beside the compressor 31. Since the space formed beside the compressor 31 in the housing 1 is exploited for installation of the blower 9, the blower 9 is appropriately accommodated in the housing 1 without unnecessary enlargement of the housing 1. Since the washing and drying machine 500 does not become unnecessarily taller even if the heat pump device 30 and the blower 9 are disposed in the upper space in the housing 1, the compact washing and drying machine 500 is provided.

(Filter)

**[0077]** The filter is now described with reference to Figs. 2, 5, 6 and 14.

**[0078]** As shown in Figs. 5 and 6, the washing and drying machine 500 comprises the filter 40 disposed at an upstream position of the heat exchanger 80. The filter 40 defines the circulatory airflow path 8 together with the heat pump device 30. When the washing and drying machine 500 performs the drying process, lint (dust components separated from the clothing) gets mixed into the dry air. Since the filter 40 provided in the circulatory airflow path 8 removes the lint from the dry air immediately before the heat exchanger 80, it is likely that the filter 40 moderates accumulation of the lint, which may cause deterioration in heat exchange efficiency of the heat ex-

changer 80.

**[0079]** As shown in Fig. 5, the filter 40 includes a first filter 40A and a second filter 40B disposed at a downstream position of the first filter 40A. The first filter 40A is coarser than the second filter 40B. Accordingly, the second filter 40B traps and collects finer lint and other foreign objects passed through the first filter 40A. Consequently, it is less likely that the lint and other foreign objects adhere, which results in less deterioration of efficiencies in the heat exchange of the heat pump device 30 and air circulation of the blower 9. Moreover, it is less likely that the lint and other foreign objects scatter outside the housing 1 because of the filter 40, which results in less contamination around the washing and drying machine 500.

**[0080]** As shown in Fig. 14, an opening 40c is formed on the upper wall 1c of the housing 1. The first filter 40A is attached to and removed from the circulatory airflow path 8 through the opening 40c near a front edge of the upper wall 1c. Accordingly, the user or the worker with standing near the front wall 1e of the housing 1 may attach or remove the first filter 40A to or from the housing 1, which results in more efficient maintenance for the washing and drying machine 500.

**[0081]** As shown in Fig. 5, unlike the first filter 40A, the second filter 40B is fixed to the circulatory airflow path 8. Since the first filter 40A removes the lint and other foreign matters from the dry air before the second filter 40B, the second filter 40B less frequently clogs. Moreover, the user or the worker may clean the second filter 40B through the opening 40c formed on the upper wall 1c of the housing 1. Accordingly, it is not so big deal to eliminate the clogging of the second filter 40B fixed to the circulatory airflow path 8.

**[0082]** The heat exchanger 80 is disposed immediately after the second filter 40B. As described above, the refrigerant heated by the compressor 31 flows in the heat exchanger 80. The second filter 40B fixed to the circulatory airflow path 8 prevents a poorly experienced user for maintenance work from easy access to the heat exchanger 80. In addition, unlike the first filter 40A, since the second filter 40B is fixed to the circulatory airflow path 8, it is less like that position of the second filter 40B is changed. Accordingly, infiltration of the lint into the heat exchanger, which is caused by inappropriate installation of the second filter 40B, hardly occurs.

**[0083]** The filter 40 causes pressure loss of the dry air. As a result of the pressure loss, velocity distribution of the dry air is uniformed (that is, flow of the dry air is rectified). As shown in Figs. 4 and 5, the filter 40 is disposed immediately before the heat exchanger 80. Accordingly, the rectified dry air flows into the heat exchanger 80.

**[0084]** In general, if the circulatory airflow path is shortened in order to downsize the washing and drying machine, it may be difficult to install a rectification mechanism (for example, a straight pipe) in the circulatory airflow path. However, according to this embodiment, since the filter 40 rectifies the dry air, flow length required for



rectifying the dry air becomes shorter. Inflow of the rectified dry air to the heat exchanger 80 inhibits considerable local change in the heat exchange efficiency. The heat exchange efficiency of the heat exchanger 80 is thereby improved.

**[0085]** As described above, the filter 40 provided at the upstream position of the heat exchanger 80 rectifies the dry air without installation of any rectification mechanism (for example, a straight pipe) in the circulatory airflow path 8, which preferably results in the shorter circulatory airflow path 8.

**[0086]** As shown in Figs. 2 and 5, the dehumidifier 34 of the heat exchanger 80 includes an introductory surface 534 to which the dry air flows. The filter 40 is disposed near the introductory surface 534. Accordingly, the dry air rectified with the filter 40 is linearly sent to the dehumidifier 34 immediately after the filter 40.

**[0087]** As described above, the filter 40 rectifies the dry air. The rectification of the dry air with the filter 40 reduces the flow velocity of the dry air. Since the circulatory airflow path 8 hardly inflects a flow direction of the dry air between the filter 40 and the introductory surface 534, the dry air linearly flows into the dehumidifier 34 immediately after its flow velocity reduction. Consequently, it is less likely that the dry air passed through the dehumidified 34 becomes locally high flow velocity, so that the condensed water component at the dehumidified 34 hardly scatters.

**[0088]** As shown in Fig. 5, the washing and drying machine 500 further comprises a recovery structure 35 configured to recover the condensed water components at the dehumidifier 34. The recovery structure 35 is disposed below the dehumidifier 34. As described above, since the filter 40 inhibits the dispersion of the condensed water components at the dehumidifier 34, the water components may be sufficiently recovered by using the compact recovery structure 35. Accordingly, the compact washing and drying machine 500 is provided.

**[0089]** A concavity (not shown) is formed on the recovery structure 35. The condensed water components at the dehumidifier 34 run down on a surface of the dehumidifier and seep to the concavity. The concavity ranges to receive the water components which may be dispersed downstream by the dry air.

**[0090]** As described above, the filter 40 configured to rectify the dry air decreases the dispersion of the condensed water components at the dehumidifier 34. Accordingly, narrower area of the concavity is required to receive the water components seeping from the dehumidifier 34. Accordingly, the water components may be sufficiently collected with the compact recovery structure 35.

**[0091]** As described above, the water components are less scattered because of the filter 40 and appropriately recovered with the recovery structure 35. The recovered water components are preferably discharged from the concavity of the recovery structure 35 to the outside of the washing and drying machine 500. For example, the

water components may be drained together with the wash water from a drain outlet below the housing 1.

**[0092]** The recovery structure 35 is disposed in the upper space of the housing 1 together with the heat exchanger 80. Accordingly, the water components recovered with the recovery structure 35 is appropriately drained using potential energy. The discharge of the water components from the recovery structure 35 does not require any dedicated discharge system such as a pump, which results in the compact washing and drying machine 500.

**[0093]** As described above, the filter 40 immediately before the heat exchanger 80 effectively inhibits the inflow of the lint and other foreign objects into the heat exchanger 80. Nevertheless, as a result of longer usage of the washing and drying machine 500, the lint and other foreign objects in some cases become adhered to and/or accumulated in the heat exchanger 80.

**[0094]** As described above, the heat exchanger 80 is provided at the upper portion in the housing 1. The worker may remove the first filter 40A through the opening 40c formed on the upper wall 1c of the housing 1. Subsequently, the worker may remove the second filter 40B from the circulatory airflow path 8 with a dedicated tool. The worker may access the heat exchanger 80 to remove the lint and other foreign objects from the heat exchanger 80. The worker with standing near the front wall 1e of the housing 1 may perform the series of operations such as removing the first filter 40A, removing the second filter 40B and removing the lint and other foreign matter from the heat exchanger 80, which results in more efficient maintenance for the washing and drying machine 500.

(Configuration of Filter)

**[0095]** Configuration of the filter 40 is now described with reference to Fig. 5.

**[0096]** The substantially cylindrical first filter 40A of the filter 40 includes a coarser filter mesh than the filter mesh used as the second filter 40B. The first filter 40A includes a peripheral surface formed with an opening used as the inflow portion 41 into which the dry air flows. The dry air exhausted from the drum 3 flows into the first filter 40A via the inflow portion 41.

**[0097]** The second filter 40B fixed at the downstream portion of the first filter 40A includes a flat filter mesh.

**[0098]** The filter 40 comprises a cover part 42 disposed above the first filter 40A. When the first filter 40A is mounted on the washing and drying machine 500, the cover part 42 is fitted into the opening 40c formed on the upper wall 1c of the housing 1. The cover part 42 is preferably configured to be gripped by the user. When the user mounts the first filter 40A, the user may use the cover part 42 as a knob.

**[0099]** The substantially cylindrical first filter 40A includes an area  $L_L$  which causes considerable pressure loss, and an area  $L_S$  which causes less pressure loss. The area  $L_S$  at a substantially center portion of the first

filter 40A confronts the inflow portion 41 to directly collide with the dry air flowing from the inflow portion 41. The area  $L_L$  exists above and below the area  $L_S$ .

**[0100]** The dry air passed through the cylindrical first filter 40A configured to generate the aforementioned pressure loss distribution flows into the heat exchanger 80. As a result of the aforementioned pressure loss, the velocity distribution of the dry air which becomes higher speed in an upper portion of the dehumidifier 34 and lower speed in a lower portion of the dehumidifier 34 is obtained. The cylindrical first filter 40A is preferably disposed near the introductory surface 534 of the dehumidifier 34, which results in less dispersion of the condensed water components at the dehumidifier 34.

**[0101]** Droplets of the condensed water components at the dehumidifier 34 are smaller at the upper portion of the dehumidifier 34. The droplets combine with droplets of other water components during running down. Consequently, the droplets of the water components gradually become larger as running down. Accordingly, larger droplets of the water components become adhered to the lower portion of the dehumidifier 34 whereas smaller droplets of the water components become adhered to the upper portion of the dehumidifier 34.

**[0102]** As described above, the velocity of the dry air around the lower portion of the dehumidifier 34 is lower than the velocity of the dry air at the upper portion of the dehumidifier 34. Accordingly, it is less likely that the larger droplets of the water components scatter, which results in narrower dispersion range of the water component condensed at the dehumidifier 34. Accordingly, the condensed water component at the dehumidifier 34 may be appropriately recovered using the smaller recovery structure 35.

**[0103]** In this embodiment, the filter 40 including the first filter 40A and the second filter 40B performs two-step filtering process. Alternatively, the washing and drying machine may comprise a filter device configured to perform one-step filtering process by using a single filter element. Furthermore, the washing and drying machine may also comprise a filter device configured to perform multi-step (more than two steps) filtering process by using more than two filter elements.

**[0104]** In this embodiment, the filter 40 comprises the substantially cylindrical first filter 40A. Alternatively, the washing and drying machine may also comprise a flat or any other shape of a filter element.

(Comparison with Conventional Washing and Drying Machine)

**[0105]** The washing and drying machine 500 according to this embodiment comprises, as described above, the heat pump device 30 and the filter 40 fastened to the heat pump device 30. The filter 40 and the heat exchanger 80 of the heat pump device 30 are both disposed in the upper space of the housing 1 (space above the water vessel 2). Accordingly, the filter 40 is disposed near the

heat exchanger 80.

**[0106]** The filter 40, the heat exchanger 80 and the blower 9 are sequentially disposed in order along the flow direction of the dry air. The filter 40 rectifies the dry air. The rectified dry air flows into the heat exchanger 80. The heat exchanger 80 dehumidifies and heats the dry air. The blower 9 thereafter blows the dry air to the drum 3.

**[0107]** A conventional washing and drying machine comprises a heat pump device disposed in the lower space of the housing (space below the water vessel), and a filter disposed in the upper space of the housing (space above the water vessel). The filter, the blower and the heat exchanger are sequentially disposed in order along the flow direction of the dry air.

**[0108]** As described above, in this embodiment, since the filter 40 is disposed near the heat exchanger 80, the dry air is circulated using the shorter circulatory airflow path 8 than the circulatory airflow path adopted in the aforementioned conventional washing and drying machine. Accordingly, the pressure loss of the dry air flowing along the circulatory airflow path 8 is reduced. The reduction in the pressure loss of the dry air results in less power consumption of the blower 9 to blow the dry air. In addition, the reduction in the pressure loss of the dry air may increase flow rate of the dry air flowing along the circulatory airflow path 8.

**[0109]** The filter 40 disposed in the shorter circulatory airflow path 8 rectifies the dry air. The rectification of the dry air improves the heat exchange efficiency of the heat exchanger 80. Consequently, in comparison to the conventional washing and drying machine, an amount of the heat exchange considerably increases per unit time, which results in power saving and shorter drying time.

(Temperature Detection of Dry Air)

**[0110]** Temperature detection for the dry air is now described with reference to Fig. 5.

**[0111]** The washing and drying machine 500 further comprises a first temperature sensor 36 and a second temperature sensor 37. The first temperature sensor 36 and the second temperature sensor 37 are both used for detecting temperature of the dry air in the circulatory airflow path 8.

**[0112]** The first temperature sensor 36 detects the temperature of the dry air flowing between the drum 3 and the heat exchanger 80. The first temperature sensor 36 is disposed between the filter 40 and the dehumidifier 34.

**[0113]** The second temperature sensor 37 detects the temperature of the dry air between the heat exchanger 80 and the drum 3. The second temperature sensor 37 is disposed immediately after the blower 9.

**[0114]** The first temperature sensor 36 detects the temperature of the dry air before the dry air is dehumidified and heated by the heat exchanger 80. The second temperature sensor 37 detects the temperature of the dry air after the dry air is dehumidified and heated by the

heat exchanger 80. Output signals of the first temperature sensor 36 and the second temperature sensor 37 are used for controlling the heat pump device 30.

**[0115]** The first temperature sensor 36 between the filter 40 and the heat exchanger 80 is provided near the area  $L_L$  where the pressure loss of the substantially cylindrical first filter 40A is larger (upper or lower portion of the first filter 40A). In the first filter 40A, the lint and other foreign objects less often clog the area  $L_L$  with larger pressure loss in comparison to the area  $L_S$  with smaller pressure loss. Accordingly, the first temperature sensor 36 near the area  $L_L$  may more accurately detect the temperature of the dry air for a long time. Since the temperature detected with the first temperature sensor 36 may change if the lint and other foreign objects clog the filter 40, the output signals of the first temperature sensor 36 may be used for detecting the clogging of the filter 40. Accordingly, the first temperature sensor 36 near the area  $L_L$  may also accurately detect the clogging of the filter 40 for a long time.

**[0116]** The first temperature sensor 36 between the filter 40 and the heat exchanger 80 and the second temperature sensor 37 disposed at a downstream position of the blower 9 are located in the shorter circulatory air-flow path 8. An interval between the first temperature sensor 36 and the second temperature sensor 37 becomes shorter. The first temperature sensor 36 and the second temperature sensor 37 in the shorter interval are less sensitive to error factors (for example, leakage of the dry air) which may cause errors in the temperature detection. Accordingly, the first temperature sensor 36 and the second temperature sensor 37 may accurately detect the temperature of the dry air with less sensitivity to the error factors such as the leakage of the dry air.

(Support mechanism)

**[0117]** Fig. 8 is a perspective view of the heat pump device 30 supported by the support mechanism. Fig. 9 shows the support mechanism mounted on the housing 1.

**[0118]** The washing and drying machine 500 further comprises a support mechanism 560 configured to support the heat pump device 30 in the housing 1. The support mechanism 560 includes a supporting member 61 configured to support the heat pump device 30, and a confining member 62 configured to confine upward displacement of the heat pump device 30.

**[0119]** As shown in Fig. 7, both ends of the supporting member 61 supporting the heat pump device 30 between the compressor 31 and the confining member 62 are coupled to the upper edges of the right wall 1a and the left wall 1b, respectively. Similarly, both ends of the confining member 62 are coupled to the upper edges of the right wall 1a and the left wall 1b, respectively.

**[0120]** As shown in Figs. 8 and 9, the supporting member 61 extending between the right wall 1a and the left wall 1b below the heating portion 32 and/or the dehumid-

ifier 34, which are disposed at an upstream position of the compressor 31, supports the heat pump device 30. The confining member 62 extends between the right wall 1a and the left wall 1b at a farther position from the compressor 31 than the supporting member 61 and confines the upward displacement of the heat pump device 30. In this embodiment, the supporting member 61 is adjacent to the compressor 31. The confining member 62 extends above the filter 40 disposed at an upstream position of the heat pump device 30.

**[0121]** As shown in Fig. 7A, the washing and drying machine 500 further comprises a screw 70 configured to fix the heat pump device 30 to the supporting member 61, and a helical coil wire screw thread insert (not shown) configured to engage with the screw 70. As shown in Fig. 7B, the washing and drying machine 500 further comprises a screw 71 (refer to Fig. 6) configured to fix the filter 40 to the confining member 62 and a helical coil wire screw thread insert 72 configured to engage with the screw 71. As a result of connection between the filter 40 and the confining member 62, the heat pump device 30 is fixed to the confining member 62.

**[0122]** In the heat pump device 30, the compressor 31 is heavier. The weight of the compressor 31 is applied to the right wall 1a and the left wall 1b via the supporting member 61 supporting the heat pump device 30 near the compressor 31. Consequently, the weight of the compressor 31 reduces vibration of the upper edges of the right wall 1a and the left wall 1b caused by a vibration factor such as the rotation of the drum 3. The load of the weight of the heat pump device 30 against the right wall 1a and the left wall 1b increases weight of a vibratory element group including the right wall 1a and the left wall 1b. The increase in the weight of the vibratory element group including the right wall 1a and the left wall 1b results in less vibratory amplitude under the same excitation force. Consequently, since the right wall 1a and the left wall 1b of the housing 1 are subject to considerably downward force, even if the right wall 1a and the left wall 1b are affected by the rotation of the drum 3 or other vibration factors, the vibration of the right wall 1a and the left wall 1b is suitably reduced. Overall vibration of the housing 1 thereby decreases.

**[0123]** The support mechanism 560 comprising the supporting member 61 uses the gravity working on the heat pump device 30 including the compressor 31 to press the upper edges of the right wall 1a and the left wall 1b to effectively decrease the vibration of the right wall 1a and the left wall 1b of the housing 1 caused by the rotation of the drum 3 and other vibration factors.

**[0124]** Fig. 11 is a perspective view showing another arrangement of the supporting member in the washing and drying machine 500. Fig. 12 is a schematic perspective view of the washing and drying machine 500. Another arrangement of the supporting member is now described with reference to Figs. 11 and 12.

**[0125]** The weight of the compressor 31 may be loaded to one of the right wall 1a and the left wall 1b. For example,

as shown in Fig. 11, the support mechanism 560 may comprise, instead of the aforementioned supporting member 61, a supporting member 63 extending between the right wall 1a and the rear wall 1d. As shown in Fig. 11, the compressor 31 is disposed at a corner between the right wall 1a and the rear wall 1d. Since the compressor 31 is surrounded by the right wall 1a, the rear wall 1d and the supporting member 63, even if the washing and drying machine 500 is dropped or toppled, the heavier compressor 31 is appropriately supported by the right wall 1a, the rear wall 1d and the supporting member 63.

**[0126]** The support mechanism 560 is now described in further detail with reference to Figs. 6 to 10.

**[0127]** As shown in Figs. 4 and 6, the blower 9 near the compressor 31 is fastened to the heat pump device 30 with the fastening member 38. Accordingly, the weight load of the blower 9 is applied to the right wall 1a and/or the left wall 1b in addition to the weight of the heat pump device 30, which results in less vibration of the right wall 1a and/or the left wall 1b of the housing 1 caused by the rotation of the drum 3 or other vibratory elements.

**[0128]** The blower 9 includes a fan 9b configured to cause the dry air flow in the circulatory airflow path 8, and a blast motor 9a configured to rotate the fan 9b. When the blast motor 9a rotates the fan 9b, the dry air passed through the heat pump device 30 is sent into the drum 3. The blast motor 9a has relatively great weight as with the compressor 31. As described above, the blower 9 is disposed near the compressor 31. The supporting member 61, 63 disposed below the blower 9 extends along the compressor 31 and the blower 9 to support the blower 9 in addition to supporting the compressor 31, which results in a simpler structure for supporting heavier elements (compressor 31 and blower 9). The simpler support mechanism 560 significantly contributes to reduction in a number of components, weight and cost of the washing and drying machine 500.

**[0129]** As described above, the confining member 62 extends between the right wall 1a and the left wall 1b above the heat pump device 30. The confining member 62 is farther from the compressor 31 than the supporting member 61.

**[0130]** The confining member 62 is now described with reference to Figs. 2, 3 and 6.

**[0131]** As shown in Figs. 2 and 3, the heavier compressor 31 and the heavier blower 9 are disposed near the rear wall 1d whereas lighter elements (for example, the heat exchanger 80) are closer to the front wall 1e than the compressor 31 and the blower 9. Accordingly, moment for uplifting the lighter elements near the front wall 1e works on the circulation mechanism of the dry air including the heat pump device 30.

**[0132]** The confining member 62 closer to the front wall 1e than the supporting member 61 inhibits the upward displacement of the lighter elements such as the heat exchanger 80. In this embodiment, the filter 40 away from the compressor 31 is connected to the heat pump device 30. The confining member 62 is provided across and

above the filter 40 between the heat pump device 30 and the front wall 1e. The confining member 62 appropriately confines the upward displacement of the filter 40 and the heat pump device 30 of the heat exchanger 80. Since the upward displacement of the lighter members between the compressor 31 and the front wall 1e is integrally confined with the confining member 62, the support mechanism 560 is simplified. Accordingly, a part number, weight and cost of the washing and drying machine 500 decrease.

**[0133]** As described above, the confining member 62 comes in contact with the filter 40 apart from the compressor 31 to confine the upward displacement of the heat pump device 30. The heavier compressor 31 causes the moment around the supporting member 61. The moment results in an upward force acting on the heat pump device 30 and the filter 40. The upward force applied to the heat pump device 30 and the filter 40 becomes greater as its working point becomes apart from the supporting member 61. Since the confining member 62 confines the upward displacement of the filter 40 to which the considerable force is applied, the heat pump device 30 and the filter 40 are stabilized in the upper space.

**[0134]** Alternatively, the confining member 62 may be provided across and above the heat exchange 80 of the heat pump device 30. The confining member 62 directly confines the upward displacement of the heat exchanger 80.

**[0135]** As described above, the heat pump device 30 and the elements (filter 40 and blower 9) around the heat pump device 30 are appropriately supported by the supporting member 61, 63 mounted across and below the heat pump device 30. Moreover, the confining member 62 is mounted across and above the heat pump device 30 and/or the filter 40. The confining member 62 and the supporting member 61, 63 disposed above and below the heat pump device 30, respectively, suitably reduce vertical vibration amplitude, which results in decrease in the overall vibration of the housing 1 caused by the rotation of the drum 3.

**[0136]** The aforementioned support mechanism 560 inhibits, in addition to the vibration of the housing 1, drawbacks such as breakage or damage of securing members such as screws 70, 71 configured to fasten various elements disposed in the upper space in the housing 1. The support mechanism 560 may appropriately retain the heat pump device 30 and the elements (filter 40 and blower 9) around the heat pump device 30 even when, for example, the washing and drying machine 500 is accidentally dropped or toppled during the transport and/or installation thereof. The advantageous effect of the support mechanism 560 on the securing members used for fastening the elements is now described.

**[0137]** Several components are also disposed in the upper space of the housing of a general washing and drying machine. The components disposed in the upper space are typically connected to a supporting element such as the upper wall of the housing. If the washing and

drying machine is dropped or toppled, the securing members (for example, helical coil wire screw thread insert used as a screw and/or a nut) for fastening the components in the upper space to the supporting element are subject to greater tensile stress from the gravity working on the components in the upper space as well as the impact force caused by the toppling and drop. The securing members used for fixation of heavy components are subject to great tensile stress. Accordingly, the securing members used for the fixation of the components in the upper space of the general washing and drying machine more easily break when the washing and drying machine is toppled or dropped.

**[0138]** In this embodiment, the compressor 31 and the blower 9 of the heat pump device 30 are heavier. The supporting member 61, 63 appropriately support the compressor 31 and/or the blower 9. Moreover, the confining member 62 farther from the compressor 31 than the supporting member 61, 63 is mounted across and above the heat pump device 30 and/or the filter 40.

**[0139]** When the washing and drying machine 500 is dropped or toppled, the supporting member 61, 63 is subject to the weight of the heat pump device 30 and/or the blower 9 and the impact force resulting from the drop or toppling of the washing and drying machine 500. The weight of the heat pump device 30 and/or the blower 9 and the impact force resulting from the drop or toppling of the washing and drying machine 500 work as compression force against the supporting member 61, 63.

**[0140]** The compression force working on the supporting member 61, 63 also affects the securing members such as the screw 70 or helical coil wire screw thread insert configured to fasten the supporting member 61, 63 to the heat pump device 30/ blower 9. Nevertheless, unlike the tensile stress, it is less likely that the securing member is broken by the compression force.

**[0141]** In this embodiment, the supporting member 61, 63 is disposed near the heavier compressor 31. Consequently, the moment is generated around the supporting member 61, 63. The moment around the supporting member 61, 63 attempts to uplift the lighter elements (filter 40 and heat exchanger 80) between the supporting member 61, 63 and the front wall 1e. The moment around the supporting member 61, 63 results in the compression force on the confining member 62 mounted across and above the heat pump device 30 and/or the filter 40. The compression force working on the confining member 62 also affects the securing members such as the screw 71 or the helical coil wire screw thread insert 72 configured to fasten the confining member 62 to the heat pump device 30 and/or the filter 40. Nevertheless, unlike the tensile stress, it is less likely that the securing members are broken by the compression force.

**[0142]** As described above, the supporting member 61 near the compressor 31 appropriately supports the heat pump device 30. Moreover, the confining member 62 apart from the compressor 31 appropriately confines the upward displacement of the heat pump device 30 or the

filter 40 connected to the heat pump device 30. Accordingly, the support mechanism 560 may appropriately support the heat pump device 30 in the upper space of the housing 1.

5 **[0143]** The housing of the general washing and drying machine becomes taller according to height of the supporting member supporting the components in the upper space.

10 **[0144]** In this embodiment, the drum 3 and the water vessel 2 are tilted in the housing 1. Consequently, the upper space becomes wider near the rear wall 1d than near the front wall 1e. Larger elements (compressor 31 and/or blower 9) are disposed in the upper space near the rear wall 1d. Accordingly, sufficiently wide space is exploited to place the supporting member 61, 63 without increase in height of the housing 1.

15 **[0145]** The generatrix G defining the outer surface of the peripheral wall 521 of the water vessel 2 is tilted downward from the front wall 1e toward the rear wall 1d. Accordingly, the distance between the inner surface of the upper wall 1c defining an upper boundary of the upper space and the peripheral wall 521 of the water vessel 2 becomes longer upon approaching the rear wall 1d. Since the heat pump device 30 is closer to the rear wall 20 1d than to the front wall 1e, in addition to the heat pump device 30, the supporting members 61, 63 configured to support the heat pump device 30 are also appropriately disposed in the compact housing 1.

30 (Arrangement of Heat Pump Device)

**[0146]** The dehumidifier 34 and the heating portion 32 of the heat pump device 30 are preferably formed using highly conductive metal such as copper or aluminum. Since the heat pump device 30 is disposed above the water vessel 2 as described above, it is less likely that the heat pump device 30 is exposed to the wash water. Accordingly, metallic corrosion in the dehumidifier 34 and the heating portion 32, which may be caused by chemical components such as detergent, softener or bleach contained in the wash water, less likely occurs.

35 **[0147]** Since the dehumidifier 34 and the heating portion 32 of the heat exchanger 80 are linearly aligned with respect to the blower 9 along the circulatory airflow path 8 of the dry air, the dry air substantially linearly flows in the heat exchanger 80. In general, inflected flow of fluid induces drift and pressure loss of the fluid, but the linear arrangement of the dehumidifier 34 and the heating portion 32 according to this embodiment hardly causes such drift and pressure loss of the fluid, which results in efficient circulation of the dry air and less power consumption of the blower 9 to blow the dry air in the circulatory airflow path 8.

40 **[0148]** As a result of the less drift of the dry air, it is less likely that the dry air passing through the dehumidifier 34 locally becomes faster. As described above, the dehumidifier 34 condensates the water components in the dry air. If the faster flow of the dry air locally occurs

in the dehumidifier 34, the condensed water components is carried by the dry air once again to the drum 3 via the blower 9. Consequently, the clothing in the drum 3 may absorb the water components once again. In this embodiment, it is less likely that the linear arrangement of the dehumidifier 34 and the heating portion 32 causes the locally faster flow of the dry air as described above. Accordingly, it is less likely that the circulation of the condensed water component deteriorates the drying efficiency.

**[0149]** In general, under lower flow rate of fluid passing through a heat pump device, a heat absorption amount of an endothermic portion configured to absorb heat from the fluid goes down, which results in incomplete vaporization of refrigerant passing through the endothermic portion. Subsequently, the incompletely vaporized refrigerant may reach a compressor. The compressor may potentially malfunction as a result of compressing a devolatilized refrigerant.

**[0150]** In this embodiment, since the linear arrangement of the dehumidifier 34 and the heating portion 32 maintains appropriate flow rate of the dry air in the heat exchanger 80, complete vaporization of the refrigerant in the dehumidifier 34 may be easily achieved. Since it is less likely that devolatilized refrigerant flows into the compressor 31, the compressor 31 hardly malfunctions, which results in the more reliable washing and drying machine 500 comprising the heat pump device 30. As a result of the enhancement in reliability, it may be possible to continuously dehumidify the dry air without halting the compressor 31 to shorten drying operation period.

**[0151]** It should be noted that, as the refrigerant used in the heat pump device 30, any standard refrigerant such as HFC (hydrofluorocarbon)-based refrigerant, HFO (hydrofluoroolefin)-based refrigerant, and carbon dioxide refrigerant may be suitably used.

**[0152]** In this embodiment, the washing and drying machine 500 includes a washing function and a drying function. Alternatively, the principle of the aforementioned embodiment may be applied to a laundry machine without the drying function. A laundry machine without the drying function does not need the aforementioned heat pump device 30 or the various elements arranged along the circulatory airflow path 8.

**[0153]** In this embodiment, the washing and drying machine 500 is a drum-type washing and drying machine. Alternatively, the principle according to the aforementioned embodiment may be applied to a pulsator-type washing and drying machine.

**[0154]** In this embodiment, the washing and drying machine 500 heats and dehumidifies the dry air for drying the clothing with the heat pump device 30. Alternatively, the dry air may be heated with a heater. Moreover, the dry air may be dehumidified with an air-cooled dehumidifier.

**[0155]** The foregoing embodiment primarily includes the laundry machine configured as described below.

**[0156]** The laundry machine according to one aspect

of the present invention includes: a housing; a water vessel disposed in the housing; a detergent dispenser provided above the water vessel; a water supply channel in fluid communication with the detergent dispenser and the water vessel; a water supply valve configured to control water supply; and a formation member connected to the water supply valve to form a water filling pipe configured to supply water into the detergent dispenser, wherein the water filling pipe is disposed below the water supply valve.

**[0157]** According to the foregoing configuration, the water supplied under the water supply control by the water supply valve pass through the water filling pipe and reaches the detergent dispenser. The water thereafter passes through the water supply channel and is supplied into the water vessel. The water filling pipe is disposed below the water supply valve. When the water supply is complete, water around the water supply valve is appropriately drained. Since the water is less likely to remain around the water supply valve, it is less likely that mold grows around the water supply valve. Accordingly, since the water supplied to the water vessel is less likely to be contaminated by the mold, the laundry machine may maintain washing performance for a long time.

**[0158]** In the foregoing configuration, preferably, the laundry machine further includes a control substrate configured to control operation of the laundry machine, wherein the control substrate is disposed in a space above the detergent dispenser in the housing.

**[0159]** According to the foregoing configuration, since the water filling pipe is disposed below the water supply valve, the detergent dispenser is also placed at a lower position. A space is thereby formed above the detergent dispenser. The control substrate configured to control the operation of the laundry machine is disposed in the foregoing space. A more compact laundry machine may be provided since the control substrate exploits the space in the housing.

**[0160]** Since the control substrate is disposed over the detergent dispenser above the water vessel, electricians may access the control substrate with standing near the housing, which results in more efficient maintenance of the control substrate.

**[0161]** In the foregoing configuration, preferably, the control substrate includes a radiator, and the radiator is disposed near the formation member configured to form the water filling pipe.

**[0162]** According to the foregoing configuration, the formation member configured to form the water filling pipe is cooled with the water passing through the water filling pipe during the water supply. Accordingly, the heat generated in the control substrate efficiently radiates via the radiator of the control substrate near the formation member, so that it is less likely that heat accumulation makes the control substrate malfunction.

**[0163]** In the foregoing configuration, preferably, the radiator comes in contact with the formation member, the formation member is formed with a through-hole leading

to the radiator, and the water flowing into the water filling pipe through the through-hole comes in contact with the radiator.

**[0164]** According to the foregoing configuration, the water passing through the water filling pipe directly contacts the radiator of the control substrate. Therefore heat efficiently radiates from the control substrate. The water flowing into the water vessel is warmed with the heat radiation from the control substrate. Accordingly, the washing efficiency is improved.

**[0165]** In the foregoing configuration, preferably, the laundry machine further includes a check valve disposed at a connection between the water vessel and the water supply channel, wherein the check valve allows the water to flow from the detergent dispenser to the water vessel and prevents the water to flow from the water vessel to the detergent dispenser.

**[0166]** According to the foregoing configuration, the check valve is mounted at the connection between the water vessel and the water supply channel. Accordingly, the water flowing from the water supply valve may adequately pass through the check valve due to the hydraulic head pressure arising between the connection and the detergent dispenser. Since the water adequately passes through the check valve without increase in height of the detergent dispenser in order to obtain the hydraulic head pressure, a more compact laundry machine is provided.

**[0167]** The washing and drying machine according to another aspect of the present invention includes: the foregoing laundry machine; a rotatable drum internally mounted in the water vessel; and a drying mechanism configured to supply drying air into the drum for drying clothing in the drum.

**[0168]** According to the foregoing configuration, since the washing and drying machine including a washing function and a drying function is hardly affected by the contamination of water resulting from the mold around the water supply valve, the washing and drying machine may maintain a more effective washing function for a long time.

#### Industrial Applicability

**[0169]** The principle of the aforementioned embodiment may be suitably applied to various types of laundry machines and washing and drying machines such as drum-type and pulsator-type.

#### Claims

##### 1. A laundry machine comprising:

- a housing (1);
- a water vessel (2) disposed in the housing (1);
- a detergent dispenser (10) provided above the water vessel (2);
- a water supply channel (17) in fluid communica-

tion with the detergent dispenser (10) and the water vessel (2);

a water supply valve (14) configured to control water supply; and

a formation member (16) connected to the water supply valve (14) to form a water filling pipe (15) configured to supply water into the detergent dispenser (10),

wherein the water filling pipe (15) is disposed below the water supply valve (14).

##### 2. The laundry machine according to claim 1, further comprising:

a control substrate (50) configured to control operation of the laundry machine, wherein the control substrate (50) is disposed in a space above the detergent dispenser (10) in the housing (1).

##### 3. The laundry machine according to claim 2, wherein the control substrate (50) includes a radiator (50a), and the radiator (50a) is disposed near the formation member (16) configured to form the water filling pipe (15).

##### 4. The laundry machine according to claim 3, wherein the radiator (50a) comes in contact with the formation member (16), the formation member (16) is formed with a through-hole (16a) leading to the radiator (50a), and the water flowing into the water filling pipe (15) comes in contact with the radiator (50a) through the through-hole (16a).

##### 5. The laundry machine according to any one of claims 1 to 3, further comprising:

a check valve (18) disposed at a connection between the water vessel (2) and the water supply channel (17),

wherein the check valve (18) allows the water to flow from the detergent dispenser (10) to the water vessel (2) and prevents the water to flow from the water vessel (2) to the detergent dispenser (10).

##### 6. A washing and drying machine (500) comprising:

the laundry machine of one of preceding claims; a rotatable drum (3) internally mounted in the water; and

a drying mechanism configured to supply drying air into the drum (3) for drying clothing in the drum (3).

FIG.1

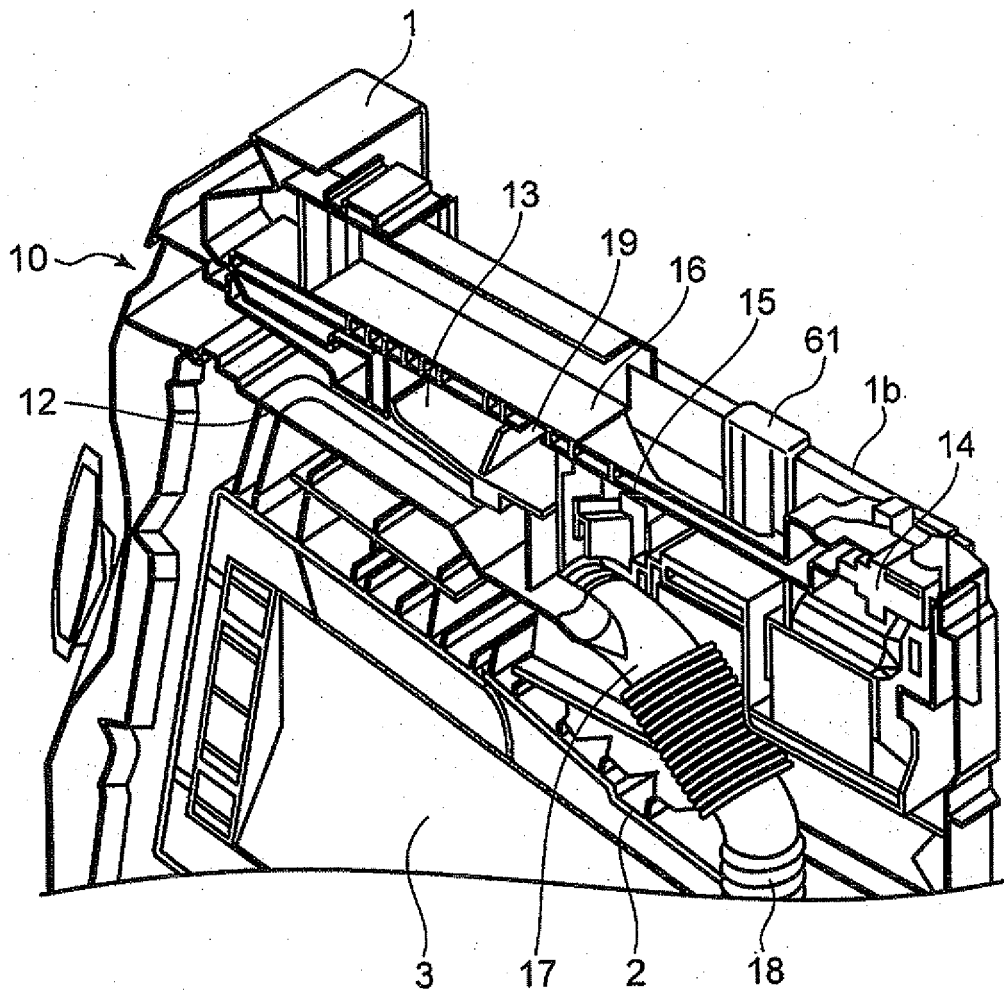



FIG.2

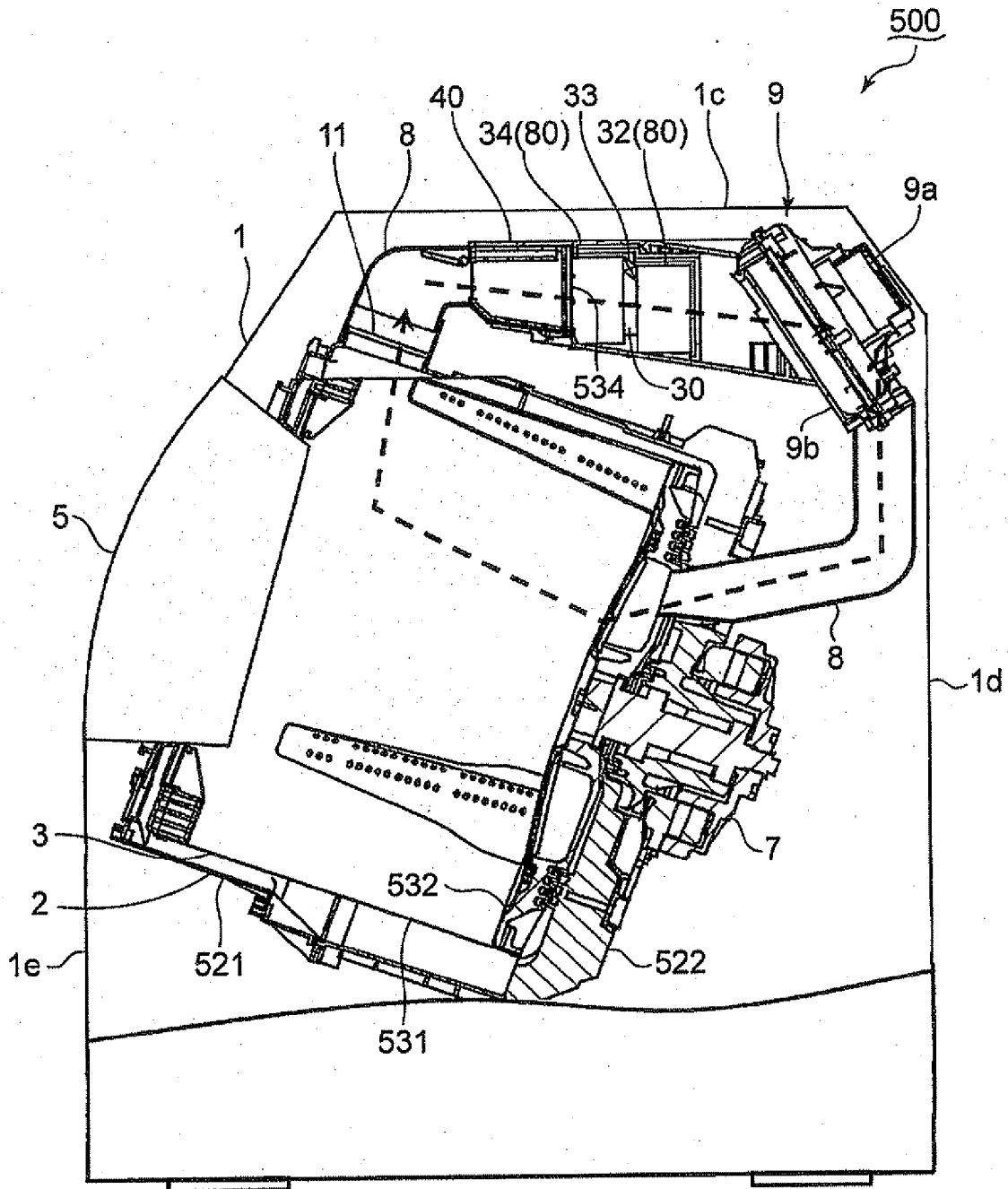

FIG.3

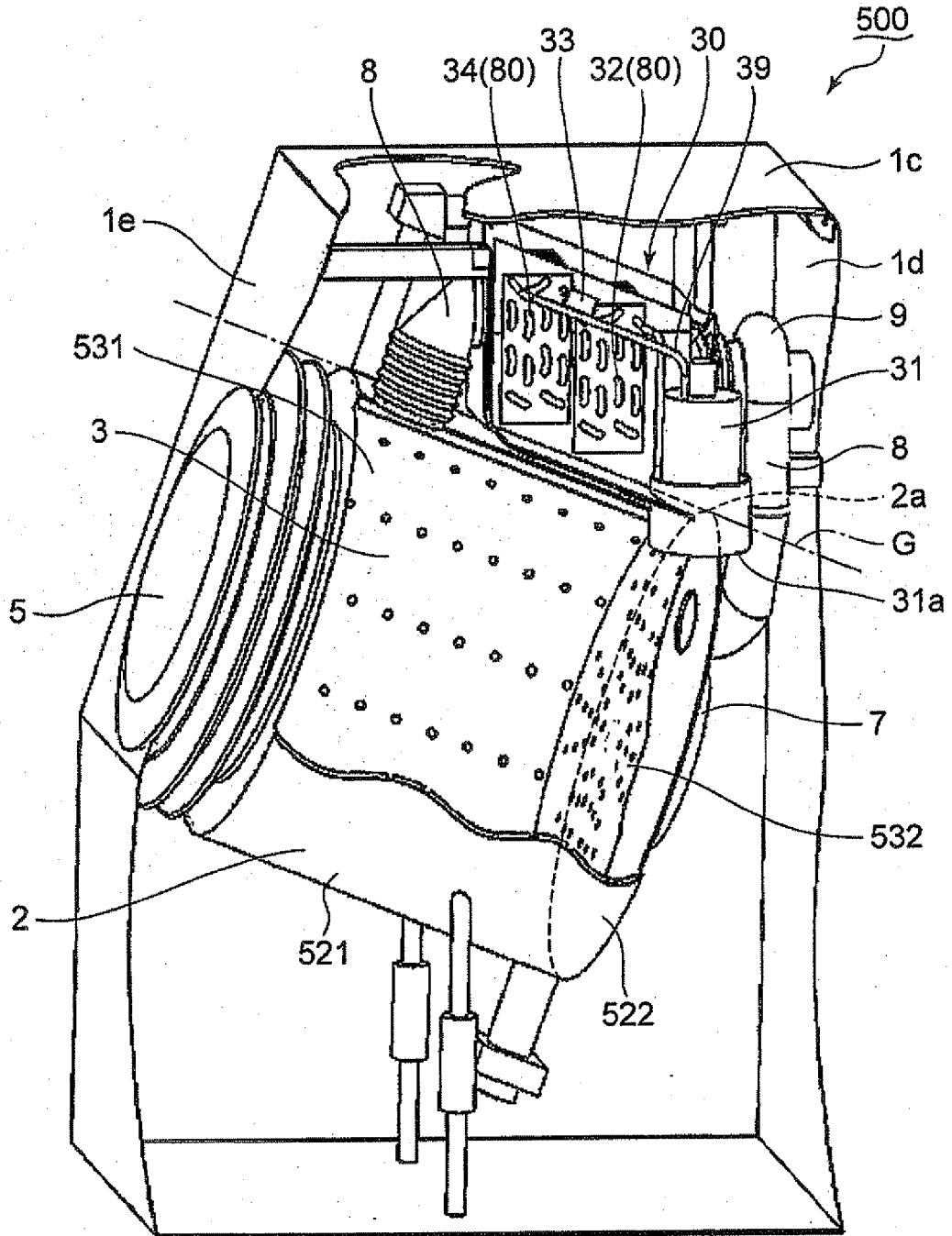

FIG.4

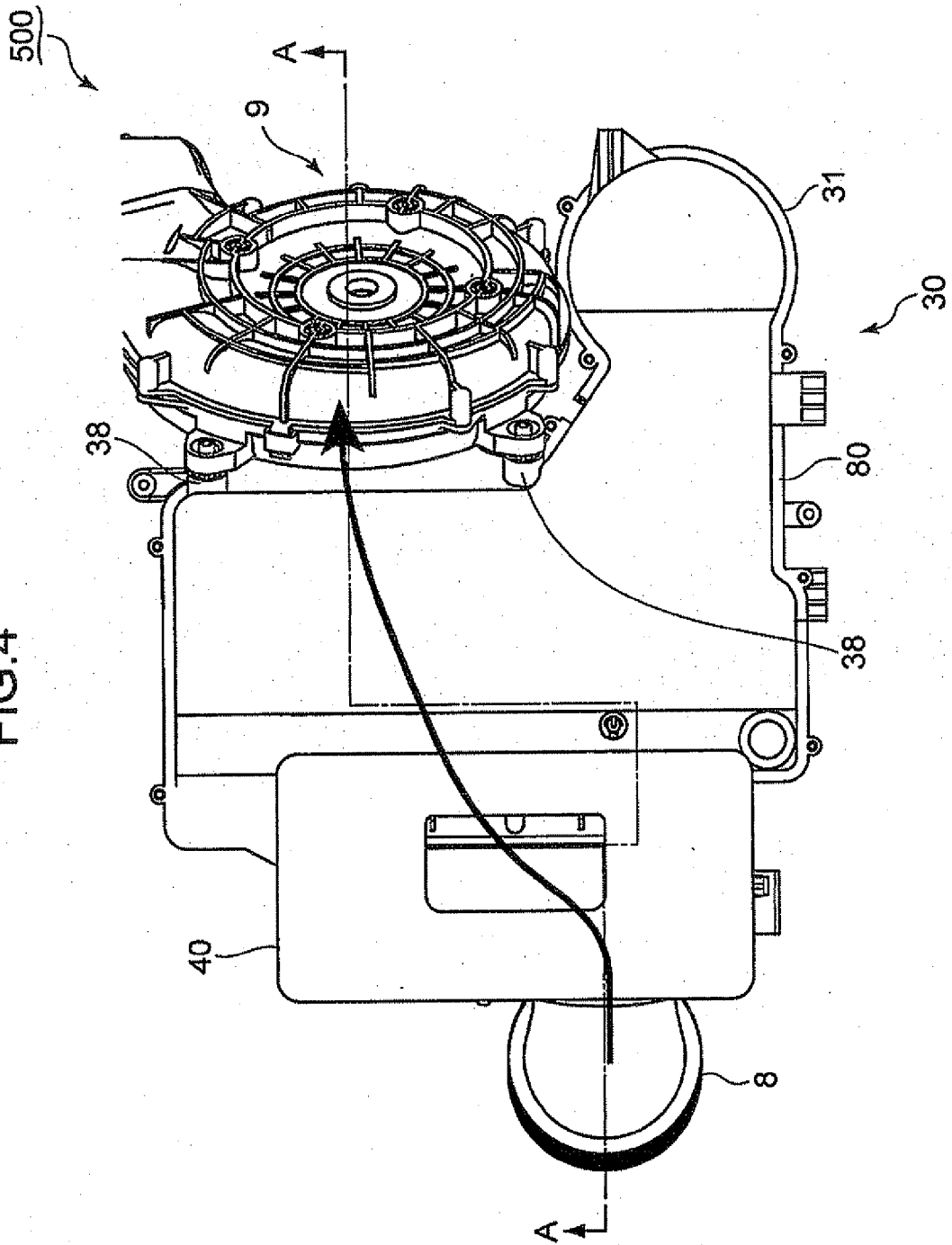

FIG.5

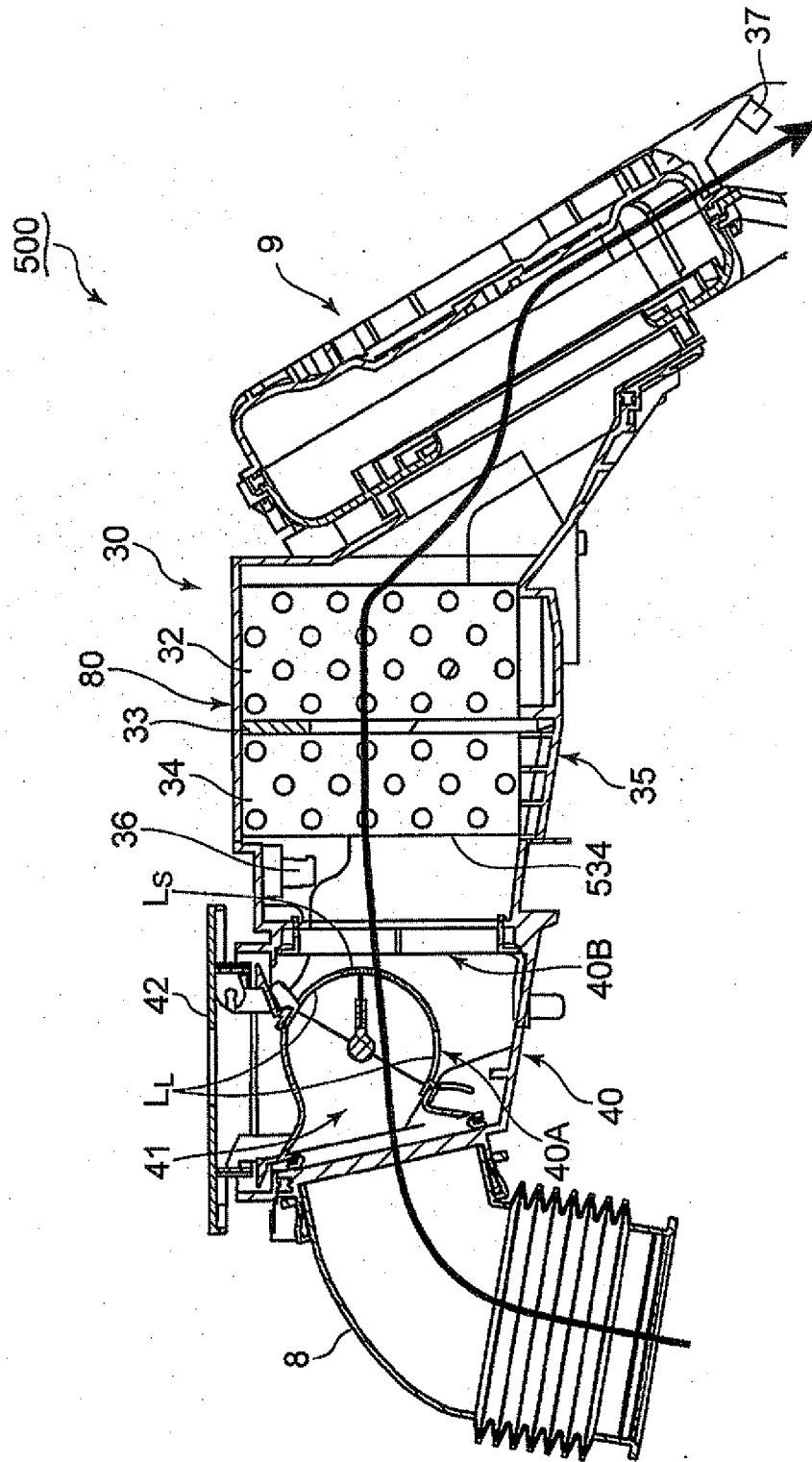

FIG.6

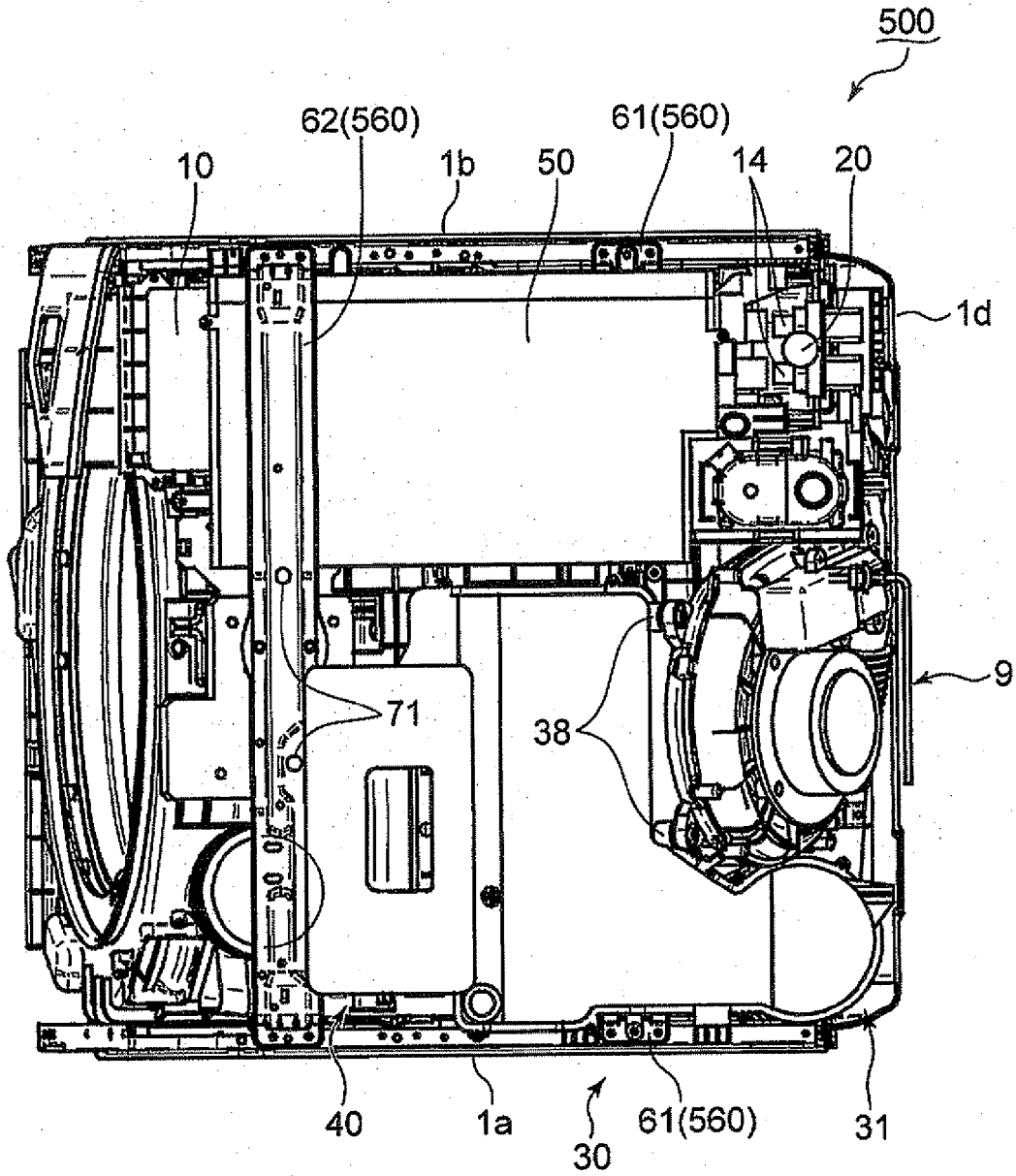

FIG.7A

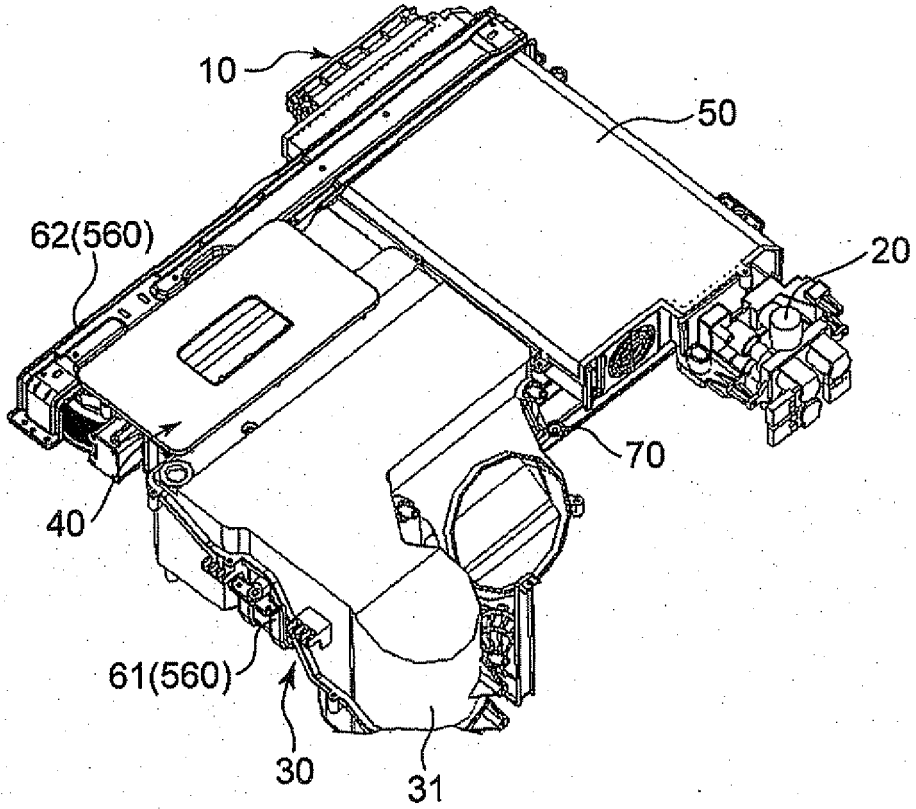

FIG.7B

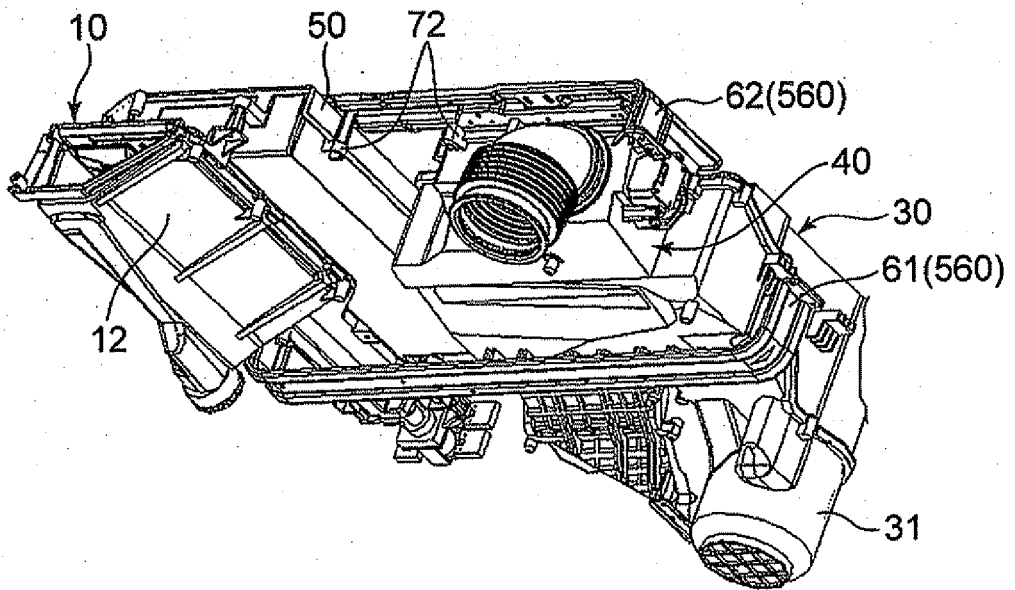

FIG.8

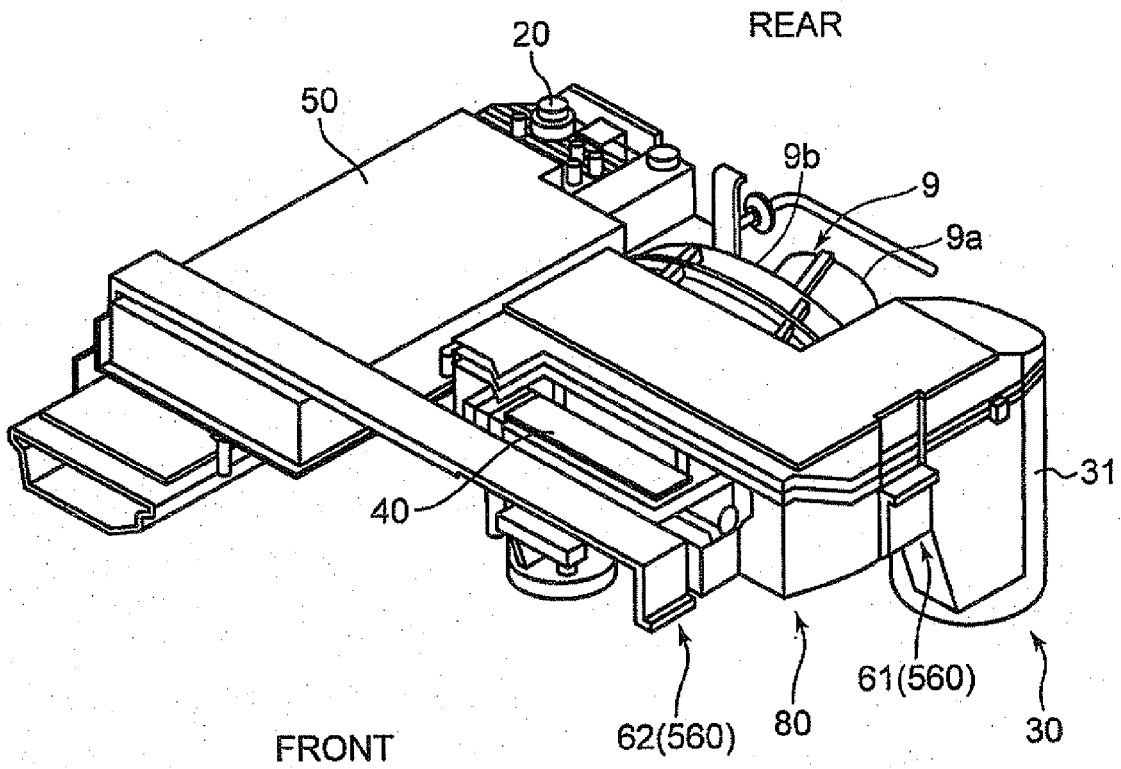

FIG.9

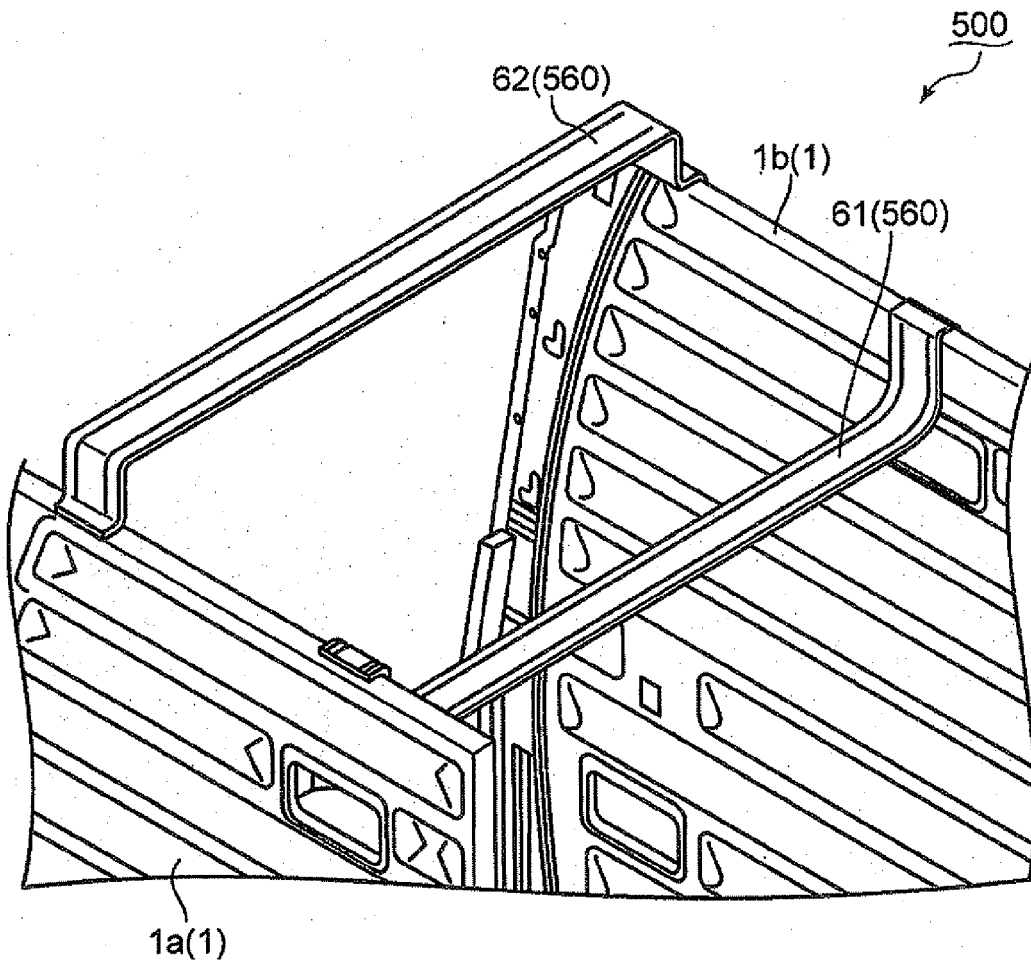



FIG.10

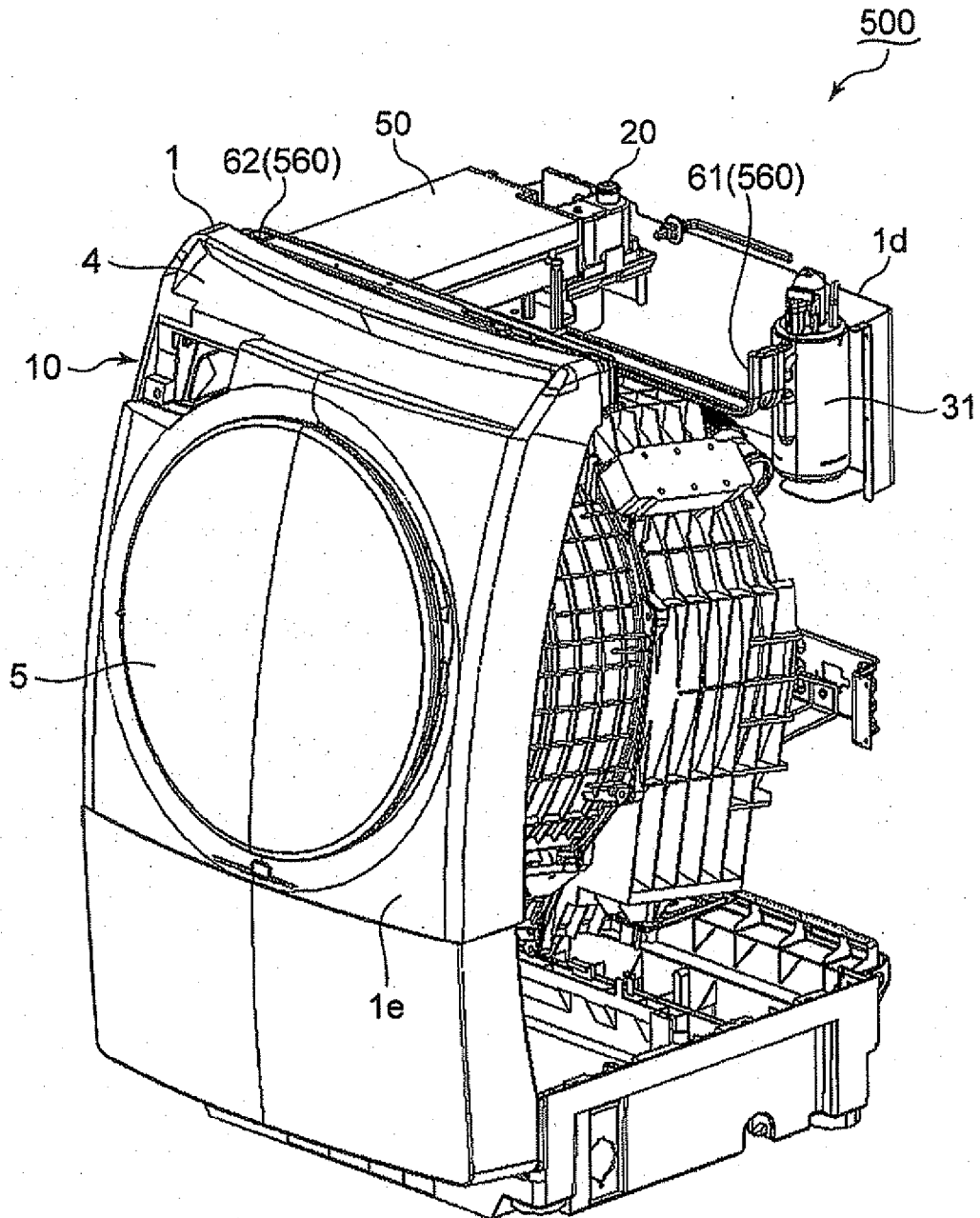

FIG.11

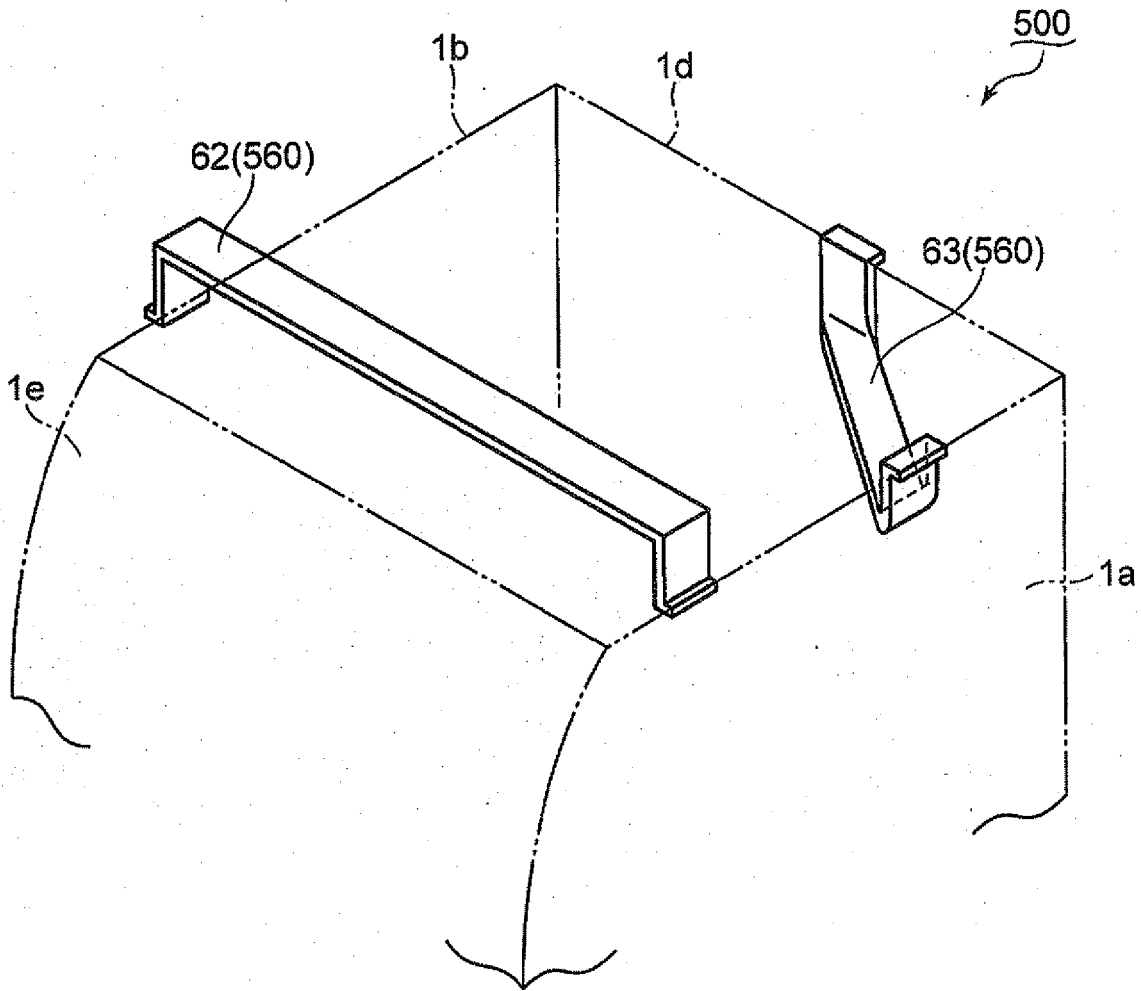

FIG.12

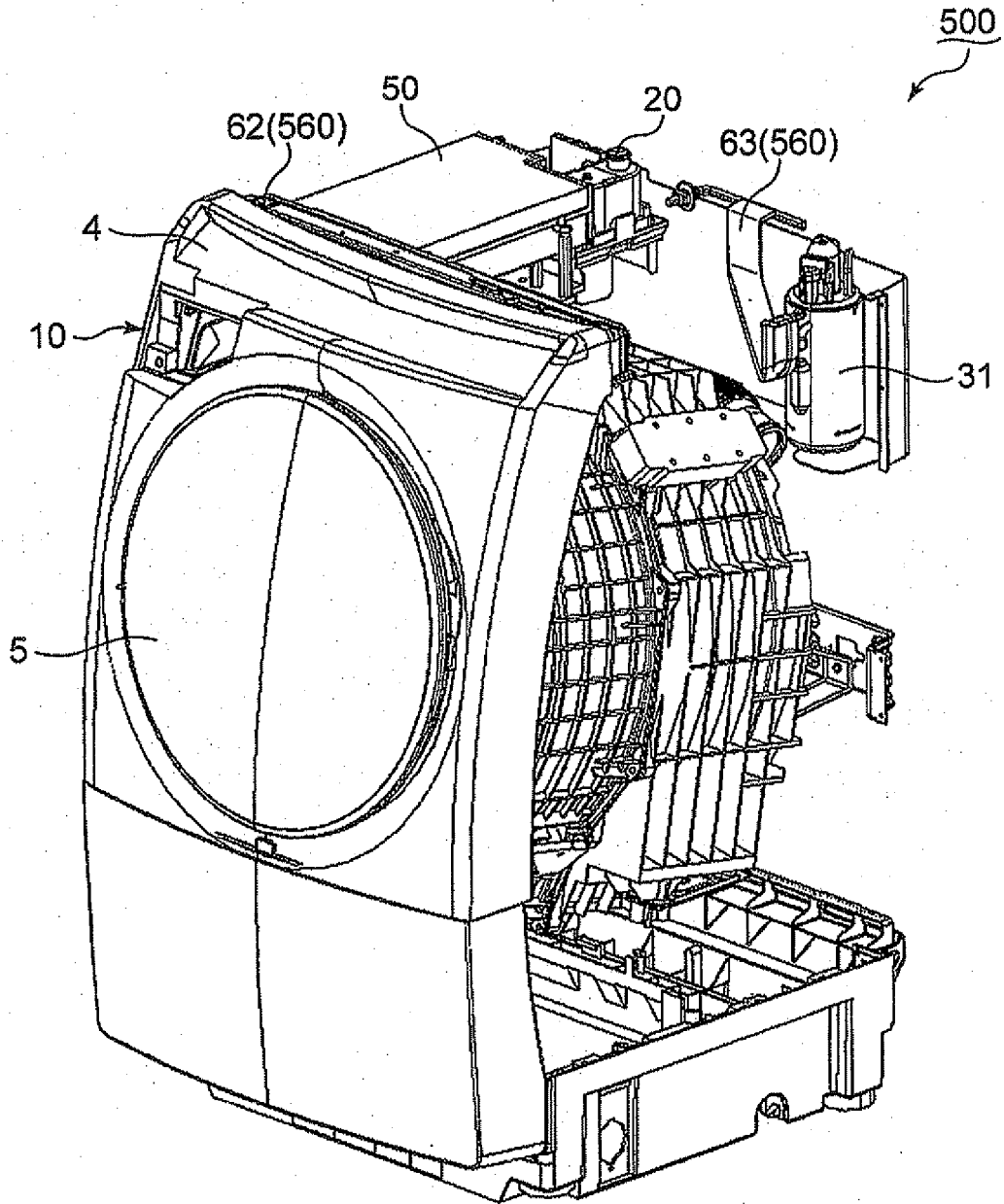

FIG.13

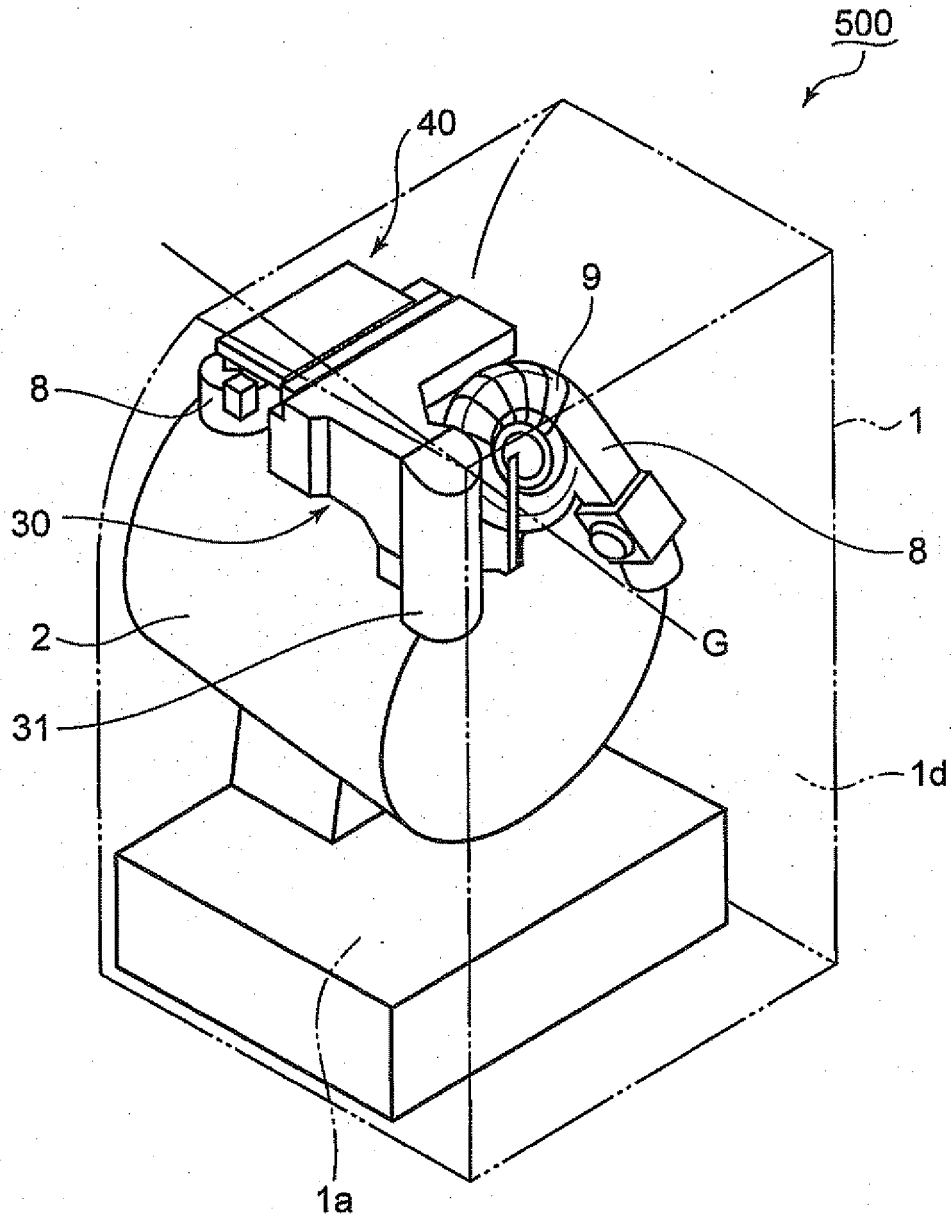

FIG.14

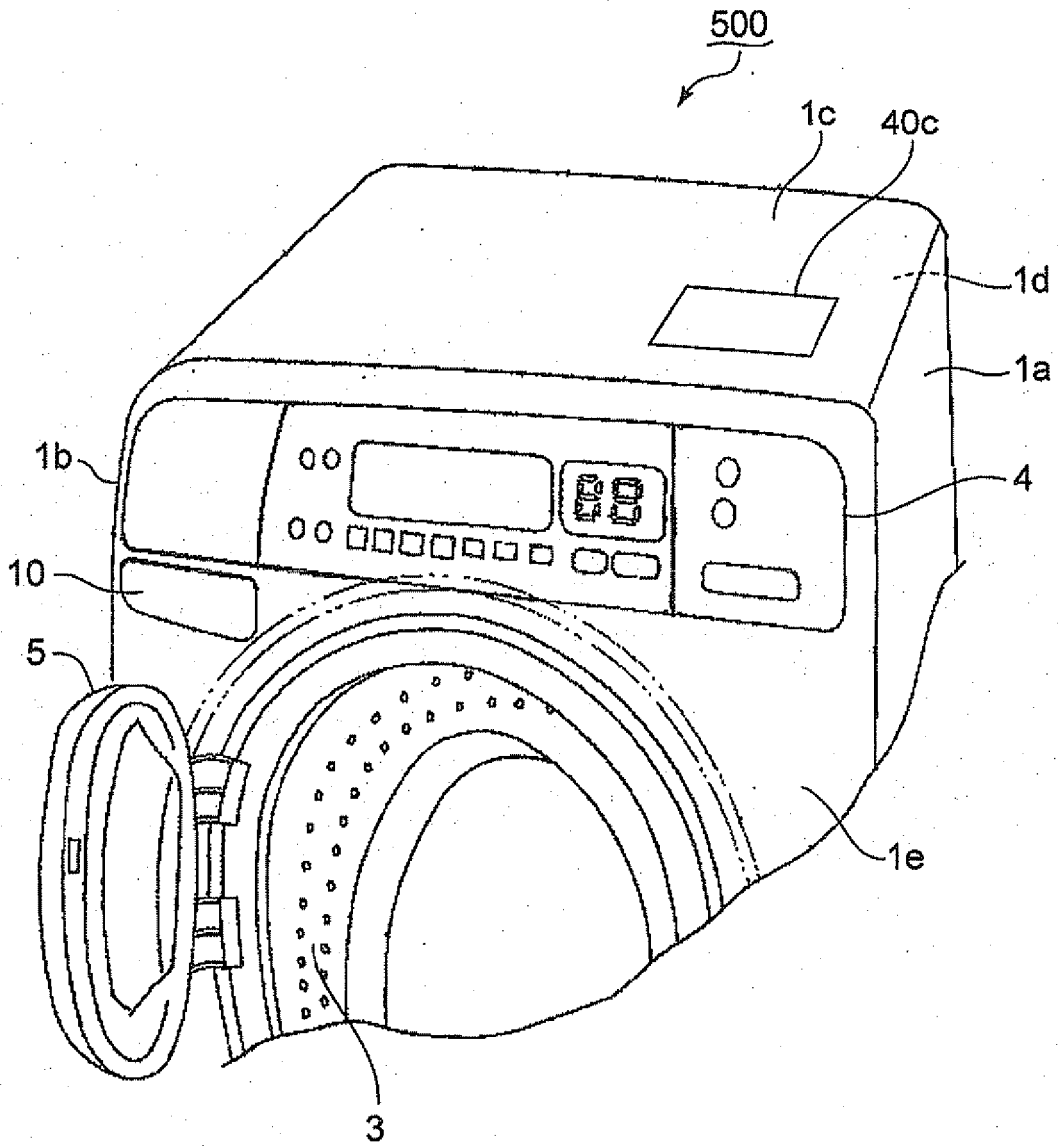

FIG.15

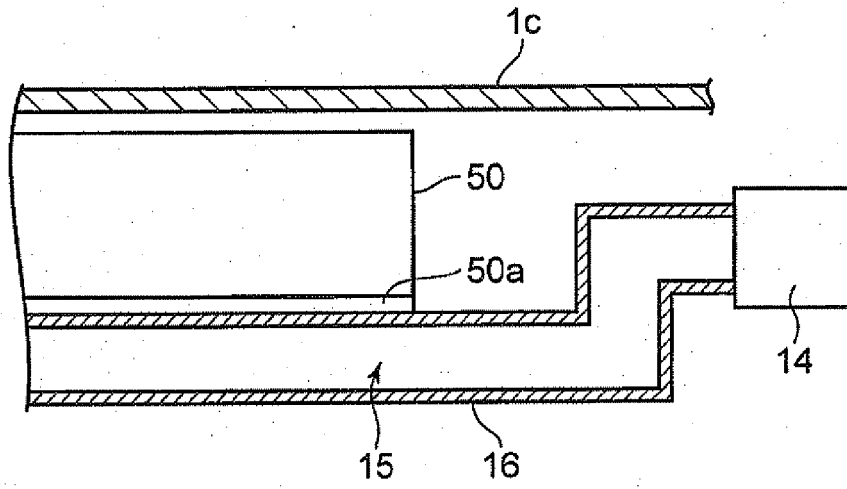

FIG.16

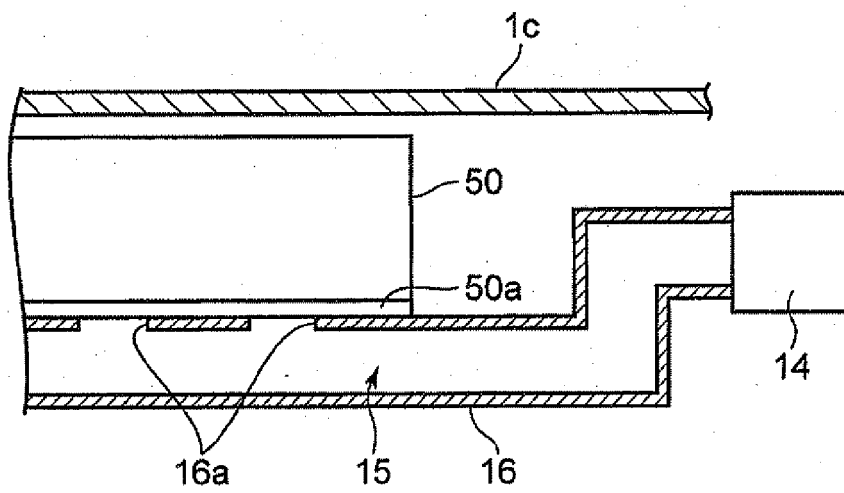

FIG.17

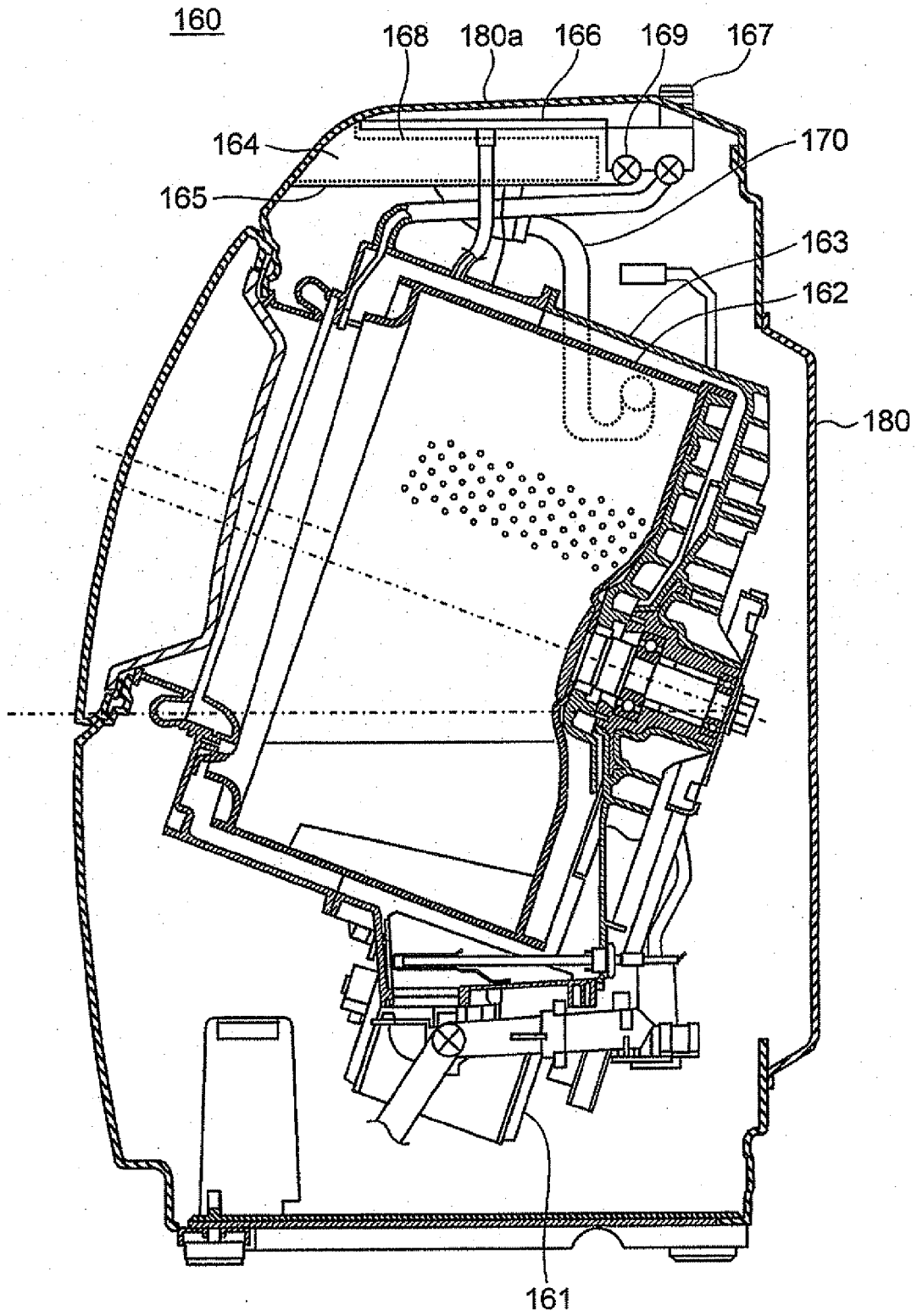

FIG.18

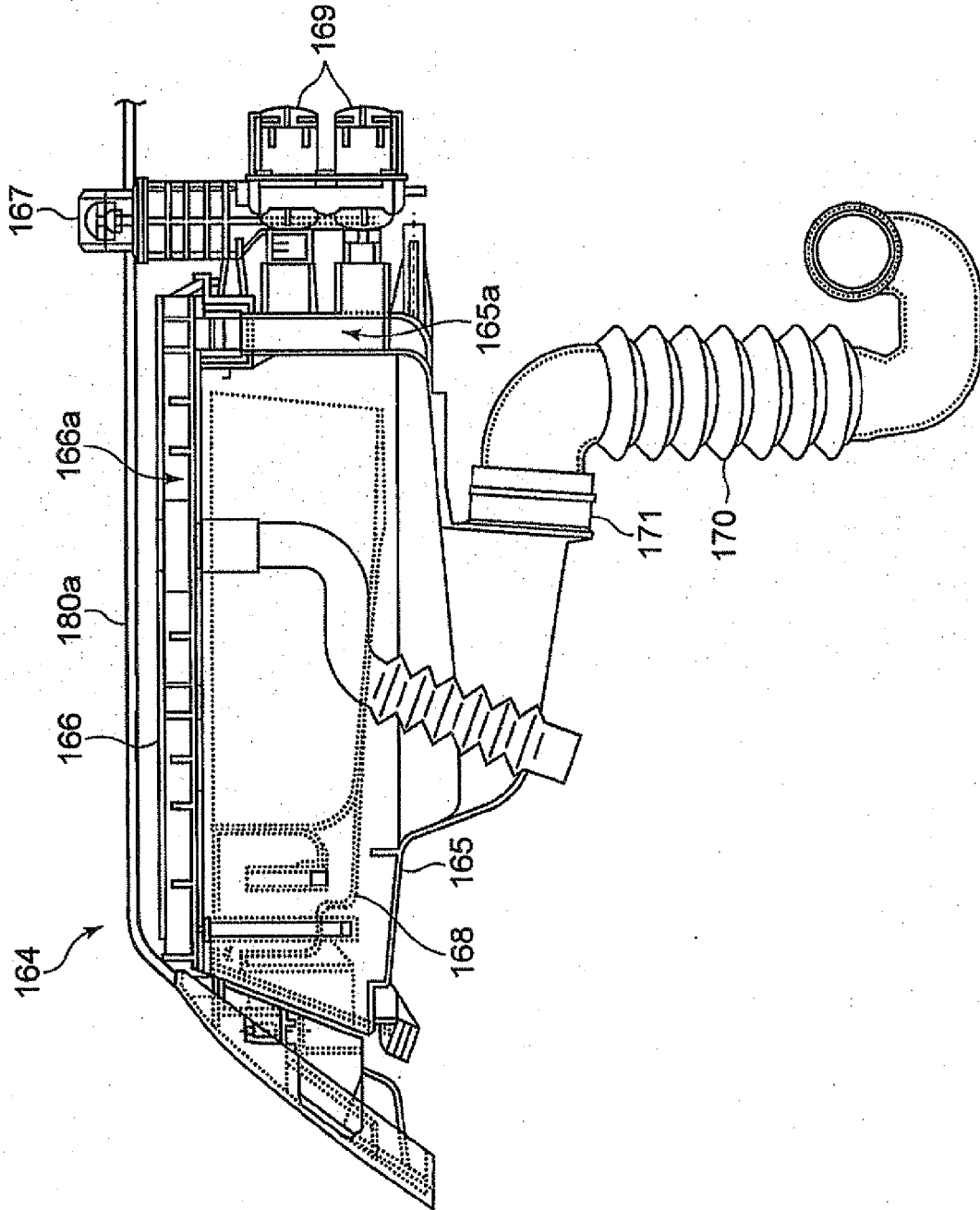
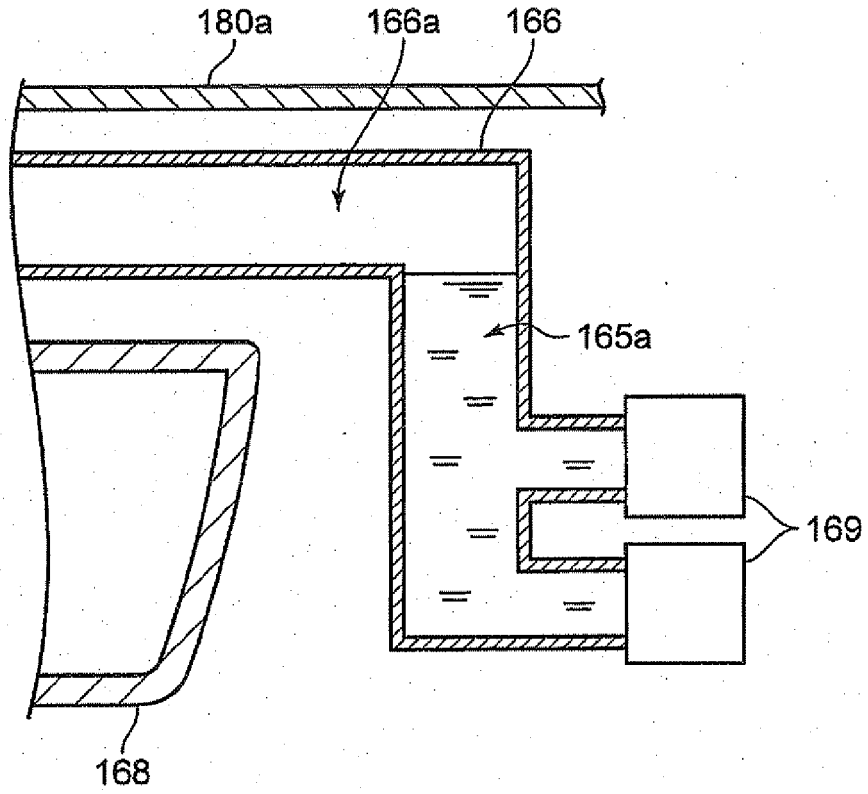



FIG.19





Europäisches  
Patentamt  
European  
Patent Office  
Office européen  
des brevets

## EUROPEAN SEARCH REPORT

Application Number  
EP 11 15 3957

DOCUMENTS CONSIDERED TO BE RELEVANT			
Category	Citation of document with indication, where appropriate, of relevant passages	Relevant to claim	CLASSIFICATION OF THE APPLICATION (IPC)
X	US 2004/148975 A1 (NO YANG HWAN [KR] ET AL) 5 August 2004 (2004-08-05) * abstract * * paragraphs [0013], [0016] - [0021], [0034] - [0048], [0057] - [0060]; figures *	1-6	INV. D06F39/02 D06F39/04 D06F39/08 D06F33/02
X	US 2004/107740 A1 (KIM GON [KR] ET AL) 10 June 2004 (2004-06-10) * the whole document *	1,3-6	
A	----- * the whole document *	2	
X	JP 2002 360984 A (HITACHI LTD) 17 December 2002 (2002-12-17) * abstract; figures *	1,6	
X	JP 2001 157797 A (SANYO ELECTRIC CO) 12 June 2001 (2001-06-12) * abstract; figures 1-3 *	1,2,6	
X	JP 2006 101965 A (MATSUSHITA ELECTRIC IND CO LTD) 20 April 2006 (2006-04-20) * abstract; figures *	1,6	TECHNICAL FIELDS SEARCHED (IPC)
A	DE 82 06 601 U1 (STANDARD ELEKTRIK LORENZ AG) 15 July 1982 (1982-07-15) * the whole document *	3,4	D06F
A	WO 2008/055803 A1 (BSH BOSCH SIEMENS HAUSGERAETE [DE]; SATTLER GUIDO [DE]; ZIEMANN ANDREA) 15 May 2008 (2008-05-15) * the whole document *	3,4	
A	EP 0 582 092 A1 (WHIRLPOOL EUROP [NL]) 9 February 1994 (1994-02-09) * the whole document *	5	
	----- -/--		
The present search report has been drawn up for all claims			
Place of search Munich		Date of completion of the search 12 May 2011	Examiner Prosig, Christina
CATEGORY OF CITED DOCUMENTS X : particularly relevant if taken alone Y : particularly relevant if combined with another document of the same category A : technological background O : non-written disclosure P : intermediate document		T : theory or principle underlying the invention E : earlier patent document, but published on, or after the filing date D : document cited in the application L : document cited for other reasons ..... & : member of the same patent family, corresponding document	

1  
EPO FORM 1503 03.02 (F04C01)



EUROPEAN SEARCH REPORT

Application Number  
EP 11 15 3957

DOCUMENTS CONSIDERED TO BE RELEVANT			
Category	Citation of document with indication, where appropriate, of relevant passages	Relevant to claim	CLASSIFICATION OF THE APPLICATION (IPC)
A	WO 2005/106101 A1 (ARCELIK AS [TR]; OZBEK MEHMET [TR]) 10 November 2005 (2005-11-10) * abstract * * paragraphs [0002], [0030], [0031], [0042]; claim 1; figures * -----	5	
			TECHNICAL FIELDS SEARCHED (IPC)
The present search report has been drawn up for all claims			
Place of search Munich		Date of completion of the search 12 May 2011	Examiner Prosig, Christina
<b>CATEGORY OF CITED DOCUMENTS</b> X : particularly relevant if taken alone Y : particularly relevant if combined with another document of the same category A : technological background O : non-written disclosure P : intermediate document		T : theory or principle underlying the invention E : earlier patent document, but published on, or after the filing date D : document cited in the application L : document cited for other reasons ..... & : member of the same patent family, corresponding document	

1  
EPO FORM 1503 03.82 (PC/MC01)

**ANNEX TO THE EUROPEAN SEARCH REPORT  
ON EUROPEAN PATENT APPLICATION NO.**

EP 11 15 3957

This annex lists the patent family members relating to the patent documents cited in the above-mentioned European search report. The members are as contained in the European Patent Office EDP file on  
The European Patent Office is in no way liable for these particulars which are merely given for the purpose of information.

12-05-2011

Patent document cited in search report	Publication date	Patent family member(s)	Publication date
US 2004148975 A1	05-08-2004	KR 20040047003 A	05-06-2004
US 2004107740 A1	10-06-2004	KR 20040046971 A	05-06-2004
JP 2002360984 A	17-12-2002	JP 3906650 B2	18-04-2007
JP 2001157797 A	12-06-2001	JP 3203245 B2	27-08-2001
JP 2006101965 A	20-04-2006	NONE	
DE 8206601 U1	15-07-1982	NONE	
WO 2008055803 A1	15-05-2008	DE 102006052431 A1	08-05-2008
EP 0582092 A1	09-02-1994	DE 69314409 D1	13-11-1997
		DE 69314409 T2	23-04-1998
		IT MI920693 U1	14-01-1994
WO 2005106101 A1	10-11-2005	NONE	

**REFERENCES CITED IN THE DESCRIPTION**

*This list of references cited by the applicant is for the reader's convenience only. It does not form part of the European patent document. Even though great care has been taken in compiling the references, errors or omissions cannot be excluded and the EPO disclaims all liability in this regard.*

**Patent documents cited in the description**

- JP 2007068801 A [0002] [0003]