

(19)



(11)

EP 2 372 073 A1

(12)

EUROPEAN PATENT APPLICATION

(43) Date of publication:
05.10.2011 Bulletin 2011/40

(51) Int Cl.:
E06B 9/262 (2006.01)

(21) Application number: **10157922.5**

(22) Date of filing: **26.03.2010**

(84) Designated Contracting States:
AT BE BG CH CY CZ DE DK EE ES FI FR GB GR HR HU IE IS IT LI LT LU LV MC MK MT NL NO PL PT RO SE SI SK SM TR

(74) Representative: **Zinkler, Franz Schoppe, Zimmermann, Stöckeler & Zinkler Patentanwälte Postfach 246 82043 Pullach bei München (DE)**

(71) Applicant: **Lin, Shih-Ming Chiayi Hsien (TW)**

Remarks:
Amended claims in accordance with Rule 137(2) EPC.

(72) Inventor: **LIN, Shih-Ming Chiayi-Hsien (TW)**

(54) **Window blind assembly**

(57) A window blind assembly includes a roller blind unit (3), a curtain member unit (4), and a clamping unit (5). The roller blind unit (3) includes a roller rod (32) that extends horizontally and that is rotatably mounted at or in proximity to an upper edge portion of the window (2), and a roller blind cloth (34) a top edge of which is connected to the roller rod (32) and which is able to be wound

around and extended from the roller rod (32). The curtain member unit (4) includes a folding curtain cloth (41) a top edge of which is mounted at or around the upper edge of the window (2). The clamping unit (5) includes a connecting clamp (50) that extends horizontally, and has a first clamping portion (51) that clamps onto the folding curtain cloth (41) and a second clamping portion (52) that clamps onto the roller blind cloth (34).

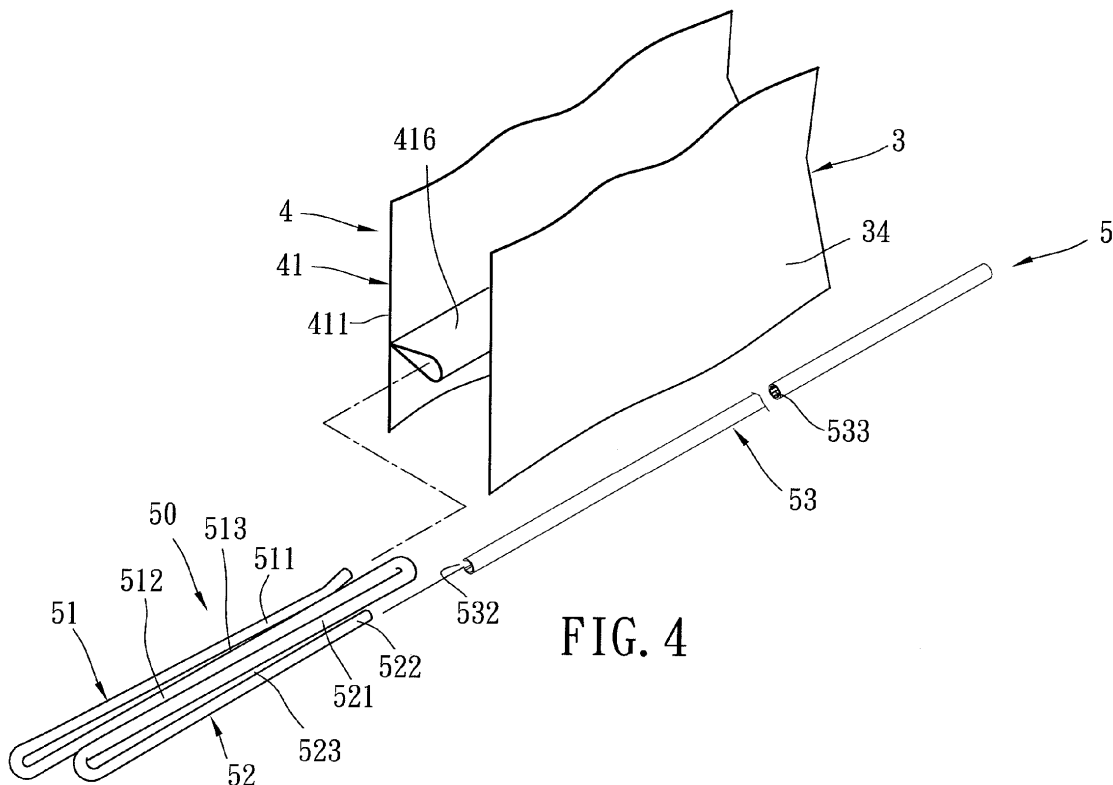

FIG. 4

EP 2 372 073 A1

Description

[0001] The present invention relates to a window blind assembly, more particularly to a window blind assembly that is aesthetically pleasing, structurally simple, and easily taken apart for cleaning.

[0002] There are different types of conventional window blinds, including the roller blind and the roman blind. The conventional roller blind has a roller blind cloth and a roller rod mounted to a window. The roller blind cloth is connected to the roller rod, and may be wound around and unwound from the roller rod by rotating the roller rod, thereby either covering or uncovering the window.

[0003] The roman blind has a curtain cloth mounted to an inner side of a window, and one side of the curtain cloth is provided with some guide rings. Some cords extend through the guide rings, and are then connected to a bottom portion of the curtain cloth. Manipulation of the cords results in folding and unfolding of the curtain cloth.

[0004] However, the conventional roller blind has an unsophisticated appearance. The conventional roman blind, on the other hand, is not easily taken apart for cleaning. There is a need for a new curtain structure that deals with these issues.

[0005] Therefore, the object of the present invention is to provide a window blind assembly, which combines aspects of a roller blind and a roman blind, has a structure that is simple, and is low in cost.

[0006] Accordingly, a window blind assembly of the present invention is adapted for being mounted to a window. The window blind assembly comprises a roller blind unit, a curtain member unit, and a clamping unit.

[0007] The roller blind unit includes a roller rod that extends horizontally and that is rotatably mounted at or in proximity to an upper edge portion of the window, and a roller blind cloth a top edge of which is connected to the roller rod and which is able to be wound around and extended from the roller rod.

[0008] The curtain member unit includes a folding curtain cloth a top edge of which is mounted at or around the upper edge of the window.

[0009] The clamping unit includes a connecting clamp that extends horizontally, and has a first clamping portion that clamps onto the folding curtain cloth and a second clamping portion that clamps onto the roller blind cloth.

[0010] When the roller blind unit is manipulated such that the roller blind cloth is wound around the roller rod, a section of the folding curtain cloth clamped by the first clamping portion of the connecting clamp is displaced upwardly, such that the folding curtain cloth is folded.

[0011] Other features and advantages of the present invention will become apparent in the following detailed description of the preferred embodiments with reference to the accompanying drawings, of which:

Figure 1 is a front perspective view of a window blind assembly according to a first preferred embodiment of the present invention;

Figure 2 is a side view of the window blind assembly of the first preferred embodiment;

Figure 3 is a rear perspective view of the window blind assembly of the first preferred embodiment;

Figure 4 is a fragmentary exploded perspective view of a connecting clamp, a folding curtain cloth, and a roller blind cloth of the first preferred embodiment;

Figure 5 is a view similar to Figure 4, but illustrating an assembly of the connecting clamp, the folding curtain cloth, and the roller blind cloth of the first preferred embodiment in an assembled state;

Figure 6 is view similar to Figure 1, but illustrating a roller blind unit in a partially wound state and the folding curtain cloth in a partially folded state;

Figure 7 is view similar to Figure 6, but illustrating the roller blind unit in a fully wound state and the folding curtain cloth in a fully folded state;

Figure 8 is a view similar to Figure 2, but illustrating the roller blind unit in a fully wound state and the folding curtain cloth a fully folded state; and

Figure 9 is a fragmentary exploded perspective view of the connecting clamp, the folding curtain cloth, and the roller blind cloth according to a second preferred embodiment of the present invention.

[0012] Referring to Figures 1, 2 and 3, a first preferred embodiment of a window blind assembly of the present invention is adapted for being mounted to a window 2. The window blind assembly includes a roller blind unit 3, a curtain member unit 4, and a clamping unit 5 disposed between and interconnecting the roller blind unit 3 and the curtain member unit 4.

[0013] The roller blind unit 3 includes a roller rod 32, a roller blind cloth 34, a horizontal frame 31, a weighting rod 35, and a cord 33.

[0014] The roller rod 32 extends horizontally and is rotatably mounted at or in proximity to an upper edge portion of the window 2.

[0015] The roller blind cloth 34 has a top edge connected to the roller rod 32, and the roller blind cloth 34 is able to be wound around and extended from the roller rod 32.

[0016] The horizontal frame 31 is mounted at least partially surrounding the roller rod 32.

[0017] The weighting rod 35 extends horizontally and is connected to a bottom edge of the roller blind cloth 34. The weighting rod 35 pulls down on the roller blind cloth 34 to flatten the same by virtue of its weight.

[0018] The cord 33 is coupled to the roller rod 32 for controlling rotation of the same such that the roller blind cloth 34 is wound around or extended from the roller rod 32. As described above, the roller blind unit 3 is manipulated by pulling the cord 33 to drive the roller rod 32 such that the roller blind cloth 34 is wound around the roller rod 32 or extended downwardly. During the winding of the roller blind cloth 34 around the roller rod 32, a section of the curtain member unit 4 clamped by the connecting clamp 50 is displaced upwardly, such that the curtain

member unit 4 is folded. This will be described in greater detail below.

[0019] The roller rod 32 may be driven by the cord 33 as described above, or can be driven by a motor (not shown), or can be driven through a spring mechanism (not shown). Therefore, the driving method is not limited to the embodiment described herein. The curtain member unit 4 includes a folding curtain cloth 41, a fastening member 42, and a rod 43.

[0020] The folding curtain cloth 41 has a top edge mounted at or around the upper edge of the window 2, and the folding curtain cloth 41 is disposed in front of the roller blind cloth 34.

[0021] The fastening member 42 interconnects the horizontal frame 31 and the top edge of the folding curtain cloth 41. As an example, the horizontal frame 31 may be made of a fabric material, the fastening member 42 may be a hook fastener, such as that found in a Velcro® fastener, and the fastening member 42 may attach to the fabric material of the horizontal frame 31 through a hook-and-loop engagement with the horizontal frame 31.

[0022] The rod 43 horizontally extends and is connected to a bottom edge of the folding curtain cloth 41.

[0023] In the preferred embodiment, the folding curtain cloth 41 has a sheltering portion 411 and three sleeving portions 416. Each of the sleeving portions 416 extends horizontally, and is connected to a rear surface of the sheltering portion 411 of the folding curtain cloth 41. The sheltering portion 411 has a first cloth segment 412, a second cloth segment 413, a third cloth segment 414, and a fourth cloth segment 415, which are arranged vertically in this order. The sleeving portions 416 horizontally extend, and are respectively disposed at connecting portions between the first cloth segment 412 and the second cloth segment 413, between the second cloth segment 413 and the third cloth segment 414, and between the third cloth segment 414 and the fourth cloth segment 415.

[0024] Referring to Figures 3, 4 and 5, in the preferred embodiment, the clamping unit 5 includes three connecting clamps 50 and three connecting tubes 53. The connecting clamps 50 extend horizontally and are vertically spaced apart from each other.

[0025] In an effort to simplify the discussion to follow immediately below, the structure as it relates only to one of the connecting clamps 50 and one of the connecting tubes 53 will be described.

[0026] The connecting clamp 50 has a first clamping portion 51 that clamps onto the folding curtain cloth 41 and a second clamping portion 52 that clamps onto the roller blind cloth 34.

[0027] The connecting tube 53 extends horizontally on a rear surface of the roller blind cloth 34, and is connected to a respective one of the second clamping portions 52 of the connecting clamps 50. The first clamping portion 51 of the connecting clamp 50 has a front rod 511 and a rear rod 512 which are disposed adjacent to each other and end portions of which are connected to each other. The front rod 511 and the rear rod 512 of the first clamping

portion 51 define a first slot 513 for clamping onto the folding curtain cloth 41. In this embodiment, the front rod 511 of the first clamping portion 51 is inserted into a respective one of the sleeving portions 416, such that the first clamping portion 51 clamps onto the sleeving portion 416.

[0028] The second clamping portion 52 has a front rod 521 and a rear rod 522 disposed adjacent to each other and end portions of which are connected to each other. The front rod 521 and the rear rod 522 of the second clamping portion 52 define a second slot 523 for clamping onto the roller blind cloth 34.

[0029] In this embodiment, the front rod 521 of the second clamping portion 52 is coupled to the rear rod 512 of the first clamping portion 51. In some embodiments, a metal rod can be bent to form the connecting clamp 50. In other embodiments, the connecting clamp 50 can be formed using plastic material. Hence, the present invention is not limited with respect to the material and fabricating method used for the connecting clamp 50.

[0030] The connecting tube 53 is sleeved on the rear rod 522 of the second clamping portion 52 of the connecting clamp 50. End portions of the connecting tube 53 of the clamping unit 5 are formed with slits 532 that extend horizontally and facilitate inserting of the rear rod 522 of the second clamping portion 52 into the connecting tube 53. An inner surface of the connecting tube 53 of the clamping unit 5 is formed with a plurality of lengthwise ribs 533. The ribs 533 are used for enhancing the strength of the connecting tube 53 so as to prevent the same from being bent when in use.

[0031] Referring to Figures 1, 2, and 3, the roller blind cloth 34 of the roller blind unit 3 and the folding curtain cloth 41 of the curtain member unit 4 are respectively unwound and unfolded downwardly when the window 2 is covered. On the other hand, the roller blind cloth 34 of the roller blind unit 3 is wound upwardly by pulling the cord 33 of the roller blind unit 3 which results in rotation of the roller rod 32. When the roller blind cloth 34 is wound around the roller rod 32, the weighting rod 35 moves upwardly to first push against the lowest connecting clamp 50 and the lowest connecting tube 53, and to subsequently displace the lowest connecting clamp 50 and the lowest connecting tube 53 in an upward direction. As a result, the third cloth segment 414 is folded as shown in Figure 6. Referring to Figures 3 and 6, this process is repeated with the continued winding of the roller blind cloth 34, such that the roller blind cloth 34 is fully wound around the roller rod 32, and the second cloth segment 413 and the first cloth segment 412 are eventually folded upwardly as shown in Figures 7 and 8.

[0032] Figures 7 and 8 show that the folded curtain member unit 4 has a sophisticated, classic appearance.

[0033] In the present invention, the roller blind unit 3 is provided with the folding curtain cloth 41 and the clamping unit 5 is mounted between the curtain member unit 4 and the roller blind unit 3. Hence, the result is a style resembling a roman blind, a structure that allows for

mounting that is simple, and an overall design in which the cost thereof is reduced.

[0034] Referring to Figures 1, 2, and 4, the folding curtain cloth 41 uses the fastening member 42 for attachment to the horizontal frame 31. Accordingly, by simply removing the fastening member 42 and the connecting clamps 50, the folding curtain cloth 41 can be removed for cleaning or for replacement with another folding curtain cloth 41 with a different style. In addition, the slit 532 of the connecting tube 53 of the clamping unit 5 allows for convenient insertion of the rear rod 522 of the connecting clamp 50 into the connecting tube 53.

[0035] Figure 9 illustrates a second preferred embodiment of the window blind assembly according to the present invention. The second preferred embodiment differs from the first preferred embodiment in the following aspects.

[0036] The connecting tube 53 of each of the connecting clamps 50 extends into a respective one of the sleeving portions 416, and is sleeved on the front rod 511 of the first clamping portion 51 of the corresponding connecting clamp 50. During the process of being folded upwardly, the connecting tube 53 can horizontally support the folding curtain cloth 41.

Claims

1. A window blind assembly adapted for being mounted to a window (2), **characterized by:**

a roller blind unit (3) including a roller rod (32) that extends horizontally and that is rotatably mounted at or in proximity to an upper edge portion of the window (2), and a roller blind cloth (34) a top edge of which is connected to said roller rod (32) and which is able to be wound around and extended from said roller rod (32); a curtain member unit (4) including a folding curtain cloth (41) a top edge of which is mounted at or around the upper edge of the window (2); and

a clamping unit (5) including a connecting clamp (50) that extends horizontally, and has a first clamping portion (51) that clamps onto said folding curtain cloth (41) and a second clamping portion (52) that clamps onto said roller blind cloth (34);

when said roller blind unit (3) is manipulated such that said roller blind cloth (34) is wound around said roller rod (32), a section of said folding curtain cloth (41) clamped by said first clamping portion (51) of said connecting clamp (50) is displaced upwardly, such that said folding curtain cloth (51) is folded.

2. The window blind assembly as claimed in claim 1, **characterized in that** said roller blind unit (3) further

includes a horizontal frame (31) that is mounted at least partially surrounding said roller rod (32), and said curtain member unit (4) further includes a fastening member (42) that interconnects said horizontal frame (31) and said top edge of said folding curtain cloth (41).

3. The window blind assembly as claimed in claim 1, **characterized in that** said curtain member unit (4) further includes a rod (43) that horizontally extends and is connected to a bottom edge of said folding curtain cloth (41).

4. The window blind assembly as claimed in claim 1, **characterized in that:**

said first clamping portion (51) of said connecting clamp (50) has a front rod (511) and a rear rod (512) disposed adjacent to each other and which define a first slot (513) for clamping onto said folding curtain cloth (41); and said second clamping portion (52) has a front rod (521) and a rear rod (522) disposed adjacent to each other and which define a second slot (523) for clamping onto said roller blind cloth (34), said front rod (521) of said second clamping portion (52) being coupled to said rear rod (512) of said first clamping portion (51) .

5. The window blind assembly as claimed in claim 4, **characterized in that** said clamping unit (5) further includes a connecting tube (53) which extends horizontally on a rear surface of said roller blind cloth (34), said connecting tube (53) being sleeved on said rear rod (522) of said second clamping portion (52) of said connecting clamp (50).

6. The window blind assembly as claimed in claim 4, **characterized in that** said curtain member unit (4) further includes a sleeving portion (416) that extends horizontally, and is connected to a rear surface of said folding curtain cloth (41), said front rod (511) of said first clamping portion (51) of said connecting clamp (50) being inserted into said sleeving portion (416).

7. The window blind assembly as claimed in claim 5, **characterized in that** end portions of said connecting tube (53) of said clamping unit (5) are formed with slits (532) that extend horizontally and facilitate inserting of said rear rod (522) of said second clamping portion (52) into said connecting tube (53).

8. The window blind assembly as claimed in claim 5, **characterized in that** an inner surface of said connecting tube (53) of said clamping unit (5) is formed with a lengthwise rib (533).

9. The window blind assembly as claimed in claim 6, **characterized in that** said clamping unit (5) further includes a connecting tube (53) which extends into said sleeving portion (416), said connecting tube (53) being sleeved on said front rod (511) of said first clamping portion (51) of said connecting clamp (50). 5
10. The window blind assembly as claimed in claim 1, **characterized in that** said clamping unit (5) further includes a connecting tube (53) which extends horizontally on a rear surface of said roller blind cloth (34), said connecting tube (53) being connected to said second clamping portion (52) of said connecting clamp (50). 10
11. The window blind assembly as claimed in claim 1, **characterized in that** said roller blind unit (3) further includes a weighting rod (35) that extends horizontally and that is connected to a bottom edge of said roller blind cloth (34). 15
12. The window blind assembly as claimed in claim 1, **characterized in that** said roller blind unit (3) further includes a cord (33) coupled to said roller rod (32) for controlling rotation of the same such that said roller blind cloth (34) is wound around or extended from said roller rod (32). 20

Amended claims in accordance with Rule 137(2) EPC. 30

1. A window blind assembly adapted for being mounted to a window (2), **characterized by:**

a roller blind unit (3) including a roller rod (32) that extends horizontally and that is rotatably mounted at or in proximity to an upper edge portion of the window (2), a roller blind cloth (34) a top edge of which is connected to said roller rod (32) and which is able to be wound around and extended from said roller rod (32), and a weighting rod (35) that extends horizontally and that is connected to a bottom edge of said roller blind cloth (34); 35

a curtain member unit (4) including a folding curtain cloth (41) a top edge of which is mounted at or around the upper edge of the window (2); and 40

a clamping unit (5) including a connecting clamp (50) that extends horizontally, and that has a first portion (51) clamping onto said folding curtain cloth (41) and a second portion (52) formed with a slot (523) allowing said roller blind cloth (34) to extend therethrough; 45

said roller blind unit (3) being operable to wind said roller blind cloth (34) around said roller rod (32), thereby displacing said roller blind cloth

(34) upwardly with respect to said slot (523) in said second portion (52), and moving said weighting rod (35) toward said connecting clamp (50) so as to upwardly displace said connecting clamp (50) and a section of said folding curtain cloth (41) clamped by said first portion (51) of said connecting clamp (50) to result in folding of said folding curtain cloth (41).

2. The window blind assembly as claimed in claim 1, **characterized in that** said roller blind unit (3) further includes a horizontal frame (31) that is mounted at least partially surrounding said roller rod (32), and said curtain member unit (4) further includes a fastening member (42) that interconnects said horizontal frame (31) and said top edge of said folding curtain cloth (41). 10

3. The window blind assembly as claimed in claim 1, **characterized in that** said curtain member unit (4) further includes a rod (43) that horizontally extends and is connected to a bottom edge of said folding curtain cloth (41). 15

4. The window blind assembly as claimed in claim 1, **characterized in that:**

said first portion (51) of said connecting clamp (50) has a front rod (511) and a rear rod (512) disposed adjacent to each other and which define a clamping slot (513) for clamping onto said folding curtain cloth (41); and 20

said second portion (52) has a front rod (521) and a rear rod (522) disposed adjacent to each other and which define said slot (523), said front rod (521) of said second portion (52) being coupled to said rear rod (512) of said first portion (51). 25

5. The window blind assembly as claimed in claim 4, **characterized in that** said clamping unit (5) further includes a connecting tube (53) which extends horizontally on a rear surface of said roller blind cloth (34), said connecting tube (53) being sleeved on said rear rod (522) of said second portion (52) of said connecting clamp (50). 30

6. The window blind assembly as claimed in claim 4, **characterized in that** said curtain member unit (4) further includes a sleeving portion (416) that extends horizontally, and is connected to a rear surface of said folding curtain cloth (41), said front rod (511) of said first portion (51) of said connecting clamp (50) being inserted into said sleeving portion (416). 35

7. The window blind assembly as claimed in claim 5, **characterized in that** end portions of said connecting tube (53) of said clamping unit (5) are formed

with slits (532) that extend horizontally and facilitate inserting of said rear rod (522) of said second portion (52) into said connecting tube (53).

8. The window blind assembly as claimed in claim 5, **characterized in that** an inner surface of said connecting tube (53) of said clamping unit (5) is formed with a lengthwise rib (533). 5

9. The window blind assembly as claimed in claim 6, **characterized in that** said clamping unit (5) further includes a connecting tube (53) which extends into said sleeving portion (416), said connecting tube (53) being sleeved on said front rod (511) of said first portion (51) of said connecting clamp (50). 10 15

10. The window blind assembly as claimed in claim 1, **characterized in that** said clamping unit (5) further includes a connecting tube (53) which extends horizontally on a rear surface of said roller blind cloth (34), said connecting tube (53) being connected to said second portion (52) of said connecting clamp (50). 20

11. The window blind assembly as claimed in claim 1, **characterized in that** said roller blind unit (3) further includes a cord (33) coupled to said roller rod (32) for controlling rotation of the same such that said roller blind cloth (34) is wound around or extended from said roller rod (32). 25 30

35

40

45

50

55

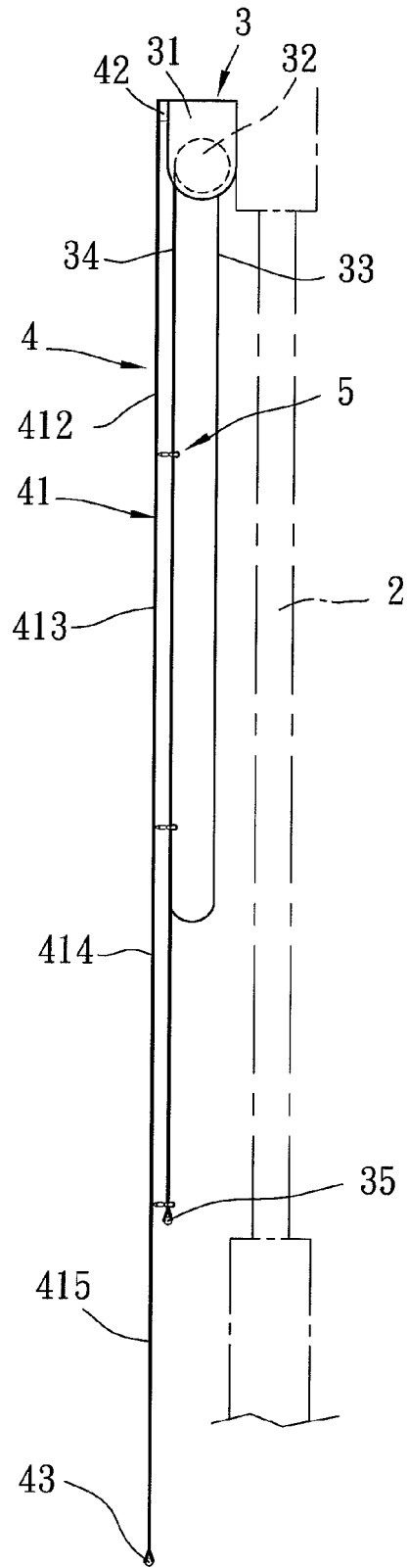
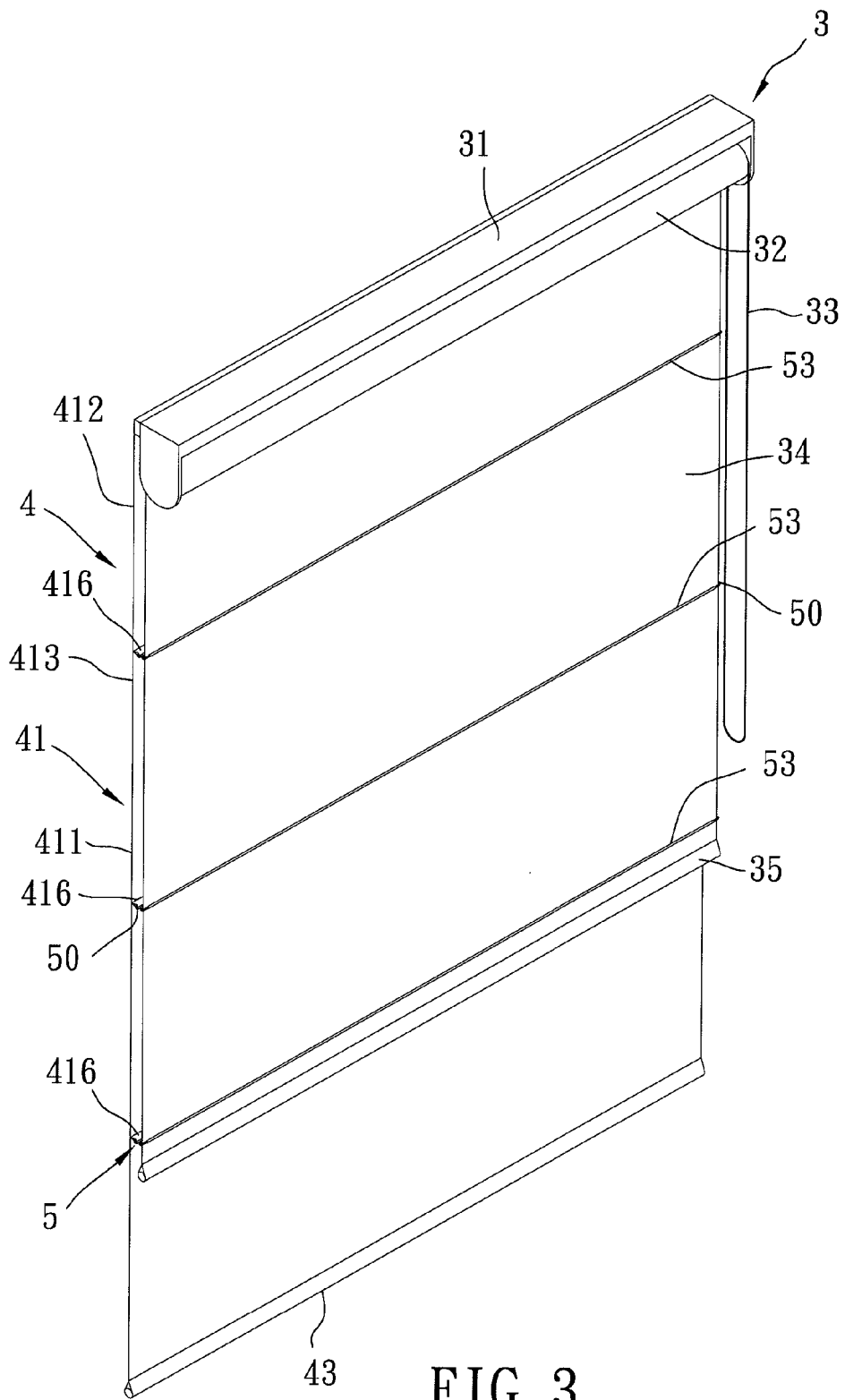
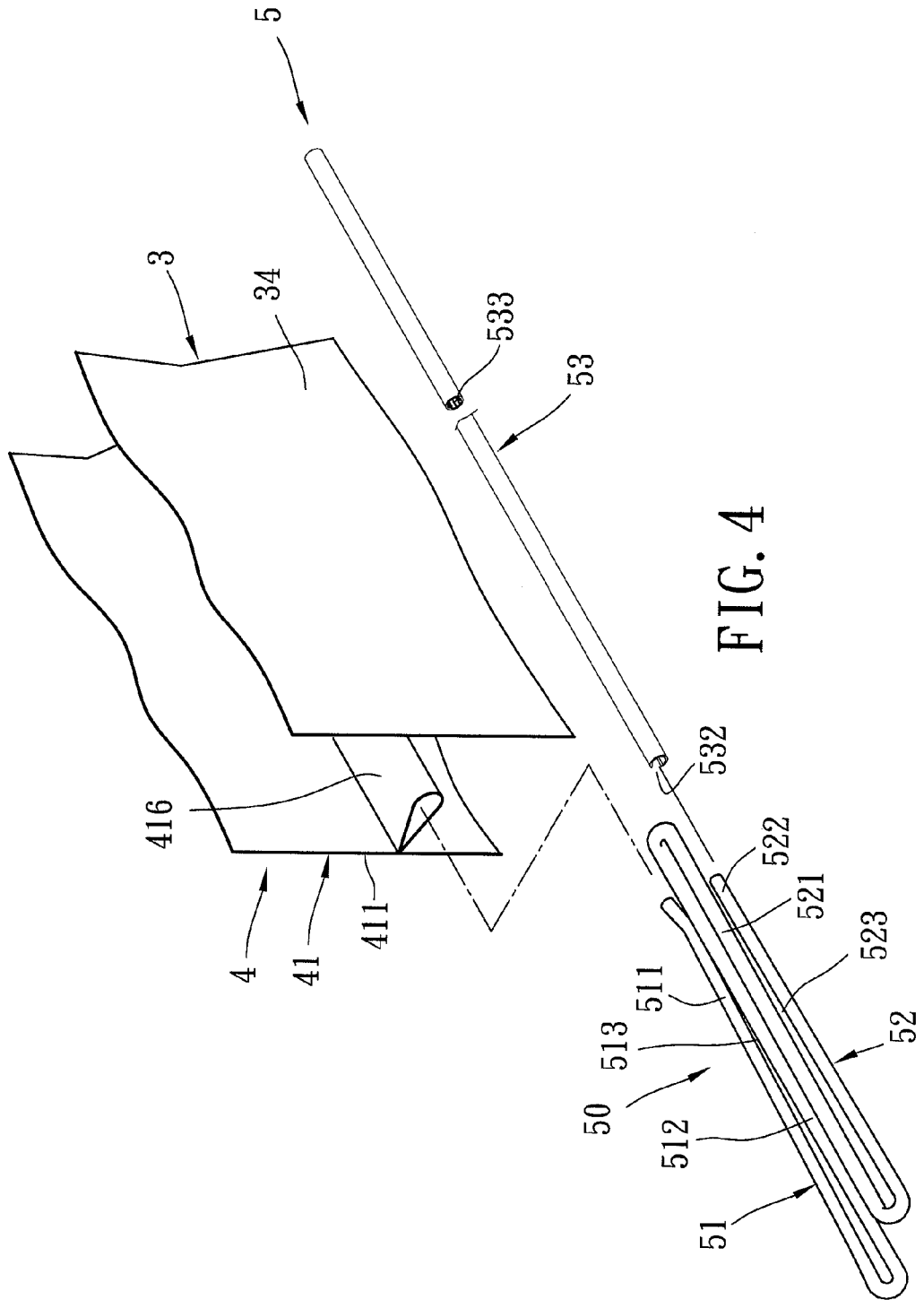

FIG. 2





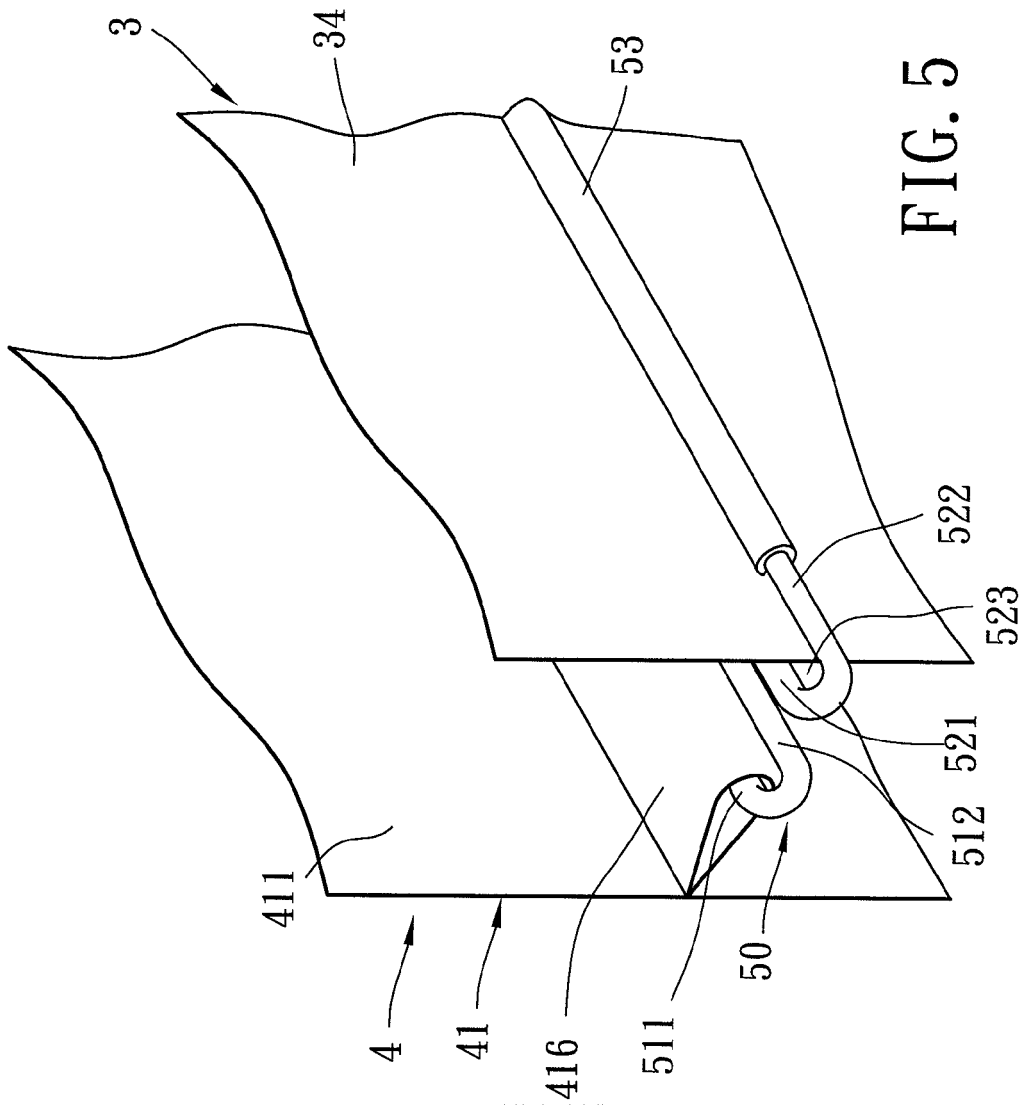

FIG. 5

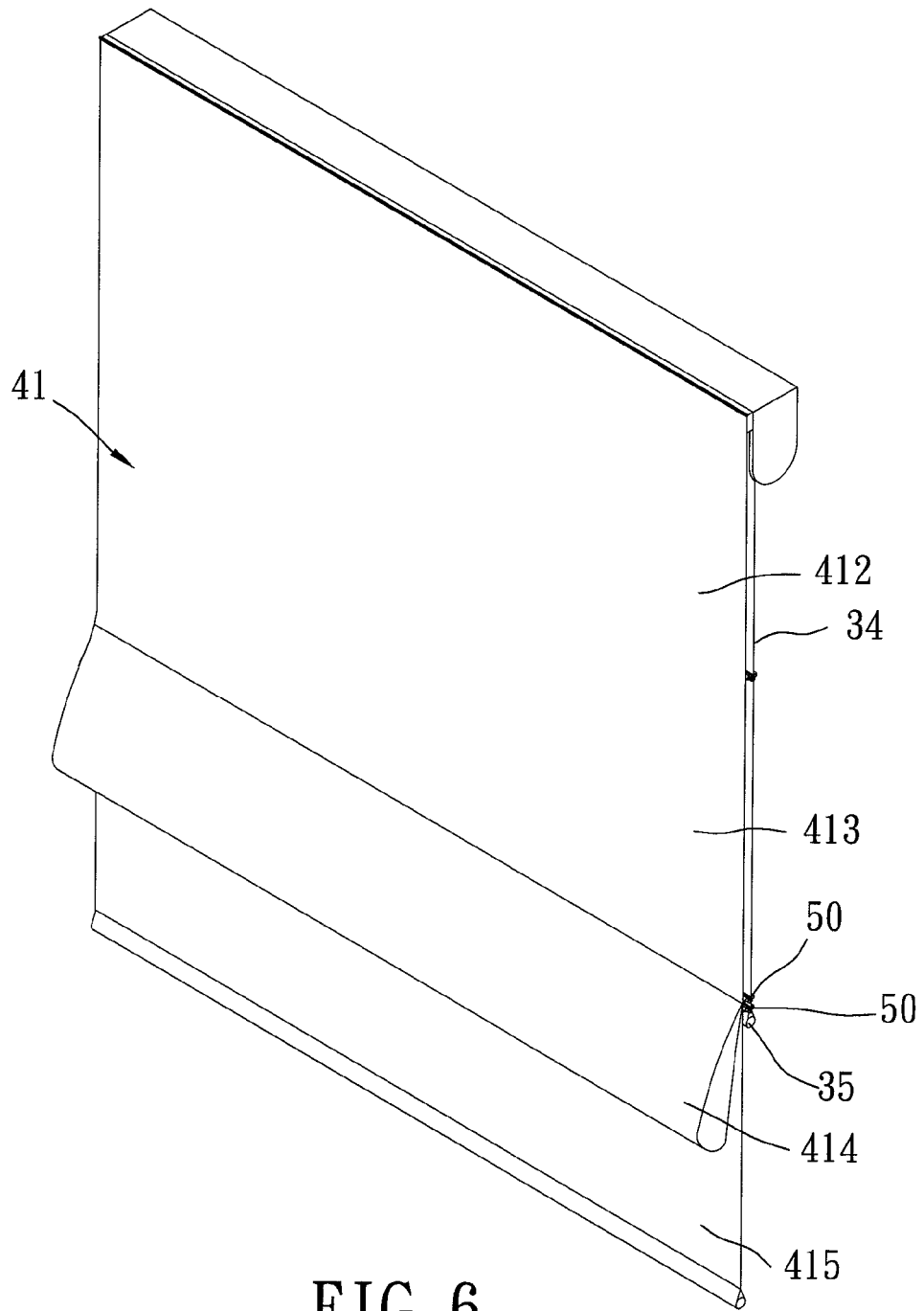

FIG. 6

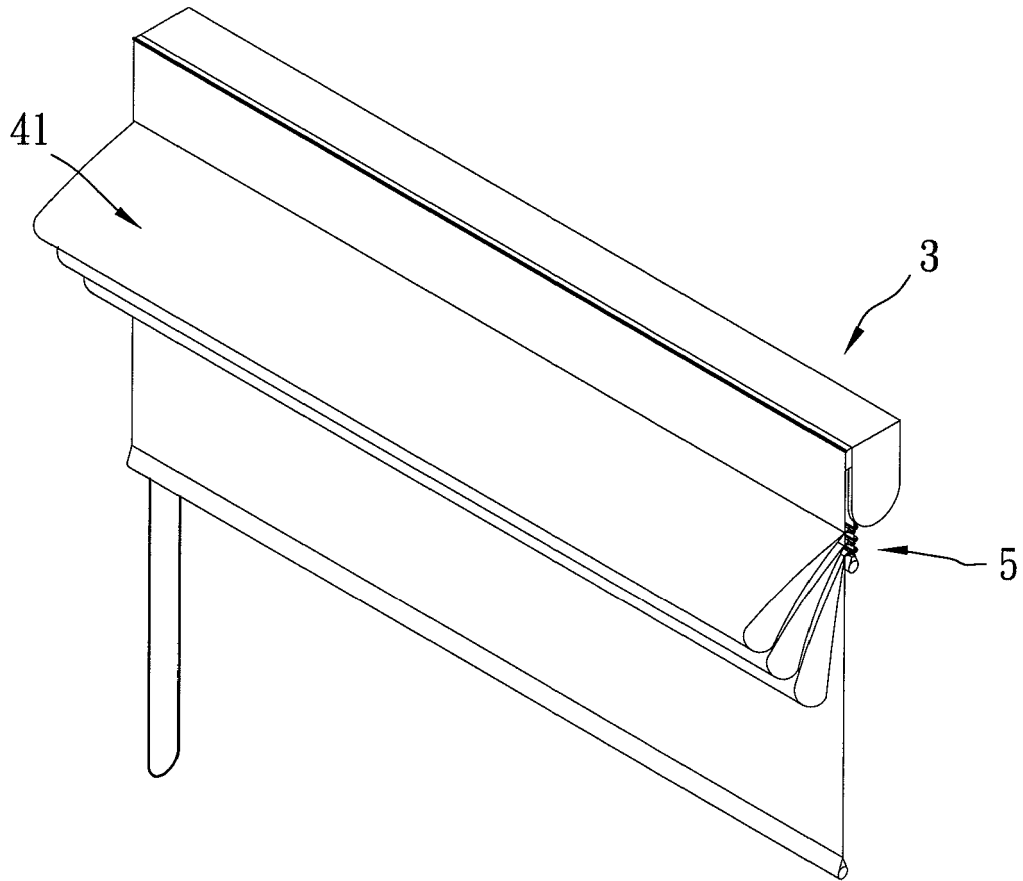

FIG. 7

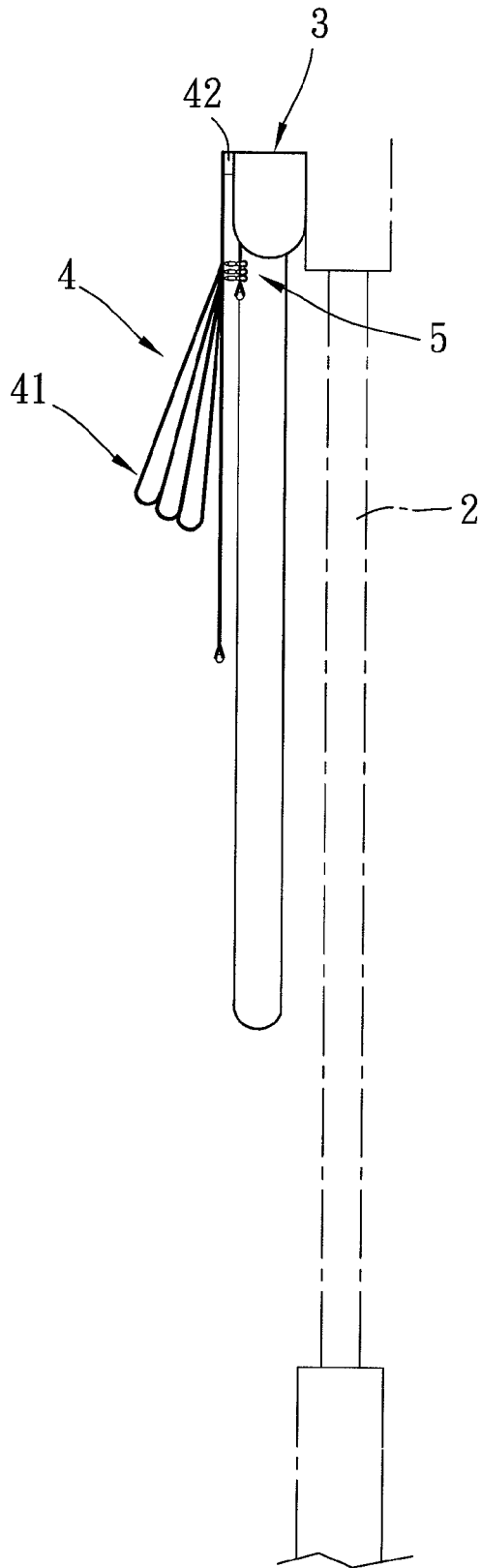

FIG. 8

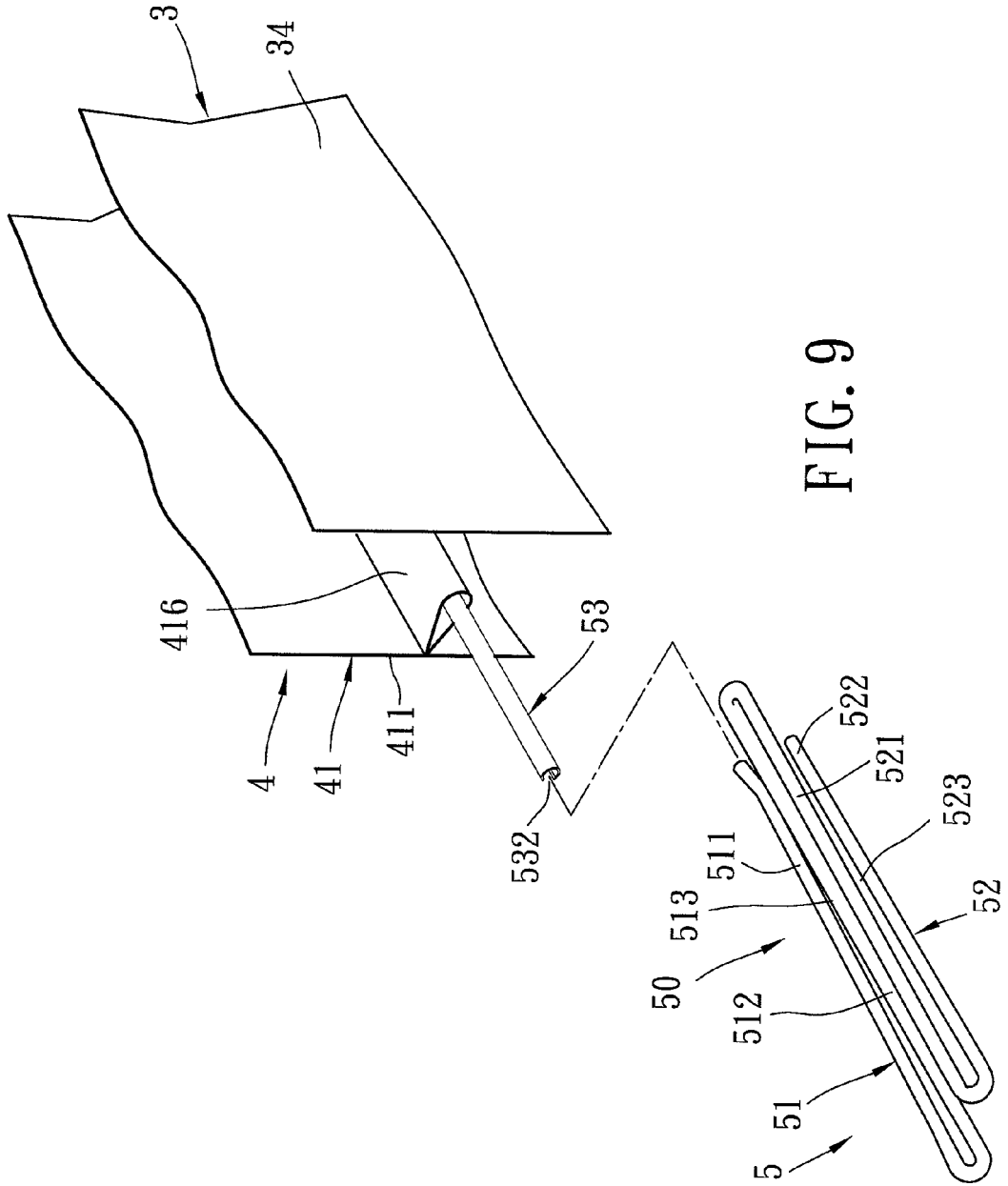

FIG. 9



EUROPEAN SEARCH REPORT

Application Number
EP 10 15 7922

DOCUMENTS CONSIDERED TO BE RELEVANT			
Category	Citation of document with indication, where appropriate, of relevant passages	Relevant to claim	CLASSIFICATION OF THE APPLICATION (IPC)
A	GB 2 389 074 A (LOUVER LITE LTD [GB]) 3 December 2003 (2003-12-03) * the whole document * -----	1-12	INV. E06B9/262
A	FR 2 203 013 A1 (QUIOT ANDRE [FR]) 10 May 1974 (1974-05-10) * the whole document * -----	1-12	
A	GB 1 461 395 A (BEAUTY BLINDS LTD) 13 January 1977 (1977-01-13) * the whole document * -----	1-12	
			TECHNICAL FIELDS SEARCHED (IPC)
			A47H E06B
The present search report has been drawn up for all claims			
Place of search		Date of completion of the search	Examiner
The Hague		21 October 2010	Cornu, Olivier
CATEGORY OF CITED DOCUMENTS		T : theory or principle underlying the invention E : earlier patent document, but published on, or after the filing date D : document cited in the application L : document cited for other reasons & : member of the same patent family, corresponding document	
X : particularly relevant if taken alone Y : particularly relevant if combined with another document of the same category A : technological background O : non-written disclosure P : intermediate document			

6
EPO FORM 1503 03.82 (P04C01)

**ANNEX TO THE EUROPEAN SEARCH REPORT
ON EUROPEAN PATENT APPLICATION NO.**

EP 10 15 7922

This annex lists the patent family members relating to the patent documents cited in the above-mentioned European search report. The members are as contained in the European Patent Office EDP file on The European Patent Office is in no way liable for these particulars which are merely given for the purpose of information.

21-10-2010

Patent document cited in search report	Publication date	Patent family member(s)	Publication date
GB 2389074	A	03-12-2003	AU 2003204246 A1 18-12-2003
			CA 2429280 A1 30-11-2003
			IE 20030375 A1 10-12-2003
			US 2004020604 A1 05-02-2004

FR 2203013	A1	10-05-1974	NONE

GB 1461395	A	13-01-1977	NONE

EPO FORM P0459

For more details about this annex : see Official Journal of the European Patent Office, No. 12/82