



(11) **EP 2 374 733 B1**

(12) **EUROPEAN PATENT SPECIFICATION**

(45) Date of publication and mention of the grant of the patent:
31.10.2012 Bulletin 2012/44

(51) Int Cl.:
B65D 85/804^(2006.01)

(21) Application number: **10425100.4**

(22) Date of filing: **30.03.2010**

(54) **Capsule or pod for the production of an infused drink**

Kapsel oder Pod zur Herstellung eines Brühgetränks

Capsule ou dosette pour la production d'une boisson infusée

(84) Designated Contracting States:
AT BE BG CH CY CZ DE DK EE ES FI FR GB GR HR HU IE IS IT LI LT LU LV MC MK MT NL NO PL PT RO SE SI SK SM TR

(43) Date of publication of application:
12.10.2011 Bulletin 2011/41

(73) Proprietor: **Capitani S.r.l.**
22070 Solbiate (CO) (IT)

(72) Inventor: **Capitani, Emilio**
22070 Albiolo
Como (IT)

(74) Representative: **Chimini, Francesco et al**
Jacobacci & Partners S.p.A.
Piazza della Vittoria 11
25122 Brescia (IT)

(56) References cited:
WO-A1-2007/114685 GB-A- 1 256 247

EP 2 374 733 B1

Note: Within nine months of the publication of the mention of the grant of the European patent in the European Patent Bulletin, any person may give notice to the European Patent Office of opposition to that patent, in accordance with the Implementing Regulations. Notice of opposition shall not be deemed to have been filed until the opposition fee has been paid. (Art. 99(1) European Patent Convention).

Description

[0001] The present invention relates to a capsule, a pod or the like usable in a machine for the production of an infused drink.

[0002] It is known to use machines dispensing infused drinks, such as coffee, which for such purpose use single dose capsule or pods containing an aromatic essence for making the relative drinks.

[0003] Such machines usually present at least one perforator element associated with the infusion group, which penetrates the compartment delimited by the capsule where the aromatic essence is contained, so as to place the latter in connection with an infusor fluid.

[0004] However, the devices of the prior art suffer a plurality of drawbacks.

[0005] In particular, the perforator element of the known machines comes into contact with a plurality of different capsules/essences, contaminating the taste of a subsequent capsule with the taste of the previous one.

[0006] Furthermore, it is not infrequent for dirt to build up and/or bacteria to form on the perforator element, thereby making the subsequently dispensed infused drinks insalubrious.

[0007] In such regard, to attempt to overcome these drawbacks, the aforesaid machines have been provided with systems for cleaning and hygienising the perforator element. Such measure however entails a dramatic increase in the design costs for the machine manufacturers, and in the cost of the product to the end users.

[0008] Capsules with perforation means as in the preamble of appended claim 1 are also known from GB 1256247 A and WO 2007/114685 A1.

[0009] The present invention therefore sets out to supply an economical system for the perforation of capsules containing aromatic essences, which does not cause contamination phenomena of the subsequent capsule, for example having a different fragrance, and which does not require use of a cleaning and sterilisation system.

[0010] Such purpose is achieved by a capsule according to claim 1, and by an assembly according to claim 15. The dependent claims show preferred embodiments.

[0011] The present invention will now be described in detail, with the help of the attached drawings, wherein:

[0012] - figure 1 shows a capsule which the present invention relates to in an initial configuration according to one possible embodiment, positioned inside an infusion group;

[0013] - figure 2 shows the capsule in figure 1 in an infusion configuration.

[0014] With reference to the mentioned drawings reference numeral 1 globally indicates a capsule, pod or the like, suitable for cooperating with the infusion group 2, 4 of a machine for the production of an infused drink.

[0015] According to one embodiment variation, the infusion group 2, 4 usable with the capsule 1 of the invention, comprises a male infusor 2 and a female infusor 4, which are preferably reciprocally mobile.

[0016] For example, in the variation shown in figure 1, the male infusor 2, preferably in the form of an infusor pin, is movable in relation to the female infusor 4 along the direction shown by arrow 30.

5 **[0017]** The capsule 1 comprises a side wall 6 and at least one end wall 8', 8", reciprocally connected so as to delimit a containment compartment 12 of at least one aromatic essence, such as coffee.

[0018] Consequently, the aromatic essence is enclosed inside the compartment 12 by the side wall 6 and by the end wall 8', 8", preferably in an airtight manner

[0019] This way accidental spillage of the aromatic essence from the capsule 1 is prevented and the fragrance of the essence, and thereby of the infused drink, is preserved better over time.

15 **[0020]** Within the text of this patent "aromatic essence" is taken to mean a substance suitable for transferring an aroma to a liquid infusor, such as water or milk.

[0021] By way of a non-limiting example, the aromatic essence according to the present invention is suitable for generating coffee, tea, camomile and similar, fruit, vegetable or chocolate flavoured drinks, or blends thereof.

20 **[0022]** According to one advantageous embodiment, the side wall 6 extends around a longitudinal axis X, delimiting a substantially tubular containment compartment 12.

25 **[0023]** Preferably, the capsule 1 comprises a first 8' and a second 8" end wall, which are reciprocally distanced along the side wall 6.

30 **[0024]** In other words, according to the two previous variations, the first 8' and the second 8" end walls are positioned at the axial extremities of the side wall 6.

35 **[0025]** According to one embodiment variation, the capsule 1 comprises means for blocking itself inside the infusion group 2, 4, so that the capsule 1 is retained in a desired position.

[0026] In the variation shown in the drawings, the means for blocking comprise a peripheral crown 32, suitable for engaging an engagement seat 34 of the infusion group 2, 4.

40 **[0027]** This way uncontrolled movement of the capsule 1 inside the infusion group 2, 4 is prevented.

[0028] In other words, the peripheral crown 32 consists of a portion of the capsule 1 projecting radially outwardly in relation to the side wall 6, i.e. directed in the opposite direction to the containment compartment 12.

[0029] At least one between the side wall 6 and the end wall 8', 8" comprises at least one perforable portion 10 to make a fluidic connection between the containment compartment 12 and the infusion group 2, 4 so as to obtain the infused drink.

45 **[0030]** As a result, the perforable portion 10 is suitable for preventing/allowing fluidic connection between the containment compartment 12 and the infusion group 2, 4.

[0031] In other words, as long as the perforable portion 10 is in a substantially intact configuration, the aforesaid fluidic connection is prevented, in that the containment

compartment 12 is inaccessible to an infusor fluid flowing through the infusion group.

[0032] Vice versa, after the perforable portion 10 has been perforated, such connection is allowed and hence contact between the infusor fluid, preferably water, steam or a mixture of the two, and the aromatic essence is allowed so as to obtain the infused drink.

[0033] In other words, the breakage of the perforable portion 10 removes the fluidic barrier between the compartment 12 and the infusion group 2, 4.

[0034] Preferably, the perforable portion 10 is positioned at the end wall 8', 8" and, even more preferably, such portion 10 is substantially coincident with such wall 8', 8".

[0035] The capsule 1 further comprises at least one perforating device, operatively connected to the perforable portion 10 and suitable for cooperating with the infusion group 2, 4 to create the fluidic connection.

[0036] Consequently, the perforating device of the capsule 1 is suitable for interacting with the perforable portion 10 to realise the fluidic connection through the action of the infusion group 2, 4.

[0037] In other words, the perforating device is shaped in such a manner as to traverse the perforable portion 10 to enable entry of the infusor fluid in the containment compartment 12 and/or the emission of the infused drink from such compartment 12.

[0038] According to a variation not shown, when the perforating device performs the breach in the perforable portion 10, the aforesaid entry and the aforesaid emission take place on the same part or same side of the of the capsule 1.

[0039] Preferably, the perforating device is movable by the infusion group 2, 4 so that a portion of the former traverses the perforable portion 10.

[0040] In other words, the infusion group 2, 4 is suitable for moving the perforating device through the perforable portion 10.

[0041] Preferably, the perforating device is suitable for being activated by a thrust component 2 of the infusion group 2, 4 which, in the variations shown, is composed of the infusor pin.

[0042] The perforating device is movable in relation to the side wall 6 or end wall 8', 8" between an initial configuration, wherein the perforable portion 10 is substantially intact, and an infusion configuration, wherein said device at least partially traverses the thickness of the perforable portion 10.

[0043] In other words, during transition between the initial configuration and the infusion configuration, the perforating device is moved along a direction of movement, preferably parallel to the axis X, in relation to the side wall 6, preferably so that a portion 18 of such device completely traverses the containment compartment 12.

[0044] In still other words, the perforating device is thrust into the containment compartment 12 on one side of the capsule (such as on the side of the first end wall 8' in the drawings) so that a portion of the former comes

out on the opposite side of the capsule 1 (that is on the side of the second end wall 8").

[0045] This way the portion 18 of such device causes the perforation of the perforable portion 10.

[0046] Consequently, the longitudinal extension of the perforating device is preferably greater than that of the side wall 6.

[0047] According to a further variation, the longitudinal extension of the perforating device is inferior to that of the side wall 6. In such case, the capsule 1 is shaped in such a way as to receive at least a portion of the infusion group, preferably a portion of the thrust component.

[0048] According to such variation, the portion of the infusion group which penetrates the capsule 1 thereby compensates the lacking length of the perforating device.

[0049] Advantageously, the perforating device comprises an abutment surface 16 with a component of the infusion group 2, 4, fixed or mobile, and comprises furthermore a perforation portion 18, opposite the abutment surface 16, suitable for traversing the perforable portion 10.

[0050] Consequently, the abutment surface 16 and the perforation portion 18 are distanced so that the former 16 acts as an abutment surface for the component of the infusion group 2, 4, and the latter 18 traverses the perforable portion 10, when the perforating device is moved towards the infusion configuration.

[0051] Preferably, the perforating device extends along the longitudinal axis X which is advantageously the same axis around which the side wall 6 extends according to a preferred variation of the invention.

[0052] Consequently, according to the aforesaid variation, the perforating device and the side wall 6 are reciprocally positioned coaxially in relation to the longitudinal axis X.

[0053] In other words, the perforating device is positioned inside the containment compartment 12 in such a way as to delimit, with the side wall 6, a substantially toroidal-shaped containment compartment 12.

[0054] Preferably, the perforation portion 18 of the perforating device comprises a bevel-cut end.

[0055] Even more preferably, such cut end has a plurality of sections, each corresponding to a different cutting plane, and the section furthest from the tip of the perforation portion 18 has a cutting plane with a slope, or with an average slope, greater in relation to the longitudinal axis X than that/those of the other cutting planes which define the other sections.

[0056] According to a particularly advantageous embodiment, the perforating device comprises a hollow pin, in fluidic communication with the containment compartment 12, at least at the perforation portion 18.

[0057] Thereby, when the perforation portion 18 traverses the thickness of the perforable portion 10 (e.g. as shown in figure 2), the hollow mouth 36 of the aforesaid pin facilitates the entrance of the infusor fluid in the compartment 12 and/or the emission of the infused drink from

the containment compartment 12.

[0058] The capsule 1 comprises a support portion 20 for the perforating device, connected to the side wall 6 or to the end wall 8', 8" and which extends from at least one of them 6, 8', 8".

[0059] Consequently, when the perforating device is moved between the described configurations, the support portion 20 is shaped so as to prevent the device from inclining or positioning itself in a conformation unsuitable for traversing the perforable portion 10.

[0060] In other words, the support portion 20 acts as a guide for the movement, and preferably for the translation, of the perforating device .

[0061] In the variation shown, the support portion 20 for the perforating device extends from the first end wall 8' towards the containment compartment 12.

[0062] According to a further variation, the support portion 20 for the perforating device extends from the side wall 6 or from the end wall 8', 8" in the opposite direction to the containment compartment 12.

[0063] According to a particularly advantageous variation, the support portion 20 delimits an annular cavity 22 with the perforating device, suitable for receiving the infusor fluid.

[0064] In other words, the annular cavity 22 delimits a passage with a sufficient cross section to be traversed by the infusor fluid.

[0065] The perforating device is at least partially connected to the support portion 20, advantageously to one end 20' of such portion 20, by means of a tearing portion 24 which, when torn, allows fluidic connection.

[0066] Consequently, such variation allows the infusor fluid to enter from a first side of the capsule 1 into the containment compartment, in the present case from the same side as the first wall 8', and further allows the infused drink to come out of the opposite side of the capsule 1.

[0067] According to one variation, the laceration of the tearing portion 24 occurs at least partially simultaneously to the conversion of the perforating device from the initial configuration to that of infusion.

[0068] Consequently, when the perforating device is moved from the initial configuration to that of infusion, two entries to the containment compartment 12 are opened; the first one through the action of the portion 18 of the perforating device on the perforable portion, the second one through the partial laceration of the tearing portion 24.

[0069] According to the variation shown in figure 2, after breakage of the portion 24, the infusor fluid passes through a component of the infusion group 2, 4 in the direction of the arrow 40, flows through the mouth 38 into the annular cavity 22, coming out in the containment compartment 12. Lastly, after the infusion of the infusor fluid and the aromatic essence, the infused drink comes out of the aperture 42 made by the perforating device in the second end wall 8".

[0070] According to one advantageous variation, the

tearing portion 24 comprises a sealing ring 26 which extends between the perforating device and the support portion 20.

[0071] Preferably, such ring 26 has a variable radial section and, in particular, radially decreasing section, for example wedge-shaped.

[0072] This way, the sealing ring 26 constitutes a preferential tearing zone between the perforating device and the support portion 20.

[0073] According to a particularly advantageous variation, the capsule 1 further comprises flow diverting means, suitable for increasing residence time of an infusor fluid in the containment compartment 12.

[0074] In other words, the flow diverting means are suitable for making the infusor fluid flow into the capsule 1, so as to increase the contact time of the infusor fluid with the aromatic essence.

[0075] In other words again, the flow diverting means prevent the infusor fluid from passing inside the containment compartment 12 at such a speed as to prevent correct infusion.

[0076] For example, with reference to figure 2, the arrows 46, 48 show the route which the infusor fluid coming from the annular cavity 22 presumably takes through the containment compartment 12.

[0077] Preferably, the diverting means comprise the sealing ring 26.

[0078] As a result, for the variations which envisage this component, the sealing ring 26 performs a plurality of functions.

[0079] In particular, as long as the perforating device is positioned in the initial configuration, the sealing ring 26 ensures that such device remains joined to the side wall 6 or to the end wall 8', 8", closing the containment compartment 12, preferably in an airtight manner.

[0080] Furthermore, the sealing ring 26 ensures that the detachment of the perforating device from the side wall 6 or from the end wall 8', 8" takes place in a suitably localised area.

[0081] Lastly, when the perforating device is in the infusion configuration, the sealing ring 26 acts as a flow diverter for the infusor fluid entering the capsule.

[0082] The present invention furthermore relates to an assembly 28 comprising an infusion group 2, 4 of a machine for the production of an infused drink, and a capsule 1 according to any of the embodiments described above, engaged in the infusion group 2, 4.

[0083] Preferably, the infusion group 2, 4 comprises an infusor pin 2 suitable for abutting in an airtight manner against the end wall 8', 8" of the capsule 1.

[0084] In other words, the infusor pin 2 comprises a sealing element 44 suitable for abutting with the end wall 8', 8" of the capsule 1, so as to ensure that the infusor fluid coming out of the infusor pin 2 is guided, preferably without leakage of any kind, into the containment compartment 12, in the manner shown above.

[0085] Innovatively, the capsule which the present invention relates to makes it possible to preserve the indi-

vidual fragrance of each aromatic essence, preventing contamination phenomena of the subsequent capsules.

[0086] In fact, each infused drink has its own different perforating device, previously unused.

[0087] Furthermore, the capsule which the present invention relates to makes it possible to prevent the build up of dirt on the perforating device, further averting the creation and proliferation of bacteria colonies which could prove injurious to health.

[0088] This way, special sterilisation devices which would add to the cost and complexity of the dispenser machines are rendered superfluous.

[0089] In other words, the capsule which the present invention relates to makes it possible to renew the perforating device at each infusion.

[0090] Advantageously, the capsule which the present invention relates to is suitable for positioning itself inside the infusion group in a desired position so that the infusion operation and/or release of the used capsule occurs in a highly repeatable manner.

[0091] Advantageously, in the capsule of the present invention, the suture between the side wall and the end wall is made over a large surface area so as to prevent accidental detachment of such walls.

[0092] Advantageously, the particular conformation of the perforating device which the present invention relates to makes it possible to further facilitate the perforation of the perforable portion, as well as to facilitate the entrance or exit of the fluids from the containment compartment.

[0093] In fact, the perforating device of the present invention requires, for a very same wall thickness of the perforable portion, a smaller thrust for its perforation.

[0094] Advantageously, the specific shape of the containment compartment makes it possible to obtain an infused drink with a considerable fragrance, and the route which the infusor fluid is forced to take inside the capsule further contributes to improving the taste of such drink.

[0095] Advantageously, the support portion according to the present invention is suitable for acting as a guide during the movement of the perforating device. This way, the conversion between the configurations shown takes place in a reliable and highly repeatable manner.

[0096] Advantageously, the support portion according to the present invention is suitable for acting furthermore as a protection element of the perforating device, preventing the latter from being inadvertently converted towards the infusion configuration.

[0097] Advantageously, the capsule which the present invention relates to forms two different fluidic routes from and to the containment compartment, so that the incoming route of the infusor fluid is separated from the exit route of the infused drink.

[0098] Such different fluidic routes are advantageously reciprocally positioned so as to maximise the absorption of the aromatic essence by the infusor fluid.

[0099] Advantageously, the connection between the perforating device and the support portion is designed in such a way that the tearing occurs in a localised area

and takes place without an excessive force, given the presence of a specially weakened section.

[0100] A person skilled in the art may make variations to the aforesaid embodiments of the capsule and of the assembly or replace elements with other functionally equivalent so as to satisfy specific requirements.

[0101] For example the present invention has been illustrated above based on there being a fixed capsule inside the infusion group, such capsule having a mobile perforating device.

[0102] However, it is possible to conjecture keeping the perforating device fixed, for example in abutment with a fixed component of the infusion group, and moving the side or end wall of the capsule in relation to the perforating device by means of the mobile component of the infusion group, in such a way as to convert the capsule from the initial configuration to the infusion configuration.

[0103] In other words, the invention as shown above is equally suitable for functioning following a kinematic inversion.

[0104] Furthermore, in the above description reference is made to an infusor fluid comprising water, steam or their mixtures. It is however believed that the teaching of the present invention is equally usable in the case of liquids or vapours of other types, such as milk, and in the case of not necessarily heated liquids.

[0105] Such variations also fall within the sphere of protection as defined by the following claims.

Claims

1. Capsule (1), pod or the like, suitable for cooperating with the infusion group (2, 4) of a machine for the production of an infused drink; said capsule (1) comprising:

- a side wall (6) and at least one end wall (8', 8"), reciprocally connected so as to delimit a containment compartment (12) of at least one aromatic essence, such as coffee;

wherein at least one of said walls (6, 8', 8") comprises at least one perforable portion (10) to make a fluidic connection between the containment compartment (12) and the infusion group (2, 4) so as to obtain the infused drink;

- at least one perforating device operatively connected to the perforable portion (10) and suitable for cooperating with the infusion group (2, 4) to create the fluidic connection;

- a support portion (20) for the perforating device, connected to the side wall (6) or to the end wall (8', 8") and which extends from at least one of them (6, 8', 8"), **characterised in that** the perforating device is at least partially connected to the support portion (20) by means of a tearing portion (24) which, when torn, allows the infusor fluid to enter the containment compartment.

2. Capsule according to claim 1, wherein the perforating device is movable by the infusion group (2, 4) so that a portion of the former traverses the perforable portion (10).
3. Capsule according to claim 1 or 2, wherein the perforating device is movable in relation to the side (6) or end wall (8', 8") between an initial configuration wherein the perforable portion (10) is substantially intact, and an infusion configuration wherein said device traverses at least partially the thickness of the perforable portion (10).
4. Capsule according to any of the previous claims, wherein the side wall (6) extends around a longitudinal axis (X), and wherein the perforating device is axially movable in relation to the side wall (6).
5. Capsule according to claim 4, wherein the longitudinal extension of the perforating device is greater than that of the side wall (6).
6. Capsule according to any of the previous claims, wherein the perforating device comprises an abutment surface (16) with a component of the infusion group (2, 4), and a perforation portion (18), opposite the abutment surface (16), suitable for traversing the perforable portion (10).
7. Capsule according to claim 6, wherein the perforating device extends along a longitudinal axis (X) and wherein the perforation portion (18) comprises a bevel-cut end.
8. Capsule according to claim 7, wherein the cut end presents a plurality of sections, each corresponding to a different cutting plane, and wherein the section furthest from the tip of the perforation portion (18) has a cutting plane with a slope, or with an average slope, in relation to the longitudinal axis (X) greater than that/those of the other cutting planes which define the other sections.
9. Capsule according to any of the claims from 6 to 8, wherein the perforating device comprises a hollow pin in fluidic communication with the containment compartment (12) at least at the perforation portion (18).
10. Capsule according to any of the previous claims, wherein the support portion (20) delimits an annular cavity (22) with the perforating device, suitable for receiving the infused fluid.
11. Capsule according to any of the previous claims, wherein the perforating device is connected to an end (20') of the support portion (20).
12. Capsule according to any of the previous claims, wherein the tearing portion (24) comprises a sealing ring (26) which extends between the perforating device and the support portion (20).
13. Capsule according to any of the previous claims when dependent on claim 3, wherein the tearing portion (24) is broken at least partially simultaneously to the conversion from the initial configuration to the infusion configuration.
14. Capsule according to claim 12, further comprising flow diverting means, suitable for increasing the residence time of an infusor fluid in the containment compartment (12), wherein said diverting means comprise the sealing ring (26).
15. Assembly (28) comprising:
- an infusion group (2, 4) of a machine for the production of an infused drink; and
 - a capsule (1) according to any of the previous claims engaged in the infusion group (2, 4).
16. Assembly according to claim 15, wherein the infusion group (2, 4) comprises an infusor pin (2) suitable for abutting against the end wall (8', 8") of the capsule (1).

Patentansprüche

1. Kapsel (1), Pad oder Ähnliches, welche für das Zusammenwirken mit der Aufbrühbaugruppe (2, 4) einer Maschine zur Herstellung eines Aufbrühgetränks geeignet sind;
wobei die Kapsel (1) umfasst:
- eine Seitenwand (6) und wenigstens eine Endwand (8', 8"), die wechselseitig miteinander verbunden sind, um eine Aufnahmekammer (12) für wenigstens eine aromatische Essenz, wie beispielsweise Kaffee, zu begrenzen;
wobei wenigstens eine der Wände (6, 8', 8") wenigstens einen perforierbaren Abschnitt (10) umfasst, um eine Fluidverbindung zwischen der Aufnahmekammer (12) und der Aufbrühbaugruppe (2, 4) zu erzeugen, um das Aufgussgetränk zu erhalten;
 - wenigstens eine Perforiervorrichtung, die operativ mit dem perforierbaren Abschnitt (10) verbunden und dazu geeignet ist, mit der Aufbrühbaugruppe (2, 4) zum Schaffen einer Fluidverbindung zusammenzuwirken;
 - einen Halteabschnitt (20) für die Perforiervorrichtung, der mit der Seitenwand (6) oder der Endwand (8', 8") verbunden ist und sich von wenigstens einer aus diesen (6, 8', 8") erstreckt,

- dadurch gekennzeichnet, dass** die Perforier-
vorrichtung wenigstens teilweise mit dem Halte-
abschnitt (20) mittels eines Abreißabschnitts
(24) verbunden ist, der der Aufbrühflüssigkeit
nach Abreißen erlaubt, in die Aufnahmekammer
zu gelangen.
2. Kapsel nach Anspruch 1, wobei die Perforier-
vorrichtung durch die Aufbrühbaugruppe (2, 4) beweglich
ist, so dass ein Teil der ersten den perforierbaren
Abschnitt (10) durchquert.
 3. Kapsel nach Anspruch 1 oder 2, wobei die Perforier-
vorrichtung bezüglich der Seitenwand (6) oder End-
wand (8', 8'') beweglich ist zwischen einer Anfangs-
konfiguration, in der der perforierbare Abschnitt (10)
im Wesentlichen intakt ist, und einer Aufbrühkonfi-
guration, in der die Vorrichtung wenigstens teilweise
die Dicke des perforierbaren Abschnitts (10) durch-
quert.
 4. Kapsel nach einem der vorangehenden Ansprüche,
wobei sich die Seitenwand (6) um eine Längsachse
(X) erstreckt und wobei die Abreißvorrichtung be-
züglich der Seitenwand (6) axial beweglich ist.
 5. Kapsel nach Anspruch 4, wobei die Längsabmes-
sung der Abreißvorrichtung größer ist als diejenige
der Seitenwand (6).
 6. Kapsel nach einem der vorangehenden Ansprüche,
wobei die Abreißvorrichtung eine Anlagefläche (16)
mit einer Komponente der Aufbrühbaugruppe (2, 4)
und einen Perforationsabschnitt (18) gegenüber der
Anlagefläche (16) umfasst, der dazu geeignet ist,
den perforierbaren Abschnitt (10) zu durchqueren.
 7. Kapsel nach Anspruch 6, wobei sich die Perforier-
vorrichtung entlang einer Längsachse (X) erstreckt
und wobei der Perforationsabschnitt (18) ein Ende
mit Gehrungsschnitt umfasst.
 8. Kapsel nach Anspruch 7, wobei das geschnittene
Ende eine Mehrzahl von Abschnitten umfasst, die
jeweils einer unterschiedlichen Schnittebene ent-
sprechen, und wobei der am weitesten von der Spit-
ze des Perforationsabschnitts (18) entfernte Ab-
schnitt eine Schnittebene mit einer Neigung oder
durchschnittlichen Neigung bezüglich der Längs-
achse (X) aufweist, die größer ist als jene der ande-
ren Schnittebenen, die die anderen Abschnitte defi-
nieren.
 9. Kapsel nach einem der Ansprüche 6 bis 8, wobei die
Perforiervorrichtung wenigstens am Perforationsab-
schnitt (18) einen Hohlstift in Fluidverbindung mit der
Aufnahmekammer (12) umfasst.
 10. Kapsel nach einem der vorangehenden Ansprüche,
wobei der Halteabschnitt (20) mit der Perforier-
vorrichtung einen ringförmigen Hohlraum (22) begrenzt,
der dazu geeignet ist, die aufgebürhte Flüssigkeit
aufzunehmen.
 11. Kapsel nach einem der vorangehenden Ansprüche,
wobei die Perforiervorrichtung mit einem Ende (20')
des Halteabschnitts (20) verbunden ist.
 12. Kapsel nach einem der vorangehenden Ansprüche,
wobei der Abreißabschnitt (24) einen Abdichtungs-
ring (26) umfasst, welcher sich zwischen der Perfo-
riervorrichtung und dem Halteabschnitt (20) er-
streckt.
 13. Kapsel nach einem der vorangehenden Ansprüche,
wenn abhängig von Anspruch 3, wobei der
Abreißabschnitt (24) zumindest teilweise gleichzei-
tig mit dem Übergang von der Anfangskonfiguration
zur Aufbrühkonfiguration gebrochen wird.
 14. Kapsel nach Anspruch 12, welche ferner Durchflus-
sumlenkmittel umfasst, die dazu geeignet sind, die
Aufenthaltszeit der Aufbrühflüssigkeit in der Aufnah-
mekammer (12) zu verlängern, wobei die Umlenk-
mittel den Dichtungsring (26) umfassen.
 15. Baugruppe (28), umfassend:
 - eine Aufbrühbaugruppe (2, 4) einer Maschine
zur Herstellung eines Aufbrühgetränks; und
 - eine Kapsel (1) nach einem der vorangehen-
den Ansprüche, die in der Aufbrühbaugruppe (2,
4) eingesetzt ist.
 16. Baugruppe nach Anspruch 15, wobei die Aufbrüh-
baugruppe (2, 4) einen Infusorstift (2) umfasst, der
dazu geeignet ist, an der Endwand (8', 8'') der Kapsel
(1) in Anlage zu kommen.

Revendications

1. Capsule (1), dosette ou similaire, appropriée pour
coopérer avec le groupe d'infusion (2, 4) d'une ma-
chine pour la production d'une boisson infusée ;
ladite capsule (1) comprenant :
 - une paroi latérale (6) et au moins une paroi d'ex-
trémité (8', 8''), réciproquement raccordées afin
de délimiter un compartiment de confinement
(12) d'au moins une essence aromatique, telle
que du café ;
 - dans laquelle au moins l'une desdites parois (6,
8', 8'') comprend au moins une partie perforable
(10) pour réaliser un raccordement fluide entre
le compartiment de confinement (12) et le

- groupe d'infusion (2, 4) afin d'obtenir la boisson infusée ;
 au moins un dispositif de perforation raccordé de manière opérationnelle à la partie perforable (10) et approprié pour coopérer avec le groupe d'infusion (2, 4) afin de créer le raccordement fluide ;
 une partie de support (20) pour le dispositif de perforation, raccordée à la paroi latérale (6) ou à la paroi d'extrémité (8', 8'') et qui s'étend à partir de l'une d'entre elles (6, 8', 8''), **caractérisée en ce que** le dispositif de perforation est au moins partiellement raccordé à la partie de support (20) au moyen d'une partie de déchirement (24) qui, lorsqu'elle est déchirée permet au fluide d'infusion d'entrer dans le compartiment de confinement.
2. Capsule selon la revendication 1, dans laquelle le dispositif de perforation est mobile grâce au groupe d'infusion (2, 4) de sorte qu'une partie du premier traverse la partie perforable (10).
 3. Capsule selon la revendication 1 ou 2, dans laquelle le dispositif de perforation est mobile par rapport au côté (6) ou à la paroi d'extrémité (8', 8'') entre une configuration initiale dans laquelle la partie perforable (10) est sensiblement intacte, et une configuration d'infusion dans laquelle ledit dispositif traverse au moins partiellement l'épaisseur de la partie perforable (10).
 4. Capsule selon l'une quelconque des revendications précédentes, dans laquelle la paroi latérale (6) s'étend autour d'un axe longitudinal (X), et dans laquelle le dispositif de perforation est axialement mobile par rapport à la paroi latérale (6).
 5. Capsule selon la revendication 4, dans laquelle l'extension longitudinale du dispositif de perforation est supérieure à celle de la paroi latérale (6).
 6. Capsule selon l'une quelconque des revendications précédentes, dans laquelle le dispositif de perforation comprend une surface de butée (16) avec un composant du groupe d'infusion (2, 4), et une partie de perforation (18), opposée à la surface de butée (16) appropriée pour traverser la partie perforable (10).
 7. Capsule selon la revendication 6, dans laquelle le dispositif de perforation s'étend le long d'un axe longitudinal (X) et dans laquelle la partie de perforation (18) comprend une extrémité coupée en biseau.
 8. Capsule selon la revendication 7, dans laquelle l'extrémité coupée présente une pluralité de sections, chacune correspondant à un plan de coupe différent, et dans laquelle la section la plus éloignée de la pointe de la partie de perforation (18) a un plan de coupe avec une inclinaison, ou avec une inclinaison moyenne, par rapport à l'axe longitudinal (X), supérieure à celle/celles des autres plans de coupe qui définissent les autres sections.
 9. Capsule selon l'une quelconque des revendications 6 à 8, dans laquelle le dispositif de perforation comprend une aiguille creuse en communication fluide avec le compartiment de confinement (12) au moins au niveau de la partie de perforation (18).
 10. Capsule selon l'une quelconque des revendications précédentes, dans laquelle la partie de support (20) délimite une cavité annulaire (22) avec le dispositif de perforation, appropriée pour recevoir le fluide infusé.
 11. Capsule selon l'une quelconque des revendications précédentes, dans laquelle le dispositif de perforation est raccordé à une extrémité (20') de la partie de support (20).
 12. Capsule selon l'une quelconque des revendications précédentes, dans laquelle la partie de déchirement (24) comprend une bague d'étanchéité (26) qui s'étend entre le dispositif de perforation et la partie de support (20).
 13. Capsule selon l'une quelconque des revendications précédentes lorsqu'elle dépend de la revendication 3, dans laquelle la partie de déchirement (24) est cassée au moins partiellement simultanément lors du passage de la configuration initiale à la configuration d'infusion.
 14. Capsule selon la revendication 12, comprenant en outre des moyens d'inversion d'écoulement, appropriés pour augmenter le temps de séjour d'un fluide d'infusion dans le compartiment de confinement (12), dans laquelle lesdits moyens d'inversion comprennent la bague d'étanchéité (26).
 15. Ensemble (28) comprenant :
 un groupe d'infusion (2, 4) d'une machine pour la production d'une boisson infusée ; et
 une capsule (1) selon l'une quelconque des revendications précédentes, mise en prise dans le groupe d'infusion (2, 4) .
 16. Ensemble selon la revendication 15, dans lequel le groupe d'infusion (2, 4) comprend une aiguille d'infusion (2) appropriée pour venir en butée contre la paroi d'extrémité (8', 8'') de la capsule (1).

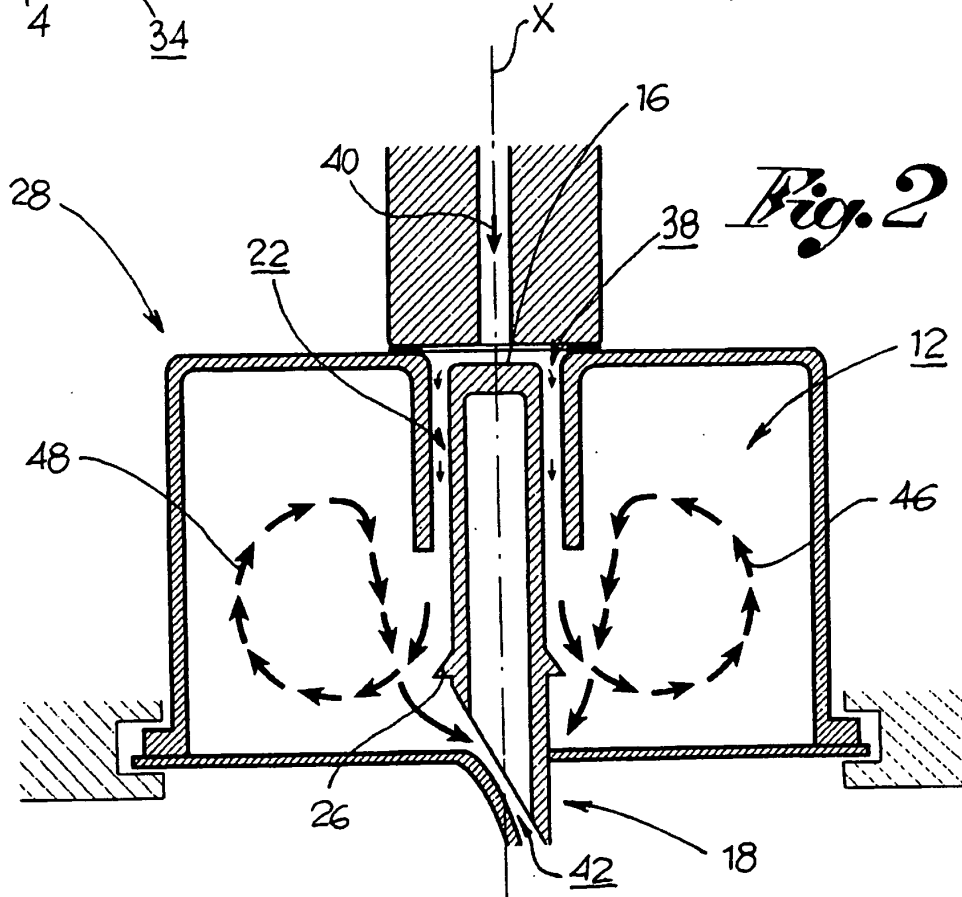
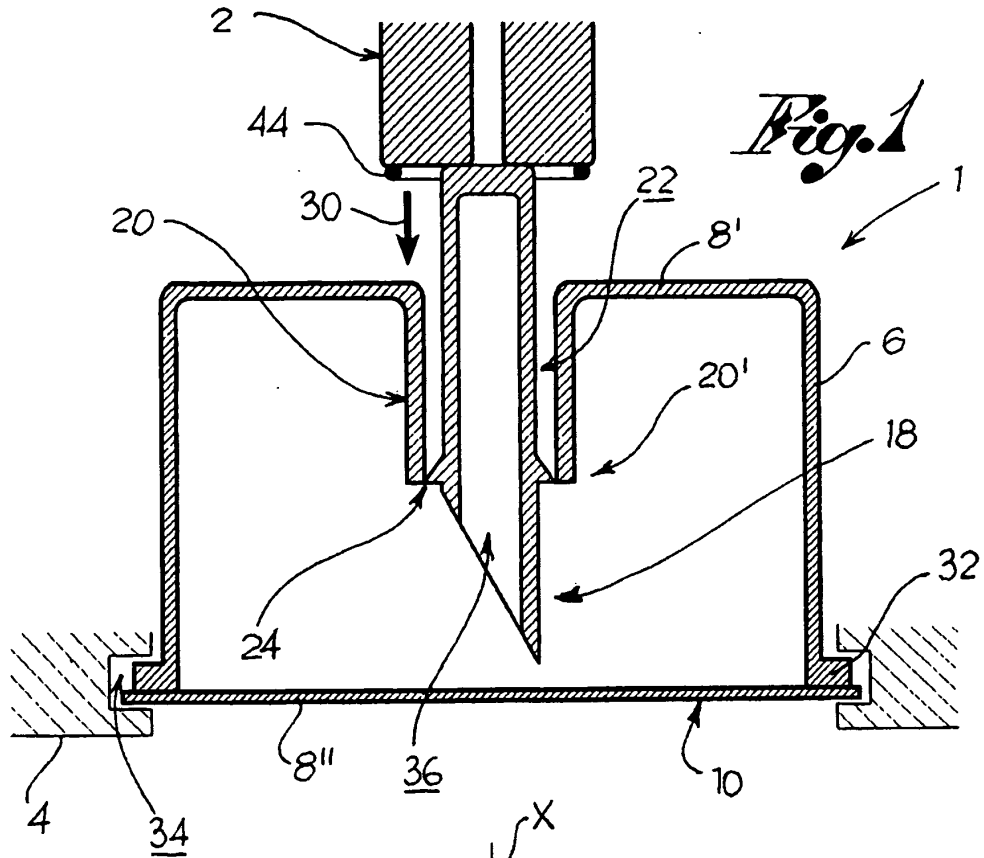

REFERENCES CITED IN THE DESCRIPTION

This list of references cited by the applicant is for the reader's convenience only. It does not form part of the European patent document. Even though great care has been taken in compiling the references, errors or omissions cannot be excluded and the EPO disclaims all liability in this regard.

Patent documents cited in the description

- GB 1256247 A [0008]
- WO 2007114685 A1 [0008]