

(19)



(11)

**EP 2 408 675 B1**

(12)

**EUROPEAN PATENT SPECIFICATION**

(45) Date of publication and mention of the grant of the patent:  
**12.07.2017 Bulletin 2017/28**

(51) Int Cl.:  
**B65D 5/74 (2006.01) B31B 50/84 (2017.01)**

(21) Application number: **10712748.2**

(86) International application number:  
**PCT/GB2010/000491**

(22) Date of filing: **17.03.2010**

(87) International publication number:  
**WO 2010/106327 (23.09.2010 Gazette 2010/38)**

(54) **POUR SPOUT AND METHOD OF MOUNTING A POUR SPOUT ON A SPIGOT**

AUSGIESSER UND VERFAHREN ZUR BEFESTIGUNG EINES AUSGIESSERS AN EINEM DORN  
BEC VERSEUR ET PROCÉDÉ DE MONTAGE D'UN BEC VERSEUR SUR UN ERGOT

(84) Designated Contracting States:  
**AT BE BG CH CY CZ DE DK EE ES FI FR GB GR HR HU IE IS IT LI LT LU LV MC MK MT NL NO PL PT RO SE SI SK SM TR**

(30) Priority: **17.03.2009 GB 0904495**

(43) Date of publication of application:  
**25.01.2012 Bulletin 2012/04**

(73) Proprietor: **ELOPAK SYSTEMS AG  
8152 Glattbrugg (CH)**

(72) Inventor: **ENEMARK, Frode  
DK-8600 Silkeborg (DK)**

(74) Representative: **Turner, Richard Charles  
Room 3, The Rufus Centre  
Steppingley Road  
Flitwick, Bedfordshire MK45 1AH (GB)**

(56) References cited:  
**US-A- 6 086 523 US-A1- 2003 071 042  
US-A1- 2004 245 262**

**EP 2 408 675 B1**

Note: Within nine months of the publication of the mention of the grant of the European patent in the European Patent Bulletin, any person may give notice to the European Patent Office of opposition to that patent, in accordance with the Implementing Regulations. Notice of opposition shall not be deemed to have been filed until the opposition fee has been paid. (Art. 99(1) European Patent Convention).

## Description

**[0001]** This invention relates to a method of mounting a pour spout on a spigot, and to a combination of such spigot and such pour spout. US-A-6,086,523 discloses a pour spout fitment which has an annular flange and an integral, removable membrane with a pull tab. The membrane has a peripheral line of weakness connected to an inward projection located halfway along the spout inner wall. The lower end of the spout may have a continuous internal bead for releasably frictionally engaging a fitment-applying spigot which is inserted into the spout lower end. The spout has a snap-on screw-threaded cap with a tamper-evident band. Instead of a continuous internal bead there may be employed a ring of segments extending peripherally of the spout, or a ring of vertical ribs formed extending upwards from adjacent the bottom edge of the spout.

**[0002]** GB-A-2,396,151 discloses an integrally moulded, tamper-evident, closure system for forming into a pour spout fitment and comprising a cap, a flanged neck and tamper-evident means. The structure allows the application of the cap to the neck by axially pressing the cap and the neck together, whereupon the tamper evident means prevents the cap from being removed from the neck while the tamper evident means remains intact. The closure system includes transition means between the top of the neck and the bottom of a band of the tamper-evident means, a locking wall, and corresponding screw-threads, wherein the transition means is attached to the neck by frangible engagement, and may be provided by a plurality of spaced elements separated by apertures, or may include one or more pleats or folds. With the closure system in the assembled condition, the fitment may be applied to a carton in a conventional manner. The inside of the bottom end of the neck is defined by a downwardly and radially outwardly inclined surface which facilitates the insertion of a spigot of a fitment applicator. A plurality of circumferentially spaced, radially inwardly projecting lugs facilitate the retention of the fitment on the spigot. The fitment may be bonded to either the outside or the inside of a carton panel, as desired.

**[0003]** US2004/0245262A1 discloses a flanged pour spout in which at least one projection is provided on an inside surface of the pour spout for releasably retaining the pour spout on a spigot which is used to apply the pour spout to a container wall. That disclosure acknowledges as known a version in which the projection takes the form of an annular bead or lip round a lower inner edge of the pour spout, as well as another version in which several separate, bead-like projections are provided distributed over the circumference of the spout on its inside surface and near to the lower inner edge. The disclosure explains that, if the pour spouts are of different sizes, the spigots for holding those spouts have to be changed because a given spout size can be held only on a suitably matched spigot, there being only slight play in order, on the one hand, to ensure the retention and transportation of the

pour spout on the spigot whilst, on the other hand, to facilitate easy removal of the spigot from the applied spout. The disclosure further explains that the changing of the spigots to suit differing spout sizes is relatively time-consuming and tiresome and significantly reduces productivity and that even slightly differing dimensions arising during the production of one-and-the-same type of pour spout can lead to malfunctions during assembly, as the spout then either slides too easily from the spigot or is held too tightly on the spigot. That disclosure proposes that the or each projection should have the form of a bendable web which is oblique to the inside surface of the pour spout, namely is at an angle smaller than 90° and greater than 0° thereto.

**[0004]** US2003/0071042A1 discloses a fitment including a spout flange, a spout, a frangible membrane and a gripping member. The spout projects upward from the spout flange and has upper and lower cylindrical portions of which the lower is of a throughflow cross-sectional area greater than that of the upper, so that an internal shoulder is formed between them. The frangible membrane seals off the spout at the upper cylindrical portion and has a peripheral edge joined to the inner peripheral surface of that upper portion along a line of weakness. The gripping member is adapted to facilitate removal of the frangible membrane from the spout. An object of that prior invention is to provide an improved gripping member in order to facilitate a user's initially opening the fitment. However, there are disclosed embodiments in which additionally the fitment has a spigot-engaging structure, in one instance at the lower end of the spout and in the form of discrete, spud-engaging protrusions which are substantially semi-circular in shape, and, in another instance, in the form of vertically extending spud-engaging splines extending radially inwardly from the inner peripheral surface of the cylindrical upper portion.

**[0005]** According to one aspect of the present invention, there is provided a method of mounting a pour spout on a spigot, comprising producing relative axial movement between the spout and the spigot to cause a leading end zone of the spigot to enter the spout and thus to cause a ridge of the spigot extending about the spigot to squeeze past a series of protrusions extending from an internal peripheral surface of the spout and distributed about said surface and to engage releasably behind said protrusions.

**[0006]** According to a second aspect of the present invention, there is provided a combination comprising a spigot including a ridge extending thereabout, and a pour spout including a series of protrusions extending from an internal peripheral surface of the spout and distributed about that surface, the ridge being of a maximum radius from a longitudinal axis of the spigot greater than the radii from that axis of the radially innermost portions of the respective protrusions, and the spigot being insertable into the pour spout sufficiently far that radially outermost portions of the ridge become located beyond said radially innermost portions.

**[0007]** In the combination, the pour spout may comprise first and second cylindrical portions of which the second portion is of a throughflow cross-sectional area greater than that of the first portion, an internal shoulder between the first and second portions, the series of protrusions extending from the internal surface of the second portion and distributed about that surface, and the radially innermost portions of the protrusions being spaced from the internal shoulder.

**[0008]** Owing to the invention, it is possible to improve the reliability of retention of the pour spout on the spigot while, nevertheless, enabling the pour spout to be readily releasable therefrom.

**[0009]** Advantageously, the protrusions are such that they yield resiliently as the ridge squeezes past them.

**[0010]** Preferably, the ridge is annular and substantially co-axial with the spigot.

**[0011]** It is advantageous if the radially innermost portions of the protrusions are substantially aligned with the internal peripheral surface of the first portion of the spout, namely that portion which is of the lesser throughflow cross-sectional area, since this facilitates injection molding of the pour spout compared with an arrangement in which those radially innermost portions project significantly inwardly beyond that internal peripheral surface of the first portion.

**[0012]** The protrusions may take the form of ribs extending longitudinally of the pour spout, those ribs may take the form of strips, and the strips may extend substantially in respective axial planes of the pour spout. Those features again facilitate injection molding.

**[0013]** In order that the invention may be clearly and completely disclosed, reference will now be made, by way of example, to the accompanying drawings, in which:-

Figure 1 is an axial sectional view through a pour spout fitment;

Figure 1A shows a detail of Figure 1 in the region encircled by chain lines;

Figure 2 is an underneath plan view of the pour spout fitment;

Figure 3 is an axial sectional view through the fitment and a plan view of a spigot approaching the fitment; and

Figure 4 corresponds to Figure 3, but shows the spigot inserted into the fitment.

**[0014]** Referring to the drawings, the pour spout fitment 2 includes a flanged pour spout 4 comprising upper and lower, substantially circular-cylindrical portions 6 and 8 of which the lower portion 8 is of a throughflow cross-sectional area greater than that of the upper portion 6. There is thus formed between the portions 6 and 8 an internal shoulder 10. A series of protrusions 12 extend

from the internal surface 14 of the portion 8 and are distributed round that surface, the radially innermost portions 16 of those protrusions 12 being spaced from the internal shoulder 10. As can be seen from Figure 1A, those radially innermost portions 16 are substantially aligned with the external peripheral surface 18 of the portion 6. The protrusions 12 take the form of profiled strips which extend in respective axial planes of the pour spout 4. The pour spout fitment 2 is completed by a screw cap 20 with a tamper-evident band 22.

**[0015]** Referring particularly to Figures 3 and 4, the spigot 24 includes an annular ridge 26 therearound and also includes a flange 28 and an internally threaded stub 30 whereby the spigot may be releasably fixed to an arm of a pour spout fitment applicator.

**[0016]** As readily understood by those of ordinary skill in the art, for mounting of the fitment 2 upon the spigot 24, once the fitment has arrived at the lower end of a supply chute and so is ready for mounting, the spigot 24 is advanced to cause the leading end zone of the spigot to enter the spout 4. This causes the ridge 26, which is of a maximum radius greater than the radii of the radially innermost portions 16 of the protrusions 12, to squeeze past the protrusions 12, the protrusions yielding resiliently, and to engage releasably behind the protrusions 12, i.e. between the protrusions 12, on the one hand, and the shoulder 10, on the other hand, as shown in Figure 4. The connection between the spout 4 and the spigot 24 is in the form of a snap connection, in which the ridge 26 fits in between the shoulder 10 and the protrusions 12 and so retains the fitment 2 firmly, but releasably, in position during its transfer to the container, where the fitment 2 is attached, particularly ultrasonically, to the container. A cylindrical part 32 of the leading end zone of the spigot 24 is received by the internal peripheral surface 18 of the portion 6. Following ultrasonic welding of the flange of the pour spout 4 to the inside surface of the relevant container panel, the spigot 24 is withdrawn from the fitment 2, the protrusions 12 again yielding resiliently, this time to enable the ridge 26 to squeeze past them in the opposite direction.

**[0017]** Because of the provision of the resilient protrusions 12, the system described with reference to the drawings is able to cope with varying play required by a range of differing types of pour spout fitments, as well as manufacturing tolerances of such fitments within a particular type, whilst the snapping of the ridge 26 behind the protrusions and fittingly between those protrusions, on the one hand, and the internal shoulder 10, on the other hand, retains the fitment more reliably and more firmly upon the spigot 24 during withdrawal from the chute and transport to the container.

## 55 Claims

1. A method of mounting a pour spout on a spigot, comprising producing relative axial movement between

- the spout (4) and the spigot (24) to cause a leading end zone (32) of the spigot (24) to enter the spout (4) and thus to cause a ridge (26) of the spigot (24) extending about the spigot (24) to squeeze past a series of protrusions (12) extending from an internal peripheral surface (14) of the spout (4) and distributed about said surface (14), and to engage releasably behind said protrusions (12).
2. A method according to claim 1, wherein said protrusions (12) yield resiliently as said ridge (26) squeezes past them.
  3. A combination comprising a spigot (24) including a ridge (26) extending thereabout, and a pour spout (4) including a series of protrusions (12) extending from an internal peripheral surface (14) of the spout (4) and distributed about that surface (14), the ridge (26) being of a maximum radius from a longitudinal axis of the spigot (24) greater than the radii from that axis of the radially innermost portions (16) of the respective protrusions (12), and the spigot (24) being insertable into the pour spout (4) sufficiently far that radially outermost portions of the ridge (26) become located beyond said radially innermost portions (16).
  4. A combination according to claim 3, wherein said ridge (26) is annular and substantially co-axial with said spigot (24).
  5. A combination according to claim 3 or 4, wherein said pour spout (4) comprises first and second cylindrical portions (6,8) of which the second portion (8) is of a throughflow cross-sectional area greater than that of the first portion (6), and an internal shoulder (10) between the first and second portions (6,8), said internal peripheral surface (14) being of said second portion (8), and the radially innermost portions (16) of said protrusions (12) being spaced from said internal shoulder (10).
  6. A combination according to claim 5, wherein said radially innermost portions are substantially aligned with an internal peripheral surface of said first portion.
  7. A combination according to any one of claims 3 to 6, wherein said protrusions are capable of yielding outwards resiliently.
  8. A combination according to any one of claims 3 to 7, wherein said protrusions take the form of ribs extending longitudinally of said pour spout.
  9. A combination according to claim 8, wherein said ribs take the form of strips.
  10. A combination according to claim 9, wherein said

strips extend substantially in respective axial planes of said pour spout.

## 5 Patentansprüche

1. Verfahren zum Anbringen eines Ausgusses an einem Zapfen, umfassend das Erzeugen einer relativen axialen Bewegung zwischen dem Ausguss (4) und dem Zapfen (24), um eine vordere Endzone (32) des Zapfens (24) in den Ausguss (4) eindringen zu lassen und damit einen über den Zapfen (24) verlaufenden Kamm (26) des Zapfens (24) sich an einer Reihe von Vorsprüngen (12), die sich von einer inneren Umfangsfläche (14) des Ausgusses (4) aus erstrecken und um die Oberfläche (14) herum verteilt sind, vorbeidrücken und lösbar hinter den Vorsprüngen (12) eingreifen zu lassen.
2. Verfahren nach Anspruch 1, wobei die Vorsprünge (12) elastisch nachgeben, wenn sich der Kamm (26) an ihnen vorbeidrückt.
3. Kombination, umfassend einen Zapfen (24) mit einem sich herum erstreckenden Kamm (26) und einen Ausguss (4) mit einer Reihe von Vorsprüngen (12), die sich von einer inneren Umfangsfläche (14) des Ausgusses (4) aus erstrecken und um diese Fläche (14) verteilt sind, wobei der Kamm (26) einen maximalen Radius von einer Längsachse des Zapfens (24) aufweist, der größer ist als die Radien von dieser Achse der radial innersten Abschnitte (16) der jeweiligen Vorsprünge (12), und wobei der Zapfen (24) in den Ausguss (4) ausreichend weit einschiebbar ist, so dass radial äußerste Abschnitte des Kamms (26) über die radial innersten Abschnitte (16) hinaus angeordnet sind.
4. Kombination nach Anspruch 3, wobei der Kamm (26) ringförmig ist und im Wesentlichen koaxial mit dem Zapfen (24) ist.
5. Kombination nach Anspruch 3 oder 4, wobei der Ausguss (4) einen ersten und einen zweiten zylindrischen Abschnitt (6, 8) aufweist, dessen zweiter Abschnitt (8) eine Durchflussquerschnittsfläche aufweist, die größer ist als die des ersten Abschnitts (6) und einer inneren Schulter (10) zwischen dem ersten und dem zweiten Abschnitt (6, 8), wobei die innere Umfangsfläche (14) der zweite Abschnitt (8) ist und die radial innersten Abschnitte (16) der Vorsprünge (12) von der inneren Schulter (10) beabstandet sind.
6. Kombination nach Anspruch 5, wobei die radial innersten Abschnitte im Wesentlichen mit einer inneren Umfangsfläche des ersten Abschnitts gefluchtet sind.

7. Kombination nach einem der Ansprüche 3 bis 6, wobei die Vorsprünge in der Lage sind, nach außen federnd nachzugeben.
8. Kombination nach einem der Ansprüche 3 bis 7, wobei die Vorsprünge die Form von Rippen aufweisen, die sich in Längsrichtung des Ausgusses erstrecken.
9. Kombination nach Anspruch 8, wobei die Rippen die Form von Streifen aufweisen.
10. Kombination nach Anspruch 9, wobei sich die Streifen im Wesentlichen in jeweiligen axialen Ebenen des Ausgusses erstrecken.

### Revendications

1. Procédé de montage d'un bec verseur sur un robinet, comprenant la production d'un mouvement axial relatif entre le bec (4) et le robinet (24) pour provoquer l'entrée d'une zone d'extrémité avant (32) du robinet (24) dans le bec (4) et pour presser ainsi une arrête (26) du robinet (24) qui s'étend autour du robinet (24) au-delà d'une série de protubérances (12) qui s'étendent depuis une surface périphérique interne (14) du bec (4) et sont distribuées autour de ladite surface (14), et pour l'engager de manière amovible derrière lesdites protubérances (12).
2. Procédé selon la revendication 1, dans lequel lesdites protubérances (12) procurent une résistance lorsque ladite arrête (26) est pressée au-delà de celles-ci.
3. Combinaison comprenant un robinet (24) incluant une arrête (26) qui s'étend autour de celui-ci et un bec verseur (4) incluant une série de protubérances (12) qui s'étendent depuis une surface périphérique interne (14) du bec (4) et qui sont distribuées autour de cette surface (14), l'arrête (26) présentant un rayon maximum depuis un axe longitudinal du robinet (24) supérieur aux rayons depuis cet axe des portions radialement les plus internes (16) des protubérances respectives (12), et le robinet (24) étant insérable dans le bec verseur (4) suffisamment loin pour que des portions radialement les plus externes de l'arrête (26) soient situées au-delà desdites portions radialement les plus internes (16).
4. Combinaison selon la revendication 3, dans laquelle ladite arrête (26) est annulaire et substantiellement coaxiale avec ledit robinet (24).
5. Combinaison selon la revendication 3 ou 4, dans laquelle ledit bec verseur (4) comprend des première et deuxième portions cylindriques (6,8) dont la deuxième portion (8) présente une section transver-

- 5 sale de passage supérieure à celle de la première portion (6), et un épaulement interne (10) entre les première et deuxième portions (6, 8), ladite surface périphérique interne (14) appartenant à ladite deuxième portion (8), et les portions radialement les plus internes (16) desdites protubérances (12) étant espacées dudit épaulement interne (10).
- 10 6. Combinaison selon la revendication 5, dans laquelle lesdites portions radialement les plus internes sont substantiellement alignées avec une surface périphérique interne de ladite première portion.
- 15 7. Combinaison selon l'une quelconque des revendications 3 à 6, dans laquelle lesdites protubérances peuvent procurer une résistance vers l'extérieur.
- 20 8. Combinaison selon l'une quelconque des revendications 3 à 7, dans laquelle lesdites protubérances prennent la forme de nervures qui s'étendent longitudinalement sur ledit bec verseur.
- 25 9. Combinaison selon la revendication 8, dans laquelle lesdites nervures prennent la forme de bandes.
- 30 10. Combinaison selon la revendication 9, dans laquelle lesdites bandes s'étendent substantiellement dans des plans axiaux respectifs dudit bec verseur.

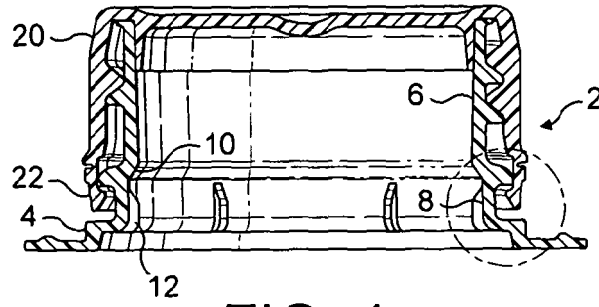

FIG. 1

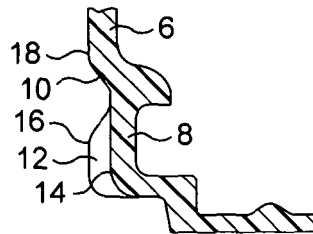

FIG. 1A

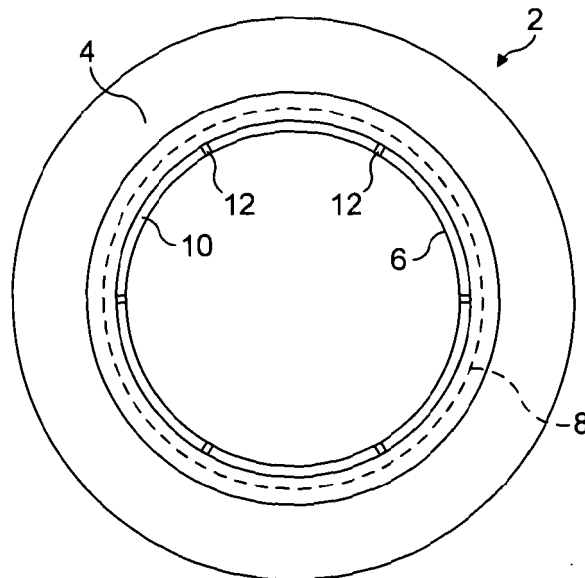

FIG. 2

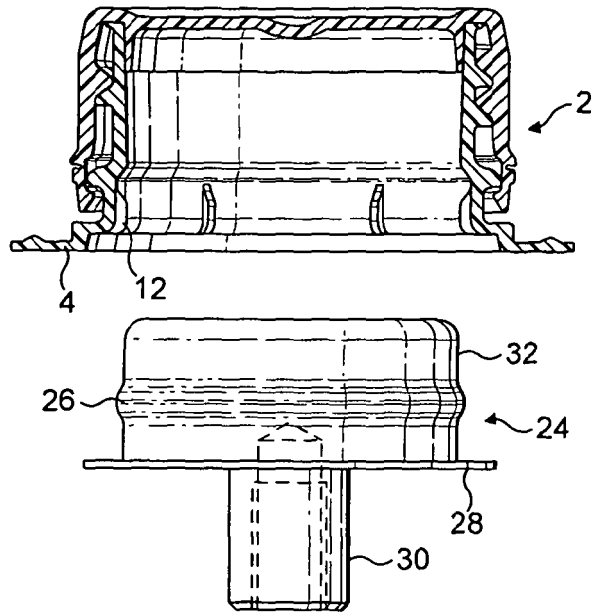

FIG. 3

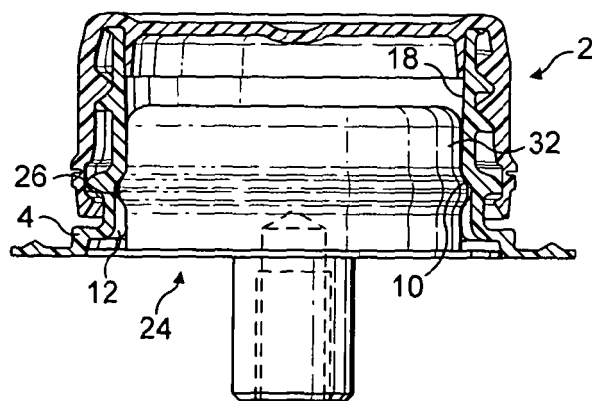

FIG. 4

**REFERENCES CITED IN THE DESCRIPTION**

*This list of references cited by the applicant is for the reader's convenience only. It does not form part of the European patent document. Even though great care has been taken in compiling the references, errors or omissions cannot be excluded and the EPO disclaims all liability in this regard.*

**Patent documents cited in the description**

- US 6086523 A [0001]
- GB 2396151 A [0002]
- US 20040245262 A1 [0003]
- US 20030071042 A1 [0004]