

(19)



(11)

EP 2 416 312 A1

(12)

EUROPEAN PATENT APPLICATION

(43) Date of publication:
08.02.2012 Bulletin 2012/06

(51) Int Cl.:
G10K 5/00 (2006.01)

(21) Application number: **10180479.7**

(22) Date of filing: **27.09.2010**

(84) Designated Contracting States:
**AL AT BE BG CH CY CZ DE DK EE ES FI FR GB
 GR HR HU IE IS IT LI LT LU LV MC MK MT NL NO
 PL PT RO SE SI SK SM TR**
 Designated Extension States:
BA ME RS

(72) Inventor: **Foxcroft, Ron**
Burlington Ontario L7P 3M2 (CA)

(74) Representative: **Grund, Martin**
Grund
Intellectual Property Group
Postfach 44 05 16
80754 München (DE)

(30) Priority: **06.08.2010 US 371227 P**

(71) Applicant: **Fox 40 International Inc.**
Stoney Creek, ON L8E 5P1 (CA)

(54) **Whistle with finger grip**

(57) A whistle (100) for producing resonant frequencies comprising a body which includes a mouth piece having an inlet (114), and at least two sound chambers (164,166) to which inlet air is blown from the inlet (114). The whistle further includes air passageways (150,152) for communicating inlet air from the inlet (114) to the sound box and sound chambers. The body further in-

cludes at least two exhaust ports (160,162) in communication with the sound chambers for discharging air and sound. The two sound chambers (164,166) are dimensioned to create peak principal frequencies which interactively produce a pulsating sound having a periodic pulse frequency of less than 100 hertz. The whistle (100) preferably includes air intake ports for communicating additional port air into the sound box.

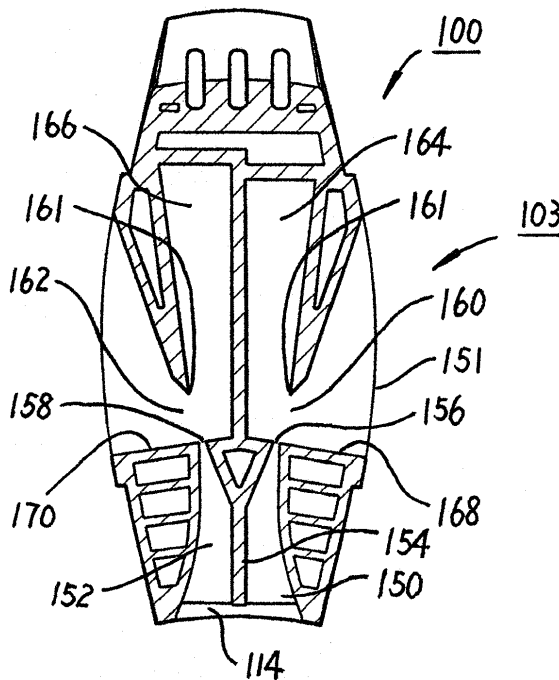

FIGURE - 10

EP 2 416 312 A1

Description

[0001] This application claims priority from US provisional Application No: 61/371,227 filed August 6, 2010 by Ron Foxcroft under the title: WHISTLE WITH FINGER GRIP.

Field of the Invention

[0002] The present invention relates to whistles and in particular relates to whistles providing a pre-selected pulsating sound and having a resiliently biased finger grip.

Background of the Invention

[0003] Whistles are used for many purposes ranging from use by referees to control sports events to emergency use to attract attention. The required characteristics of whistles depend upon the intended use. For instance a professional referee needs a whistle, which responds reliably to produce a loud noise so that the referee can control a game regardless of crowd noise. In some circumstances such as in emergency situations one wants to have a whistle which produces a very loud piercing sound which will attract the attention of nearby persons that may be able to provide assistance.

[0004] In sporting events referees have come to use certain whistles, which produce a certain sound. In many cases the whistles that are being used by referees stem from historical circumstances. The use of a particular type of whistle that produces a certain sound has often become well known to both players and audience of the games alike.

[0005] Historically most of these whistles have been pea whistles meaning whistles, which contain a rotating ball within the sound or resonating chamber. More recently however there has been a shift to the use of pea-less whistles, which are whistles which do not include the use of a rotating ball or pea within the resonating and/or sound chamber. The advantages of the pea-less whistle have been discussed in numerous prior art documents including US patent 5816816 and US patent 4821670.

[0006] Despite the advantages of the pea-less whistle designs which are currently on the market in many instances they have not been accepted in certain sporting venues due to the differences in the sounds produced by the pea-less whistle and the conventional pea styles whistles. Referees and participants in the sporting events and spectators alike have become accustomed to a certain sound which has been broadly accepted within the sporting venue and the whistle which produces that particular sound is the preferred whistle even though the technology within the whistle itself may be less than optimal.

[0007] Therefore there is a need for a whistle which can emulate as closely as possible the sound of a pea-whistle using a pea-less design by creating a whistle which is able to emulate the sound of a particular pea-

whistle without the disadvantages associated with the pea-design.

[0008] In addition referees require a whistle, which is comfortable to grip with ones fingers and reliably produce a constant sound.

[0009] US patent 6837177 discusses the possibility of producing a two-chambered whistle wherein the chambers have different resonate frequencies. In particular US patent 6837177 calls for a first chamber having a resonate frequency of 3.4 kilohertz and a second resonate chamber having a resonate frequency of 3.7 kilohertz. This produces a beat frequency of approximately 300 hertz. US patent 6837177 teaches that if the beat frequency is less than 100 hertz the beat is almost negligible with the result that the sound is monotonous. In other words US patent 6837177 is teaching a beat frequency which is at least greater than 100 hertz. US patent 4709651 also discusses the possibility of having a whistle having two sound chambers producing different resonate frequencies. In fact US patent 4709651 teaches that the resonate frequencies of the two sound producing chambers are arranged to produce relatively high and low frequency sounds. In their preferred arrangement the sound range of the whistle namely the two sound producing chambers is such as to substantially cover the upper and lower limits of human hearing. They give the example of the frequency range of the whistle between 2 kilohertz and 8 kilohertz. This patent again teaches a very wide difference in frequencies between the two sound producing chambers namely of the order of 6 kilohertz.

[0010] US patent 5816186 also discusses the concept of providing a whistle that produces beats through the arrangement of two resonate frequencies from two separate sound resonating chambers. This patent does not quantify or discuss how to select a certain beat frequency and/or the ability to emulate the sound of a pea-whistle using a pea-less design.

[0011] In summary the current art teaches the possibility of having two sound resonating chamber pea-less whistle creating a certain beat frequency which is typically 100 hertz and/or more in order to provide a particular beat.

[0012] The present whistle produces a pulse rather than a beat and the inventor has found in practice that it is the pulse sound and not a beat that is required in order to emulate the sound of the existing pea-whistle designs. It has also been found that the introduction of additional air through intake ports helps to emulate the sound of a pea style whistle in a pea less design.

Brief Description of the Drawings

[0013] The whistle will now be described by way of example only with reference to the following drawings in which;

Figure 1 is a schematic front side perspective view of the whistle.

Figure 2 is a front bottom schematic perspective view of the whistle.

Figure 3 is the right side elevational view of the whistle.

Figure 4 is a left side elevational view of the whistle.

Figure 5 is a top plan view of the whistle.

Figure 6 is a front end plan view of the whistle.

Figure 7 is a bottom plan view of the whistle.

Figure 8 is a rear end plan view of the whistle.

Figure 9 is a partial front end plan view of the whistle.

Figure 10 is a schematic cross sectional view of the whistle taken along lines AA of Figure 9.

Figure 11 is a partial schematic front elevational view of the whistle. Figure 12 is a schematic cross sectional view of the whistle taken along lines BB of Figure 11.

Figure 13 is a schematic side elevational partial cut away view of the whistle showing the hard plastic components and the rubber overlay.

Figure 14 is a side schematic elevational view of the whistle showing only the rubber overlay portion of the whistle.

Figure 15 is a schematic cross sectional side view of the whistle showing small fingers housed within the finger grip sleeve of the finger grip showing the V-spring in a normal position.

Figure 16 is a side cross sectional schematic view of large fingers shown within the finger sleeve of the finger grip with the V-spring shown in the expanded position.

Figure 17 is a top front schematic perspective view of an alternate embodiment of namely whistle 500.

Figure 18 is a schematic cross sectional view of whistle 500 taken along lines AA of Figure 19.

Figure 19 is a schematic partial front elevational view of the alternate embodiment namely whistle 500.

Figure 20 is a graph depicting sound decibels on the Y-axis and frequency on the X-axis showing two frequency charts superimposed one on the other comparing a traditional ball whistle with the present whistle design.

Figure 21 is a chart showing decibels on the Y- axis and frequency on the X- axis for a traditional ball whistle.

Figure 22 is a graph depicting amplitude on the Y-axis and time along the X- axis showing the periodic pulse frequency of a traditional ball whistle, which is graphed in Figure 21.

Figure 23 is a graph depicting decibels on the Y-axis and frequency on the X-axis showing the frequency fingerprint of the whistle made in accordance with the present design.

Figure 24 is a chart showing amplitude on the Y axis and time on the X-axis showing the periodic pulse frequency of the present design depicted in graph form in Figure 23.

Figure 25 is a schematic chart showing decibel levels on the Y-axis and frequency on the X-axis super imposing a traditional ball whistle and the present design whistle.

25 Detailed Description of the Preferred Embodiments

[0014] The present device a whistle shown generally as 100 in the Figures includes the following major components namely a body 110 having a mouthpiece 112, which defines an inlet 114. Whistle 100 further includes a finger grip 116, which is comprised of a finger sleeve 118 and also includes a V-spring 130.

[0015] Whistle 100 can be oriented relative to a horizontal plane 122 and a vertical plane 120 as shown in Figure 6.

[0016] Whistle 100 further includes a right exhaust port 160, a left exhaust port 162, a right side 136, a left side 138, a top side 140, a bottom side 142, a front portion 144 and a rear portion 146, a central portion 132 and an exterior surface 151.

[0017] Now referring specifically to Figure 10, which shows in cross section the whistle 100 along lines A-A of Figure 9 and includes the following inlet 114 which is divided into a right air passageway 150 and a left air passageway 152 with an air divider 154. Passageways 150 and 152 terminate at right air orifice 156 and left air orifice 158 respectively and direct air into sound box 103. The air blown typically using the mouth through inlet 114 exits through right air orifice 156 and left air orifice 158 into sound box 103 and impinges upon edges 161 and interacts with right sound chamber 164 and left sound chamber 166 and exits through right exhaust port 160 and left exhaust port 162 partially defined by right deflector 168 and left deflector 170.

[0018] Referring now to Figure 12 which is a cross sectional view along lines B-B of Figure 11, the hard plastic components of whistle 100 are shown in Figure 12 as body core 180.

[0019] In the moulding process the hard plastic components are generally moulded and assembled to form body core 180 and thereafter a rubber overlay as shown as 182 in Figure 14 is moulded over top of the hard plastic body core 180.

[0020] Figure 14 shows the rubber overlay 182 portion of whistle 100 whereas Figure 13 shows the hard plastic body core 180 together with the rubber overlay 182. The reader will note that finger grip 116 is mostly made of rubber overlay material 182. The interior 119 of finger sleeve 118 is completely made of elastomeric material which preferably is an elastomeric rubber overlay 182, as is V-spring 130.

[0021] Figures 15 and 16 show schematically small fingers 194 and large fingers 196 inserted into finger sleeve 118 of finger grip 116. In Figure 15 small fingers 194 are shown within finger sleeve 118 wherein V-spring 130 is in a normal position 190. Normal position 190 V-spring 130 may be slightly expanded to resiliently bias against the exterior of fingers 194 as shown in Figure 15.

[0022] In Figure 16 large fingers 196 are shown within finger sleeve 118 such that V-spring 130 is shown in the expanded position 192. In the expanded position 192, finger sleeve 118 can accommodate larger fingers as shown as large fingers 196 in Figure 16 and continue to resiliently bias against the exterior of large fingers 196.

[0023] Figures 17, 18 and 19 show an alternate embodiment namely whistle 500 which includes almost all of the same components as whistle 100 with the addition of a right intake port 502 and a left intake port 504. Right intake port 502 and left intake port 504 allow port air to enter separately from inlet air entering inlet 501. Port air is naturally drawn in rather than blown in as is the case with inlet air entering inlet 501. Port air is drawn into right intake port 502 and left intake port 504 through a venturi or siphoning action which occurs by placing the air orifices 512 and 514 in close proximity to right air aperture 510 and left air aperture 511. Right air aperture 510 and left air aperture 511 exit at right deflector 506 and left deflector 508 proximate right air orifice 512 and left air orifice 514 which communicate with right sound chamber 520 and left sound chamber 522.

[0024] Inlet 501 is divided into a right air passageway 550 and a left air passageway 552 and discharges inlet air into the sound box 503. The passageways 550 and 552 exhaust inlet air into the sound box 503 at air orifices 512 and 514. In practice it has been found that the use of the right intake port 502 and left intake port 504 creates a sound emanating from whistle 500 which more closely emulates the sound of the traditional pea-style whistle. In practice it is preferable to orient the air apertures 510 and 511 between the orifices and the exterior surface 551. In other words the air apertures 510 and 511 are closer to the exterior surface than the air orifices. The sound box includes deflectors 506 and 508 for deflecting sound forwardly, and the air orifices 512 and 514, and air apertures 510 and 511 are preferably located along the deflector.

[0025] Referring now to Figures 20 through to 25, which generally are charts, which show on the Y-axis decibel sound levels and on the X-axis frequency and/or time. Figure 20 shows the sound profile of a traditional ball whistle 300 and the present whistle 100.

[0026] The present whistle 100 appears in Figure 20 as having a single peak however in practice with a finer resolution of the measuring equipment in fact the peak which occurs at approximately 2250 hertz is actually a twin peak one having a peak at 2216 hertz and the other having a peak at 2287 hertz as depicted in Figure 25.

[0027] These frequency peaks namely the 2216 hertz peak shown as 320 and the 2287 hertz peak shown as 322 create a periodic pulse frequency of 71 hertz. The peak principal frequency of 2216 hertz corresponds to one of the sound chambers and the peak principal frequency of 2287 hertz corresponds to the other sound chamber in whistle 100. The peak principal frequency difference causes interference of these two frequencies resonating from the two sound chambers which creates the periodic pulse frequency which preferably is in the range of 10 to 100 hertz in order to provide a pulsating sound emulating the traditional pea-type whistle.

[0028] Referring to Figure 21 which depicts decibels in the Y-axis and frequency on the X-axis of a traditional ball whistle 300 and Figure 22 which shows the corresponding periodic pulse period WB as shown as 350 in Figure 22. WB shown as 350 the pulse period in Figure 22 is measured at 50 hertz ($wb = 50$ hertz) which are the measurements taken from a traditional pea-style whistle.

[0029] Figure 23 depicts decibels on the Y-axis and frequency on the X-axis and shows a peak frequency of approximately 2216 hertz. However as described above in Figure 25 the peak is actually a twin peak having two peak frequencies of 2216 hertz and 2287 hertz. The pulse period W for the present whistle 100 is shown in Figure 24 and is measured at 71 hertz ($W = 71$ hertz) which is the periodic pulse frequency due to the interactions of the principle frequencies of the two sound chambers.

[0030] The reader will note that in Figures 20 there are other smaller peaks to the right of the peak principle frequency which are called harmonic peak frequencies and/or simply harmonic frequencies which add very little to the sound being heard from the whistle.

Claims

1. A whistle for producing resonant frequencies comprising:
 - a) a body including a mouth piece having an inlet, at least two sound chambers to which inlet air is blown from the inlet;
 - b) air passageways for communicating inlet air from the inlet to the sound box and sound chambers;
 - c) the body further including at least two exhaust

- ports in communication with the sound chambers for discharging air and sound;
- d) **characterized in that** the two sound chambers are dimensioned to create peak principal frequencies which interactively produce a pulsating sound having a periodic pulse frequency of less than 100 hertz. 5
2. The whistle claimed in claim 1 **characterized in that** the body further including air intake ports for communicating additional port air into the sound box. 10
3. The whistle claimed in claim 2 **characterized in that** the air intake ports drawing in port air independently of inlet air. 15
4. The whistle claimed in claim 1 **characterized in that** the body further including air intake ports for communicating additional port air into the sound box wherein the port air is drawn into the intake ports by siphoning action from the adjacent flow of inlet air. 20
5. The whistle claimed in claim 6 **characterized in that** the sound box including deflectors for deflecting sound forwardly, and the air orifices, and air apertures located along the deflector. 25
6. The whistle claimed in claim 8 **characterized in that** the air apertures located adjacent and in close proximity to the air orifices along the deflector. 30
7. The whistle claimed in claim 1 **characterized in that** the two sound chambers are dimensioned to create peak principal frequencies which interactively produce a pulsating sound having a periodic pulse frequency of between 10 to 100 hertz. 35
8. The whistle claimed in claim 1 **characterized in that** a finger grip integrally connected to the body for receiving at least one finger therein including a resiliently biased expandable portion for gripping the fingers. 40
9. The whistle claimed in claim 9 **characterized in that** the finger grip including a contiguous finger sleeve. 45
10. The whistle claimed in claim 10 **characterized in that** the contiguous finger sleeve includes a V shaped expansion spring moveable between a normal position and an expanded position for accommodating variations in finger size. 50

55

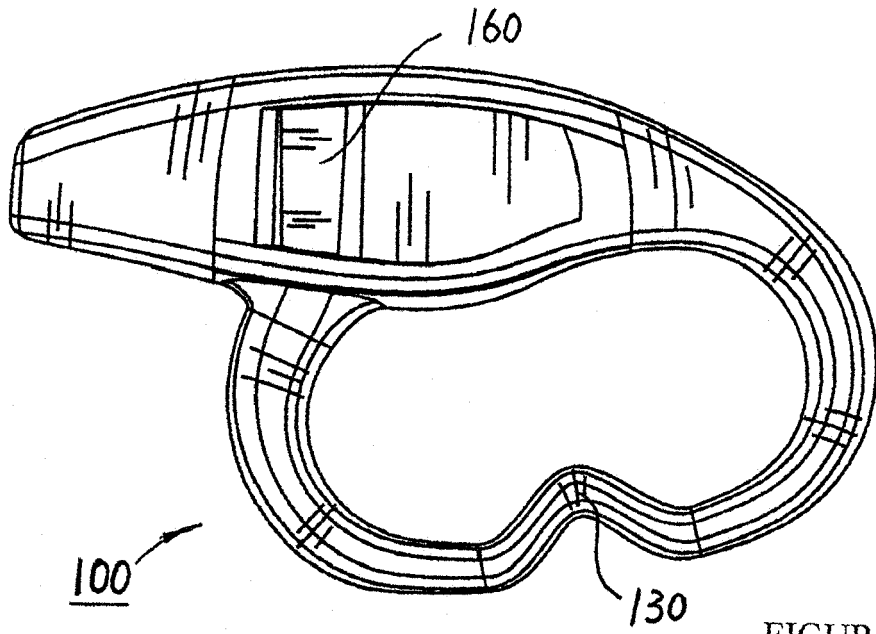

FIGURE - 3

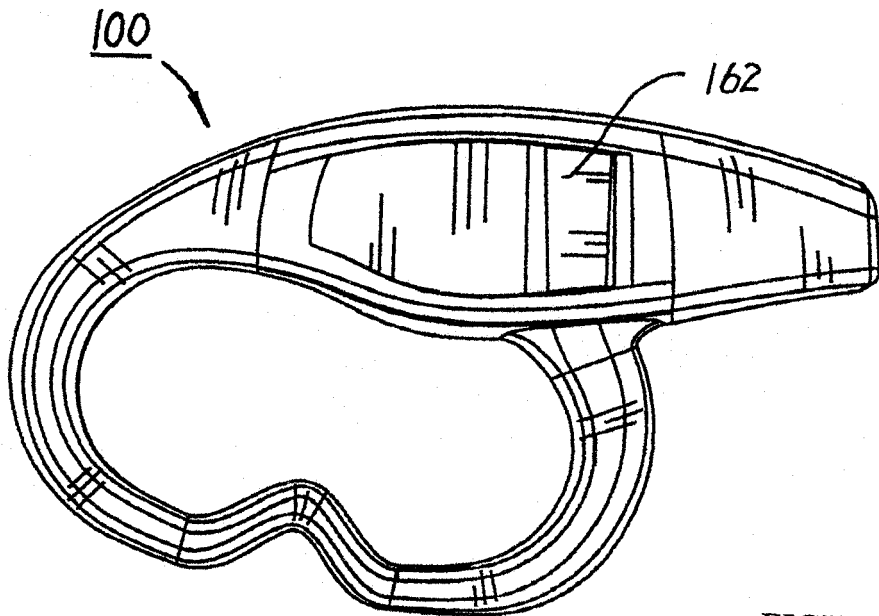

FIGURE - 4

FIGURE - 5

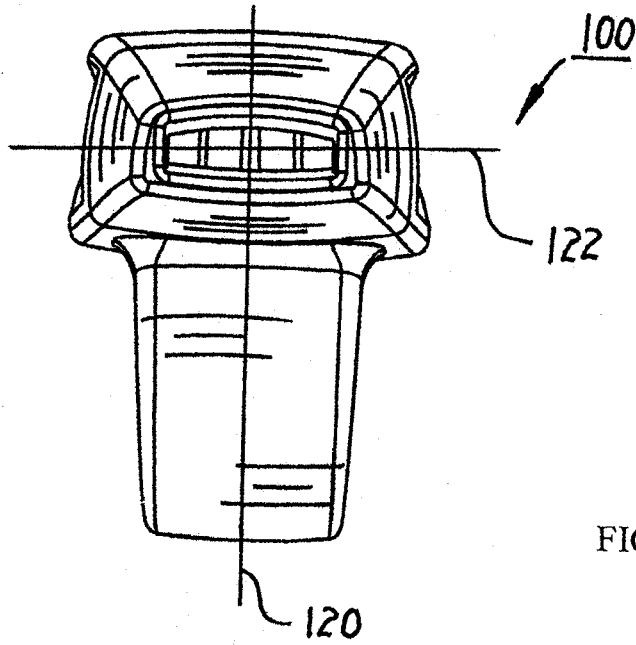
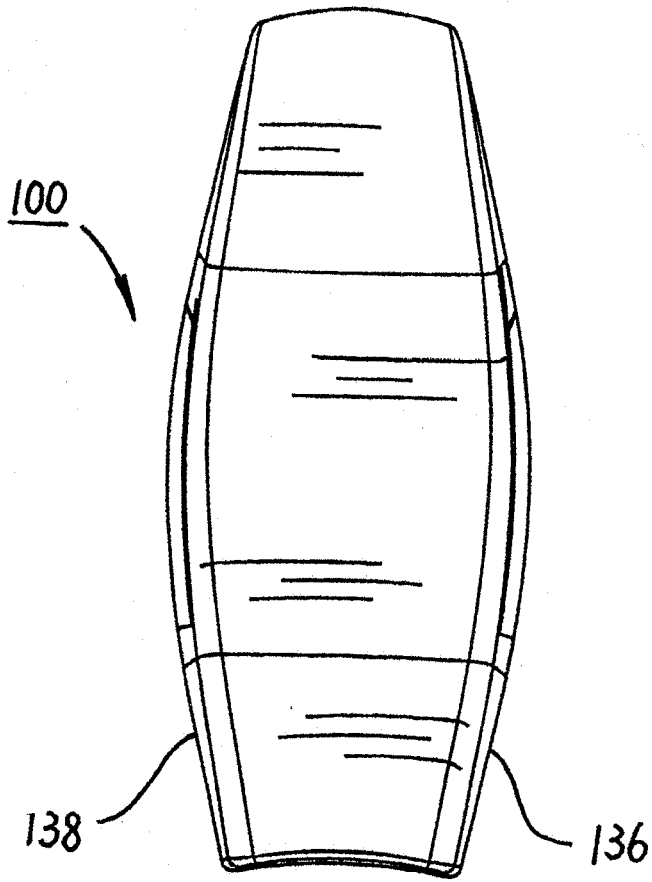

FIGURE - 6

FIGURE - 7

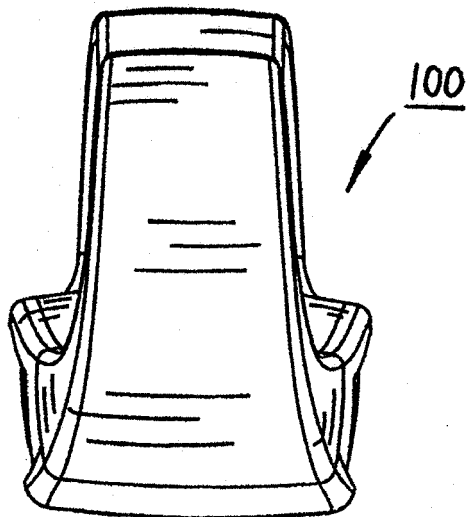
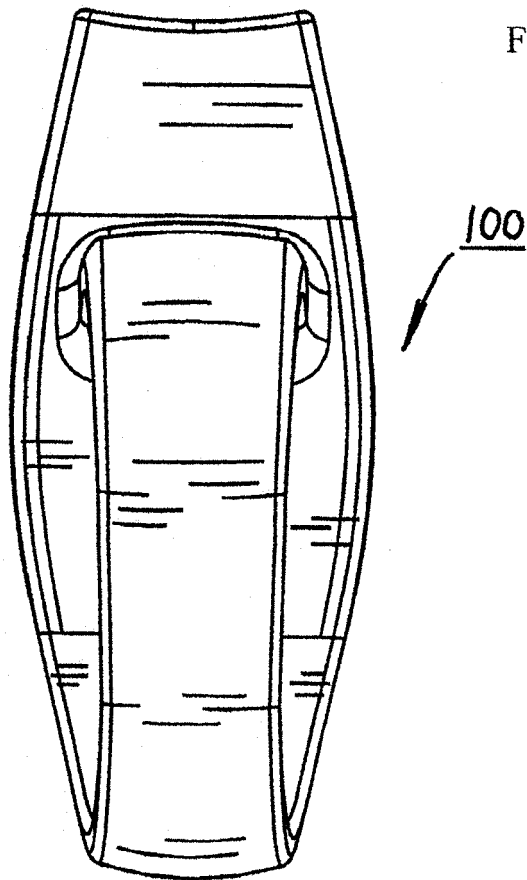

FIGURE - 8

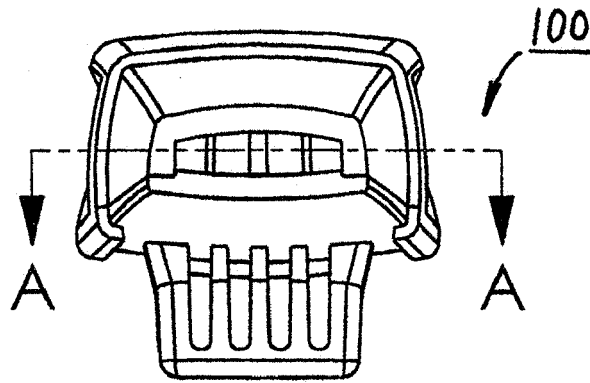

FIGURE - 9

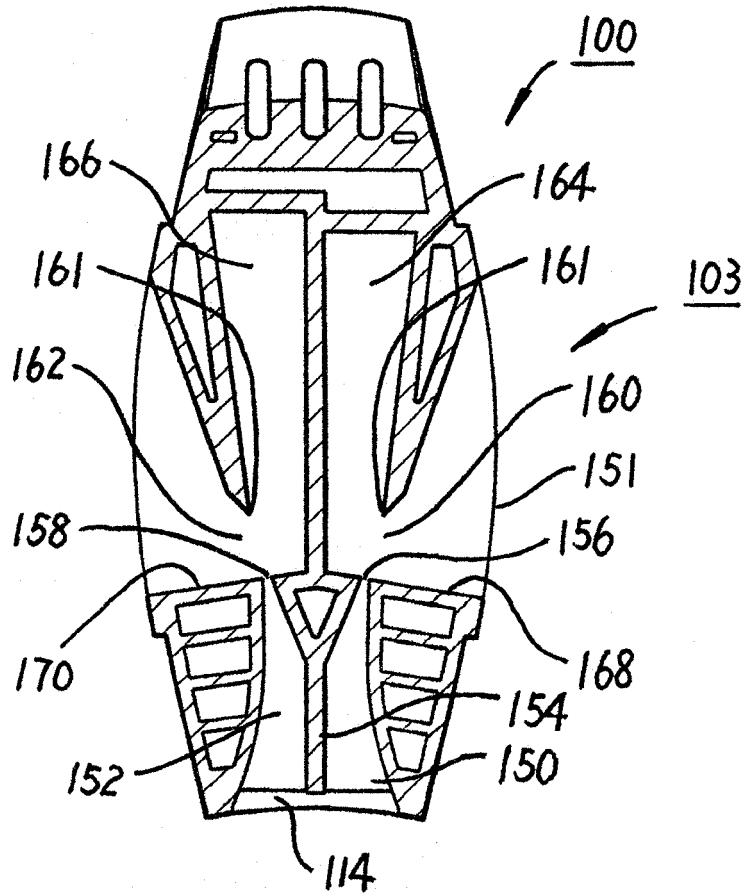

FIGURE - 10

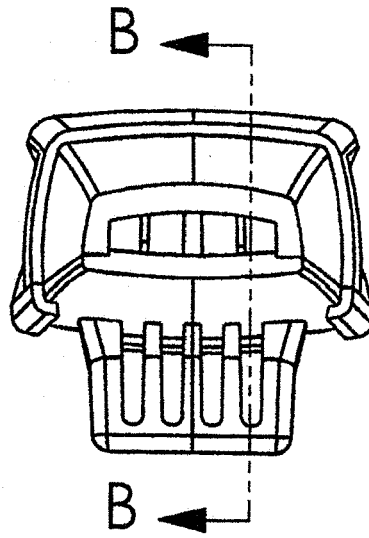

FIGURE - 11

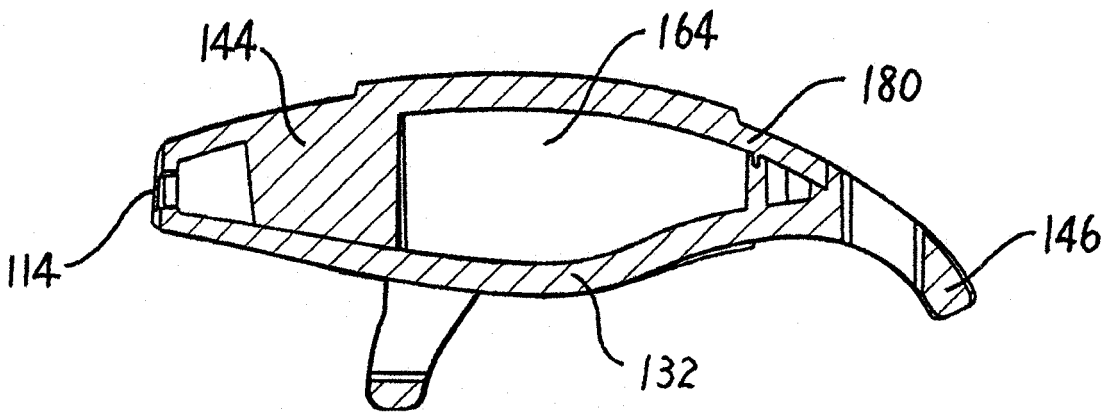
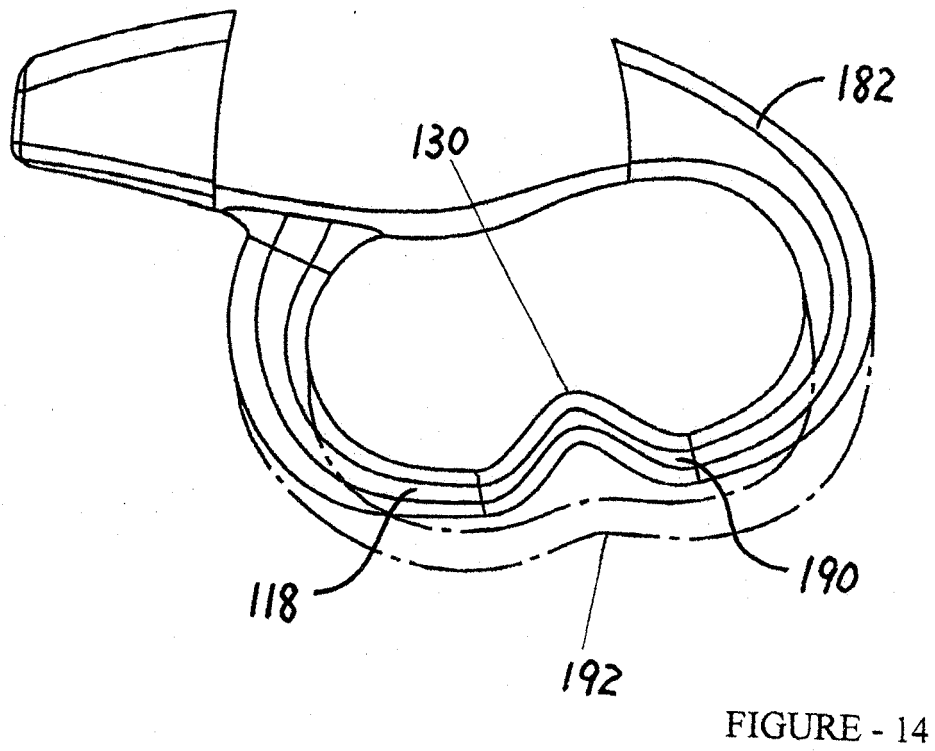
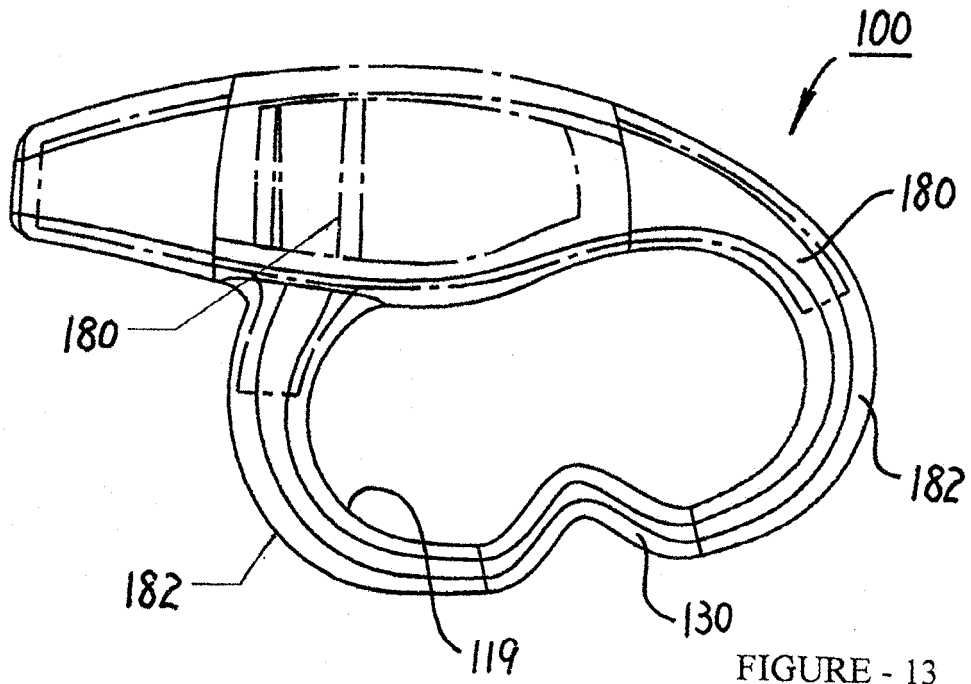

FIGURE - 12



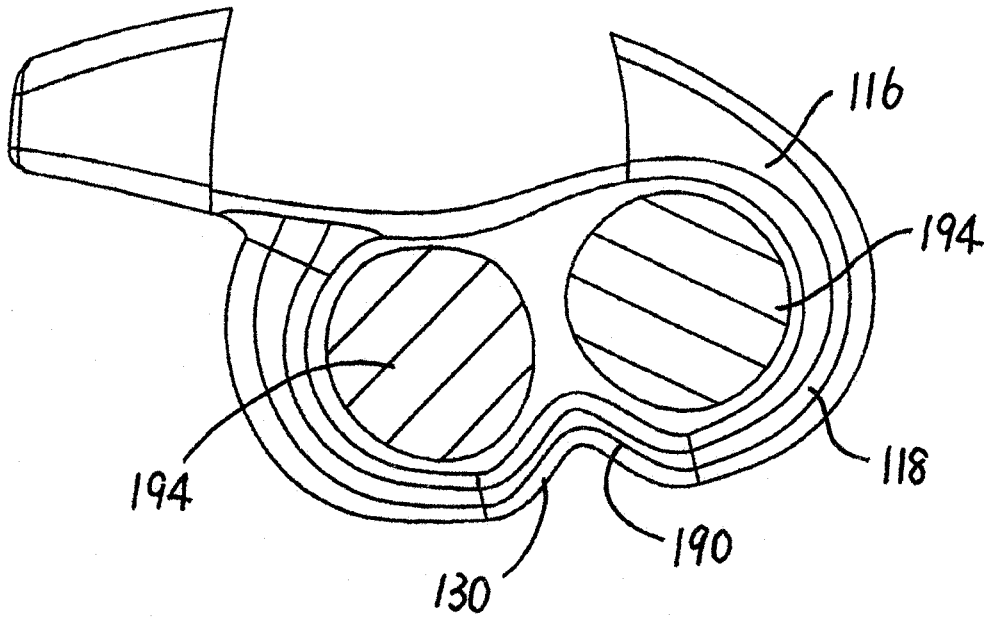

FIGURE - 15

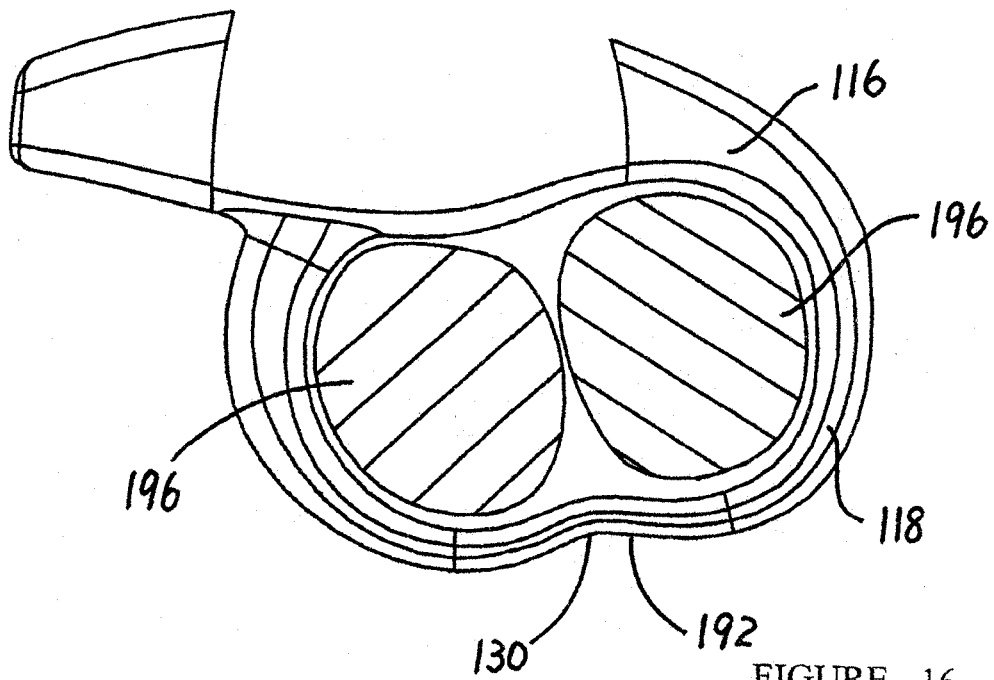

FIGURE - 16

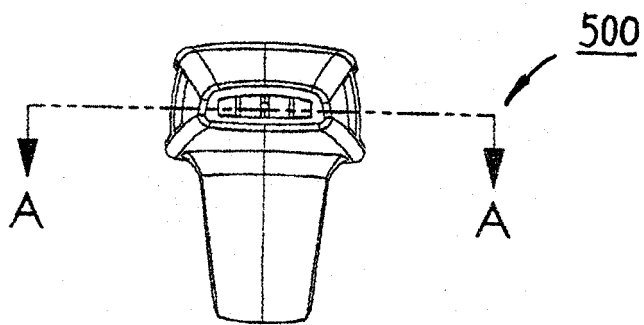
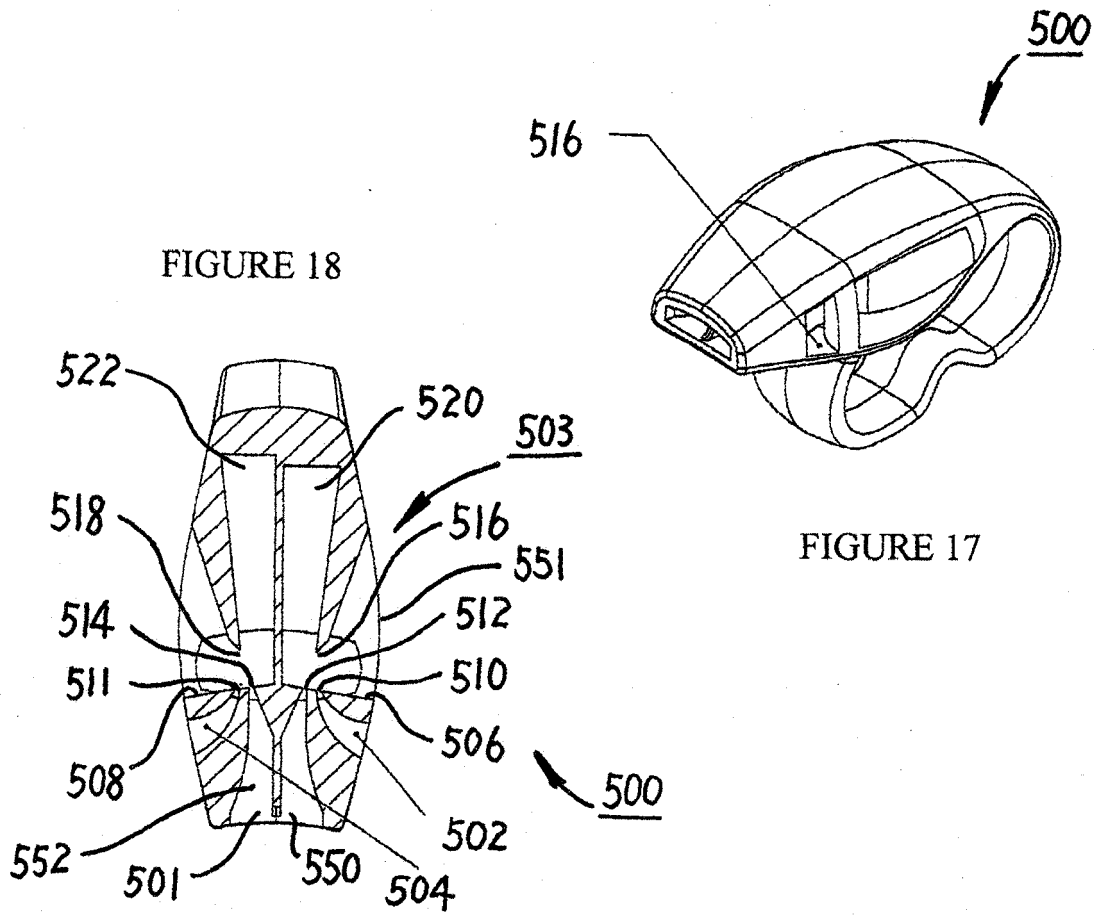

FIGURE 19

FIGURE 20

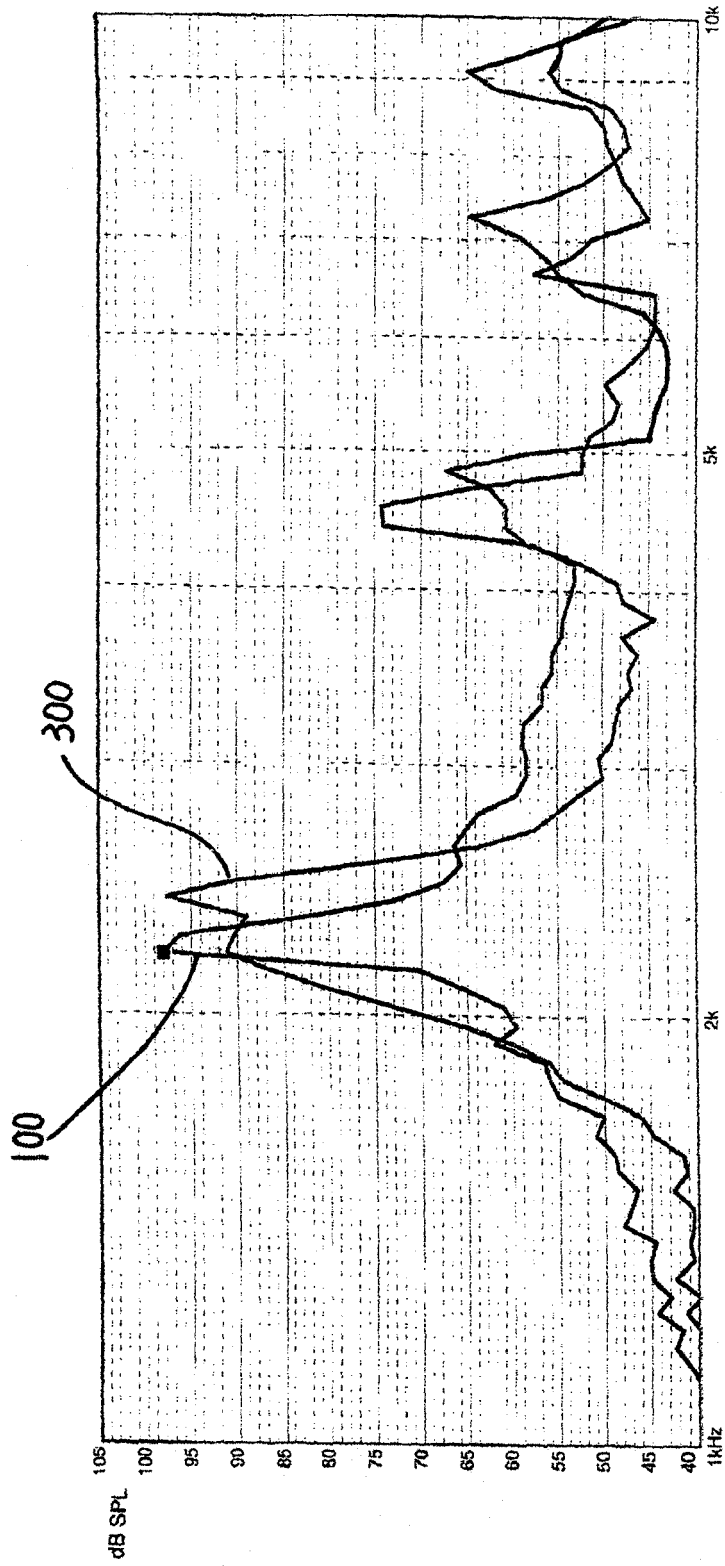

FIGURE 21

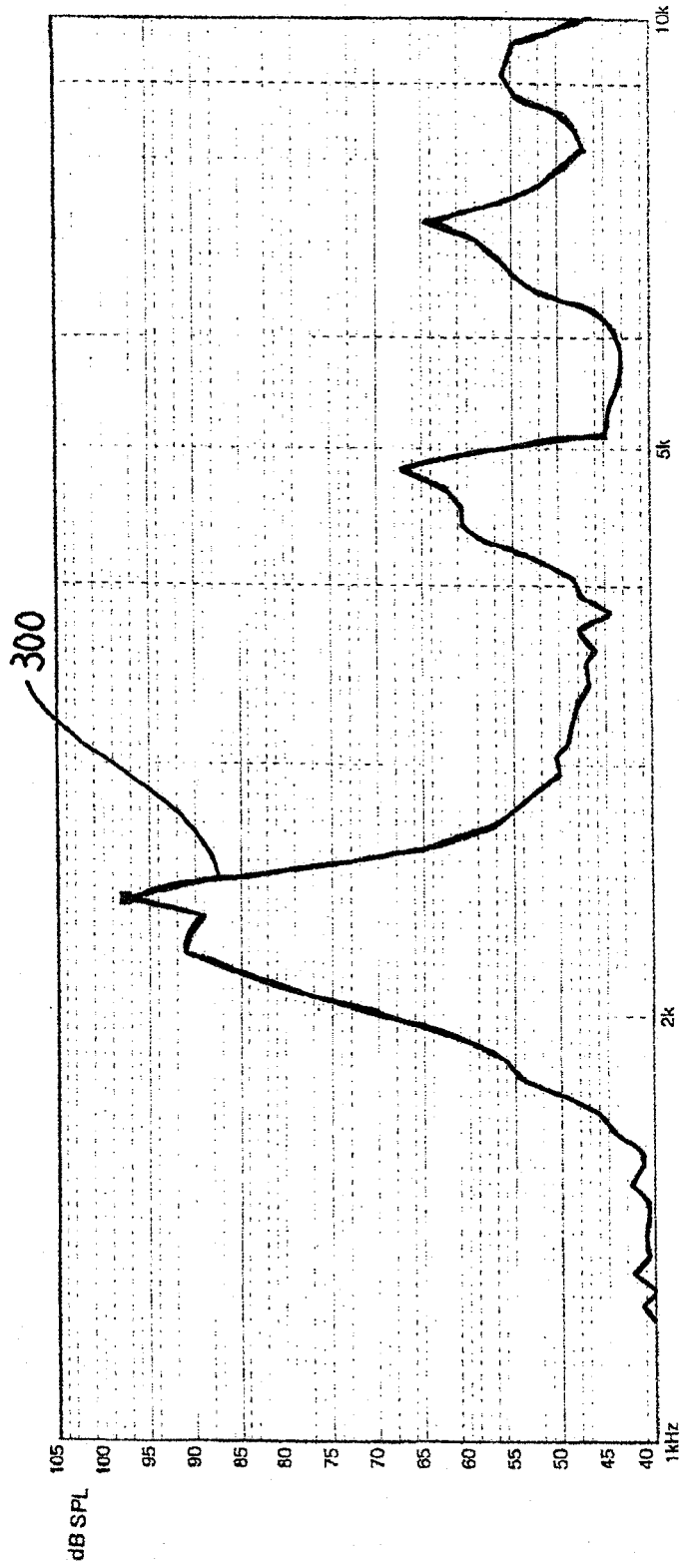

FIGURE 22

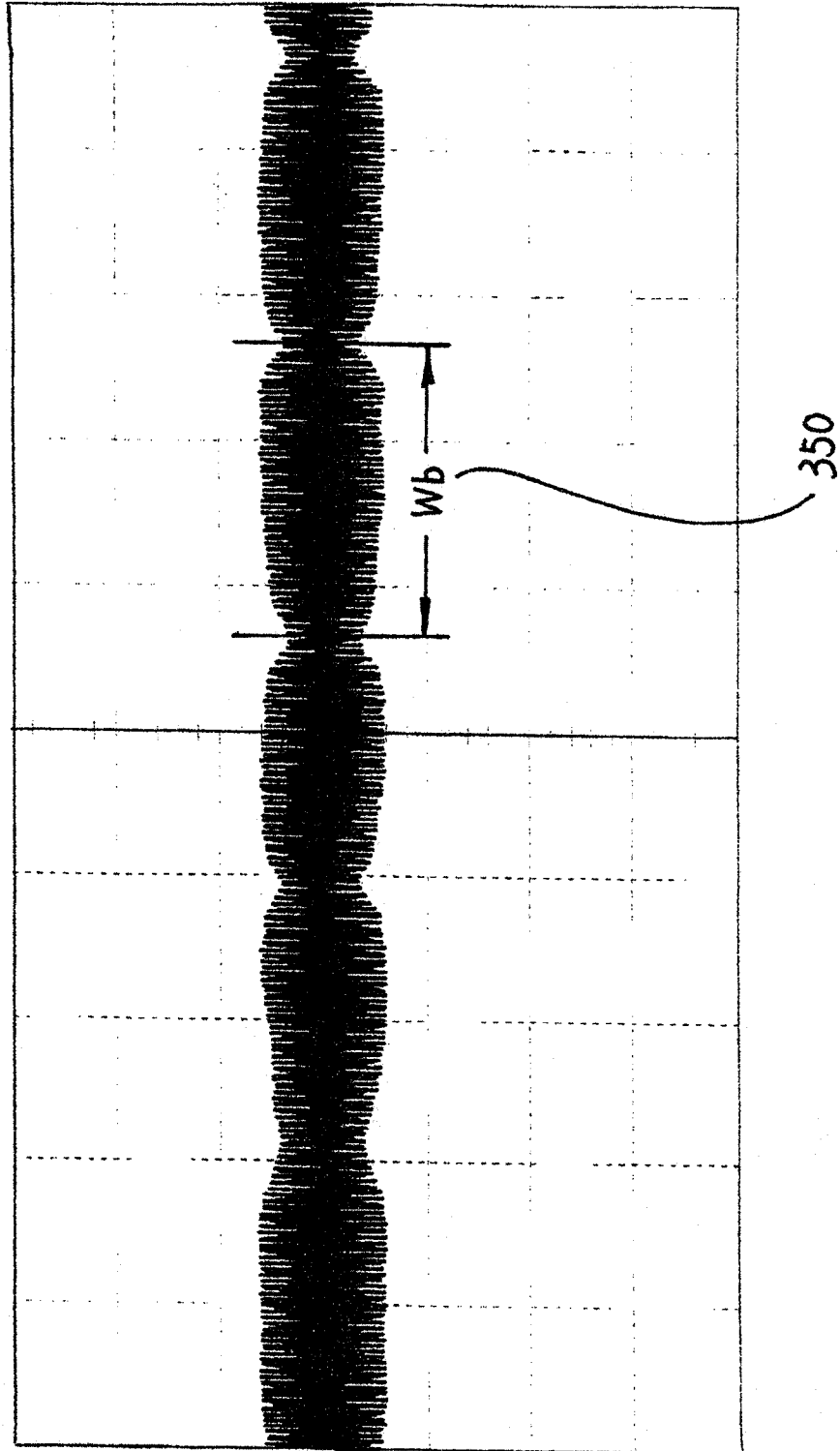

FIGURE 23

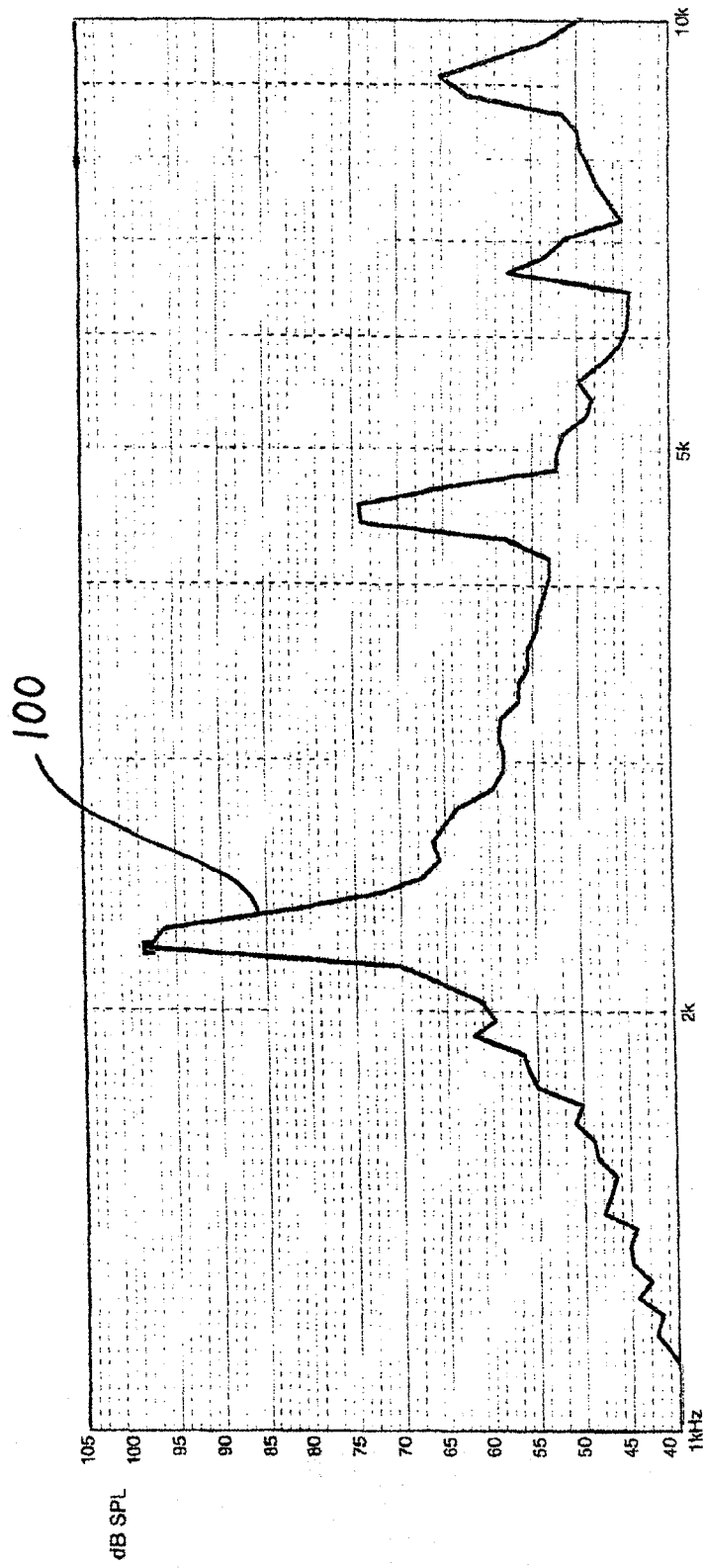
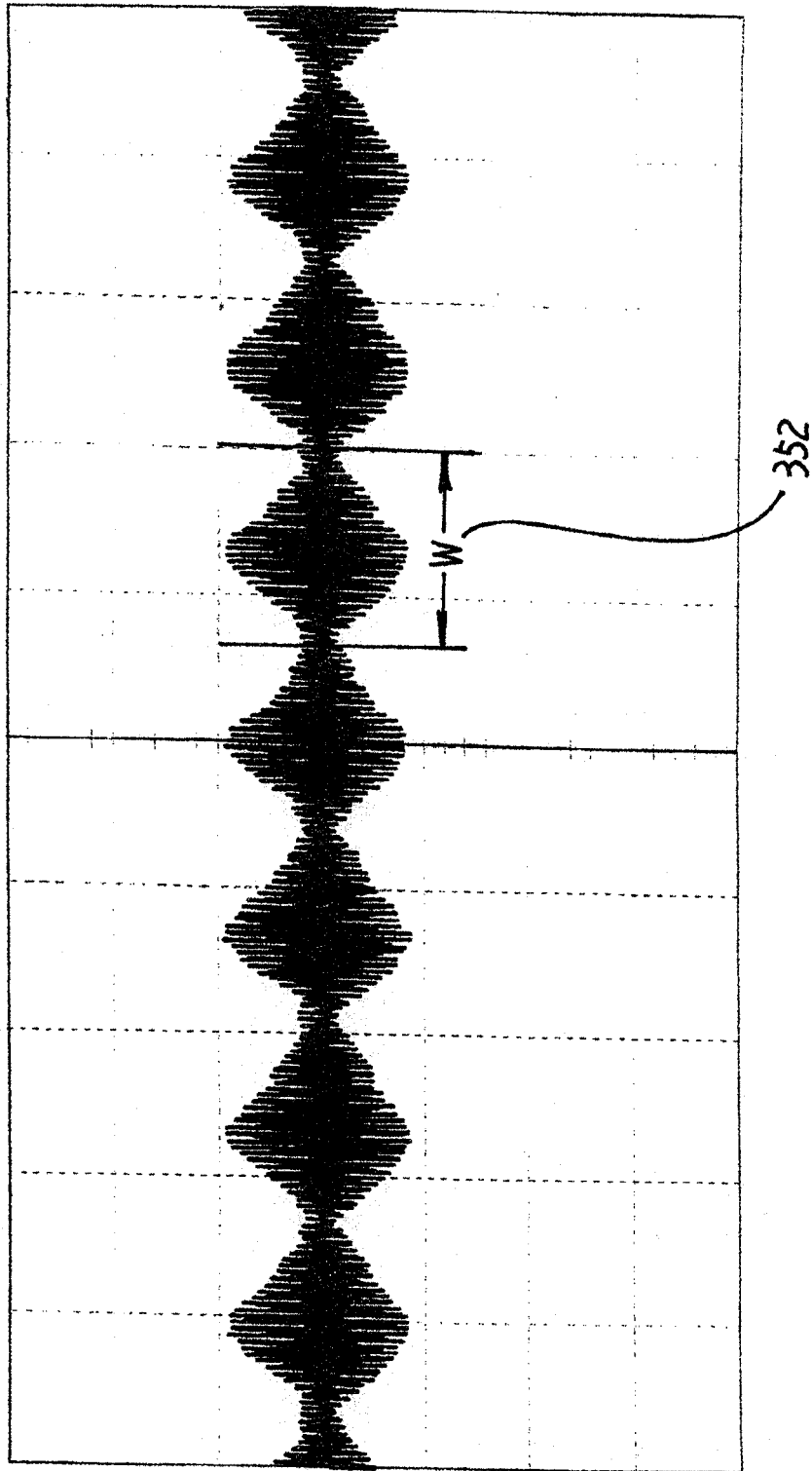
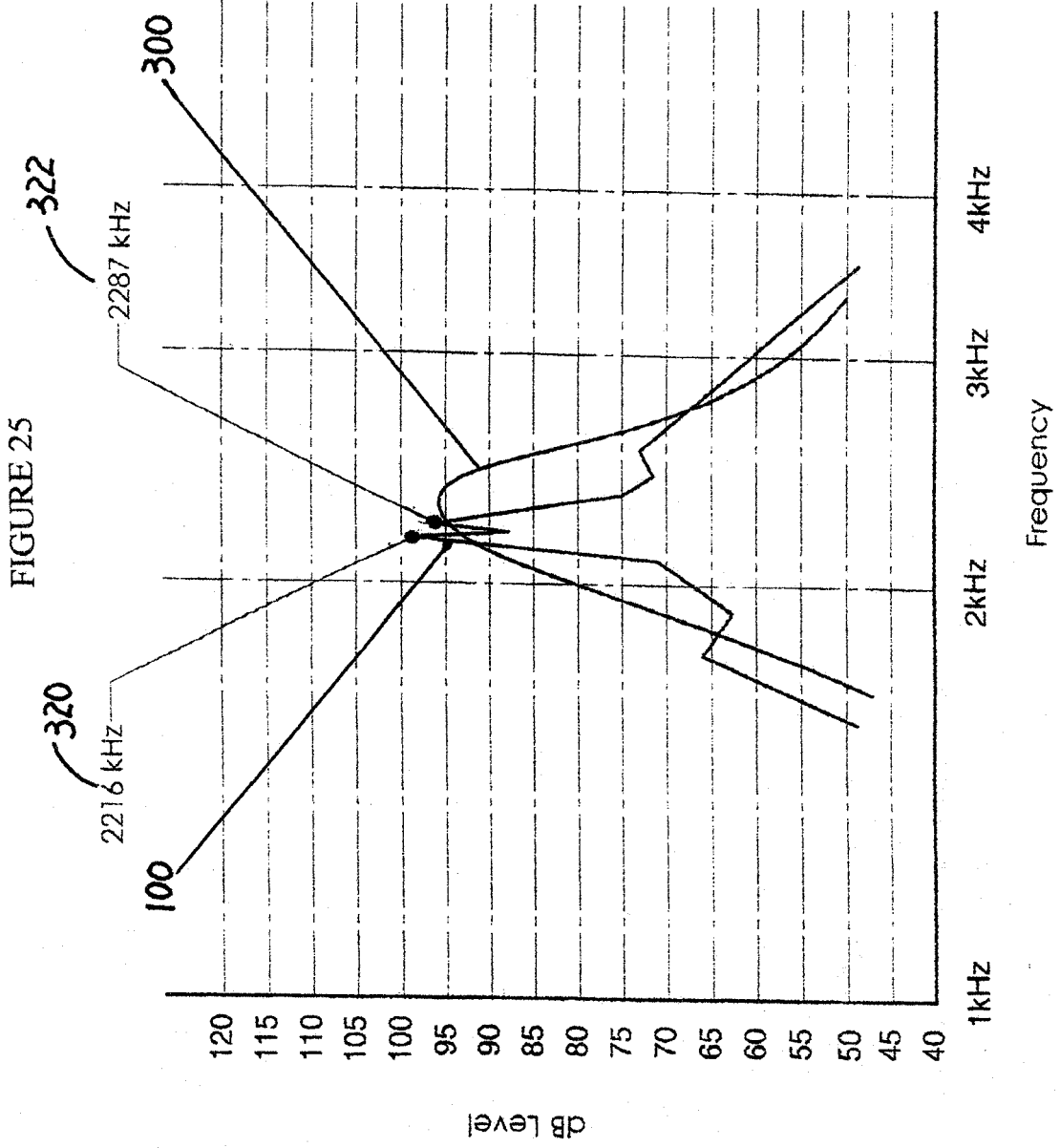

FIGURE 24







EUROPEAN SEARCH REPORT

Application Number
EP 10 18 0479

DOCUMENTS CONSIDERED TO BE RELEVANT				
Category	Citation of document with indication, where appropriate, of relevant passages	Relevant to claim	CLASSIFICATION OF THE APPLICATION (IPC)	
X	US 2002/017231 A1 (TANAKA MASAYUKI [JP]) 14 February 2002 (2002-02-14) * paragraphs [0005], [0013] - [0018], [0035], [0036], [0039], [0044], [0052], [0053] * * figures 2,5,14,15 *	1-10	INV. G10K5/00	
X	US 5 816 186 A (SHEPHERD CHARLES G [CA]) 6 October 1998 (1998-10-06) * column 1, line 40 - line 45 * * column 2, line 42 - line 61 * * column 3, line 20 - line 30 * * figures 1,3 *	1		
X	US 2009/272310 A1 (SHISHIDO HIDEOMI [JP]) 5 November 2009 (2009-11-05) * paragraphs [0013], [0021] - [0023], [0040], [0041], [0048], [0049], [0052] * * figures 2,5 *	1,8-10		
A	EP 0 302 645 A2 (FORTRON INC [CA]) 8 February 1989 (1989-02-08) * column 4, line 24 - line 52 * * column 5, line 2 - line 32 *	1-10		TECHNICAL FIELDS SEARCHED (IPC)
A	US 3 277 861 A (MOE LOWELL A) 11 October 1966 (1966-10-11) * column 4, line 67 - column 5, line 2 * * column 8, line 73 - column 9, line 4 *	1-10		G10K
The present search report has been drawn up for all claims				
Place of search Munich		Date of completion of the search 16 November 2010	Examiner Schneiderbauer, K	
CATEGORY OF CITED DOCUMENTS X : particularly relevant if taken alone Y : particularly relevant if combined with another document of the same category A : technological background O : non-written disclosure P : intermediate document		T : theory or principle underlying the invention E : earlier patent document, but published on, or after the filing date D : document cited in the application L : document cited for other reasons & : member of the same patent family, corresponding document		

1
EPO FORM 1508 03.82 (P04C01)

ANNEX TO THE EUROPEAN SEARCH REPORT
ON EUROPEAN PATENT APPLICATION NO.

EP 10 18 0479

This annex lists the patent family members relating to the patent documents cited in the above-mentioned European search report. The members are as contained in the European Patent Office EDP file on
The European Patent Office is in no way liable for these particulars which are merely given for the purpose of information.

16-11-2010

Patent document cited in search report	Publication date	Patent family member(s)	Publication date
US 2002017231 A1	14-02-2002	DE 10135890 A1	18-04-2002
		JP 3563046 B2	08-09-2004
		JP 2002108345 A	10-04-2002
		TW 554333 B	21-09-2003

US 5816186 A	06-10-1998	NONE	

US 2009272310 A1	05-11-2009	DE 102009019431 A1	05-11-2009
		JP 2009271214 A	19-11-2009

EP 0302645 A2	08-02-1989	AU 603928 B2	29-11-1990
		AU 2244588 A	29-03-1990
		CA 1276822 C	27-11-1990
		CN 1031419 A	01-03-1989
		DE 3875023 D1	05-11-1992
		DE 3875023 T2	04-03-1993
		ES 2035924 T3	01-05-1993
		JP 1065598 A	10-03-1989
		JP 2009727 C	02-02-1996
		JP 7027385 B	29-03-1995
		US 4821670 A	18-04-1989

US 3277861 A	11-10-1966	NONE	

REFERENCES CITED IN THE DESCRIPTION

This list of references cited by the applicant is for the reader's convenience only. It does not form part of the European patent document. Even though great care has been taken in compiling the references, errors or omissions cannot be excluded and the EPO disclaims all liability in this regard.

Patent documents cited in the description

- US 61371227 B [0001]
- US 5816816 A [0005]
- US 4821670 A [0005]
- US 6837177 B [0009]
- US 4709651 A [0009]
- US 5816186 A [0010]