

(19)



(11)

**EP 2 420 217 A1**

(12)

**EUROPEAN PATENT APPLICATION**

(43) Date of publication:  
**22.02.2012 Bulletin 2012/08**

(51) Int Cl.:  
**A61H 1/02 (2006.01) A63B 23/04 (2006.01)**

(21) Application number: **11189770.8**

(22) Date of filing: **25.12.2007**

(84) Designated Contracting States:  
**AT BE BG CH CY CZ DE DK EE ES FI FR GB GR HU IE IS IT LI LT LU LV MC MT NL PL PT RO SE SI SK TR**

(30) Priority: **25.12.2006 JP 2006348637**  
**25.09.2007 PCT/JP2007/068558**

(62) Document number(s) of the earlier application(s) in accordance with Art. 76 EPC:  
**07860079.8 / 2 098 208**

(71) Applicant: **Panasonic Electric Works Co., Ltd.**  
**Kadoma-shi**  
**Osaka 571-8686 (JP)**

(72) Inventors:  
• **Ochi, Kazuhiro**  
**Kadoma-shi, Osaka 571-8686 (JP)**

- **Shinomiya, Youichi**  
**Kadoma-shi, Osaka 571-8686 (JP)**
- **Ozawa, Takahisa**  
**Kadoma-shi, Osaka 571-8686 (JP)**
- **Goto, Takao**  
**Kadoma-shi, Osaka 571-8686 (JP)**
- **Saitou, Atsuhiro**  
**Kadoma-shi, Osaka 571-8686 (JP)**
- **Sugai, Haruo**  
**Hikone-shi, Shiga 522-0002 (JP)**

(74) Representative: **Appelt, Christian W.**  
**Forrester & Boehmert**  
**Pettenkoflerstrasse 20-22**  
**80336 München (DE)**

Remarks:

This application was filed on 18-11-2011 as a divisional application to the application mentioned under INID code 62.

(54) **Exercise assisting device**

(57) A housing 1 is provided with a left foot support 2a and the right foot support 2b each of which is provided for bearing the user's foot thereon. A drive unit 3 is configured to vary an upper surface angle of each of the left foot support, 2a and the right foot support relative to horizontal plane. Each of the left foot support 2a and the right foot support 2b is driven to move within a swing range. When one of the left foot support 2a and the right foot support 2b has its front end being located at an upper end of the swing range, the other of the left foot support 2a and the right foot support 2b has its front end being located at a lower end of the swing range. Both of a left ankle joint and a right ankle joint are alternately dorsiflexed and plantarflexed. Consequently, it is possible to obtain an exercise assisting device being configured to bend and stretch lower legs to stimulate lower leg muscles.

Fig 2

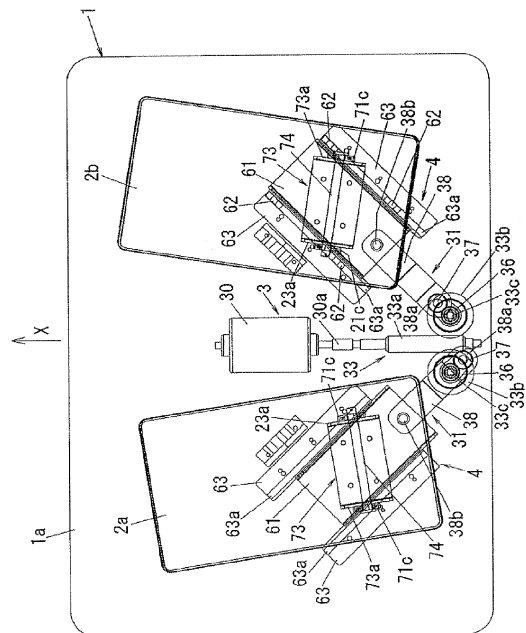

**EP 2 420 217 A1**

## Description

### TECHNICAL FIELD

**[0001]** This present invention relates to an exercise assisting device which assists a user to stretch ones leg muscles with an aid of external forces mainly in a standing posture.

### BACKGROUND ART

**[0002]** In the past, there have been proposed various types of exercise assisting devices which assist a user to stretch ones muscles without effort but with an aid of external forces being applied to the user in order to give an exercise effect. The devices are known to be classified into two types, one being configured to apply a force of bending joints of the user for stretching the muscles associated with the joints, and the other configured to apply a stimulus to a user's body to cause a nervous reflex by which associated muscles are forced to stretch.

**[0003]** Further, the devices are designed to require the user to take different postures depending upon the muscles to be stretched. One example of the devices is to simulate a walking by the user at a standing posture mainly for the purpose of preventing osteoarthritis or walk-training, as proposed in JP 2003-290386. Hereinafter, JP 2003-290386 is called as PATENT DOCUMENT 1.

**[0004]** PATENT DOCUMENT 1 discloses a training device which includes a pair of steps bearing thereon left and right feet of the user, and is configured to interlock the reciprocating movements of the left and right steps for providing a skating simulation exercise to the user. The device is designed to adjust a phase difference of 0 to 360 degrees between the left and right steps with regard to the forward/rearward movements as well as to the lateral movements, and is initially set to have the phase difference of 180 degrees and to vary the phase difference in a direction of increasing a period in which the left and right steps moves forward/rearward together. The steps are driven by a driving mechanism to move so that the user can enjoy the passive exercise simply by placing one's feet on the steps and without making an effort or active movement.

**[0005]** Further, the device of PATENT DOCUMENT 1 is arranged to shift the user's weight along forward/rearward direction and also along lateral direction such that the user makes the use of one's nervous reflex to keep a balance with an effect of stretching the muscles. The steps are caused to move substantially in parallel with each other so that the weight of the user shifts simultaneously in the forward/rearward direction and the lateral direction.

**[0006]** However, in the configuration of PATENT DOCUMENT 1, it is not possible to adjust a various range of an angle of an ankle's joint to a desired angle. For example, when the various range of the angle of the ankle's joint becomes larger, an effect of stretching the leg mus-

cles such as gastronemius muscle becomes larger. Therefore, it is possible to increase venous flow. However, the device in PATENT DOCUMENT 1 is not capable of providing such effect sufficiently. In addition, dorsiflexion and plantarflex of the ankle's joint is caused according to frontward/rearward movement in walking, while the various angle of the ankle's joint becomes smaller comparatively. Such a motion which links the movement of the foot in walking to the various angle of the ankle's joint is not realized by the device in PATENT DOCUMENT 1. Therefore, it is impossible for the exercise assisting device in PATENT DOCUMENT 1 to train cooperativeness between the muscles in rehabilitation training.

### 15 DISCLOSURE OF THE INVENTION

**[0007]** The invention is achieved to solve the above problem. An object in this invention is to provide an exercise assisting device. The exercise assisting device in this invention is configured to stimulate leg muscles as well as to stimulate lower leg muscles by bending and stretching the ankle joint.

**[0008]** To solve the problem, the exercise assisting device comprises a left foot support, a right foot support, a drive unit, and a frame. The left foot support and the right foot support are respectively configured to bear a user's left foot and right foot. The drive unit is configured to displace at least one of the left and right foot supports. The frame is configured to mount the left and the right foot supports and the drive unit. Each of the left and right foot supports is arranged to prescribe a foot position on which the foot is placed. The drive unit includes a swing drive which is configured to vary an angle of a top surface angle of at least one of the left and right foot supports relative to the frame for varying an ankle joint angle.

**[0009]** In this case, the exercise assisting device comprises the swing drive which is configured to vary the top surface angle of at least one of the left and right foot supports relative to the top plane of the frame in order to vary ankle joint angle. Therefore, the swing drive makes it possible to bend and stretch the ankle joint by varying the top surface angle of at least the left foot support and the right foot support. Consequently, it is possible to stimulate lower leg muscles such as gastrocnemius muscles by plantarflexing and dorsiflexing the ankle joint. Expansion and contraction of the lower leg muscles facilitates venous flow. Therefore, the expansion and the contraction of the lower leg muscles facilitates the flow of blood. In addition, the exercise assisting device allows the ankle joint to bend and stretch. Therefore, the exercise assisting device is capable of improving motion range of the ankle joint of the user who stands on the left foot support and the right foot support. In short, previously, a training of improving motion range of the ankle joint requires human resources. However, the exercise assisting device makes it possible to improve the motion range of the ankle joint by oneself, not requiring human resources.

**[0010]** Also to solve the problem, the passive exercise

assisting device comprises a left foot support, a right foot support, a drive unit, and a frame. The left foot support and the right foot support respectively configured to bear a user's left foot and right foot. The drive unit is configured to displace at least one of the left and right foot supports. The frame is configured to mount the left and right foot supports and the frame. Each of the left and right foot supports is arranged to prescribe a foot position on which the foot is placed. The drive unit includes a slide drive and a swing drive. The slide drive is configured to slide the left and right foot supports along a movement plane defined on the side of the frame. The swing drive is configured to vary a top surface angle of at least one of the left and right foot supports relative to a top plane of the frame for varying the ankle joint angle.

**[0011]** With this configuration, the exercise assisting device comprises the slide drive and the swing drive. The slide drive is configured to slide at least one of the left and right foot supports. The swing drive is configured to vary the top surface angle of at least one of the left and right foot supports so as to vary ankle joint angle. Therefore, the exercise assisting device is capable of applying the passive exercise to user's leg muscle in order to stimulate the user's leg muscle by the slide drive which slides at least one of the left foot support and the right foot support. In addition, the swing drive is configured to vary at least one of the top surface angle of the left foot support and the right foot support in order to bend and stretch the user's ankle joint. Therefore, the exercise assisting device is configured to stimulate the lower leg muscles such as gastrocnemius by planerflexing and dorsiflexing the user's ankle joint. The expansion and the contraction of the leg muscles increase the venous flow, thereby leading to improvement of increase of blood circulation. Further, the exercise assisting device bends and stretches the ankle joint by the passive exercise, the device is capable of applying load to the ankle joint of the user in the standing posture by using the user's center of gravity. The load allows the ankle joint to improve the range of the ankle joint. That is, previously, human resources is required to improve the motion range of the ankle joint, However, the exercise assisting device makes it possible to improve the motion range of the ankle joint by oneself. At the same moment, the exercise assisting device allows the ankle joints to bend and stretch in accordance with the slide of the left foot support and the right foot support. Consequently, the exercise assisting device with this configuration allows the user to positively expand and contract the user's ankle joint, and allows the user to exercise similar to walking training.

**[0012]** It is preferred that the swing drive is configured to swing at least one of the left and right foot supports about a predetermined axle for varying the top surface angle relative to a top plane of the frame. The axle is positioned to have its axis extending through the ankle joint.

**[0013]** With this configuration, the axle is disposed to have its extended line passing through the ankle joint.

Therefore, at least one of the left foot support and the right foot support swings about a swing center of the axle which approximately corresponds to a swing center of the ankle joint, and the knee joint does not bend without moving the ankle joint upward and downward while swinging. Consequently, it is possible to reduce the load applied to the ankle joint and the knee joint. In addition, the exercise assisting device allows the gastrocnemius to expand and contract as well as allows the ankle joint to bend and stretch. Therefore, the exercise assisting device is configured to strengthen the lower leg muscle and to improve the range of ankle joint.

**[0014]** It is preferred that the swing drive is configured to swing at least one of the left and right foot supports about a predetermined axle for varying the top surface angle relative to a top plane of the frame. The axle is positioned immediately below the ankle joint.

**[0015]** With this configuration, the axle is disposed below the ankle joint, and is disposed to pass through the position immediately below the ankle joint. Therefore, it is possible to dispose the drive unit below the left foot support and the right foot support. Therefore, this configuration makes it possible for the exercise assisting device to have no projection which lies on an upper of the left foot support and the right foot support. Consequently, it is possible to provide the exercise assisting device of thin shape. Further, this exercise assisting device houses the above components which are arranged easily to manufacture. Therefore, it is possible to provide the exercise assisting device which is inexpensive. Although the position of the ankle joint moves upward and downward when at least one of the left foot support and the right foot support swings about the axle, distance between the axle and the ankle joint is designed to have a minimum distance, while the axle which extend immediately below the ankle joint being arranged below the left foot support and the right foot support. Therefore, it is possible to minimize the load applied to the ankle joint.

**[0016]** It is preferred that the swing drive is configured to swing at least one of the left and right foot supports about a predetermined axle for varying the top surface angle relative to a top plane of the frame. The axle is positioned below the foot bottom and offset forward or rearward relative to the ankle joint.

**[0017]** With this configuration, the exercise assisting device has the axle being disposed below the foot bottom to be located at a position offset forward or rearward to the ankle joint. Therefore, it is possible to dispose the drive unit being located lower than the left foot support and the right foot support. Therefore, this configuration makes it possible for the exercise assisting device to have no projection which lies on an upper of the left foot support and the right foot support. Consequently, it is possible to provide the exercise assisting device having thin shape. Further, the exercise assisting device with this configuration is configured to have components which are easily arranged. Therefore, it is possible to provide the exercise assisting device which is inexpensive. In addition, the

swing drive swings at least one of the left foot support and the right foot support about the axle so as to move the ankle joint upward and downward. Therefore, the exercise assisting device allows the left ankle joint to have height which is different from height of the right ankle joint. Therefore, the exercise assisting device causes reflex to keep balance in a lateral direction by the knee joint, hip joint, and upper body. As a result, the exercise assisting device is capable of applying stimulation to the muscles of the knee joint, the hip joint, and the upper body.

**[0018]** It is preferred that the swing drive is configured to swing at least one of the left and right foot supports about a predetermined axle for varying the top surface angle relative to top plane of the frame. The swing drive is configured to vary a vertical position of the axle in accordance with the varying top surface angle.

**[0019]** In this case, the swing drive moves the axle to vary vertical position according to the angle variation of at least one of the left foot support and the right foot support, thereby varying vertical position of the ankle joint. Therefore, the exercise assisting device allows the left ankle joint to have height which is different from height of the right ankle joint so as to cause the reflex to keep balance in the lateral direction by the knee joint, the hip joint, and the upper body. As a result, the exercise assisting device is capable of applying the stimulation to the muscles of the knee joint, the hip joint, and the upper body.

**[0020]** It is also preferred that the foot position is prescribed to put toe of the user's left foot on the left side away from its heel for the left foot support. The foot position is prescribed to put toe of the user's right foot on the right side away from its heel for the right foot support. The swing drive is configured to vary the top surface angle of each of the left and right foot supports relative to the top plane of the frame in a movable direction about the ankle joint of the user's foot held in the prescribed position.

**[0021]** With this configuration, distance between the left toe and the right toe is larger than distance between the left heel and the right heel in a condition where the user uses the exercise assisting device with the standing posture on the left foot support and the right foot support. Therefore, the user is able to stand on the left foot support and the right foot support with releasing tension, thereby the user is able to use the exercise assisting device without receiving shearing force to the knee joint and the ankle joint. The left foot support and the right foot support respectively have its top surfaces angle. The swing drive varies at least one of the top surface angles toward a movable direction of the foot around the ankle joint. Therefore, the exercise assisting device applies no shearing force to the ankle joints when the angle of the left foot support and the right foot support is varied, thereby the user being able to use the exercise assisting device with low load to the ankle joint.

**[0022]** It is also preferred that each of the left foot sup-

port and the right foot support is provided with positioning means. This positioning means prompts the placement of the user's foot on the prescribed position.

**[0023]** With this configuration, the positioning means of the left foot support and the right foot support prompt the placement of the user's foot. Therefore, this configuration makes it possible to apply no shearing force to the ankle joint. The user is able to use the exercise assisting device with the low load applied to the ankle joint.

**[0024]** It is preferred that the slide drive is configured to reciprocate the left and right foot supports in a forward/rearward direction respectively along individual travel paths, while varying a lateral distance between the left and right foot supports with regard to representative points of the left and right foot supports. The lateral distance between forward ends of the travel paths differ from the lateral distance between rearward ends of the travel paths.

**[0025]** With this configuration, the slide drive is configured to move the foot position forward/rearward while the foot position moves leftward/rightward. Further, the left foot support and the right foot support respectively have travel paths. The lateral distance between front ends of the travel paths is different from lateral distance between rear ends of the travel paths. Therefore, to configure the travel paths along the proper line, the shearing force applied to the knee ankle is lower than shearing force applied to the knee ankle in a condition where the left foot and the right foot are respectively moves toward front direction. Besides, moving directions of the foot positions cross with the front direction of the user. When the foot position is moved along this moving direction, the expansion and the contraction of the muscles of the lower legs is increased. Therefore, the exercise assisting device moves the foot position along the moving direction to cause venous flow which is larger than venous flow that the foot position is moved along the forward/rearward direction. As a result, it is possible to relieve the swelling of the calves and to relieve venostasis by stimulating the blood circulation to distal portion. Further, the exercise assisting device allows the leg joint to bend and stretch to expand and contract the gastrocnemius, thereby the venous flow is further stimulated.

**[0026]** In general, the forward/rearward movement of the foot causes stimulation of rectus femoris, vastus medialis, vastus lateralis, biceps femoris, anterior tibialis, and gastrocnemius. The lateral movement of the foot causes stimulation of adduct muscles and abduct muscles. This exercise assisting device generates combination movement of the forward/rearward direction and the lateral direction. Therefore, this exercise assisting device is capable of stimulating the muscles with cooperation and comprehensively. In this manner, the exercise assisting device expands and contracts muscles to facilitate uptake of sugar into the muscles so as to improve the Type 2 diabetes of the user. In addition, this exercise assisting device is capable of stimulating the deep muscle such as long muscles of a thumb which is

little expanded and contracted by only the forward/rearward movement or the lateral movement of the foot. Furthermore, the exercise assisting device is configured to bend and stretch the lower leg muscle mainly. Therefore, the exercise assisting device is expected to bring down blood pressure of hypertensive user. And user who has heard disease is able to use the exercise assisting device because the exercise assisting device applies the low load to the user.

**[0027]** It is preferred that the slide drive includes a moving direction determiner which is configured to adjust an angle of the travel path relative to the forward/rearward direction. The travel path extends linearly and is defined by a line connecting the forward end and the rearward end of the representative points.

**[0028]** In this case, the left foot support and the right foot support is driven to move along the linear travel paths, thereby the left foot support and the right foot support applying no force of twisting the knee joint and ankle joint. Therefore, it is possible for user to use the exercise assisting device with low load of the knee joint and ankle joint. Furthermore, the slide drive moves the left foot support and the right foot support to direct advance, thereby mechanisms for moving the left foot support and the right foot support being simply constructed. Furthermore, it is possible to reduce the shearing force applied to the knee joint by arranging the travel paths to have V-shape with opened front end to make angle of 5 to 15 degrees. The exercise assisting device with the travel path being arranged to make approximately 45 degrees is configured to apply load to the adducent muscles, the abducent muscles, and the muscles for bending and stretching the knee joint in order to strengthen the adducent muscles, the abducent muscles, and the muscles for bending and stretching the knee joint. Furthermore, it is also possible to arrange travel paths to form V-shape with opened rear end. In this case, it is possible to obtain the exercise assisting device being configured to expand and contract femoral muscles as well as lower leg muscles.

**[0029]** It is preferred that the slide drive is configured to move the left and right foot supports in an opposite phase relation along the forward/rearward direction so as to keep a center of gravity of the user at a constant position in the forward/rearward direction.

**[0030]** With this configuration, the exercise assisting device is configured to keep the center of gravity of the user in the forward/rearward direction at the constant position. Therefore, acceleration is not applied to the user's upper body. The exercise assisting device with this configuration makes it possible to prevent the user from losing balance. Consequently, this exercise assisting device is capable of being used by user whose balance function is atrophied. In addition, the left and right foot positions are alternately moved forward/rearward so as to apply the user to motion which is similar to walk motion. Furthermore, it is possible to stimulate muscles with low load. Therefore, the exercise assisting device is capable of stimulating cerebral nerve highly. This exercise assisting

device is expected to apply high recovery effect for user who has impaired brain function and who receives operation on the brain.

## 5 BRIEF DESCRIPTION OF THE DRAWINGS

### [0031]

10 Fig. 1 (a) is a schematic perspective view of the exercise assisting device in a first embodiment.

Fig. 1 (b) is a side view of the left foot support and the right foot support explaining the motion thereof. Fig. 2 is a planer view of the above without top plate. Fig. 3 (a) to (d) are cross sectional view of the positioning means of the above.

15 Fig. 4 is a schematic diagram of the drive unit of the above.

Fig. 5 is an explanation drawing of the main parts of the above.

20 Fig. 6 is an explanation drawing of the main parts explaining the usage example.

Fig. 7 is an exploded perspective view of the drive unit of the second embodiment.

25 Fig. 8s are explanation drawings of the driving unit. Fig. 9 is another explanation of operation of the above.

Fig. 10 is an explanation drawing showing the operation of the exercise assisting device in Fig. 11 is yet another explanation of operation of the above.

30 Fig. 12 is an explanation drawing showing the operation of the exercise assisting device in Fig. 13 is an exploded perspective view of the drive unit of the above.

35 Fig. 14 (a) to (c) are explanation drawings showing the above drive unit.

Fig. 15 is a schematic view of the main parts in fourth embodiment.

Fig. 16 is a schematic view of the main parts in fifth embodiment.

40 Fig. 17 is another explanation view showing the operation of the left foot support and the right foot support.

Fig. 18 is yet another explanation view of the left foot support and the right foot support.

45 Fig. 19 is yet another explanation view of the left foot support and the right foot support.

## BEST MODE FOR CARRYING OUT THE INVENTION

50 (First embodiment)

**[0032]** Although the present embodiment illustrates a device adapted in use to be placed on a floor, the device can be used with its portion embedded in the floor. A selection is made as to whether the device is placed at a fixed position or movably supported. In this embodiment, as shown in Fig. 1 and 2, the exercise assisting device comprises a housing for being placed on the floor.

The housing 1 is designed to have a rectangular parallelepiped shape. The illustration show a base plate 1a is shown as the housing 1. However, the housing 1 is not limited to the rectangular parallelepiped shape. For a simplified explanation made hereinafter, the housing 1 is illustrated to have a top surface parallel to the floor when it is placed on the floor. Therefore, upper and lower in Fig. 1 indicate an upper side and the lower side in use respectively. When used with a portion embedded in the floor, the housing 1 may have a frame structure except for the upper plate 1 b.

**[0033]** The housing 1 is provided with a left foot support 2a and a right foot support 2b adapted respectively for bearing left and right feet of a user. Also, a drive unit 3 is disposed in the housing 1 for moving the left and right foot supports 2a and 2b individually. The left foot support 2a and the right foot support 2b have top surfaces which are respectively formed to have such dimension as to bear the entire foot of the user. It is noted that an arrow X in Fig. 1 denotes a forward direction of the device. This applies to any other figure which includes the arrow X.

**[0034]** The device is basically designed for use by a user in a standing posture, although it can be used by a user in a sitting posture. Therefore, hereinafter, the device is explained in a condition where the device is used by the user at the standing posture with one's feet placed on the left and right foot supports 2a and 2b.

**[0035]** An upper plate 16 is disposed above the base plate 1a. The upper plate 1b is cooperative with the base plate 1 a to constitute a housing 1. The upper plate 1b is formed with two openings 11 a and 11 b extending in a thickness direction of the plate to expose the left and right foot supports 2a and 2b, respectively. The openings 11a and 11b are each formed into a rectangular shape. The openings 11a and 11b have their longitudinal center lines extending in a crossing relation with respect to the forward/rearward direction of the housing 1 such that the distance between the longitudinal center lines is greater at the front ends of the openings than at the rear ends thereof. The longitudinal direction of each of the openings 11a and 11b is inclined at a suitable angle relative to the forward/rearward direction of the base plate 1 a. However, it is preferred that the longitudinal direction of each of the openings 11a and 11b is inclined at 5 to 15 degrees relative to the forward/rearward direction of the base plate 1a, for example. The angle made at the meeting of the longitudinal center line of the left opening 11a and the forward/rearward direction of the base plate 1a is counterclockwise angle about its rear end. The angle made at the meeting of the longitudinal center line of the right opening 11b and the forward/rearward direction of the base plate 1a is clockwise angle about its rear end.

**[0036]** Each of the openings 1 a and 11 b has an open area greater than the top surface area of each of the left and right foot supports 2a and 2b, so that the left and right foot supports 2a and 2b is movable respectively within the openings 11 a and 11b. The left foot support 2a and the right foot support 2b are respectively provided

at its entire circumference with cover plates 12 for concealing gaps between the each of the left and right foot support 2a, 2b and the openings 11a, 11b so as not to make gap between the left and right foot support 2a, 2b and the openings 11 a, 11 b while the left foot support 2a and the right foot support 2b is driven to move within the openings 11a, 11b.

**[0037]** The openings 11a and 11b have their lengthwise directions respectively aligned with the longitudinal directions of the left and right foot supports 2a and 2b. In use, the user places one's feet on the left and right foot supports with each of the longitudinal center lines of the feet aligned with the lengthwise direction of each foot support. Therefore, as mentioned in the above, the openings 11a and 11b have their individual lengthwise center lines angled at 5 degrees to 15 degrees relative to the forward/rearward direction of the housing 1, such that the user in the standing posture can place the feet respectively on the left and right foot supports 2a and 2b with one's leg muscles kept relaxed.

**[0038]** Both of the left foot support 2a and the right foot support 2b has its bottom integrally formed with a pair of bearings. One bearing in the left foot support 1a is spaced along a width direction of the other bearing in the left foot support 1a. One bearing in the right foot support 1b is spaced along a width direction of the other bearing in the right foot support 1 b. Attachment plates, not shown in the illustrations, are arranged below the left foot support 2a and the right foot support 2b. This attachment plates are overlapped with the left foot support 2a and the right foot support 2b. A bearing plate 73 of U-shaped cross section is fixed to the top of the attachment plate to have its open end oriented upwardly, and has its opposed legs 73a in contact respectively with the outer faces of the bearing 73c of the left foot support 2a and the right foot support 2b. An axle 74 penetrates through the legs 73a of the bearing plate 73 and the bearings 71c to extend in the width direction of both of the left foot support 2a and the right foot support 2b. The left foot plate 2a and the right foot plate 2b are allowed to swing about the axle 74 in such a manner that the left foot plate 2a and the right foot plate 2b move up and down at its lengthwise forward and rearward ends.

**[0039]** A truck 61 of U-shaped cross section has its open end. The truck 61 is fixed to the bottom of the attachment plate to have the open end downwardly. The truck 61 is provided on each exterior face of its legs 61 a with two wheels 62. The base plate 1 a has upper end being formed with two fixed rails 63 for each of the left and right foot support 2a and 2b such that the truck 61 is placed on the rails 63 with the wheels 62 roll in the rail grooves 63a in the upper end of the rails 63.

**[0040]** The rails 63 extend in a direction different from the lengthwise direction of the openings 11a and 11 b in the housing 1. As described in the above, the openings 11a and 11b have their individual longitudinal center lines crossed with each other so as to be spaced by a larger distance at the forward ends than at the rearward ends.

Also, the rails 63 have their individual longitudinal directions crossed with each other in the like manner.

**[0041]** The rails 63 are inclined in relation to the forward/rearward direction of the housing 1 at a large angle than the openings 11 a and 11 b. For example, when the openings 11a and 11b have their lengths inclined relative to the forward/rearward direction of the housing 1 at an angle of 30 degrees, the rails 63 have its length inclined at an angle of 45 degrees. In short, the rails 63 are oriented to such a direction as to prevent an increase of shearing force acting on the knee joints while the left and right foot supports 2a and 2b are moved along the rails 63 in a condition that the user's feet are placed thereon with each center line of the feet aligned with each of the length of the openings 11a and 11 b. It is noted that this embodiment shows the exercise assisting device having the left foot support 2a and the right foot support 2b which are respectively configured to move along the combined travel path of the forward/rearward direction with the lateral direction. However, it is possible to move the left foot support 2a and the right foot support 2b along the rail 63 which is oriented to the forward/rearward direction or the lateral direction.

**[0042]** With the above arrangement, the left and right foot supports 2a and 2b are allowed to reciprocate respectively along the lengths of the rails 63. The longitudinal direction of the rails 63 are inclined with the longitudinal center lines of the openings 11 a and 11 b respectively. Therefore, the left foot support 2a and the right foot support 2b are respectively moves along directions cross with the longitudinal direction of the openings 11a and 11b respectively and moves within the openings 11 a and 11 b respectively. That is, the trucks 61 cooperates with the wheels 62 and the rails 63 to define guides 4 which restrict the travel paths of the left foot support 2a and the right foot support 2b.

**[0043]** As above mentioned, the openings 11a and 11b respectively have its longitudinal center lines to make angles of 5 to 15 degrees with the forward/rearward direction of the housing 1. However, in view of that the user does not always orient one's foot in correct direction, each of the left foot support 2a and the right foot support 2b further is provided at its top surface with a positioning means 21 for notification of the correctly oriented position. The positioning means 21 may take the form of various configurations and include a marking recorded at the correctly oriented position as a simple one.

**[0044]** In addition, the left foot support 2a and the right foot support 2b have its top surfaces to have the top surface angles which are varied with respect to the top surface of the housing 1. Therefore, each of configurations in Fig. 3 may employ as the positioning means 21 for preventing displacement of the foot in a condition where the left foot support 2a and the right foot support are inclined.

**[0045]** Further, the positioning means 21 may be in the form of a recess 21a in the upper face of each of the left and right foot supports 2a and 2b, as shown in FIG. 3(a).

The positioning means 21 may be in the form of a lug 21 b on the upper face of each of the left and right foot supports 2a and 2b, as shown in Fig. 3 (b). The lug 21 b is preferred to be located to a position corresponding at least to one of the lengthwise ends of the foot. When it is located also corresponding to the arch of the foot, it is expected to give a massaging effect of stimulating the arch. The arrangements shown in FIGS. 3(a) and (b) do not fix the user's feet to the left and right foot supports 2a and 2b, respectively, it may occur that the foot is slipped out of the corresponding one of the left and right foot supports 2a and 2b when the support is tilted at a large angle.

**[0046]** In view of this, as shown in Fig. 3 (c), each of the left and right foot supports 2a and 2b may be provided with an anti-skid member 21 c formed from a material such as a rubber having a high coefficient of friction (or shaped to have minute surface irregularities) as the positioning means 21. The anti-skid member 21c may be adhered on or embedded in the upper surface of each of the left and right foot supports 2a and 2b. Further, the anti-skid member 21c may be shaped into a plate or into a configuration conforming to the contour of the bottom of the foot. Still further, the anti-skid member 26c may be combined with the recess 21a of FIG. 3(a) or the lug 21b of FIG. 3(b) for enhancing the positioning effect.

**[0047]** FIG. 3(d) illustrates the positioning means 21 in the form of belts 21d adapted to be wrapped around the foot instep and including front and rear ones. The foot inserted behind the belts is thus fixed to the foot support. The belts 21d may be provided with hook-and-loop fastener or buckle for adjustment depending upon the foot F size.

**[0048]** The individual features shown in FIG. 3 can be suitably combined. For example, the combination of the features shown in FIGS. 3(a), (c), and (d) can successfully prevent the foot slipping or skidding. When the device is utilized by the user with the shoe, the foot supports may be provided with a toe Clip or binding as is common to a pedal of bicycle for fixing the user's foot.

**[0049]** As shown in Fig. 4, the drive unit 3 comprises a motor 30, a router 33, a slide drive 31, and a swing drive 32. The motor 30 acts as a driving source, and is configured to generate a rotary force. The router 33 is configured to divide the rotary force into driving forces of two channels for driving the left foot support 2a and the right foot support 2b, and is configured to transmit the divided driving force to the left foot support 2a and the right foot support 2b. The slide drive 31 is configured to slide the left foot support 2a and the right foot support 2b along the upper face of the housing 1 by the driving forces that the router 33 divides into two channels. The swing drive 32 is configured to vary the top surface angle of the left foot support 2a and the right foot support 2b relative to the top surface of the housing 1. Both of the slide drive 31 and the swing drive 32 is provided to each of the left foot support 2a and the right foot support 2b.

**[0050]** Details of the drive unit 3 are now explained.

The router 33 is coupled to an output shaft 31a of the motor 31. The router 33 includes a worm 33a and a pair of worm wheels 33b. The worm 33a is defined as a first gear. The worm wheel 33b is defined as a second gear. A pair of the worm wheels 33b is meshed with the worm 33a. The worm 33a and the two worm wheels 33b are incorporated into a gear box which is not shown. This gear box is fixed to the base plate 1 a.

**[0051]** With this arrangement, the rotary force of the motor 30 is divided by way of the two worm wheels 33b into the individual driving forces which are respectively utilized to drive the left and right foot supports 2a and 2b. The router 33 thus composed of the worm 32a and the worm wheels 32b functions also to reduce the rotational speed of the motor 30.

**[0052]** A rotation shaft 33c penetrates through the worm wheel 33b. The rotation shaft 33c is coupled to the worm wheel 33b such that the rotation shaft 33c is rotated according to rotation of the rotation shaft 33c.

**[0053]** A reciprocator 33 includes a crank plate 36 and a crank rod 38. The crank plate 36 has one end coupled to the rotation shaft 33c. The crank rod 38 is coupled to the crank plate 36 through the crank journal 37. The crank journal 37 has one end which is fixed to the crank plate 36, and the other end held by the bearing 38a that one end of the crank rod 38 holds. That is, the crank rod 38 has one end which is rotatably coupled to the crank plate 36 and has the other end rotatably coupled to the truck 61 via a shaft body 38b.

**[0054]** Apparent from the above configuration, the crank rod 38 is configured to transmit rotary force into reciprocation of the truck 61. The crank rod 38 is provided for each worm wheel 33b. The left foot support 2a and the right foot support 2b respectively have the truck 61. Therefore, the crank rod 38 is configured to transmit rotary force into reciprocation of the left foot support 2a and the right foot support 2b.

**[0055]** As above mentioned, the truck 61 has the travel path which is restricted by the wheels 62 and the rail 63. Therefore, the truck 61 reciprocates along the longitudinal direction of the rail 63 according to the rotation of the worm wheel 33b. That is, the motor 30 generates the rotation which is transferred to the crank plate 36 through the worm 33a and the worm wheel 33b. The crank plate 36 is coupled to the crank rod 38 which reciprocates the truck 61 linearly along the rail 63. As a result, the truck 61 reciprocates the left foot support 2a and the right foot support 2b along the longitudinal direction of the rail 63 because the truck 61 s are respectively coupled to the left foot support 2a and the right foot support 2b.

**[0056]** In the present embodiment, the worm 33a and the two worm wheels 33b are responsible for routing the driving force into two channels respectively for driving the left and right foot supports 2a and 2b so that the drive unit 3 drives the left and right foot supports 2a and 2b in a manner linked to each other. The worm wheels 33b are engaged with the worm 33a at different portions spaced apart by 180 degrees. Therefore, the right foot support

2b comes to forward end of its movable range when the left foot support 2a comes to the rear end of its movable range. The rear end of the movable range of the left foot support 2a is same as the right end of the movable range of the left foot support 2a. The rear end of the movable range of the right foot support 2b is same as the right end of the movable range of the right foot support 2b. Therefore, the left foot support 2a and the right foot support 2bis configured to move toward a same lateral direction.

**[0057]** As apparent from the above, it is possible to give a desired phase difference of the movement between the left and right foot supports 2a and 2b by varying positions of engaging the worm 33a with the worm wheels 33b. When the device is used by the user at the standing posture with one's feet placed on the left and right foot supports 2a and 2b, the phase difference of 180 degrees is effective to minimize the shifting of the user's weight in the forward/rearward direction. Therefore, the exercise assisting device enables the user to exercise the lower leg muscles even by the user who suffers from balancing capability. Alternatively, when no phase difference is given, the device necessitates the shifting movement of the user's weight in the forward/rearward direction, thereby developing an exercise not only for the leg muscles but also for lower back muscles of the user maintaining the balancing capability.

**[0058]** The left foot support 2a and the right foot support 2b is configured to swing about an axle 74 which allows left foot support 2a and the right foot support 2b to have variable heights of its front ends and its rear ends. That is, the left foot support 2a and the right foot support 2b varies the heights of the toe and the heel on the left foot support 2a and the right foot support 2b, thereby allowing the ankle joint to plantarflex and dorsiflex.

**[0059]** In order to link the swinging movement of the left foot support 2a and the right foot support 2b about the axle 74 with the reciprocating movement thereof along the rail 63, the base plate 1 a is provided at a portion along the travel path of the left foot support 2a and the right foot support 2b with a guide surface 14 including an inclination 14a in Fig. 5. In this connection, each of the left foot support 2a and the right foot support 2b is provided on its bottom with a follower projection 25 which comes into engagement with the guide surface 14. The follower projection 25 has at its top with a roller 25 which come into rolling contact with the guide surface 14. That is, the axle 74 cooperates with the guide surface 14 and the follower projection 25 to construct a swing drive 32.

**[0060]** The follower projection 25, which is arranged to come into rolling contact with the guide surface 14, rides up and down the inclination 14a while each of the left and right foot supports 2a and 2b are driven by the motor 31 to reciprocates, thereby swinging the left foot support 2a and the right foot support 2b about the axles 24 to vary its tilt angle relative to the base plate 1a, and therefore enabling the plantarflexion and dorsiflexion at the ankle joint.

**[0061]** When using the device in the standing posture,

the user is first required to stand with one's feet placed respectively on the left and right foot supports 2a and 2b which are rest respective at their initial positions and then to start the drive unit 3. As shown in Fig. 6, the left foot support 2a and the right foot support 2b respectively has the longitudinal direction Dx oriented to a direction which make angle of, for example, 9 degrees with forward/rearward direction indicated by the arrow X. Consequently, the left foot support 2a and the right foot support 2b allows the user to stand naturally without twisting the user's leg.

**[0062]** At the initial positions, the left and right foot supports 2a and 2b are located at the same level along the forward/rearward direction. That is, the left foot support 2a is aligned with the right foot support 2b along the lateral direction of the device. Accordingly, when the user stands on the left and right foot supports 2a and 2b of the initial positions, a vertical line depending from the weight center of the user passes through a center between the left and right foot supports 2a and 2b.

**[0063]** As apparent from the above, the drive unit 3 can drive the left and right foot supports 2a and 2b to move in the forward/rearward direction and at the same time to move in the lateral direction in the linked manner to each other. The left and right foot supports 2a and 2b are driven to reciprocate linearly along the rails 63, respectively, so as to move in directions different from the lengthwise directions of the feet.

**[0064]** Also as discussed in the above, the foot plate 21 is driven to swing about the axle 74 as each of the left and right foot supports 2a and 2b reciprocates along the rail 63. While the foot plate 21 is moving, the follower projection 25 rides up and down the inclination 14a of the guide surface 14 to cause the dorsiflexion of the ankle joint when each of the left and right foot supports 2a and 2b comes to its forward end position, and the plantarflexion when it comes to its rearward end position. The axle 74 is positioned nearer to the heel within the length of the foot bottom. Each of the dorsiflexion and plantarflexion is realized at the tilt angle of about 10 degrees relative to a reference plane defined by the upper surface of the base plate 1a.

**[0065]** The dorsiflexion and the plantarflexion can be made respectively at the rearward end position and the forward end position of each of the left and right foot supports 2a and 2b in opposite relation to the above. Also, the tilt angle relative to the reference plane can be selected differently from the above mentioned angle. Such modified operation can be easily realized by an appropriate shaped guide surface 14.

**[0066]** In this embodiment, the worm 33a and the worm wheel 33b are used as transmission means of the rotation direction from the motor 30 defined as the driving source. However, combination of a pulley and a belt is also capable of employing as the transmission means. In addition, a universal joint is also capable of employing as the transmission means.

(Second embodiment)

**[0067]** The exercise assisting device in this embodiment has a slide drive 31 and a swing drive 32 which are respectively different from the slide drive 31 and the swing drive 32 shown in the first embodiment. In addition, the left foot support 2a and the right foot support 2b respectively have the representative point. This representative points are defined by points which do not shift when the angle that the top surface of the left foot support 2a and the top surface of the housing 1 make is varied, and are defined by points which do not shift when the angle that the top surface of the right foot support 2b and the top surface of the housing 1 make is varied. A plurality of the points is considered as the representative points. However, each of the points is capable of using as the representative point. That is, the exercise assisting device has the left foot support 2a and the right foot support 2b which slide along the top surface of the housing 1. In this condition, the exercise assisting device has the points which do not move while the angle between the left and right foot supports 2a, 2b and the top surface of the housing 1 varies. The points are determined as the representative points. These representative points are capable of designing outside the left foot support 2a and the right foot support 2b. With using the representative points defined by the above, the travel paths that the left foot support 2a and the right foot support 2b slide are described in an integrated fashion.

**[0068]** Fig. 7 shows the slide drive 31 and the swing drive 32. The transmission means for transmitting the driving force to the slide drive 31 and the swing drive 33 from the worm wheel 33b is omitted. However, the transmission means is constructed by well-known transmitting elements such as gear and belt.

**[0069]** The swing drive 32 is configured to vary the angle between the left foot support 2a and the top surface of the housing, and between the right foot support 2a and the top surface of the housing in order to vary the angle of the ankle joints. Therefore, the swing drive 32 is configured to vary the angle between the left foot support 2a and the top surface of the housing within a plane which is perpendicular to the extended line passing through the rotation center of the ankle joint. The swing drive 32 is configured to vary the angle between the right foot support 2b and the top surface of the housing within a plane which is perpendicular to the extended line passing through the rotation center of the ankle joint. Hereinafter, this plane is called as rotation plane. As mentioned below, it is not necessarily the case that the slide drive 31 slides the representative points of the left foot support 2a along a direction which is parallel to the rotation plane. It is not necessarily the case that the slide drive 31 slides the representative points of the right foot support 2a along a direction which is parallel to the rotation plane. However, in order to explain the exercise assisting device easily, the case that directions of the representative points of the left foot support 2a and the right foot support 2b re-

spectively slide parallel to the rotation planes is explained. The left foot support 2a and the right foot support 2b has representative points which slides along sliding directions which make angle of 5 to 15 degrees with forward/rearward direction of the housing 1. However, it is not necessarily the case that the sliding direction is aligned to the center lines of the longitudinal direction of the openings 11 a, 11 b.

**[0070]** The configuration in Fig. 7 is configured to vary angles of the left foot support 2a and the right foot support 2b. This configuration allows the toe to draw trajectory while the left foot support 2a and the right foot support 2b moves forward/rearward. This trajectory is a downward convex curve. The illustrated embodiment shows the left foot support 2a which is configured to allow the heel to be located below the toe in a condition where the left foot support 2a is positioned at the front end of the travel path, and shows the right foot support 2b which is configured to allow the heel to be located below the toe in a condition where the left foot support 2b is positioned at the front end of the travel path. On the contrary, the illustrated embodiment shows the left foot support 2a which is configured to allow the toe to be located below the heel in a condition where the left foot support 2a is positioned at the rear end of the travel path, and shows the right foot support 2b which is configured to allow the toe to be located below the heel in a condition where the right foot support 2b is positioned at the rear end of the travel path.

**[0071]** The slide drive 31 includes an eccentric rotor 34, a crank rod 35, and a crank pin 35a. The rotary force from the router 33 is transmitted to the eccentric rotor 34. The crank rod 35 has one end coupled to the eccentric rotor 34 via a crank pin 35a and has the other end which is rotatably fixed to a gear box 40 via the crank shaft 35b. The rack 41 in Fig. 7 has a longitudinal direction. The rack 41 restricts the travel path of the gear box 40 so that the travel path extends along the longitudinal direction of the rack 41. The rotation of the eccentric rotor 34 varies distance between one end of the crank rod 35 and rotation center 34a of the eccentric rotor 34. In this manner, the gear box 40 linearly moves along the longitudinal direction of the rack 41.

**[0072]** The gear box 40 bears two spur wheels 42 and 43. The spur wheel 42 has teeth whose number is smaller than the number of the teeth of the spur wheel 43. The spur wheel 42 is meshed with the rack 41. The rotation of the eccentric rotor 34 slides the gear box 40 relative to the rack 41. Consequently, the rack 41 which is meshed with the spur wheel 42 rotates the spur wheel 42 to generate the rotary force which is transferred to the spur wheel 43. While the eccentric rotor 34 rotates one revolution, the spur wheel 42 reciprocates on the rack 41. The reciprocation of the spur wheel 42 reciprocates the spur wheel 43 in a range of -30 to +30 degrees relative to the horizontal plane.

**[0073]** The spur wheel 43 is coupled to the left foot support 2a or the right foot support 2b.

**[0074]** Therefore, the spur wheel 43 vary the top surface angle of the left foot support 2a or the right foot support 2b according to the reciprocation of the spur wheel 43. In addition, the gear box 40 moves linearly along the rack 41, thereby the left foot support 2a or the right foot support 2b also moving linearly along the rack 41. In short, the rack 41 has the longitudinal direction which defines the sliding direction of the left foot support 2a or the right foot support 2b.

**[0075]** Apparent from the above, the gear box cooperates with the rack 41 to define a part of the slide drive 31. The rack 41 and the spur wheels 42 and 43 construct the swing drive 32. That is, in this embodiment, the slide drive 31 generates driving force which is transmitted to the swing drive 32 so that the driving force of the slide drive 31 and the driving force of the swing drive 32 are transmitted to the left foot support 2a or the right foot support 2b. It is noted that the illustrated embodiment shows the gear box 40, the spur wheel 43, the coupling shaft 43a, a rotor shaft 43b, and a swing plate 44. The gear box 40 is formed with an arc shaped guide hole 40a. The coupling shaft 43a is coupled to the spur wheel 43. The coupling shaft 43a is configured to pass through the guide hole 40a. The coupling shaft 43a and the rotor shaft 43b of the spur gear 43 are coupled to the swing plate 44. This swing plate 44 is coupled to the left foot support 2a or the right foot support 2b. That is, the rotor shaft 43b is defined as the axis about which the left foot plate and the right foot plate swings.

**[0076]** As apparent from the above, the rotor shaft 43b is located above the top surface of the corresponding one of the left and right foot supports 2a and 2b. In particular, the rotor shaft 43b is set at such a location where an extension line of the rotor shaft 43b extends through the ankle joint when the foot is placed at a position designated with the help of the above-mentioned positioning means 26. However, since there are differences among individual user's foot size, the positioning means 26 may be configured to be available irrespective of the foot size, such as the anti-skid member 26c or binding, or may be configured to be adjustable stepwise in match with the foot size. Further, it is preferred that the axis is aligned along a width direction of the foot such that the left foot support 2a and the right foot support 2b allows the ankle joints to vary the angle of the ankle joint according to the swing of the left foot support 2a and the right foot support 2b about the axis.

**[0077]** The rotor shaft 43b is spaced from the top surface of the corresponding one of the left and right foot supports 2a and 2b by a distance determined in consideration of an average foot size of the intended users. In addition, it is possible to detachably stack one of adjustor plates of different thickness on each of the left and right foot supports 2a and 2b, or even to provide an adjustor mechanism for varying the positions where the coupling shaft 43a and the rotor shaft 43b are coupled to the swing plate 44.

**[0078]** The operation derived from the structure of FIG.

7 is summarized in FIG. 8. In one operation of FIG. 8, each of the left and right foot supports 2a and 2b can be adjusted to have its upper surface inclined at a suitable angle. For example, one or both of the left and right foot supports 2a and 2b has its upper surface lying horizontally when the crank pin 35a comes in registration with either of the upper and lower position of the rotation center 34a of the eccentric rotor 34, as shown in FIG. 8.

**[0079]** Assuming that the right-hand side in FIG. 8 denotes the forward direction, when the crank pin 46a is located forwardly of the rotation center 34a of the eccentric rotor 34, the coupling shaft 43a takes a position forwardly of the rotor shaft 43b, as shown in FIG. 8(a), the corresponding one of the left and right foot supports 2a and 2b is inclined to have its front end located above its rear end, which means that the heel is lowered than the toe. While on the other hand, when the crank pin 35a is located behind the rotation center 34a of the eccentric rotor 45, the coupling shaft 43a takes a position behind the rotor shaft 43b, as shown in FIG. 8(c), the corresponding one of the left and right foot supports 2a and 2b is inclined to have its rear end located above its front end, which means that the toe is lowered than the heel.

**[0080]** Through the above operation, the foot position undergoes a sliding movement to stretch the leg muscle groups of the user in one hand, and the ankle joint undergoes variably angled movement to stimulate the lower leg muscle groups on the other hand. Thus, the movement simulating the walking is given to stimulate the muscle groups of the femoral region as well as the lower leg, which makes the device available for the walking exercise as in rehabilitation. Further, since the foot position sees only the sliding movement without requiring the user to lift the femoral portions, the device is also available to the user who is difficult to keep balancing due to knee joint pains or lowered femoral muscular strength. Further, the stretching of the lower leg muscle groups will relax muscle groups around the ankle joints to prevent the narrowing of the movable range thereof and to stretch the gastrocnemius muscles for promotion of venous return. The promotion of venous return makes it possible to increase the blood flow toward a heart and makes it possible to increase systemic blood flow.

**[0081]** In the above operation, since the toe is raised to a higher level than the heel as the corresponding one of the left and right foot supports 2a and 2b slides to its front end position within the movable range. The heel is raised to a higher level than the toe as the corresponding foot support slides to its rearward end of the movable range. Therefore, the operation can simulate a natural walking and therefore is available for walk training. However, the angle change about the rotor shaft 43b may be done in the direction opposite to that of the above operation. That is, different operation may be given in which the heel is raised to a higher level than the toe as the corresponding one of the left and right foot supports 2a and 2b slides to its front end position within the movable range. The toe is raised to a higher level than the heel

as the corresponding foot support slides to its rearward end of the movable range. In contrast to the former operation where the ankle joint undergoes less angle change, the latter operation enables the ankle joint to undergo the angle change over a wider range, effective for training of enlarging the movable range of the ankle joint. Especially, the ankle joint sees the dorsiflexion when the foot support comes to its rearward end position, thereby enhancing an effect of stretching the Achilles tendon.

**[0082]** As seen in the above illustrated embodiment, the rotor shaft 43b, which defines the rotation center about which the corresponding one of the left and right foot supports 2a and 2b swings, has its extension line passing through the ankle joint of the user, such that the ankle joint sees no substantial vertical movement during the corresponding one of the left and right foot supports 2a and 2b is swinging about the rotor shaft 43b. Thus, the ankle joint is relatively free from the load resulting from the vertical movement. In other words, the user sees only less load acting on the ankle joint as well as less shifting amount of the weight center, and therefore is easy to keep balancing. When adopting the above structure in which the extension line of the rotor shaft 43b passes through the ankle joint, it is required to locate the rotor shaft 43b above the corresponding one of the left and right foot supports 2a and 2b, which necessitates a large vertical space above the housing 1.

**[0083]** In order to reduce the vertical space above the housing 1, it is preferred to dispose the rotor shaft on the bottom side of each of the left and right foot supports 2a and 2b. For example, as shown in Fig. 9, it is preferred to arrange an axis Ax to be located below the foot bottom as well as to be located immediately below the ankle joints in a condition where the left foot support 2a and the right foot support 2b have upper surfaces which are parallel to the horizontal plane. It is possible to reduce the vertical space above the housing 1 by employing the swing drive 32 being configured to swing the axis Ax and the slide drive 31 being configured to slide the swing drive 32 to slide. By the axis Ax disposed as above, the ankle joint Ja is moved in the frontward/rearward direction while the angle of the left foot support 2a and the right foot support 2b is varied. However, the ankle joint Ja is little moved in the vertical direction while the angle of the left foot support 2a and the right foot support 2b is varied. Therefore, the position of the center of gravity Pg is little moved, thereby the user being able to keep balancing easily. That is, it is possible to obtain the exercise assisting device that the user suffering from lowered balancing capability is able to use easily. Further, there is no need for user to bend the knee joint Jn. Therefore, this exercise assisting device applies low load to the knee joint Jn, thereby being able to be used by the user having pain in knee.

**[0084]** In above configuration, the slide drive 31 and the swing drive 32 is driven by a single driving source which is the motor 30. However, it is possible to employ

the swing drive 32 which is driven by a driving source which is different from the driving source for driving the slide drive 31. To employ the driving sources for each of the slide drive 31 and the swing drive 32 increases freedom of the configuration of the slide drive 31. For example, it is preferred to employ the frame, not shown, which is configured to mount the left foot support 2a and the swing drive 32, and the frame, not shown, which is configured to mount the right foot support 2b and the swing drive 32. According to this configuration, each of the frames is slidably mounted on the guide rail. The frames are reciprocated by the driving force that the driving source generates. In a case where the motor is used as the driving source, it is possible to transmit the rotary forces into reciprocating movements of the left foot support 2a and the right foot support 2b by a crank mechanism which is interposed between the driving source and the left and right foot supports 2a, 2b.

**[0085]** With this configuration, the ankle joints are vertically moved according to the slide of the left foot support 2a and the right foot support 2b. However, the axis is located immediately below the ankle joint. Therefore, in a constrained condition where the axis is disposed below the left foot support 2a and the right foot support 2b, it is possible to minimize the distance between the ankle joint and the axis to reduce the amount of the displacement of the ankle joint in the vertical direction. Further, it is possible to combine the slide drive 31 and the swing drive 32 in order to employ simplified design. For example, it is preferred to slide the left foot support 2a and the right foot support 2b by the slide drive 31. According to this configuration, the left foot support 2a and the right foot support 2b are respectively provided with rotation shafts which act as the axes. A guide is provided for swinging the left foot support 2a and the right foot support 2b about the axes to vary angles. This guide is used by the swing drive 32. It is noted that the guide is constructed by the configuration same as the relation between a cam groove and a guide bar as mentioned in third embodiment.

**[0086]** The rotor shaft may be disposed at a position not immediately below the ankle joint but further away therefrom so as to increase the vertical displacement amount of the ankle joint, making the device effective for training balancing function of the user. That is, as shown in Fig. 11, the rotor shaft are arranged below the left foot support 2a and the right foot support 2b to have the axes Ax which are located below the foot bottoms as well as are located at a front portion from a portion immediately below the ankle joints Ja. On the contrary, as shown in Fig. 12, the rotor shaft are arranged below the left foot support 2a and the right foot support 2b to have the axes Ax which are located below the foot bottoms as well as are located at a rear portion from a portion immediately below the ankle joint Ja. With this configuration, it is possible to increase the displacement amount of the ankle joint in the vertical direction when the left foot support 2a and the right foot support 2b swings about the axes Ax.

**[0087]** The configurations in Fig. 11 and Fig. 12, the

rotor shafts have the axes which respectively located at front from the portion immediately below the ankle joint. The axis is swung to raise the heel being located higher than the toe when the left foot support 2a is located at the front end of the movable range. The axis is swung to raise the heel being located higher than the toe when the right foot support 2b is located at the front end of the movable range. On the contrary, the axis is swung to raise the toe being located higher than the heel when the left foot support 2a is located at the rear end of the movable range. The axis is swung to raise the toe being located higher than the heel when the right foot support 2b is located at the rear end of the movable range. When the left foot and the right foot are separately located in the forward/rearward direction by the above movement, the left foot and the right foot are separately located in the vertical direction. Therefore, the left ankle joint has height which is different from height of the right ankle so as to have vertical interval. This vertical interval causes the reflex for keeping balancing by the muscles of the knee joint, the hip joint, and the upper body, thereby the vertical interval stimulating the muscles. This stimulation trains the muscles around the knee joint, around the hip joint, and a lower back. Each of the slide directions of the left foot support and the right foot support makes an angle of 45 degrees with the forward/rearward direction. Therefore, the ankle joints are bent and stretched with the user's knee apart. Consequently, the muscles of an inside leg and an outside leg is stimulated.

**[0088]** The above instance illustrates that the rotor shaft 43b is oriented to have its axial direction perpendicular to the direction in which the representative point of the corresponding one of the left and right foot supports 2a and 2b makes the sliding movement. When it is required to cross these directions to make an angle other than the right angle, skew worm gears or bevel gears may be used instead of the spur gears 42 and 43.

**[0089]** It is equally possible to use a universal hook joint for driving connection between the slide drive 31 and the swing drive 32 at a desired angle. When using the universal hook joint, the left foot support 2a is integrated with the slide drive 31 and the swing drive 32 into one block. Similarly the right foot support 2b is integrated with the slide drive 31 and the swing drive 32 into one block. Then, the two blocks are individually made adjustable to determine the angle at which the direction of the sliding movement of the representative point of each of the left and right foot supports 2a and 2b is inclined relative to the forward/rearward direction of the housing 1.

**[0090]** For instance, each block is coupled at its rear end to the housing 1 by means of a pivot pin so as to be capable of swinging within the horizontal plane, and is provided with a latch pin which is selectively engaged into one of holes spaced from the rotation center of the block by a constant distance. Thus, it is possible to select one from a plurality of the sliding movement directions along each of which the corresponding one of the left and right foot supports 2a and 2b moves. In this instance,

each of the left and right foot supports 2a and 2b undergoes the sliding movement linearly along the travel path. Thus, it is possible to adjust the angle of the travel path relative to the forward/rearward direction. In this sense, each block is cooperative with the pivot pin, the latch pin, and the holes to realize a moving direction determination mechanism.

**[0091]** Since the slide drive 31 and the swing drive 32 are coupled to each other by means of the universal hook joint, each of the left and right foot supports 2a and 2b can have its sliding movement direction which is adjustable over a wide range, while the maintaining an angle of 5° to 15° at which the swinging plane perpendicular to the rotor shaft 43b is inclined relative to the forward/rearward direction of the housing 1. For instance, the sliding movement direction of each of the left and right foot supports 2a and 2b can have its sliding movement direction inclined relative to the forward/rearward direction of the housing 1 at an angle of 5° to 45° (counter-clockwise angle for the left foot support 2a, and clockwise angle for the right foot support 2b).

**[0092]** The sliding movement direction which is oriented at an angle of 5 to 15 degree with respect to the forward/rearward direction is aligned with a direction of bending and stretching the knee joint or the ankle joint of the user in the standing posture with relaxing the leg muscles. Therefore, it is possible to expand and contract the leg muscle while the load applied to the knee joint and the ankle joint is reduced. In addition, it is possible to stimulate the adducent muscles and abducent muscles by adjusting the angle between the forward/rearward direction and the sliding movement direction of 45 degrees.

**[0093]** in addition, when the left foot support 2a has the representative point being located at the front end of the movable range, the right foot support 2b has the representative point being located at the rear end of the movable range. On the contrary, when the right foot support 2b has the representative point being located at the front end of the movable range, the left foot support 2a has the representative point being located at the rear end of the movable range. That is, the left foot support 2a and the right foot support 2b is designed to be driven to move in opposite phase relation to each other. This configuration makes it possible to reduce the movement of the user's center of the gravity in the forward/rearward direction. Therefore, the user whose balance function is atrophied is also use the exercise assisting device.

**[0094]** Although the above embodiment illustrates that the slide drive 31 and swing drive 32 are arranged to operate at the same cycle, they may be arranged to operate at differing cycles. When so arranged, the device gives an irregular movement different from the normal walking for enabling a training of sophisticate movement. In addition, the left foot support 2a and the right foot support 2b is moved in a linked manner such that the positions of the left foot support 2a and the right foot support 2b varies at the same time. However, it is also possible to drive only one of the left foot support 2a and the right

foot support 2b to move as above. In this case, the user having injured one leg is able to use this exercise assisting device by only driving the either the left foot support 2a or the right foot support 2b in order to exercise the other uninjured leg.

**[0095]** Furthermore, this exercise assisting device is designed to be used in the standing posture. However, the user with less balancing ability may use this exercise assisting device while sitting a chair or a wheeled chair. In addition, the user with less balancing ability may also use this exercise assisting device while the user's upper body is lifted by a lifting sling. When the user uses the exercise assisting device while the user's upper body is supported, the user's own weight is hard to be applied as the load, However, the user is able to use the exercise assisting device with the low load. Therefore, exercise assisting device is capable of being adapted for the user with various body conditions. Further, in a case where the user who sits on the chair uses the exercise assisting device, variation of height of the chair enables the user to adjust degrees of the load. Therefore, it is possible to obtain the exercise assisting device being configured to adjust degree of the load according to the user's physical strength. Further, in a case where the user who is lifted by the lifting sling use this exercise assisting device, it is preferred that the lifting sling is configured to lift the user's body only when the user lose the user's balance to come near to fall. With this configuration, it is possible to obtain the exercise assisting device which is suitable for the user who loses balance due to atrophy of the balance function or for the user who loses the strength of the muscles.

**[0096]** Furthermore, in a case where the user uses the exercise assisting device for stimulating the leg muscles, it is possible to dispose the housing 1 to have the left foot support 2a and the right foot support 2b which is driven to move in the vertical direction as well as in the lateral direction. Consequently, the user is able to use the exercise assisting device with supine body position. In this case, the user's weight causes no load. However, hospital patients who lie in hospital beds are also able to use the exercise assisting device. Therefore, the exercise assisting device with the above disposition makes it possible for the hospital patients who lie in the hospital beds to prevent the loss of the leg muscle strength and blood stasis of the leg. Furthermore, the exercise assisting device with the above disposition makes it possible for the hospital patients who lie in the hospital beds to prevent bedsores by varying the position of the user's back.

(Embodiment 3)

**[0097]** The present embodiment is basically identical to the first embodiment except for the configuration of the slide drive 31 and the swing drive 32. As shown in FIG. 13, the swing drive 32 includes a pair of side plates 22 depending from the opposite lateral sides of each of the left and right foot supports 2a and 2b. Each of the

side plates 22 is formed with a cam groove 23 which extends through the side plate 22 in lateral direction. Two guide bars 24 are fixed on the housing 1 and extend through cam grooves 23. The slide drive 31 has the same configuration as in the second embodiment to have the eccentric rotor 34 receiving the rotary force from the router 33, and the crank rod 35 which has its one end coupled to the eccentric rotor 46 and has its other end coupled to the corresponding one of the left and right foot supports 2a and 2b by way of the crank journal 35b.

**[0098]** The cam groove 23 has an inverted V-shape with its opposite ends lowered than its center. The two guide bars 24 are provided to bear the load acting on the corresponding one of the left and right foot supports 2a and 2b.

**[0099]** Since the cam groove 28 has its center higher than its opposite ends, while each of the left and right foot supports 2a and 2b is driven by the slide drive 31 to make the sliding movement, the upper surface of each foot support is varying its surface angle in such a manner that the toe is lowered than the heel when each foot support comes to its forward end position, and the heel is lowered than the toe when each foot support comes to its rearward end position, as shown in FIG. 14.

**[0100]** As the contour of the cam groove 23 determines the manner of varying the top surface angle of the left and right foot supports 2a and 2b, it is easy to give a suitable relation between the position along the sliding movement path and the vertical displacement for each of the left and right foot supports 2a and 2b. Further, the above configuration enables to swing each foot support without requiring to drive the foot support about a dedicated axis, enhancing flexibility of designing various patterns of varying the angle of the ankle joint.

**[0101]** With the use of the side plates 22 with V-shaped cam groove 23 instead of the inverted V-shaped cam groove 23, the toe is raised higher than the heel when the corresponding one of the left and right foot support 2a and 2b comes to the forward end position of its sliding movement range, and the heel is raised higher than the toe when the toe when it comes to the rearward end position of the sliding movement range. Although Fig. 13 shows the configuration by which the angle of the ankle joint varies in a pattern different from the walking with varying foot position along the forward/rearward direction, the cam groove 28 may be suitably shaped to bring about the same pattern of varying the angle of the ankle joint as seen in the walking.

**[0102]** The illustrated embodiment has the cam grooves 23 each in the form of slot through which the guide bars 24 extend. However, it is also possible to employ only a cam face, without the cam groove 23 in the side plate 22. With this configuration, it is possible to reduce the vertical dimension of the housing for realizing a low-profile structure of the housing 1.

**[0103]** Since the present embodiment is identical to the second embodiment except for the structure of the second driver 32, no further explanation is deemed nec-

essary for the identical structures.

(Fourth embodiment)

**[0104]** In above mentioned embodiment, the slide drive is configured to slide the left foot support 2a and the right foot support 2b relative to the housing 1. However, it is possible to employ the left foot support 2a and the right foot support which are not driven to slide by the slide drive 32 but driven to swing by the swing drive. In short, the left foot support 2a and the right foot support 2b are configured to be driven to swing relative to the housing 1, and are not configured to driven to slide relative to the housing 1.

**[0105]** Fig. 15 shows a schematic configuration of the drive unit 3. The motor 30 which acts as the driving source has the output shaft 30a which is coupled to a conical gear 33. The conical gear 33 is meshed with two pinions 33d. That is, the conical gear 33c cooperates with the pinions 33d to constitute the router 33. The pinions 33d of the router 33 are respectively coupled to a rotor shafts 43c which act as the axles of the left foot support 2a and the right foot support 2b.

**[0106]** The conical gear 33c is meshed with the pinions 33d at meshing points. The meshing points are set to have the phase difference of 180 degrees. Therefore, the inclination angle of the left foot support 2a with respect to the right foot support 2b has the phase difference of 180 degrees. That is, when the front end of the left foot support is located at a lowest position of the movable range, the right foot support is located at a highest position of the movable range. On the contrary, the front end of the left foot support 2a is located at a highest position of the movable range, the right foot support is located at a lowest position of the movable range. The movement direction of the left foot support 2a upward from beneath or downward from above is switched by rotation direction of the motor 30. In short, the exercise assisting device further comprises a sensor and a controller which are not shown. The sensor is configured to sense at least one of rotation angle of the motor 30 or the position of the left foot support 2a and the right foot support 2b. The controller controls the rotation direction of the motor so as to vary the angle of the left foot support 2a and the right foot support 2b within a suitable angle range.

**[0107]** Both of the rotor shafts 43c is disposed to make angle of 10 degree with the lateral direction of the user. Thus, it is preferred that the positioning means 21 in Fig. 3 is arranged on the left foot support 2a and the right foot support 2b to allow the user's foot to orient a direction perpendicular the rotor shaft 32c. With this configuration, the user's left foot has the toe being located at left side from the heel of the left foot. The user's right foot has the toe being located at right side from the heel of the right foot. In other words, the user is able to stand to have angle of 20 degrees between the one's legs by putting the user's feet on the positioning means 21, thereby being able to have the standing posture naturally. Con-

sequently, there is no possibility of twisting the user's ankle joint and the user's knee joint. It is more preferred that the left foot support 2a is spaced from the right foot support by a lateral distance which has almost same distance between the hip joints. Accordingly, it is possible

[0108] By the way, in the illustrated embodiment, each of the rotor shafts 43 which define the axis Ax is located at front side of a position immediately below the ankle joint. Therefore, as shown in Fig. 12, the ankle joints are moved to vary the vertical position according to the swing of the ankle joint. Because the left foot support 2a and the right foot support 2b are not configured to slide, the positions of the left and the right foot within the upper surface of the housing 1 is not varied. However, the swing of the ankle joint causes variation of the height of the ankle joints. As a result, same as the first embodiment, it is possible to stimulate the muscles around the knee joint, the hip joint, and the lower back. The exercise assisting device in this embodiment is same as the first embodiment excepting for feature that the slide drive 31 is not employed.

(Fifth embodiment 5)

[0109] The exercise assisting device in the fourth embodiment has the rotor shafts 43c which are disposed at the front side from the position immediately below the ankle joint, thereby the ankle joint is moved largely along the vertical direction. On the contrary, as shown in Fig. 16, it is possible to employ the configuration which is configured to displace the rotor shaft 43d along the vertical direction. With this configuration, it is possible to further increase the variation amount of the ankle joint in the vertical direction.

[0110] In the illustrated embodiment, each of the left foot support 2a and the right foot support 2b has the rotor shaft 43d which is fixed at the front side from a position immediately below the ankle joint. Each of the left foot support 2a and the right foot support 2b has its rear end fixed to the guide shaft 46. Both ends of the rotor shaft 43d extends to project on either side of each of the left foot support 2a and the right foot support 2b, thereby the rotor shaft 43d extending through the guide slit 45a which is provided with the bearing 45. Therefore, the guide shaft 46 has both ends which project on either side of each of the left foot support 2a and the right foot support 2b, and is held by the slide slits 47a at holders 47. The slide slit 47 is formed to have a curved shape such that the guide shaft 46 is capable of moving upward and downward. That is, the slide slit 47 is curved to have a mid portion and the both end in the vertical direction. The distance between the bearing 45 and the mid portion of the slide slit 47 is larger than the distance between the bearing 45 and the both end of the slide slit 47.

[0111] In order to move the guide shaft 46 in a vertical direction along the slide slit 47, the crank rods 48 respectively have one end coupled to the left foot support 2a

and the right foot support 2b, and have the other end coupled to an eccentric rotor 49 formed to have disk shape to be rotate in either of its opposite direction by the motor which is not shown. Attachment position of the eccentric rotor 49 to the crank rod 48 is apart from the center of the eccentric rotor 49. When the eccentric rotor is rotated in either opposite direction, the position of one end of the crank rod 46 in the slide slit 47 is varied.

[0112] However, there is a necessity to apply force of raising the guide shaft 46 when the one end of the crank rod 46 is raised from the lowest position to the highest position according to the rotation of the eccentric rotor 49. Therefore, in the illustrated embodiment, the left foot support 2a has lower surface coming into contact with eccentric cam 50. The right foot support 2b has lower surface coming into contact with eccentric cam 50. These eccentric cams 50 are rotated by the rotation of the eccentric rotor 49. The eccentric rotors 49 are coupled to the eccentric cam 50 via a connection rod which is not shown. The left foot support 2a is raised by the eccentric cam 50 when one end, coupled to the eccentric rotor 49, of the crank rod 48 is located at the top end. The right foot support 2b is raised by the eccentric cam 50 when one end, coupled to the eccentric rotor 49, of the crank rod 48 is located at the top end. That is, the eccentric rotor 49 are coupled to the eccentric cam 50 via the connection rod. The eccentric rotor 49 is rotated with the eccentric cam 50 in a linked manner.

[0113] In this arrangement, the linked manner is configured to have the rotor shaft 43d being located at the lower end of the movable range when the heel is located lower than the toe, and is configured to have the rotor shaft 43d being located at the upper end of the movable range when the heel is located higher than the toe. Therefore, compared with a case where each of the left foot support 2a and the right foot support 2b is simply swung about the rotor shaft 43d, the configuration makes it possible to move the ankle joint of the vertical direction largely. The large vertical movement of the ankle joint applies large stimulations to the muscles of the knee joint, the hip joint, and the upper body. Therefore, it is possible to increase the training effect. The other configurations and movements are same as the first embodiment.

[0114] In each of the above embodiments, the exercise assisting device comprises the left foot support 2a and the right foot support 2b each of which is swung about the rotor shaft 43, the axle, as a center. However, the axle receives a large load in a case where only the axle supports the user's weight. Thus, there is a necessarily to employ axles and bearings which have large strength. Therefore, it is preferred to employ an auxiliary spring 51 which is disposed between the left foot support 2a and the housing 1 to receive a part of the user's weight. Similarly, it is preferred to employ an auxiliary spring 51 which is disposed between the right foot support 2b and the housing 1 to receive a part of the user's weight. These auxiliary springs 51 are configured to distribute the load which is applied to the left foot support 2a and the right

foot support 2b.

**[0115]** In the illustrated embodiment, the auxiliary spring 51 is disposed at the front of each of the left foot support 2a and the right foot support 2b. The auxiliary spring 51 is utilized for compression, and is attached in a more compressed condition than a natural length of the auxiliary spring 51. In addition, the auxiliary springs 51 are configured to generate spring biases which keep the upper surfaces of the left foot support 2a and the right foot support 2b horizontally. Therefore, the axles receive the upward force constantly. Therefore, the spring bias reduces the load which is caused by the user's weight and is applied to the left foot support 2a and the right foot support 2b. Therefore, the spring bias reduces the load applied to the axle. That is, the auxiliary spring 51 makes it possible to employ axles and bearings which have low strength.

**[0116]** In Fig. 17, the exercise assisting device comprises a rotor 52. The rotor 52 is configured to rotate in either of its rotation direction upon receiving the rotary forces of the motor defined as the driving forces in order to swing the left foot support 2a and the right foot support 2b. The left foot support 2a and the right foot support 2b are respectively formed with guide slits 53 which extend along the longitudinal direction of the left foot support 2a and the right foot support 2b. The guide slit 53 is configured to receive a slide pin 52 being projected to the rotor 52. The rotor 52 is configured to be rotated around a center axis extending along the width direction of the foot. The slide pin 52a is projected along the center axis of the rotor 52.

**[0117]** The rotor 52 is rotated in a condition where the user's weight is located at a position upside of the rotation center of the rotor 52. The right side of Fig. 17 (a) shows the front side of the exercise assisting device. As shown in Fig. 17, when the slide pin 52a is moved to be located at a rear from the center axis of the rotor 52, the user's weight causes the rotary force which rotates the left foot support 2a around the slide pin 52a and which directs the user's toe downwardly. Similarly, when the slide pin 52a is moved to be located at a rear from the center axis of the rotor 52, the user's weight causes the rotary force which rotates the right foot support 2b around the slide pin 52a and which direct the user's toe downwardly. As shown in Fig. 17 (b), when the slide pin 52 is moved to be located at the front from the center axis of the rotor 52, the user's weight causes the rotary force which rotates the left foot support 2a around the slide pin 52a and which directs the user's heel downwardly. Similarly, when the slide pin 52 is moved to be located at the front from the center axis of the rotor 52, the user's weight causes the rotary force which rotates the right foot support 2a around the slide pin 52a and which directs the user's heel downwardly.

**[0118]** In this case, the auxiliary spring 51 is attached to the front end and the rear end of the left foot support 2a. Therefore, the left foot support 2a is allowed to swing about the slide pin 52a to vary an angle arbitrarily. The

auxiliary spring 51 is attached to the front end and the rear end of the right foot support 2b. Therefore, the right foot support 2b is allowed to swing about the slide pin 52a to vary an angle arbitrarily. However, in this configuration, the swing angle of the left foot support 2a and the right foot support 2b is varied according to the user's weight and the standing position. Therefore, it is preferred to employ a stopper which is configured to prohibit the inclination of the left and right foot supports 2a, 2b to have an inclination angle larger than a predetermined angle.

**[0119]** In the above mentioned embodiment, the left foot support 2a and the right foot support 2b respectively have its upper surface which is planate. However, it is not necessarily the case to employ the left and right foot support 2a and 2b which have planate upper surface.

**[0120]** For example, it is possible to employ the left foot support 2a and the right foot support 2b respectively formed to have cylindrical column shape shown in Fig. 18. According to this configuration, each of the left foot support 2a and the right foot support 2b has its swing center which is aligned to the axle for varying the top surface angle of each of the left foot support 2a and the right foot support 2b. With this configuration, contact positions of the foot bottom and the left foot support 2a is varied according to the rotation of the left foot support 2a while the representative points of the left foot support 2a slides. Therefore, the upper surface angle of the left foot support 2a is varied. Similarly, contact positions of the foot bottom and the right foot support 2a is varied according to the rotation of the right foot support 2a while the representative points of the right foot support 2a slides. Therefore, the upper surface angle of the right foot support 2a is varied. At this time, the load applied to a portion of the foot bottom is varied. Therefore, the angle of the knee joints is varied. As a result, same effect in the first embodiment is expected.

**[0121]** In addition, according to the variation of the position to which the load is applied, reflex points in the foot bottoms are stimulated. Furthermore, not whole of the foot bottom but a part of the foot bottom receives the user's weight, the user is required to put some toe muscle in order to keep balance. As a result, muscles relates to the toe muscles is strengthened, thereby force of a kick being increased. In addition, comparing with the above embodiments, because difficulty of keeping balance is increased, the muscles such as the lower back and the nervus for keeping balance are trained.

**[0122]** It is possible to employ the left and right foot supports 2a and 2b respectively being formed to have a sphere shape shown in Fig. 19 instead of the cylindrical column shape. By operating the sphere-shaped left and right foot supports 2a and 2b similar to the cylindrical column shape of the left and right foot supports 2a and 2b, contact area between the foot bottom and the each of the left and right foot support 2a and 2b is decreased. Therefore, it is possible to train the advanced balance training.

**[0123]** It is noted that the single motor 30 is employed in order to slide the left foot support 2a and the right foot support 2b as well as to vary the upper surface angle of the left foot support 2a and the right foot support 2b at the same time in the above embodiments. However, it is possible to employ two motor instead of the router 33 in order to individually move the left foot support 2a and the right foot support 2b. It is possible to employ the individual motor for the slide drive 31 and the swing drive 32. In a case where the configurations are employed, it is required to employ a controller for operating the both of the motors in a linked manner. Further, the motor is not limited to the rotation motor. A linear motor is also capable of employing as the motor.

## Claims

### 1. An exercise assisting device comprising:

a left foot support (2a) and a right foot support (2b) respectively configured to bear a user's left foot and right foot;  
 a drive unit (3) configured to displace at least one of said left and right foot supports (2a, 2b);  
 and  
 a frame mounting said left and right foot supports (2a, 2b) and said drive unit (3) ,

wherein

each of said left and right foot supports (2a, 2b) is provided with positioning means prompting a placement of the user's foot on a prescribed position,  
 each of said left and right foot supports (2a, 2b) is arranged to prescribe a foot position on which the foot is placed on,  
 said drive unit (3) includes a swing drive configured to vary an angle of a top surface angle of at least one of said left and right foot supports (2a, 2b) relative to said frame for varying an ankle joint angle,  
 wherein  
 the left foot support and the right foot support (2a, 2b) has its bottom integrally formed with a pair of bearings,  
 an axle (74) penetrates through legs of the bearings to extend in a width direction of the left foot support (2a),  
 an axle (74) penetrates through legs of the bearings to extend in a width direction of the right foot support (2b),  
 the left foot support (2a) and the right foot support (2b) are allowed to swing about the axle (74) in such a manner that the left foot support and the right foot support move up and down at its lengthwise forward and rearward ends.

### 2. The exercise assisting device as set forth in claim 1, wherein

said exercise assisting device further comprises a housing (1) which comprises a base plate (1a) and an upper plate (1b) which is disposed above said base plate (1a),

said upper plate (1b) being formed with two openings (11a, 11b) extending in a thickness direction of the upper plate (1b) to expose the left foot support (2a) and said right foot support (2b) , respectively,  
 each of said openings (1 1a, 11b) has an open area greater than a top surface area of each of the left and right foot supports (2a, 2b), so that the left and right foot supports (2a, 2b) are movable respectively within the openings (11a, 11b).

### 3. The exercise assisting device as set forth in claim 2, wherein

a longitudinal direction of each of the openings (11a, 11b) is inclined at an angle relative to a forward/rearward direction of the base plate (1a), and  
 said openings (11a, 11b) have lengthwise directions respectively aligned with the longitudinal directions of the left and right foot supports (2a, 2b).

### 4. The exercise assisting device as set forth in claim 2 or 3, wherein

said base plate (1a) has an upper end being formed with two fixed rails (63) for each of the left and right foot support (2a, 2b),  
 said left and right foot support (2a, 2b) being allowed to reciprocate respectively along lengths of the rails (63),  
 each said rails extending in direction different from the lengthwise direction of the opening (11a, 11 b) in the housing (1),  
 said openings (11a, 11b) having their individual longitudinal center lines crossed with each other so as to be spaced by a larger distance at the forward ends than at the rearward ends.

### 5. The exercise assisting device as set forth in claim 4, wherein

said rails (63) have individual longitudinal directions crossed with each other so as to be spaced by a larger distance at the frontward ends than at the rearward ends.

### 6. The exercise assisting device as set forth in claim 4 or 5, wherein

said rails are inclined in relation to a forward/rearward direction of said housing (1) at a large angle than the openings (11a, 11b).

### 7. The exercise assisting device as set forth in claim 5 or 6, wherein

the longitudinal directions of the rails are inclined with the longitudinal center lines of the openings (11a, 11b), respectively.

8. The exercise assisting device as set forth in one of the preceding claims, wherein a plane perpendicular to the axle (74) is defined as a swinging plane, said swinging plane is inclined at an angle of 5 degrees to 15 degrees relative to the forward/rearward direction of the housing (1).

10

15

20

25

30

35

40

45

50

55

Fig. 1

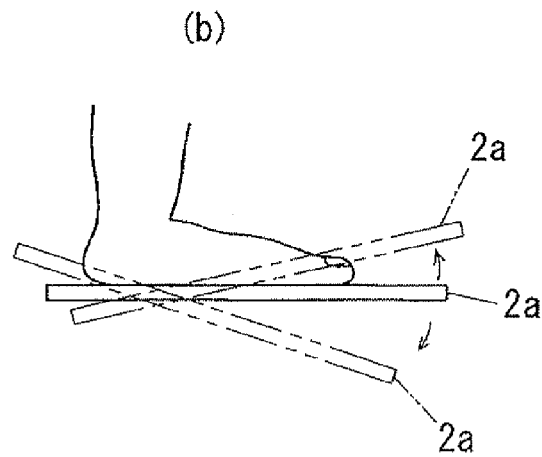
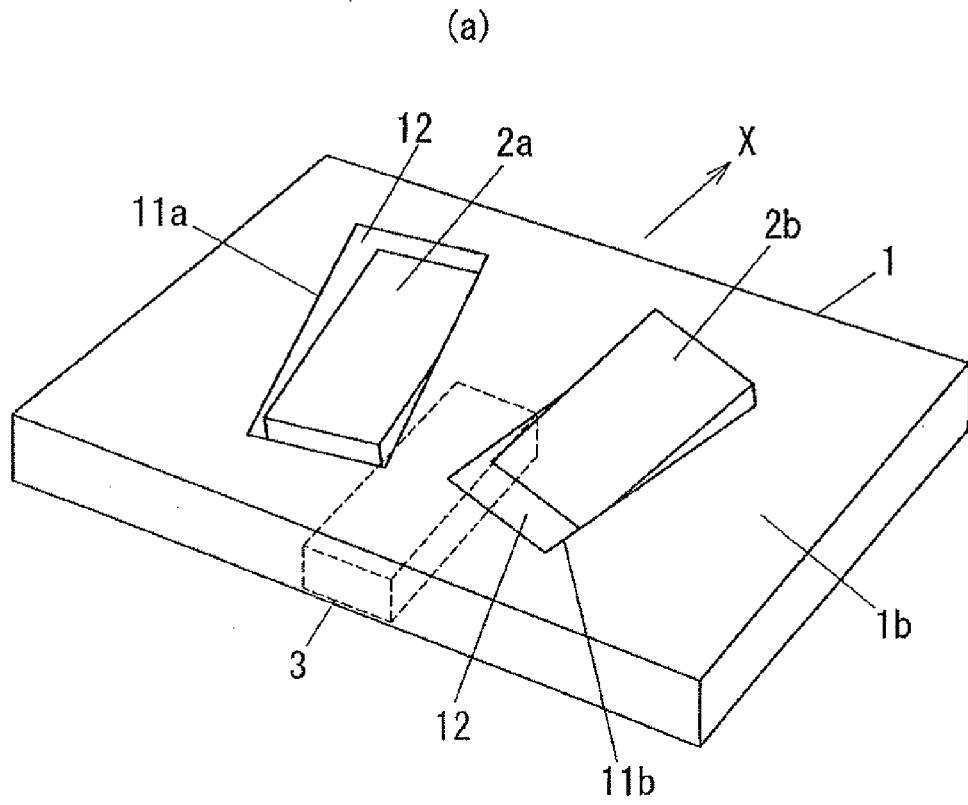

Fig 2

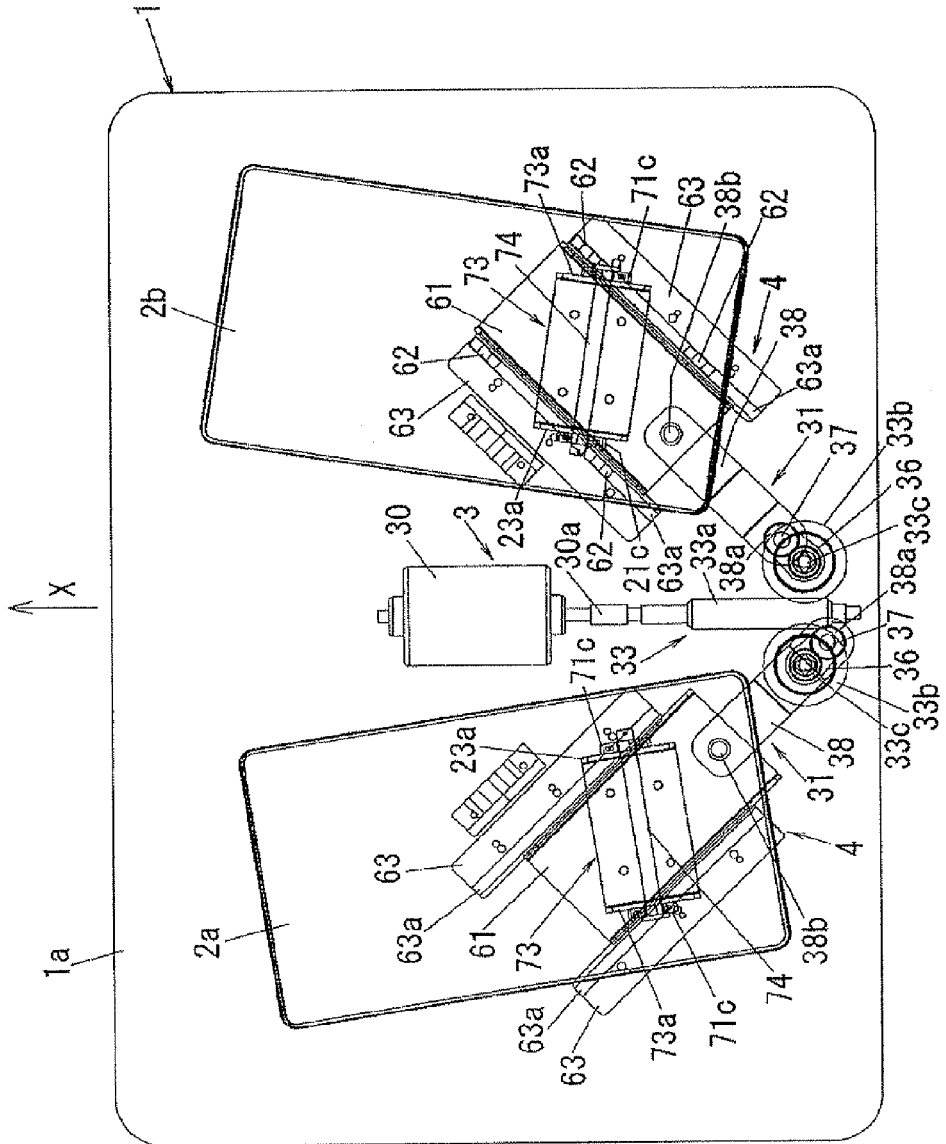

Fig. 3

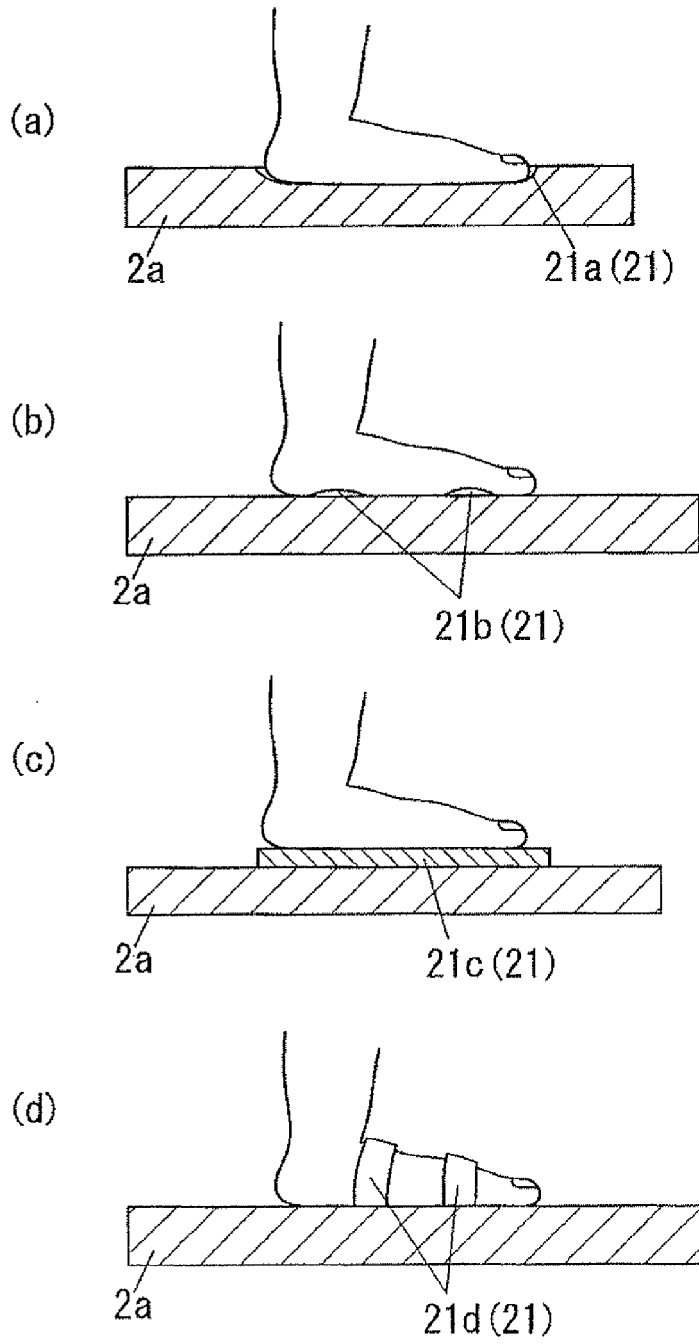

Fig. 4

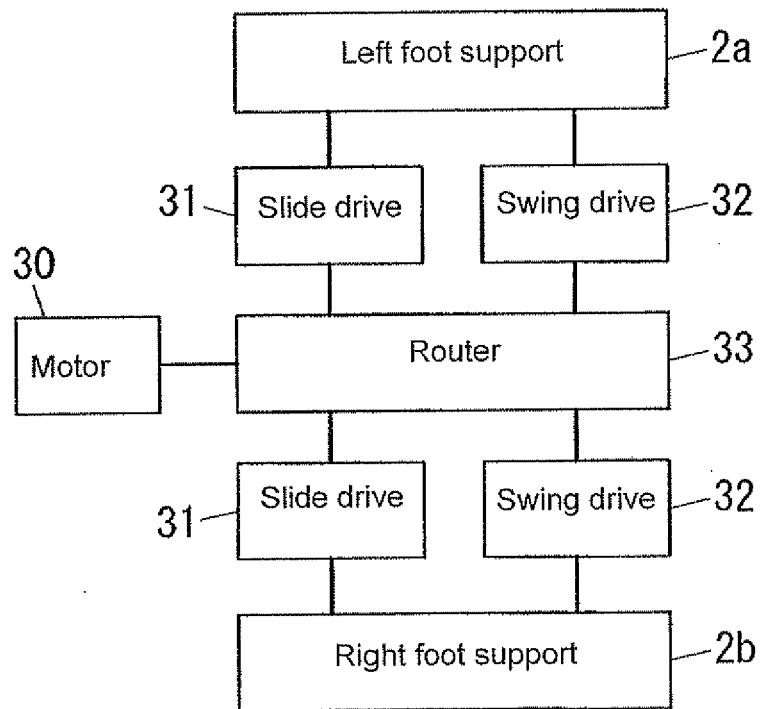

Fig. 5

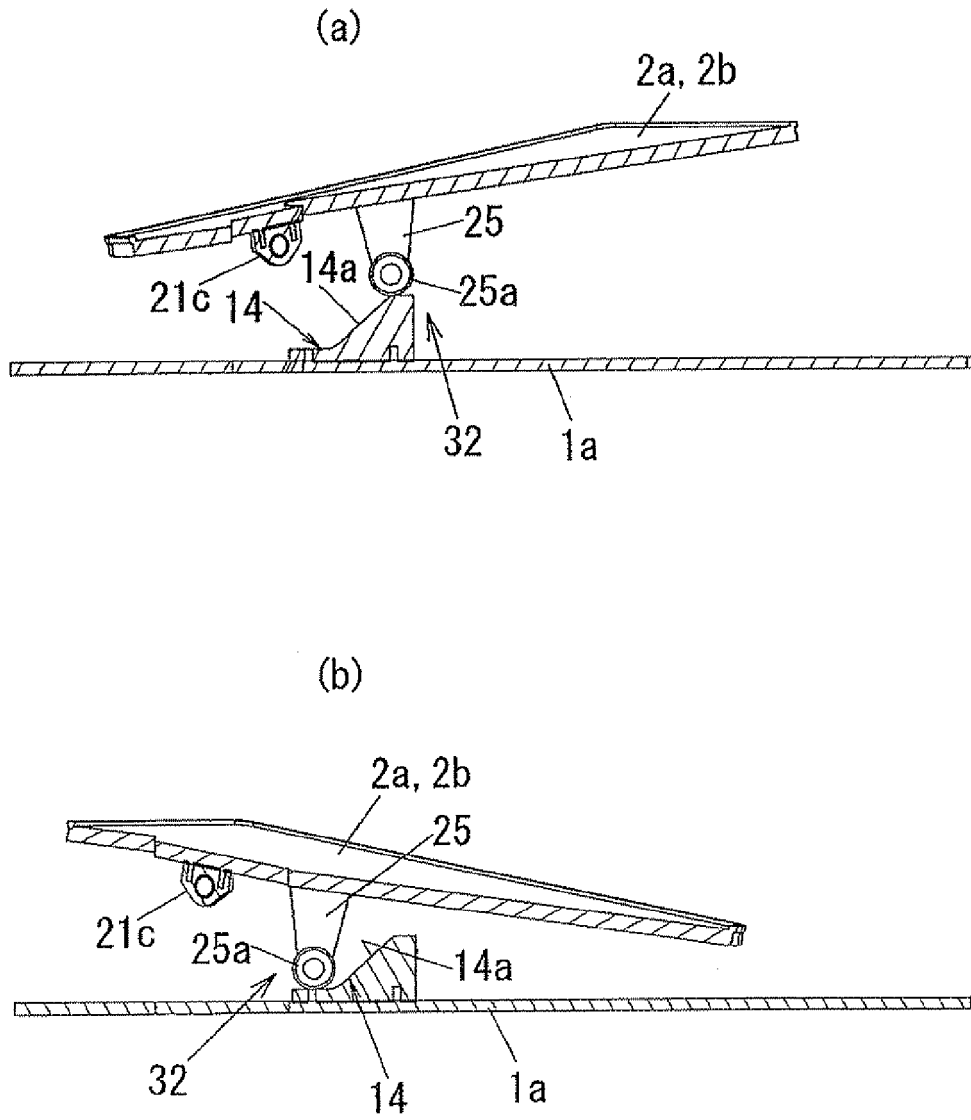

Fig. 6

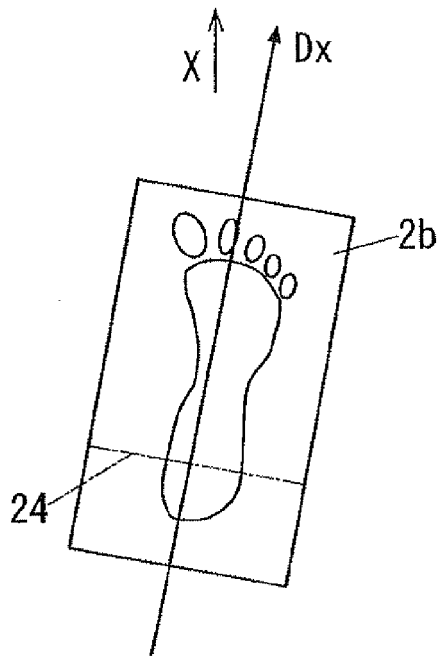

Fig. 7

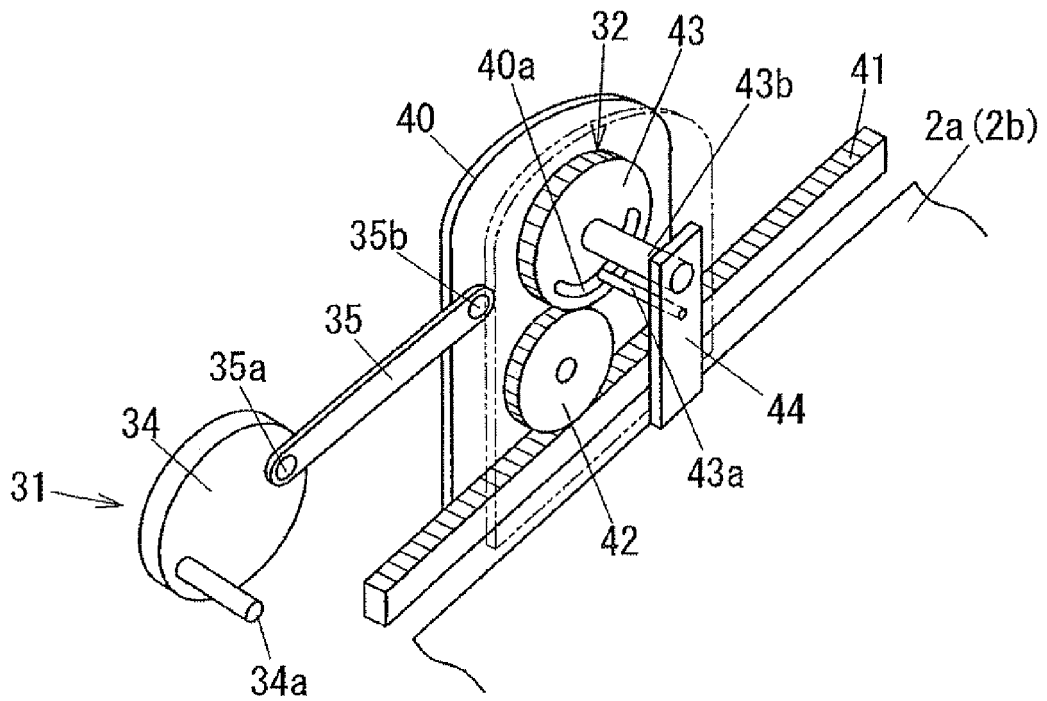

Fig. 8

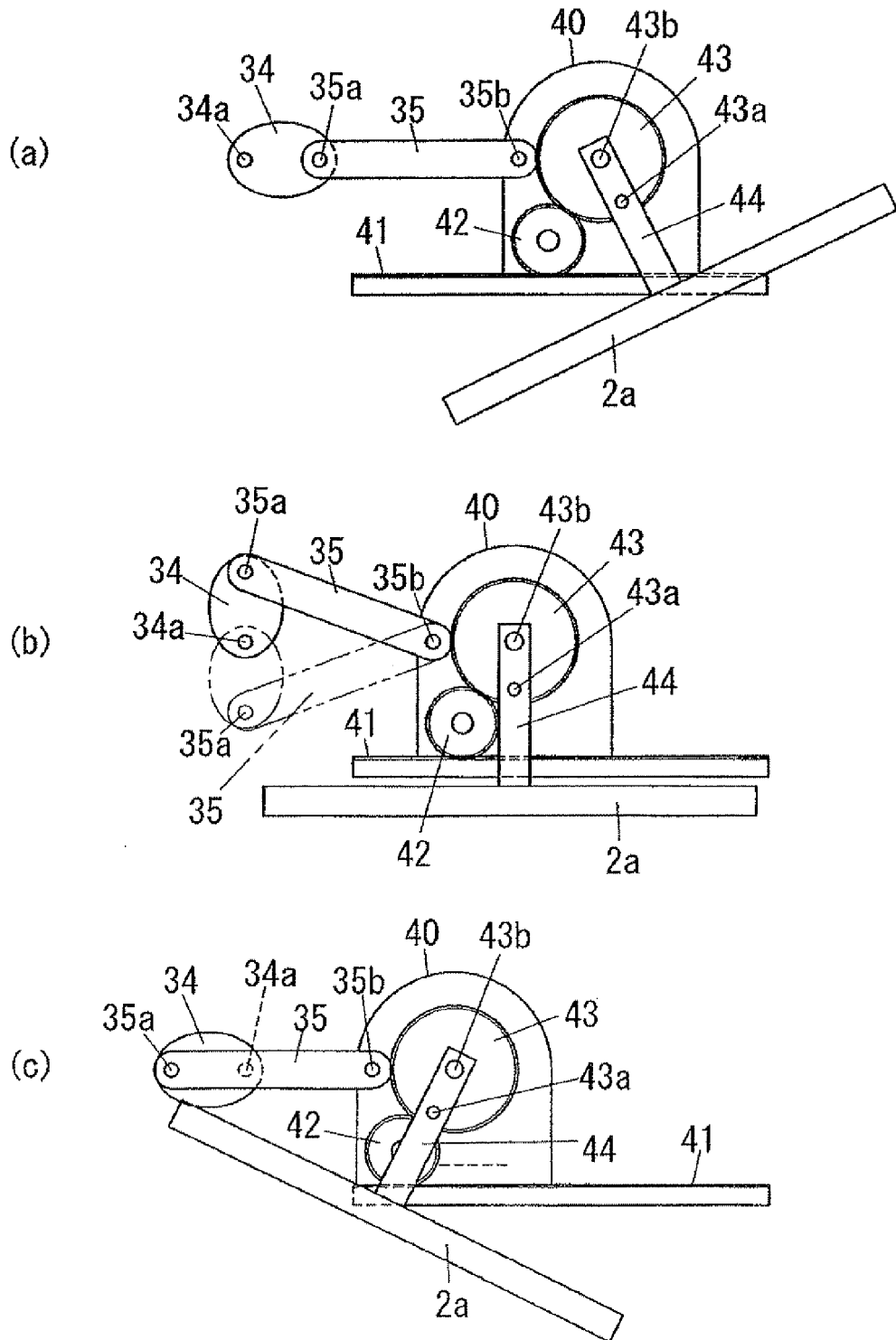

Fig. 9

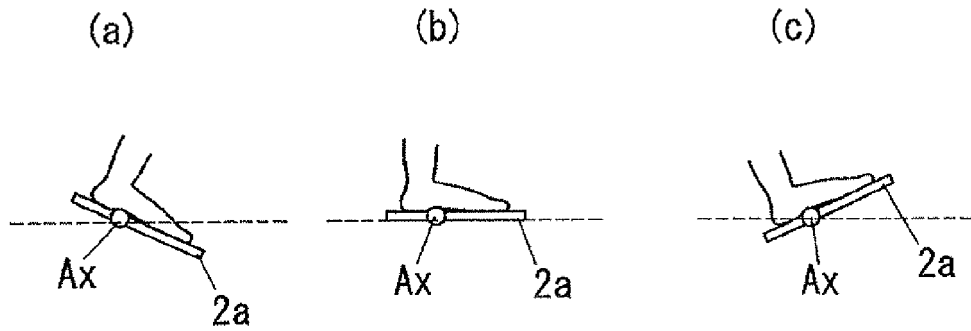

Fig. 10

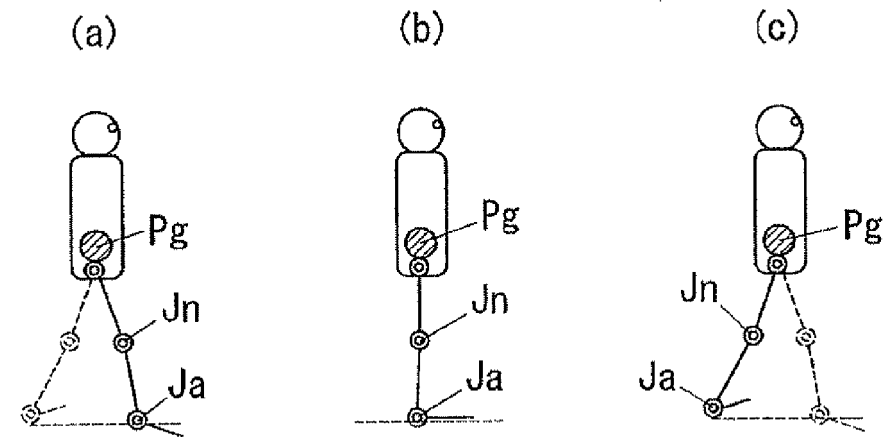

Fig. 11

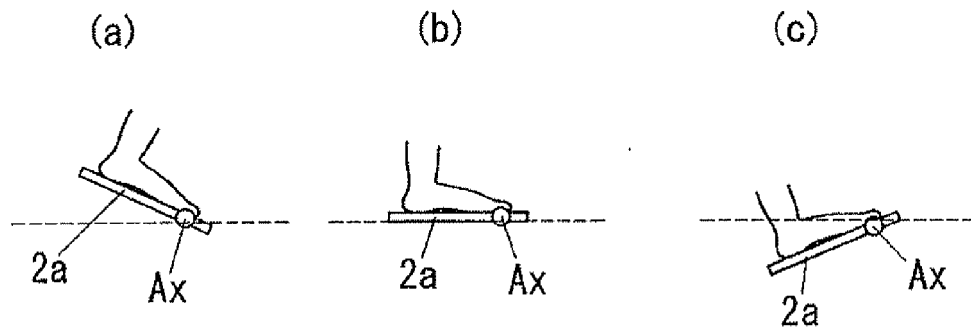

Fig. 12

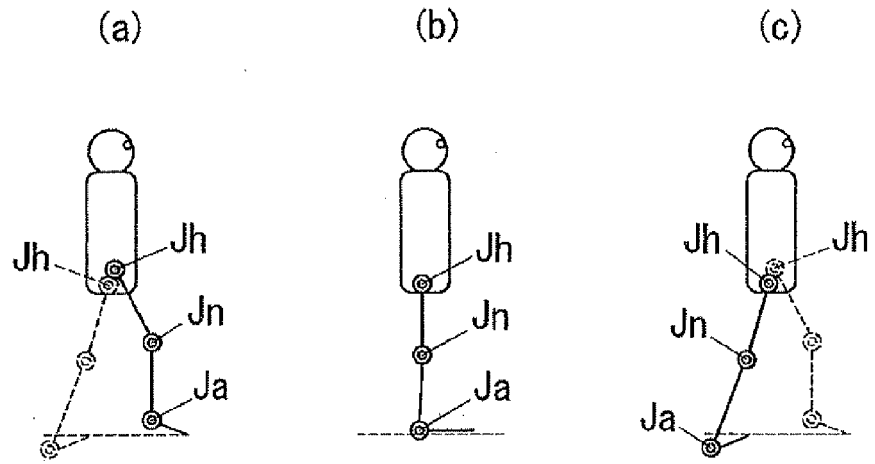

Fig. 13

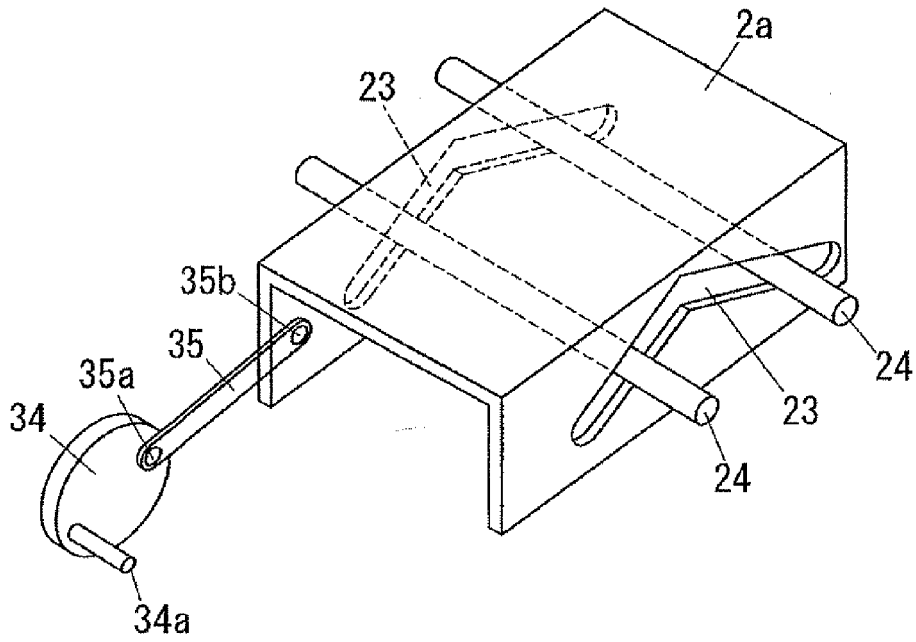

Fig. 14

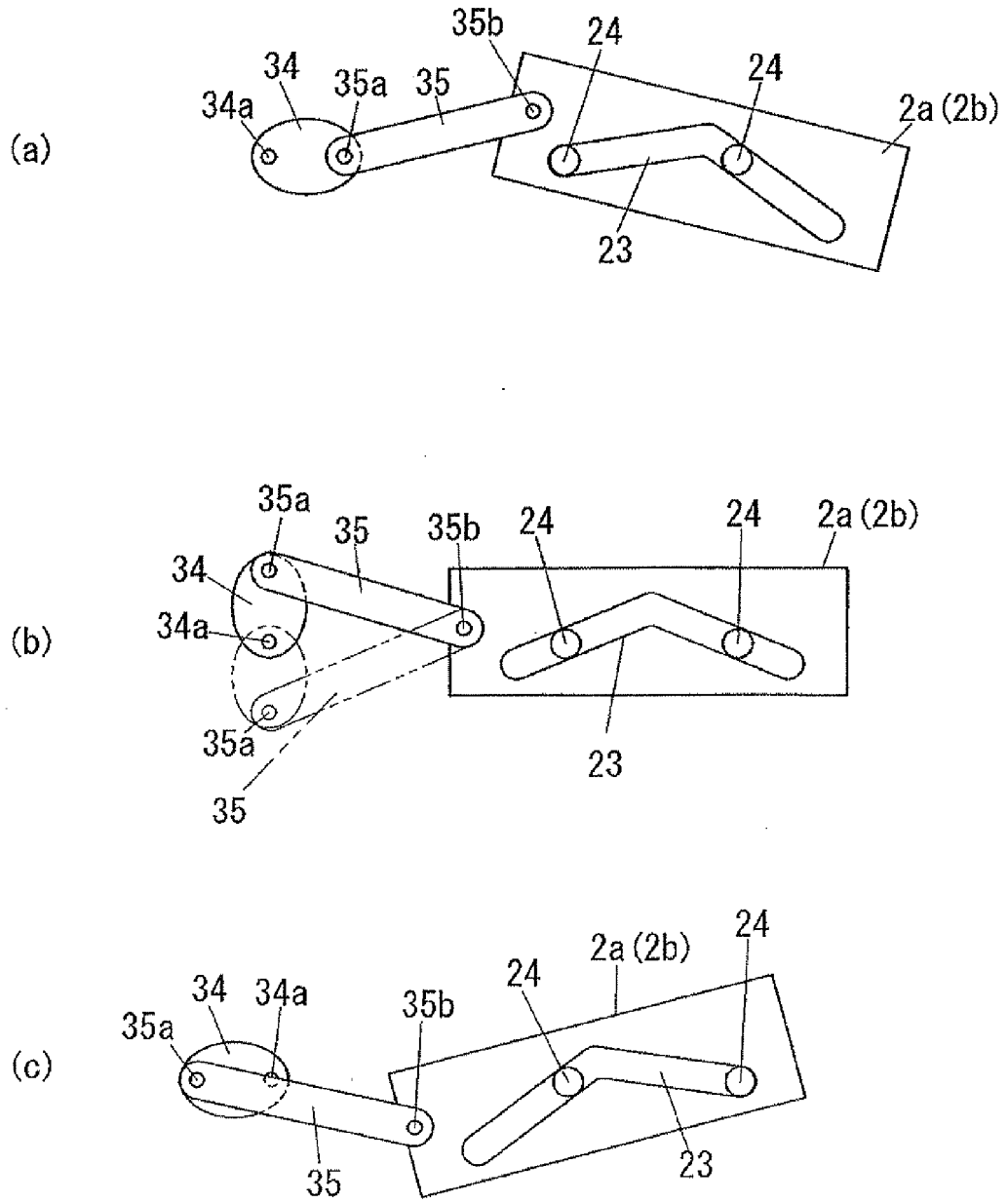

Fig. 15

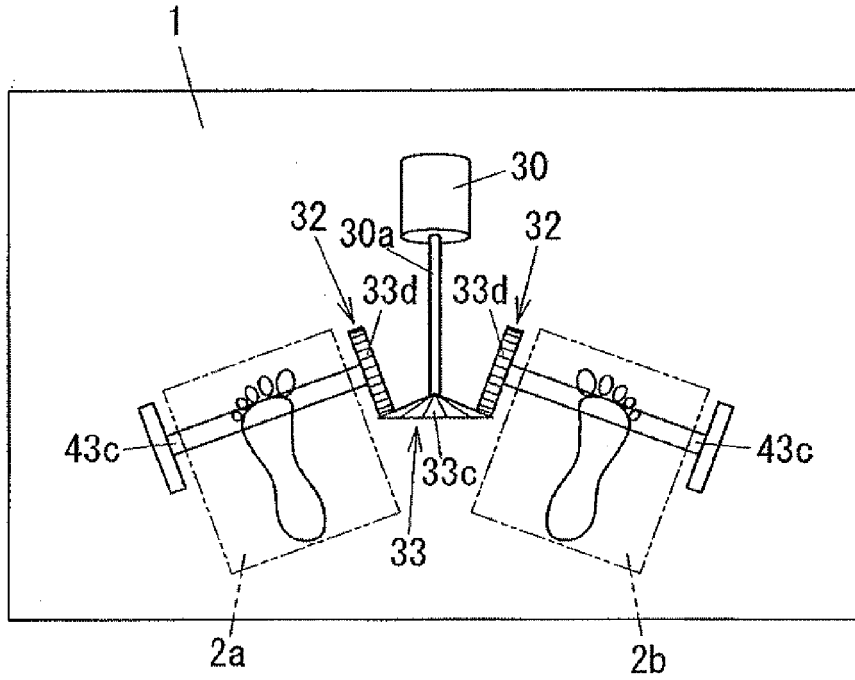

Fig. 16

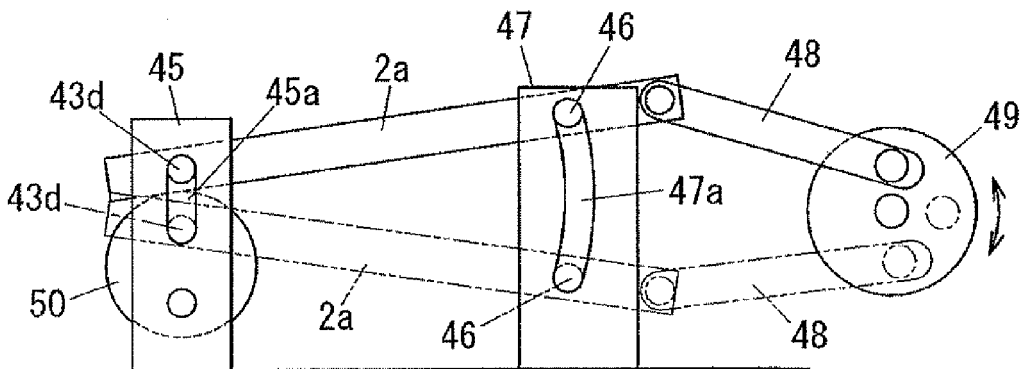

Fig. 17

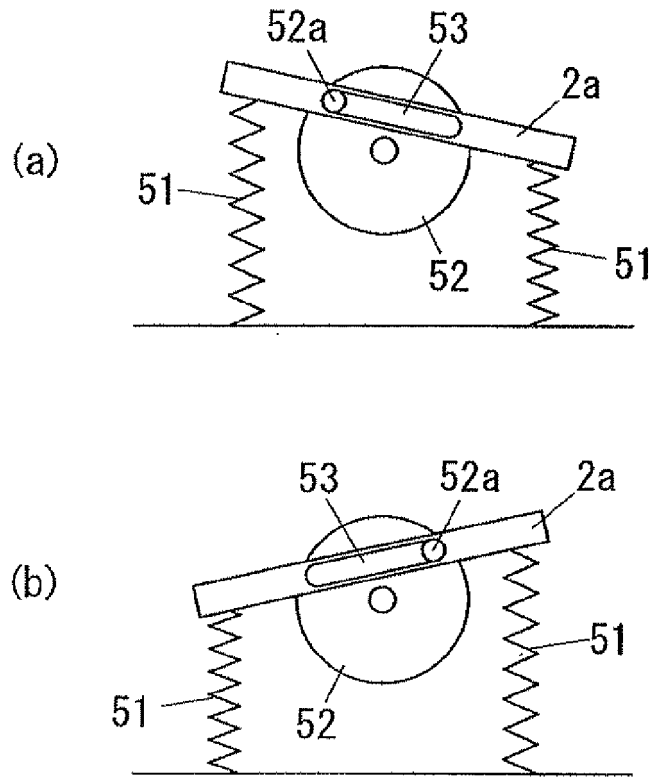

Fig. 18

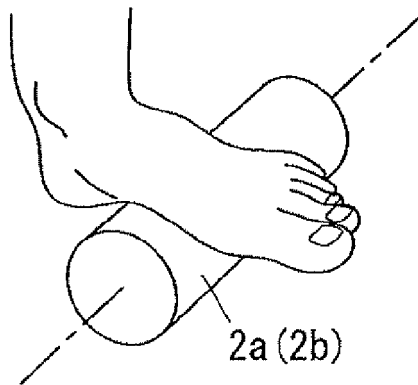
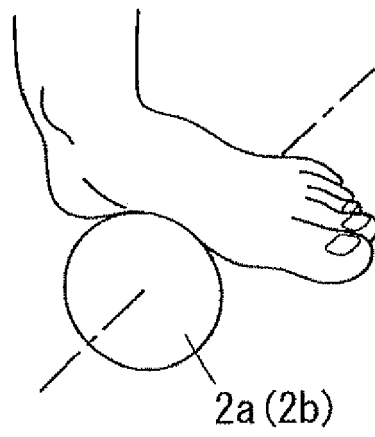

Fig. 19





EUROPEAN SEARCH REPORT

Application Number  
EP 11 18 9770

DOCUMENTS CONSIDERED TO BE RELEVANT			
Category	Citation of document with indication, where appropriate, of relevant passages	Relevant to claim	CLASSIFICATION OF THE APPLICATION (IPC)
X	US 2 969 060 A (SWANDA HOWARD F ET AL) 24 January 1961 (1961-01-24)	1,8	INV. A61H1/02 A63B23/04
Y	* column 2, line 3 - column 4, line 35; figures 1-4 *	2,3	
Y	----- EP 0 285 438 A2 (HEATON SAMUEL) 5 October 1988 (1988-10-05) * column 4, line 28 - column 8, line 5; figures 1-8 *	2,3	
X	----- EP 1 350 500 A1 (GALVEZ CAMPOS JOSE LUIS [ES]) 8 October 2003 (2003-10-08) * paragraph [0027]; figure 6 *	1	
A	----- US 2 093 830 A (FLATLEY JAMES J) 21 September 1937 (1937-09-21) * page 1, line 32 - page 2, line 38; figures 1-4 *	1-8	
			TECHNICAL FIELDS SEARCHED (IPC)
			A61H
The present search report has been drawn up for all claims			
Place of search Munich		Date of completion of the search 23 December 2011	Examiner Jekabsons, Armands
CATEGORY OF CITED DOCUMENTS		T : theory or principle underlying the invention E : earlier patent document, but published on, or after the filing date D : document cited in the application L : document cited for other reasons	
X : particularly relevant if taken alone Y : particularly relevant if combined with another document of the same category A : technological background O : non-written disclosure P : intermediate document		& : member of the same patent family, corresponding document	

1  
EPO FORM 1503\_03.82 (P04C01)

ANNEX TO THE EUROPEAN SEARCH REPORT  
ON EUROPEAN PATENT APPLICATION NO.

EP 11 18 9770

This annex lists the patent family members relating to the patent documents cited in the above-mentioned European search report. The members are as contained in the European Patent Office EDP file on  
The European Patent Office is in no way liable for these particulars which are merely given for the purpose of information.

23-12-2011

Patent document cited in search report		Publication date	Patent family member(s)	Publication date
US 2969060	A	24-01-1961	NONE	
-----				
EP 0285438	A2	05-10-1988	DE 3868658 D1	09-04-1992
			EP 0285438 A2	05-10-1988
			ES 2029714 T3	01-09-1992
			GB 2203651 A	26-10-1988
			US 4862875 A	05-09-1989
-----				
EP 1350500	A1	08-10-2003	AU 6397201 A	18-06-2002
			CA 2430837 A1	13-06-2002
			EP 1350500 A1	08-10-2003
			US 2004053753 A1	18-03-2004
			US 2007179411 A1	02-08-2007
			WO 0245644 A1	13-06-2002
-----				
US 2093830	A	21-09-1937	NONE	
-----				

**REFERENCES CITED IN THE DESCRIPTION**

*This list of references cited by the applicant is for the reader's convenience only. It does not form part of the European patent document. Even though great care has been taken in compiling the references, errors or omissions cannot be excluded and the EPO disclaims all liability in this regard.*

**Patent documents cited in the description**

- JP 2003290386 A [0003]