

FIG. 2(b)

## Description

### BACKGROUND OF THE INVENTION

#### 1. Field of the Invention

**[0001]** The present invention relates generally to ink cartridges, sets of ink cartridges, and ink cartridge determination systems.

#### 2. Description of Related Art

**[0002]** A known recording apparatus, such as an ink-jet recording apparatus, includes an ink-jet recording head and a mounting portion to which a known ink cartridge is mounted. When the known ink cartridge is mounted to the mounting portion, the known recording apparatus is configured to dispense ink from a plurality of nozzles to record an image on a sheet of paper.

**[0003]** Another known recording apparatus includes a carriage configured to receive another known ink cartridge. This known recording apparatus is configured to determine a type of the ink cartridge by sensing an intensity of light reflected by the ink cartridge. When the carriage and the ink cartridge move, the intensity of the reflected light is measured by a sensor of the recording apparatus, and based on the intensity, the type of the ink cartridge is determined. Such a known recording apparatus is described in US2005/0024454 A1 for example.

**[0004]** Yet another known recording apparatus includes a mounting portion which is separate from a carriage, and this known recording apparatus is configured to determine the type of another known ink cartridge when the ink cartridge is mounted to the mounting portion. Specifically, when the ink cartridge is mounted to the mounting portion, the recording apparatus detects the presence or absence of a signal blocking portion of the ink cartridge, and the type of the ink cartridge is determined based on the presence or absence of the signal blocking portion. Such a known recording apparatus is described in US 2005/0195225 A1 for example. Nevertheless, in this known recording apparatus, the speed with which various users mount the ink cartridge to the mounting portion may vary from user to user, such that the recording apparatus may reach different determinations from user to user. For example, if the speed with which the user mounts the ink cartridge to the mounting portion is greater than a predetermined speed, or if the user begins to insert the ink cartridge into the mounting portion and then partially removes the ink cartridge before finally fully inserting the ink cartridge into the mounting portion, the sensor may detect inaccurate information.

### SUMMARY OF THE INVENTION

**[0005]** Therefore, a need has arisen for ink cartridges, sets of ink cartridges, and ink cartridge determination

systems which overcome these and other shortcomings of the related art. A technical advantage of the present invention is that the configuration of the ink cartridge allows a recording apparatus to accurately determine information associated with the ink cartridge independent of the speed with which the user mount the ink cartridge to the printer and regardless of whether the user begins to insert the ink cartridge into the printer and then partially removes the ink cartridge before finally fully inserting the ink cartridge into the printer.

**[0006]** According to an embodiment of the present invention, an ink cartridge comprises a first signal blocking portion, a second signal blocking portion, and a third signal blocking portion. The first signal blocking portion is configured to either prevent a first signal from passing therethrough or to alter a path of the first signal when the first signal blocking portion receives the first signal, and the second signal blocking portion is configured to either prevent a second signal from passing therethrough or to alter a path of the second signal when the second signal blocking portion receives the second signal. Moreover, the third signal blocking portion is configured to either prevent the second signal from passing therethrough or to alter a path of the second signal when the third signal blocking portion receives the second signal.

**[0007]** According to an embodiment of the present invention, a set of ink cartridges comprises first and second ink cartridges. The second signal blocking portion of the first ink cartridge has a thickness configured to prevent the second signal from passing therethrough or alter the path of the second signal at a time that the first signal blocking portion initially prevents the first signal from passing therethrough or alters the path of the first signal. The second signal blocking portion of the second ink cartridge has a thickness configured not to prevent the second signal from passing therethrough or alter the path of the second signal at the time that the first signal blocking portion initially prevents the first signal from passing therethrough or alters the path of the first signal.

**[0008]** According to an embodiment of the present invention, an ink cartridge determination system comprises the ink cartridge and a recording apparatus. The recording apparatus comprises a cartridge mounting portion configured to mount the ink cartridge, a first sensor disposed in the cartridge mounting portion and comprising a first signal-emitting element configured to emit the first signal and a first signal-receiving element configured to receive the first signal, and a second sensor disposed in the cartridge mounting portion and comprising a second signal-emitting element configured to emit the second signal and a second signal-receiving element configured to receive the second signal, and a determiner. The first signal blocking portion is configured to either prevent the first signal from passing therethrough or to alter the path of the first signal at least during a mounting of the ink cartridge to the cartridge mounting portion. An intensity of the first signal received by the first signal-receiving element when the first signal is prevented from passing

through the first signal blocking portion or the path of the first signal is altered by the first signal blocking portion is different from an intensity of the first signal received by the first signal-receiving element when the first signal is not prevented from passing through the first signal blocking portion or the path of the first signal is not altered by the first signal blocking portion. The second signal blocking portion is configured to either prevent the second signal from passing therethrough or to alter the path of the second signal during the mounting of the ink cartridge to the cartridge mounting portion. The third signal blocking portion is configured to either prevent the second signal from passing therethrough or to alter the path of the second signal when the mounting of the ink cartridge to the cartridge mounting portion is completed. An intensity of the second signal received by the second signal-receiving element when the second signal is prevented from passing through the second signal blocking portion or the third signal blocking portion or the path of the second signal is altered by the second signal blocking portion or the third signal blocking portion is different from an intensity of the second signal received by the second signal-receiving element when the second signal is not prevented from passing through the second signal blocking portion or the third signal blocking portion or the path of the second signal is not altered by the second signal blocking portion or the third signal blocking portion. The determiner is configured to determine information associated with the ink cartridge based on the intensity of the second signal received by the second signal-receiving element at a time that the intensity of the first signal received by the first signal-receiving element initially changes during the mounting of the ink cartridge to the cartridge mounting portion. Moreover, the determiner may be configured to determine an amount of ink in the ink chamber based on the intensity of the second signal received by the second signal-receiving element when the mounting of the ink cartridge to the cartridge mounting portion is completed.

**[0009]** With these configurations, information associated with the ink cartridge is accurately determined. In addition, the amount of ink in the ink chamber may be determined.

**[0010]** Other objects, features, and advantages of embodiments of the present invention will be apparent to persons of ordinary skill in the art from the following description of preferred embodiments with reference to the accompanying drawings.

#### BRIEF DESCRIPTION OF DRAWINGS

**[0011]** For a more complete understanding of the present invention, the needs satisfied thereby, and the objects, features, and advantages thereof, reference now is made to the following description taken in connection with the accompanying drawings.

**[0012]** Fig. 1 is a cross-sectional, pattern diagram of a recording apparatus according to an embodiment of the present invention.

**[0013]** Figs. 2(a) and 2(b) are perspective views of an ink cartridge in which a movable member is in a second position and a first position, respectively, according to an embodiment of the present invention.

5 **[0014]** Figs. 2(c) and 2(d) are perspective views of an ink cartridge in which a movable member is in a second position and a first position, respectively, according to another embodiment of the present invention.

**[0015]** Figs. 3(a) and 3(b) are side views of the ink cartridge of Figs. 2(a) and 2(b), respectively.

10 **[0016]** Figs. 3(c) and 3(d) are side views of the ink cartridge of Figs. 2(c) and 2(d), respectively.

**[0017]** Figs. 4(a) and 4(b) are a front-face perspective view and a rear-face perspective view of a main body of the ink cartridge of Figs. 2(a) and 2(b).

15 **[0018]** Fig. 5 is a side view of the main body of Figs. 4(a) and 4(b).

**[0019]** Fig. 6 is a cross-sectional view taken along the line VI-VI of Fig. 4(a).

20 **[0020]** Fig. 7 is a partial, enlarged front-face cross-sectional view of the body of Figs. 4(a) and 4(b).

**[0021]** Fig. 8 is a cross-sectional view taken along the line VIII-VIII in Fig. 2(a).

**[0022]** Fig. 9 is a cross-sectional view taken along the line IX-IX in Fig. 2(b).

25 **[0023]** Figs. 10(a) and 10(b) are enlarged, cross-sectional views of an upper portion and a lower portion, respectively, of the main body of Figs. 4(a) and 4(b).

**[0024]** Figs. 11(a) and 11(b) are perspective and side views, respectively, of a movable member, according to another embodiment of the present invention.

**[0025]** Fig. 12 is a vertical, cross-sectional view of a cartridge mounting portion of a recording apparatus, according to an embodiment of the present invention.

30 **[0026]** Fig. 13 is a cross-sectional view of an ink cartridge being mounted to the cartridge mounting portion of Fig. 12.

**[0027]** Fig. 14 is a cross-sectional view of an ink cartridge mounted to the cartridge mounting portion of Fig. 12, in which a lock lever of the recording apparatus is in an open position.

**[0028]** Fig. 15 is a cross-sectional view of an ink cartridge mounted to the cartridge mounting portion of Fig. 12, in which the lock lever of the recording apparatus is in a closed position.

35 **[0029]** Fig. 16 is a block diagram of a main controller of the recording apparatus, according to an embodiment of the present invention.

**[0030]** Figs. 17(a) and 17(b) are exemplary timing diagrams of a sensor signal outputted from a first optical sensor and a second optical sensor, respectively, of the recording apparatus when a first ink cartridge is mounted to the cartridge mounting portion.

40 **[0031]** Figs. 17(c) and 17(d) are exemplary timing diagrams of a sensor signal outputted from the first optical sensor and the second optical sensor, respectively, of the recording apparatus when a second ink cartridge is mounted to the cartridge mounting portion.

**[0032]** Fig. 18 is a flowchart of a procedure performed by the main controller of the recording apparatus, according to an embodiment of the present invention.

**[0033]** Fig. 19 is a perspective view of a packaging arrangement comprising the ink cartridge of Figs. 2(a) and 2(b) enclosed in a packaging member, according to yet another embodiment of the present invention.

**[0034]** Fig. 20 is a cross-sectional view of an ink cartridge mounted to the cartridge mounting portion, according to another embodiment of the present invention.

**[0035]** Fig. 21 is a cross-sectional view of the ink cartridge being ejected from the cartridge mounting portion of Fig. 20, and Fig. 22(a) and 22(b) are side views of the ink cartridge of Figs. 2(a) and 2(b), respectively.

#### DETAILED DESCRIPTION OF EMBODIMENTS

**[0036]** Embodiments of the present invention and their features and technical advantages may be understood by referring to Figs. 1-21, like numerals being used for like corresponding portions in the various drawings.

**[0037]** Referring to Fig. 1, a recording apparatus 250 according to an embodiment of the present invention is depicted. The recording apparatus 250 comprises a paper feeding apparatus 252, a transferring apparatus 253, a recording unit 254, and a cartridge mounting portion 276. A paper feed tray 257 is provided at the bottom of the recording apparatus 250, and sheets of paper positioned on the paper feed tray 257 are fed, one by one, to a path 259 by the paper feeding apparatus 252.

**[0038]** The transferring apparatus 253 is disposed in the path 259, and comprises a first pair of transferring rollers 261 and a second pair of transferring rollers 262. The pair of transferring rollers 261 is positioned on the upstream side of the recording unit 254 in a paper-transferring direction, and the pair of transferring rollers 262 is positioned on the downstream side in the paper-transferring direction.

**[0039]** A sheet of paper fed to the path 259 is transferred toward a platen 264 by the pair of transferring rollers 261, and the recording unit 254 is positioned above the platen 264. An image is recorded on the sheet of paper passing over the platen 264 by the recording unit 254, and the sheet of paper then is discharged to a paper discharge tray 258 positioned on the downstream end of the path 259 by the pair of transferring rollers 262.

**[0040]** The recording unit 254 comprises a carriage 266 and a recording head 272 mounted to the carriage 266. The recording head 272 comprises a sub-tank 268 and a head control board 270, and has a plurality of nozzles 274 formed therein. The carriage 266 is slidably supported by a supporting rail, and is configured to slide in the direction vertical to the paper plane of Fig. 1. The sub-tank 268 is configured to store ink to be supplied to the nozzles 274. When image signals are supplied to the head control board 270, ink is discharged from the nozzles 274 toward the sheet of paper based on the image signals. The recording apparatus 250 comprises a main

controller 200 (shown in Fig. 16) for controlling the recording apparatus 250, and the image signals are outputted from the main controller 200 and supplied to the head control board 270.

**[0041]** An ink cartridge 10 is configured to be mounted to the cartridge mounting portion 276. The cartridge mounting portion 276 comprises a plurality of cases 280, each of which is configured to receive a corresponding ink cartridge 10 therein. For example, the cartridge mounting portion 276 comprises four cases 280, and each case 280 corresponds to an ink cartridge containing a different color of ink. The ink cartridge 10 is configured to be mounted to and removed from the cartridge mounting portion 276. The ink cartridge 10 comprises a main body 20, and the main body 20 comprises an ink chamber 100 configured to store ink therein, and ink is supplied from the ink chamber 100 to the recording head 272 via an ink tube 278.

**[0042]** In an embodiment of the present invention, two different ink cartridges may have different ink capacities or may store different initial amounts of ink, and may store the same color ink, e.g., black ink. For example, a first ink cartridge 10 and second ink cartridge 10' have different ink capacities or store different initial amounts of ink, and store the same color ink. Moreover, the recording apparatus 250 is configured, such that the ink cartridges 10 and 10' are mounted to the same case 280 of the cartridge mounting portion 276. The recording apparatus 250 is configured to determine which type of ink cartridge is mounted to the case 280.

**[0043]** Referring to Figs. 2(a), 2(b), 3(a), 3(b), and 4-10 (b), the ink cartridge 10 has a substantially flat, hexahedron shape. A width of the ink cartridge, as indicated by an arrow 31, is relatively short, and each of a height of the ink cartridge 10, as indicated by an arrow 32, and a depth of the ink cartridge 10, as indicated by an arrow 33, is greater than the width of the ink cartridge 10.

**[0044]** The ink cartridge 10 comprises a case, e.g., a main body 20, a movable member 21, a cover member 22, and at least one coil spring, e.g., a pair of coil springs 23 and 24. The main body 20 comprises an ink chamber 100 for storing ink. The movable member 21 and the cover member 22 encloses the main body 20 therein. Each of the main body 20, the movable member 21, and the cover member 22 is formed of a resin material, e.g., nylon, polyethylene, polypropylene, or the like, and combinations thereof.

**[0045]** The ink cartridge 10 is inserted into the recording apparatus in a direction indicated by an arrow 30 in an upright state. A front portion 20a of the main body is enclosed by the movable member 21, and a rear portion 20b of the main body 20 is enclosed by the cover member 22. Accordingly, in this embodiment of the present invention, the front portion 20a is protected by the movable member 21, and the rear portion 20b is protected by the cover member 22.

**[0046]** The movable member 21 is configured to slide in the depth direction, as indicated by the arrow 33, with

respect to the main body 20. The movable member 21 is configured to move with respect to main body 20. Specifically, movable member 21 is configured to move between a first position, as shown in Figs. 2(b) and 9, in which movable member 21 is at its furthest position from a front face 41 of the main body, and a second position, as shown in Figs. 2(a) and 8, in which movable member 21 is at its closest position to the front face 41. When the movable member 21 is at the first position, at least a portion of the movable member 21 is positioned further from the front face 41 than the ink supply portion 90 is positioned from the front face 41. In an embodiment, when a predetermined amount of force greater than the biasing force of the coil springs 23 and 24 is applied to the movable member 21, and thereby the movable member 21 moves from the first position to the second position, a rod 84 of an air intake portion 80 contacts the movable member 21 and is pressed by the movable member 21, and an ink supply portion 90 emerges from an inside of the movable member 21 to extend outside the movable member 21. When the predetermined amount of force is released from the movable member 21, and thereby the movable member 21 subsequently moves from the second position to the first position, the rod 84 separates from the movable member 21, and the ink supply portion 90 returns to the inside of the movable member 21. The entire moveable member 21 is configured to substantially simultaneously move in a first direction relative to the main body 20 when the coil springs 23 and 24 expand, and the entire moveable member 21 is configured to substantially simultaneously move in a second direction opposite the first direction when the coil springs 23 and 24 contract. Each of the first direction and the second direction is substantially parallel to each of the expansion direction and the contraction direction of the coil springs 23 and 24. In another embodiment, discussed in detail below and shown in Figs. 2(c), 2(d), 3(c), and 3(d), an opening 180' may be formed through a front wall 161 of the movable member 21 adjacent to and in alignment with the air intake portion 80, such that a component of the printer may apply the force to the rod 84 instead of the movable member 21 applying the force to the rod 84.

**[0047]** The main body 20 has a substantially flat, hexahedron shape. When the ink cartridge 10 is mounted to the mounting portion of the recording apparatus, the main body 20 is in an upright state. The main body 20 comprises the front face 41, a rear face 42, a top face 43, and a bottom face 44. The main body 20 also comprises a pair of side faces 45 and 46 which oppose each other, and each of the side faces 45 and 46 is connected to the front face 41, the rear face 42, the top face 43, and the bottom face 44. Each of side faces 45 and 46 has a surface area which is greater than each of a surface area of the front face 41, the rear face 42, the top face 43, and the bottom face 44.

**[0048]** The main body 20 comprises a frame 50, an arm 70, the air intake portion 80, and the ink supply por-

tion 90. Moreover, the side face 45 or the side face 46, or both, comprises a film, e.g., a translucent film. Specifically, the film is welded to the frame 50, such that the frame 50 is sealed by the film to define an ink chamber 100 therein. The frame 50 is formed of a translucent resin material, i.e., a transparent or semi-transparent resin material e.g. polyacetal, nylon, polyethylene, or polypropylene, and combinations thereof, to allow light to pass therethrough, and the frame 50 is formed by injection-molding. The frame 50 is sufficiently rigid, such that the shape of the frame 50 is not be altered in the expansion and contraction directions of the coil springs 23 and 24 when the coil sprints 23 and 24 expand and contract.

**[0049]** The frame 50 comprises an outer peripheral wall 51 and a plurality of inner walls 52. The inner walls 52 are positioned within the outer peripheral wall 51. The outer peripheral wall 51 and the inner walls 52 are integral and define the frame 50. The outer peripheral wall 51 and the inner walls 52 extend from the left side face 45 to the right side face 46 of the main body 20. The outer peripheral wall 51 has an annular shape extending along the front face 41, the top face 43, the rear face 42, and the bottom face 44, and forms a space inside. Accordingly, an opening 57a is formed on the left side face 45 of the frame 50, and an opening 57b is formed on the right side face 46.

**[0050]** The films are welded to the side faces 45 and 46 of the frame 50, respectively, via ultrasonic welding, and the opening 57a and the opening 57b are covered by the respective films, such that a space surrounded by the outer peripheral wall 51 and the films form the ink chamber 100. Alternatively, the films may be omitted, and the frame 50 may have a parallelepiped, container shape, such that the frame 50 defines the ink chamber 100 therein.

**[0051]** The inner walls 52 are positioned within a space surrounded by the outer peripheral wall 51, and the films are welded to the outer edge portions of the inner walls 52 on the sides of the side faces 45 and 46. Accordingly, the film is prevented from sagging. Moreover, when the movable member 21 and the cover member 22 are deformed toward the main body 20, the deformation of the movable member 21 and the cover member 22 is restricted by the inner walls 52. Accordingly, damage to the main body 20 and the films is prevented.

**[0052]** An ink introduction port 150 is formed in the rear face 42 of the frame 50. The ink introduction port 150 has a substantially cylindrical hole formed therein, which extends from the rear face 42 toward the ink chamber 100, and the ink introduction port 150 is in fluid communication with an interior of the ink chamber 100. The ink introduction port 150 is configured to introduce ink into the interior of the ink chamber 100 therethrough when the ink cartridge 10 is manufactured. After the ink chamber 100 is filled with ink, the ink introduction port 150 is closed by positioning a plug in the ink introduction port 150.

**[0053]** A translucent portion 140 is positioned at the

front face 41 of the frame 50 and extends from the ink chamber 100. An amount of ink stored in the ink chamber is optically or visually detected through the translucent portion 140. The translucent portion 140 is integral with the frame 50, and is formed of the same material as the frame 50, e.g., the translucent portion 140 is formed of a translucent resin material to allow light to pass there-through.

**[0054]** The translucent portion 140 projects outward from a center portion of the front face 41 of the main body 20 in a direction opposite from the ink chamber 100. The translucent portion 140 is partitioned by five rectangular walls and has a substantially a hollow box shape. For example, the translucent portion 140 is partitioned by a front wall 140a, a pair of side walls 140b, top wall 140c, and bottom wall 140d. The front wall 140a extends parallel to the front face 41 and is separated from the front face 41 by a predetermined distance. The pair of side walls 140b is connected to the front face 41 and the front wall 140a, the top wall 140c is connected to top ends of the front wall 140a and the side walls 140b, and the bottom wall 140d is connected to bottom ends of the front wall 140a and the side walls 140b. Moreover, the width of the front wall 140a is less than the width of the front face 41.

**[0055]** The translucent portion 140 is configured to be sandwiched between a light-emitting element (not shown) and a light-receiving element (not shown) of an optical sensor (not shown), e.g. photo interrupter, mounted to the recording apparatus. Light emitted by the light-emitting element passes through the side walls 140b and is received by the light-receiving element.

**[0056]** The translucent portion 140 has an inner space 142 formed therein, which is defined by the front wall 140a, the side walls 140b, the top wall 140c and the bottom wall 140d. There is no wall positioned between the inner space 142 and the ink chamber 100, and the inner space 142 is configured to be in fluid communication with the interior of the ink chamber 100. A signal blocking portion 72 of the arm 70 is configured to selectively enter into and be removed from the inner space 142 based on an amount of ink within the ink chamber 100.

**[0057]** The arm 70 is used in detecting the amount of ink stored in the ink chamber 100. The arm 70 comprises the signal blocking portion 72 at one end thereof, and a float portion 73 at the other end thereof. The arm 70 is pivotably supported at a rib 74 extending upright from the widthwise center of the outer peripheral wall 51. The specific gravity of the float portion 73 is less than the specific gravity of ink stored in the ink chamber 100. The float portion 73 has a hollow formed therein, and floats on liquid, such that the float portion 73 moves upward and downward based on the amount of ink within the ink chamber 100, and the arm 70 pivots based on the movement of the float portion 73. The rib 74 is positioned at the outer peripheral wall 51 adjacent to a corner of the front face 41 and the bottom face 44. Referring to Fig. 6, the rib 74 comprises a supporting portion 77 configured

to pivotably support the arm 70.

**[0058]** Referring to Figs. 4(a)-6, the arm 70 is positioned, such that the signal blocking portion 72 is positioned in the inner space 142 when a sufficient amount of ink is stored in the ink chamber 100. For example, the signal blocking portion 72 contacts the bottom wall 140d of the translucent portion 140 to maintain the signal blocking portion 72 within the inner space 142 of the translucent portion. Moreover, when the amount of ink in the ink chamber 100 is less than a predetermined amount of ink, the float portion 73 moves downward, and the signal blocking portion 72 moves out of the inner space 142. Consequently, whether a sufficient amount of ink remains in the ink chamber 100 is detected by monitoring whether the signal blocking portion 72 is positioned within the inner space 142. For example, an optical sensor, such as a photo interrupter, is used to monitor whether the signal blocking portion 72 is positioned within the inner space.

**[0059]** Referring to Fig. 7, the air intake portion 80 comprises a cylindrical valve storage chamber 55 formed in the front face 41 above the translucent portion 140. The valve storage chamber 55 is open to the outside of main body 20 at an end 82 thereof. The valve storage chamber 55 extends in the depth direction of the main body 20, and is in fluid communication with the interior of the ink chamber 100 at the other end thereof.

**[0060]** The air intake portion 80 also comprises a valve mechanism for selectively opening and closing a path extending from the end 82 of the valve storage chamber 55 to the interior of the ink chamber 100. For example, the air intake portion 80 comprises a valve element 87, a spring 86, a sealing member 83, and a cap 85. The valve element 87 is configured to slide in the depth direction of the main body 20 in the valve storage chamber 55. The valve element 87 comprises a lid 88 and the rod 84. The cap 85 is attached to the outer edge of the end 82 of the valve storage chamber 55, sandwiching the sealing member 83 therebetween. The cap 85 and the sealing member 83 have through holes formed there-through. When the cap 85 and the sealing member 83 are attached to the outer edge of the end 82, an air communicating port 81 is formed by the through holes, and an inside and an outside of the valve storage chamber 55 is in fluid communication via air communicating port 81. The rod 84 is inserted into the air communicating port 81, and the diameter of the rod 84 is less than the diameter of the air communicating port 81, such that a gap for allowing air flow is formed between the rod 84 and the interior walls of the air communicating port 81. The rod 84 projects outward from the center of the lid 88 through the air communicating port 81.

**[0061]** When the valve element 87 slides in the valve storage chamber 55, the lid 88 slides between a position in which the lid 88 contacts the sealing member 83 and a position in which the lid 88 is separated from the sealing member 83. When the lid 88 contacts the sealing member 83, the air communicating port 81 is closed, and when the lid 88 separates from the sealing member 83, the air

communicating port 81 is opened.

**[0062]** In the valve storage chamber 55, the spring 86 urges or biases the valve element 87 in the direction to close the path extending from the inside of the valve storage chamber 55 to the outside of the valve storage chamber 55, thereby causing the lid member 88 to contact the sealing member 83. When the rod 84 is pressed toward the valve storage chamber 55, the lid 88 of the valve element 87 separates from the sealing member 83 against urging force of the spring 86. Accordingly, the path extending from the inside of the valve storage chamber 55 to the outside of the valve storage chamber 55 is opened, and the communication between the interior of the ink chamber 100 and the outside of the main body 20 via the air intake portion 80 is established. With air flowing in and out of the ink chamber 100 via the air intake portion 80, the pressure of the interior of the ink chamber 100 is equalized as the ambient pressure.

**[0063]** Referring to Fig. 7, the ink supply portion 90 comprises a cylindrical valve storage chamber 54 formed in the front face 41 below the translucent portion 140, and the valve storage chamber 54 is open to the outside of the main body at an end 92 thereof. The valve storage chamber 54 extends in the depth direction of the main body 20, and is in fluid communication with the interior of the ink chamber 100 at the other end thereof.

**[0064]** The ink supply portion 90 also comprises a valve mechanism for selectively opening and closing an ink path extending from the end 92 of the valve storage chamber 54 to the interior of the ink chamber 100. The ink supply portion 90 comprises a valve element 97, a spring 96, a sealing member 93, and a cap 95.

**[0065]** The cap 95 is attached to the outer edge of the end 92 of the valve storage chamber 54, sandwiching the sealing member 93 therebetween. The cap 95 and the sealing member 93 have through holes formed there-through. When the cap 95 and the sealing member 93 are attached to the outer edge of the end 92 of the valve storage chamber 54, an ink supply port 91 is formed by the through holes, and the ink supply port 91 communicates an inside and an outside of the valve storage chamber 54. A tube is inserted into the ink supply port 91 when the ink cartridge 10 is mounted to the cartridge mounting portion 276.

**[0066]** In the valve storage chamber 54, the spring 96 urges or biases the valve element 97 in the direction to close the ink path, such that the valve element 97 contacts the sealing member 93 and communication between the interior of the ink chamber 100 and the outside of the main body 20 is prevented. When the tube is inserted into the ink supply port 91, the tube pushes the valve element 97, and the valve element 97 separates from the sealing member 93 against the urging force of the spring 96, and the ink supply port 91 is opened. Accordingly, the communication between the interior of the ink chamber 100 and the outside of the main body 20 via the ink supply portion 90 is established, and the ink in the ink chamber 100 is supplied through the tube to the

recording apparatus 250.

**[0067]** A recessed portion 59 is formed in the top face 43 of the frame 50, and a recessed portion 60 is formed in the bottom face 44 of the frame 50. The recessed portions 59 and 60 engage with projecting strips 210 and 211 (shown in Fig. 8), respectively, formed on the inner surface of the cover member 22 when the rear portion 20b of the main body 20 is covered by the cover member 22. The projecting strip 210 is fitted to the recessed portion 59, and the projecting strip 211 is fitted to the recessed portion 60, to provide secure engagement between the rear portion 20b and the cover member 22.

**[0068]** Referring to Fig. 6, a spring storage chamber 110 is formed in the front face 41 above the valve storage chamber 55, and a spring storage chamber 111 is formed in the front face 41 below the valve storage chamber 54. The spring storage chambers 110 and 111 are substantially cylindrical chambers extending from the front face 41 toward an ink chamber 100, such that at least a rear portion of spring storage chambers 110 and 111, respectively, define a portion of front face 41. Referring to Fig. 8, the coil springs 23 and 24 are positioned within the valve storage chambers 110 and 111, respectively. For example, each of the coil springs 23 and 24 is coupled to the front face 41 at one end and is coupled to the movable member 21 at the other end. Specifically, the coil springs 23 and 24 are coupled to the front face 41 and the movable member 21 by direct contact between the coil springs 23 and 24 and the front face 41 and the movable member 21, or by indirect contact between the coil springs 23 and 24 and the front face 41 and the movable member 21, *i.e.*, with at least one other element positioned between the coil springs 23 and 24 and the front face 41 and the movable member 21. The coil springs 23 and 24 are configured to resiliently urge the movable member 21 away from the front face 41 by applying a biasing force to the movable member 21. Moreover, in order to stably and evenly urge the movable member 21, the spring storage chamber 110 and the spring storage chamber 111 are sufficiently separated from each other in the height direction of the main body 20, *e.g.*, are positioned adjacent to opposite ends of the front face 41 in the height direction. In other words, the coil spring 23 is positioned closer to the upper end of the front face 41 than to the lower end of the front face 41, and the coil spring 24 is positioned closer to the lower end of the front face 41 than to the upper end of the front face 41.

**[0069]** A supporting member 115 is formed at an front end of the top face 43 of the frame 50. The supporting member 115 supports the movable member 21, such that the movable member 21 slides with respect to the main body 20, and the supporting member 115 limits the sliding range of the movable member 21. The movable member 21 is slidably supported at two points by the supporting member 115 and a supporting member 116 described later.. The supporting member 115 is integral with the frame 50. The supporting member 115 comprises a first



portion 118 extending vertically upward from the top face 43, a second portion 119 extending from an top end of the first portion 118 in the direction of insertion 30 in parallel to the top face 43, and a hook portion 120 formed at a front end of the second portion 119 and extending upward. A gap 122 is be formed between the second portion 119 and the top face 43, which allows the second portion 119 to bend in the height direction of the main body 20.

**[0070]** The supporting member 116 has substantially the same shape as the supporting member 115, and is positioned at a front end of the bottom face 44 of the frame 50. The supporting member 116 is integral with the frame 50, and comprises a first portion 124 extending vertically downward from the bottom face 44, a second portion 125 extending from an end of the first portion 124 in the direction of insertion 30 in parallel to the bottom face 44, and a hook portion 126 formed at an front end of the second portion 125 and extending downward.

**[0071]** Referring to Figs. 2(a)-3(b) and Figs. 8-10(b), the movable member 21 and the cover member 22, according to an embodiment of the present invention, are depicted. The cover member 22 has a container shape, and is configured to accommodate the rear portion 20b of the main body 20 therein. The cover member 22 has a flat shape corresponding to the outer shape of the rear portion 20b. The cover member 22 comprises a rear wall 212 facing and covering the rear face 42 of the main body 20, a top wall 213 facing and covering the top face 43 of the main body 20, a bottom wall 214 facing and covering the bottom face 44 of the main body 20, a left wall 215 facing and covering the left side face 45 of the main body 20, and a right wall 216 facing and covering the right side face 46 of the main body 20. The walls 212-216 define a space therein which is configured to accommodate the rear portion 20b. In an embodiment, a portion of the top wall 213 of the cover member 22 and a portion of the top face 43 of the main body 20 defines a latching recess 1000 therebetween. In another embodiment, a latching recess may be formed in the top face 43 of the main body 20, or may be formed in the top wall 213 of the cover member 22.

**[0072]** The projecting strips 210 and 211 are positioned on the inner surface of the cover member 22 adjacent to the opening of the cover member 22. The projecting strips 210 and 211 are at positions corresponding to the recessed portions 59 and 60. The projecting strip 210 is fitted to the recessed portion 59 formed in the top face 43 of the main body 20, and the projecting strip 211 is fitted to the recessed portion 60 formed in the bottom face 44 of the main body 20. Accordingly, the main body 20 and the cover member 22 is securely engaged.

**[0073]** The movable member 21 has a container shape, and is configured to accommodate the front portion 20a of the main body 20 therein. The movable member 21 has a flat shape corresponding to the outer shape of the front portion 20a. The movable member 21 comprises a front wall 161 facing the front face 41 of the main

body 20, a top wall 163 covering the top face 43 of the main body 20, a bottom wall 164 covering the bottom face 44 of the main body 20, a left wall 165 covering the left side face 45 of the main body 20, and a right wall 166 covering the right side face 46 of the main body 20. The walls 163-166 define a space therein which is configured to accommodate the front portion 20a.

**[0074]** The left wall 165 and the right wall 166 extend from the front wall 161 in the depth direction of the main body 20 and cover the left side face 45 and the right side face 46 of the main body 20. Therefore, when the movable member 21 slides, the left wall 165 and the right wall 166 act as guide surfaces for the left side face 45 and the right side face 46, such that the movable member 21 slides smoothly.

**[0075]** In an embodiment of the present invention, at least a portion of the movable member 21 has substantially the same color as the color of ink stored in the ink chamber 100, such that the movable member 21 readily indicates the ink color to a user.

**[0076]** The movable member 21 comprises a signal blocking arrangement 185, a signal blocking arrangement 186, a cutout 187 formed therethrough, supporting bars 168 and 169, slide grooves 171 and 172, a pressing portion 174, and an opening 180 formed therethrough.

**[0077]** Referring to Figs. 2(a)-3(b), the cutout 187 is formed at a center of the front wall 161, and the cutout 187 is configured to expose the translucent portion 140 to the outside when the movable member 21 is in the second position, such that at least a portion of the translucent portion 140 extends through the cutout 187 when the movable member 21 is in the second position. For example, the cutout 187 is formed by removing rectangular portions from the front wall 161 and the side walls 165 and 166, facing the front wall 140a and the side walls 140b of the translucent portion 140. The cutout 187 extends from the front wall 161 rearwardly in the direction of insertion 30. When the ink cartridge 10 is mounted to the cartridge mounting portion 276 (shown in Fig. 12), a light-emitting element and a light-receiving element of an optical sensor 230 (shown in Fig. 12) sandwich the cutout 187. Therefore, light emitted from the light-emitting element passes through the cutout 187, and the side wall 140b of the translucent portion 140 is irradiated with the light.

**[0078]** The signal blocking arrangement 185 comprises a signal blocking portion 189 projecting from the front wall 161 in the direction of insertion 30. The signal blocking portion 189 is bridged over the cutout 187 in the vertical direction on the front wall 161. The signal blocking portion 189 has a plate shape, and a space 190 is formed behind the signal blocking portion 189. The ends of the signal blocking portion 189 in the width direction and the cutout 187 forms rectangular openings in the side walls 165 and 166, respectively.

**[0079]** Referring to Fig. 12, the signal blocking portion 189 is configured to enter into an optical path 231 of the optical sensor 230 provided on the cartridge mounting

portion 276 during the mounting of the ink cartridge 10 into the cartridge mounting portion 276. The signal blocking portion 189 is formed of a resin material which does not allow light to pass therethrough or alters the path of light traveling therethrough. For example, the signal blocking portion 189 may be formed of a resin material including a black pigment. Alternatively, the signal blocking portion 189 may be a prism formed of a transparent resin material. The signal blocking arrangement 186 is configured to enter into an optical path 236 of an optical sensor 235 provided on the cartridge mounting portion 276 during the mounting of the ink cartridge 10 to the cartridge mounting portion 276. The signal blocking arrangement 186 is formed of a resin material which does not allow light to pass therethrough or alters a path of light passing therethrough. Referring to Figs. 2(a)-3(b), the signal blocking arrangement 186 is positioned at or adjacent to a distal end of the top wall 163, and the signal blocking arrangement 186 projects from the front wall 161 away from the front wall 161. The signal blocking arrangement 186 comprises a signal blocking portion 191, e.g., a rib portion, and a pair of grooves 192 is formed on opposite sides of the signal blocking portion 191. The signal blocking portion 191 is inserted into the optical path 236 of the optical sensor 235. The signal blocking portion 191, the signal blocking portion 189, and the ink supply portion 90 intersect a first plane, e.g. a plane which is parallel with the arrow 32 and the arrow 33 of Figs. 2(a)-2(d), and the signal blocking portion 189 and the signal blocking portion 72 intersect a second plane which is perpendicular to the first plane, e.g., a plane which is parallel with the arrow 31 and the arrow 33 of Figs. 2(a)-2(d), when a sufficient amount of ink is stored in the ink chamber 100 and the signal blocking portion 72 is positioned in the inner space 142. With this configuration, a later-described procedure for determining the type of the ink cartridge is readily performed.

**[0080]** The projecting portion 181 is positioned at or adjacent to a lower end of the front wall 161, and projects away from the front wall 161. Distal ends of the projecting portion 181 and the signal blocking arrangement 186 contact the innermost wall surface of the cartridge mounting portion 276 when the ink cartridge 10 is mounted to the cartridge mounting portion 276.

**[0081]** The supporting bar 168 is configured to support the coil spring 23, and the supporting bar 169 is configured to support the coil spring 24. The supporting bars 168 and 169 are positioned on a surface of the front wall 161 facing the front face 41 of the main body 20. The supporting bar 168 is at a position corresponding to the spring storage chamber 110, and the supporting bar 169 is at a position corresponding to the spring storage chamber 111.

**[0082]** Referring to Figs. 10(a) and 10(b), the supporting bars 168 and 169 extend from the surface of the front wall 161 in the depth direction of the main body 20. When the front portion 20a of the main body 20 is inserted into the movable member 21 in a state in which the coil spring

23 is stored in the spring storage chamber 110 and the coil spring 24 is stored in the spring storage chamber 111, the supporting bar 168 is inserted into the coil spring 23 and the supporting bar 169 is inserted into the coil spring 24. Accordingly, the coil springs 23 and 24 are supported by the supporting bars 168 and 169, respectively. The direction of expansion and contraction of the coil springs 23 and 24 is limited to the depth direction of the main body 20.

**[0083]** The coil springs 23 and 24 are compression coil springs, i.e., the coil springs 23 and 24 are compressed and stored in the spring storage chambers 110 and 111 when the front portion 20a is inserted into the movable member 21. Therefore, the coil springs 23 and 24 urge or bias the movable member 21 in the direction away from the front face 41 of the main body 20 independent of the position of the movable member 21.

**[0084]** Referring to Figs. 2(a) and 2(b), the slide groove 171 is formed in the top wall 163, and a cross-sectional shape of the slide groove 171 is substantially an inverted U-shape. Referring to Fig. 10(a), the supporting member 115 is inserted into the slide groove 171, and a projecting strip 182 extends from a bottom surface of the top wall 163 toward an interior of the slide groove 171. Therefore, the slide groove 171 is narrowed in part by the projecting strip 182. The slide groove 172 is formed in the bottom wall 164, and a cross-sectional shape of the slide groove 172 is substantially a U-shape. As shown in Fig. 10(b), the supporting member 116 is inserted into the slide groove 172, and a projecting strip 183 extends from a top surface of the bottom wall 164 toward an interior of the slide groove 172. Therefore, the slide groove 172 is narrowed in part by the projecting strip 183.

**[0085]** During insertion of the front portion 20a of the main body 20 into the movable member 21, the supporting member 115 is inserted into the slide groove 171, and the supporting member 116 is inserted into the slide groove 172. When the supporting member 115 is inserted into the slide groove 171, the projecting strip 182 and the hook portion 120 contact each other. Then, when the supporting member 115 is further inserted, the supporting member 115 bends toward the gap 122, and the hook portion 120 climbs over the projecting strip 182 while a bevel 182a of the projecting strip 182 and a bevel 120a of the hook portion 120 slide over each other. When the hook portion 120 has climbed over the projecting strip 182 once, the movable member 21 and the main body 20 are not disassembled because the hook portion 120 is received by the projecting strip 182 when the disassembly is attempted. The supporting member 116 is also inserted into the slide groove 172 in the same manner.

**[0086]** When the front portion 20a is inserted into the movable member 21, the movable member 21 is urged away from the front face 41 by the coil springs 23 and 24. Therefore, unless an external force is applied to the movable member 21, the movable member 21 remains in the first position (shown in Figs. 2(b) and 9) corresponding to the movable member's 21 furthest distance

from front face 41 of the main body 20. The movable member 21 remains in the first position by the contact between the projecting strip 182 and the hook portion 120 and the contact between the projecting strip 183 and the hook portion 126. On the other hand, when an external force is applied to the front face of the movable member 21, the movable member 21 slides from the first position to the second position (shown in Figs. 2(a) and 8) corresponding to the movable member's 21 closest distance to front face 41 of the main body 20.

**[0087]** Referring to Figs. 8 and 9, the pressing portion 174 is positioned on the surface of the front wall 161 facing the front face 41 of the main body 20. The pressing portion 174 is at a position corresponding to the rod 84 of the air intake portion 80. The pressing portion 174 is separated from a distal end of the rod 84 when the movable member 21 is in the first position, and the pressing portion 174 comes into contact with the distal end of the rod 84 while the movable member 21 slides from the first position toward the second position. Then, when the movable member 21 further slides toward the second position, the rod 84 is pushed toward the ink chamber 100 to open the air communicating port 81.

**[0088]** The opening 180 is formed through the front wall 161 at a position adjacent to a lower end of the front wall 161, and is formed at a position corresponding to the ink supply portion 90. The diameter of the opening 180 is greater than the diameter of the cap 95 of the ink supply portion 90, such that the cap 95 is inserted into and through the opening 180. When the movable member 21 is in the first position, the entire ink supply portion 90 is positioned within the movable member 21, such that the entire ink supply portion 90 is recessed from the opening 180. As the movable member 21 moves from the first position to the second position, at least a portion of the ink supply portion 90 moves into and then passes through the opening 180 to protrude from the front wall 161. Referring to Figs. 2(a), 2(b), 3(a), and 3(b), in an embodiment of the present invention, the air intake portion 80 is covered by the front wall 161, such that the air intake portion 80 is not exposed to the outside of the ink cartridge 10. In this embodiments, relatively small air holes (not numbered but shown in Figs. 2(a) and 2(b)) are formed in front wall 161 to allow air to be drawn into the air intake portion 80. Nevertheless, referring to Figs. 2(c), 2(d), 3(c), and 3(d), an opening 180' may be formed through the front wall 161 adjacent to and aligned with the intake portion 80. In this embodiment, when the movable member 21 is in the first position, the entire air intake portion 80 is positioned within the movable member 21, such that the entire air intake portion 80 is recessed from the opening 180. As the movable member 21 moves from the first position to the second position, the air intake portion remains entirely within the movable member 21, however, the air intake portion moves closer to the opening 180'. In this embodiments, air is drawn into the ink chamber 100 when a component of the printer contacts and applies a force to the rod 84 of the air intake portion

80 via opening 180'.

**[0089]** Referring to Figs. 11(a) and 11(b), in an embodiment of the present invention, ink cartridge 10 may be replaced by ink cartridge 10'. Specifically, in ink cartridge 10', the signal blocking arrangement 185 is replaced by a signal blocking arrangement 195 which has a different shape than the signal blocking arrangement 185. The signal blocking arrangement 195 comprises a signal blocking portion 199 projecting from the front wall 161. The signal blocking portion 199 is bridged over the cutout 187 in the vertical direction on the front wall 161. The signal blocking portion 199 comprises a front wall and a pair of side walls 198 at both ends in the width direction. The side walls 198 extend from the front wall of the signal blocking portion 199 to the front wall 161 of the movable member 21. The side walls 198 and the cutouts 187 form rectangular openings in the side walls 165 and 166. The signal blocking portion 199 is configured to enter into the optical path 231 of the optical sensor 230 provided on the cartridge mounting portion 276 during the mounting of the ink cartridge 10 to the cartridge mounting portion 276. The signal blocking portion 199 is formed of a resin material which does not allow light to pass therethrough or alters the path of light passing therethrough. The signal blocking portion 191, the signal blocking 199, and the ink supply portion 90 intersect a first plane, e.g. a plane which is parallel with the arrow 32 and the arrow 33 of Figs. 2(a)-2(d), and the signal blocking portion 199 and the signal blocking portion 72 intersect a second plane which is perpendicular to the first plane e.g., a plane which is parallel with the arrow 31 and the arrow 33 of Figs. 2(a)-2(d), when a sufficient amount of ink is stored in the ink chamber 100 and the signal blocking portion 72 is positioned in the inner space 142. With this configuration, a later-described procedure for determining the type of the ink cartridge is readily performed.

**[0090]** Referring to Fig. 12, according to an embodiment of the present invention, the cartridge mounting portion 276 comprises a plurality, e.g., four, cases 280 corresponding to different colors, e.g., cyan, magenta, yellow, and black, arranged in parallel in the widthwise direction. Each case 280 comprises a case body 281 and a lock lever 283. The case body 281 comprises a storage chamber 282 configured to selectively store the ink cartridge 10 and 10' therein, and an opening 284 is formed through the front side of the case body 281. The case 280 is configured to allow the ink cartridge 10 and 10' to be mounted to and removed from the case body 281 via the opening 284.

**[0091]** The optical sensor 230 and the optical sensor 235 are positioned on the closed end side of the storage chamber 282. The optical sensor 230 is positioned at a wall surface 286 which forms the closed end of the storage chamber 282. The optical sensor 230 is configured (a) to detect the type of the ink cartridge 10 and 10' mounted to the case 280; and (b) to detect whether the amount of ink in the ink cartridge 10 and 10' is less than or equal

to a predetermined amount of ink, e.g., an amount of ink sufficient to render an image onto a recording medium. For example, the optical sensor 230 comprises a photo interrupter including a light-emitting element and a light-receiving element. The optical sensor 230 is coupled to the main controller 200, and electric signals outputted from the light-receiving element is supplied to the main controller 200. The optical path 231 is formed between the light-emitting element and the light-receiving element of the optical sensor 230. The type of the ink cartridge is determined on the output signal, which corresponds to the intensity of received light, of the optical sensor 230 when the signal blocking arrangement 185 or the signal blocking arrangement 195 is inserted into the optical path 231.

**[0092]** The optical sensor 235 is positioned at the inner side of a wall surface 287 which forms the top of the case body 281. The optical sensor 235 is configured to detect whether the signal blocking portion 191 of the signal blocking arrangement 186 is present at a predetermined position, such that whether or not the ink cartridge 10 and 10' is mounted is determined. For example, the optical sensor 235 comprises a photo interrupter comprising a light-emitting element and a light-receiving element. The optical sensor 235 is coupled to the main controller 200, and electric signals outputted from the light-receiving element are supplied to the main controller 200. When light is blocked by the signal blocking portion 191 in the optical path 236 of the optical sensor 235, the intensity of light received by the light-receiving element is substantially instantaneously reduced.

**[0093]** A connecting portion 285 is positioned at the lower portion of the wall surface 286 and is configured to be connected to the ink supply port 91. The connecting portion 285 projects from the wall surface 286 toward the interior of the storage chamber 282. A through hole 288 is formed through the connecting portion 285, and an ink tube 278 is inserted into the through hole 288. The through hole 288 is formed at a position corresponding to the ink supply port 91. A tube is provided on the inner side of the connecting portion 285, and when the ink cartridge 10 is mounted in the case 280, the tube is inserted into the ink supply port 91, such that the ink supply port 91 and the connecting portion 285 are connected to each other.

**[0094]** A contact portion 240 is positioned at the upper portion of the wall surface 286, and a contact portion 241 is positioned at the lower portion of the wall surface 286. When the ink cartridge 10 is inserted into the case 280, the contact portion 240 contacts the distal end of the signal blocking arrangement 186, and the contact portion 241 contacts the distal end of the projecting portion 181.

**[0095]** The lock lever 283 is configured to selectively open and close the opening 284, and to reliably secure the ink cartridge 10 and 10' in the storage chamber 282. The lock lever 283 is supported at one end, so as to be rotatable about an axis 290 at the upper edge of the opening 284. The lock lever 283 comprises an operating por-

tion 293 and a claw 294. The operating portion 293 is positioned at an outer surface 297 of the lock lever 283 adjacent the other end of the lock lever, and the claw 294 is positioned at the other end of the lock lever 283. A groove 299 is formed at the lower edge of the opening 284, and is configured to engage the claw 294.

**[0096]** Referring to Figs. 2(a), 2(b), 8, and 13-15, a process for mounting or inserting the ink cartridge 10 into the case 280 is depicted. When the ink cartridge 10 is inserted into the storage chamber 282 of the case 280, the signal blocking portion 189 of the signal blocking arrangement 185 first enters into the optical path 231 of the optical sensor 230. Then, when the ink cartridge 10 is further inserted into the storage chamber 282, the signal blocking portion 191 of the signal blocking arrangement 186 enters into the optical path 236 of the optical sensor 235. At a time when the signal blocking portion 191 enters into the optical path 236, the signal blocking portion 189 has passed through the optical path 231 of the optical sensor 230, and light emitted from the light-emitting element passes through the space 190 behind the signal blocking portion 189.

**[0097]** When the ink cartridge 10 is inserted to the closed end of the storage chamber 282, the distal end of the signal blocking arrangement 186 contacts the contact portion 240, and the distal end of the projecting portion 181 contacts the contact portion 241. At this time, the cutout 187 has entered into the optical path 231.

**[0098]** When the lock lever 283 is rotated in the direction to close the opening 284, an inner surface 296 of the lock lever 283 contacts the rear wall of the cover member 22 and presses the ink cartridge 10 in the direction of insertion. At this time, the coil springs 23 and 24 are compressed. Accordingly, the main body 20 moves in the direction of insertion in a state in which the movable member 21 is stationary and the main body 20 moves toward the movable member 21.

**[0099]** When the main body 20 is further moved in the direction of insertion, the ink supply port 91 is connected to the connecting portion 285, and the translucent portion 140 enters into the cutout 187 and into the optical path 231 of the optical sensor 230.

**[0100]** When the lock lever 283 is completely closed, and the claw 294 engages with the groove 299, the lock lever 283 is locked with respect to the opening 284, and the opening 284 is closed by the lock lever 283. At this time, the main body 20 of the ink cartridge 10 receives an urging force of the coil springs 23 and 24, and the rear wall of the cover member 22 is pressed against the inner surface 296 of the lock lever 283.

**[0101]** Referring to Fig. 16, the main controller 200 controls the operation of the recording apparatus 250. The main controller 200 is a micro computer comprising a central processing unit (CPU) 201, a read only memory (ROM) 202, a random access memory (RAM) 203, an electrically erasable programmable read only memory (EEPROM) 204, and an application specific integrated circuit (ASIC) 205.

**[0102]** The ROM 202 stores a program used by the CPU 201 for controlling the respective operations of the recording apparatus 250, and a program for discriminating the type of the ink cartridge 10 and 10'. The RAM 203 is a storage area or a work area for temporarily storing the respective data used by the CPU 201 for executing the programs. The EEPROM 204 stores settings, flags, or the like to be retained, even after the power is turned off.

**[0103]** Referring to Figs. 1 and 16, the head control board 270, the optical sensor 230, and the optical sensor 235 are coupled to the ASIC 205. A drive circuit (not shown) for driving the respective rollers of the paper feeding apparatus 252 and the transferring apparatus 253, an input unit for entering printing instruction or the like to the recording apparatus 250, and a display device for displaying information relating the recording apparatus 250, are also connected to the ASIC 205.

**[0104]** The head control board 270 controls the recording head 272 based on the signals, e.g., control signal and image signal, supplied from the ASIC 205. Accordingly, the ink is selectively discharged at a predetermined timing from the nozzle 274 of the recording head 272.

**[0105]** The optical sensor 230 outputs sensor signals based on the intensity of light received by the light-receiving element. For example, analog electric signals, such as voltage signals or current signals, are outputted from the optical sensor 230 based on the intensity of light received by the light-receiving element. The sensor signal outputted from the optical sensor 230 is supplied to the main controller 200, and the main controller 200 determines that the sensor signal is a HIGH level signal when the electrical level, e.g., voltage value or current value, of the sensor signal is greater than or equal to a predetermined threshold value, and determines that the sensor signal is a LOW level signal when the electrical level is less than the threshold value. For example, it is determined that the sensor signal is a LOW level signal when the optical path 231 of the optical sensor 230 is blocked, and that the sensor signal is a HIGH level signal when the optical path 231 is not blocked. The intensity of the light received by the light-receiving element may be zero when the light emitted by the light-emitting element is blocked or the path of the light is altered.

**[0106]** The optical sensor 235 functions in substantially the same way as the optical sensor 230, and outputs sensor signals based on the intensity of light received by the light-receiving element.

**[0107]** Referring to Figs. 17(a) and 17(b), exemplary time profiles of signal levels of the sensor signals outputted from the optical sensor 230 and the optical sensor 235 during the mounting of the ink cartridge 10 are depicted, and referring to Figs. 17(c) and 17(c), exemplary time profiles of signal levels of the sensor signals outputted from the optical sensor 230 and the optical sensor 235 during the mounting of the ink cartridge 10' are depicted.

**[0108]** As shown in Figs. 17(a) and 17(c), the time pro-

file of the signal level of the sensor signal outputted from the optical sensor 235 when the ink cartridge 10 is mounted to the case 280 is the same as the time profile of the signal level of the sensor signal outputted from the optical sensor 235 when the ink cartridge 10' is mounted to the case 280. Specifically, when the signal blocking portion 191 enters into the optical path 236 of the optical sensor 235 alters the path of the light, the signal level changes from HIGH to LOW at the time T1. In the main controller 200, this change of the signal level from HIGH to LOW is used as a trigger signal in a process for determining the type of the ink cartridge.

**[0109]** Referring to Fig. 17(b), when the ink cartridge 10 is mounted to the case 280, the signal blocking portion 189 enters into the optical path 231 and blocks or alters the path of the light at a time T0. At this time, the signal level of the sensor signal outputted from the optical sensor 230 changes from HIGH to LOW. Because the signal blocking portion 189 is a flat plate, the duration in which the light is blocked or its path is altered is relatively short. The signal blocking portion 189 passes through the optical path 231 and the space 190 enters the optical path after the time T0 and before the time T1. Therefore, at the time T1, the signal level of the optical sensor 230 has been restored from LOW to HIGH.

**[0110]** Subsequently, when the ink cartridge 10 is further inserted, the cutout 187 enters the optical path 231, and when the ink cartridge 10 is completely mounted to the case 280, the translucent portion 140 enters the optical path 231 via the cutout 187 between a time T2 and a time T3. In this state, the position of the signal blocking portion 72 is detected. In Fig. 17(b), the signal level when the signal blocking portion 72 is in the optical path 231 is represented by a solid line (LOW level), and the signal level when the signal blocking portion 72 is out of the optical path 231 is represented by a broken line (HIGH level).

**[0111]** Referring to Fig. 17(d), when the ink cartridge 10' is mounted to the case 280, the signal blocking portion 199 also enters the optical path 231 to block the light or alter the path of the light at the time T0. At this time, the signal level of the sensor signal outputted from the optical sensor 230 changes from HIGH to LOW. Because the signal blocking portion 199 has the side walls 198, the duration during which the light is blocked or altered by the signal blocking portion 199 is greater than the duration during which the light is blocked or altered by the signal blocking portion 189. Specifically, at the time T1, the side walls 198 are still in the optical path 231. Therefore, at the time T1, the signal level of the sensor signal outputted from the optical sensor 230 is maintained in the LOW state.

**[0112]** Subsequently, when the ink cartridge 10' is further inserted, at the time T2, the side walls 198 pass through the optical path 231, and the cutout 187 enters the optical path 231. At this time, the signal level of the optical sensor 230 is restored from LOW to HIGH. Then, when the ink cartridge 10' is completely mounted to the

case 280, the translucent portion 140 enters the optical path 231 via the cutout 187 at a time between time T2 and Time T3. In this state, the position of the signal blocking portion 72 may be detected. In Fig. 17(d), the signal level when the signal blocking portion 72 is in the optical path 231 is represented by a solid line (LOW level), and the signal level when the signal blocking portion 72 is out of the optical path 231 is represented by a broken line (HIGH level).

**[0113]** The type of the ink cartridge is determined by the main controller 200 based on the time profiles of the optical sensor 230 and the optical sensor 235.

**[0114]** Referring to Fig. 18, a procedure for determining whether the mounted ink cartridge is the ink cartridge 10 or the ink cartridge 10' is depicted. In Step S1, the main controller 200 determines whether the signal blocking portion 189 or 199 has entered the optical path 231 of the optical sensor 230, e.g., it is determined whether or not the signal level of the sensor signal outputted from the optical sensor 230 has changed from HIGH to LOW. When the main controller 200 determines that the signal blocking portion 189 or 199 has entered the optical path 231, Step S2 is performed. Step S2 is not performed until the main controller 200 determines that the signal blocking portion 189 or 199 has entered the optical path 231.

**[0115]** In the Step S2, the main controller 200 determines whether the signal blocking portion 191 has entered the optical path 236, e.g., it is determined whether the signal level of the optical sensor 235 has changed from HIGH to LOW, which corresponds to a detection of a trigger signal. When the trigger signal is detected in Step S2, in Step S3, the main controller 200 determines whether the signal level of the sensor signal outputted from the optical sensor 230 at the time T1 when the trigger signal is detected is HIGH or LOW. For example, when the signal level at the time T1 is HIGH, the main controller 200 determines that the ink cartridge 10 is inserted in the case 280, and when the signal level at the time T1 is LOW, the main controller determines that the ink cartridge 10' is inserted in the case 280.

**[0116]** When it is determined that the signal level of the sensor signal outputted from the optical sensor 230 is HIGH in Step S3, a bit flag indicating that the installed ink cartridge corresponds to the ink cartridge 10 is set to a register, e.g., a register of the CPU 201 in Step S4. If a bit flag indicating that the installed ink cartridge corresponds to the ink cartridge 10' has been set previously, the bit flag indicating that the installed ink cartridge corresponds to the ink cartridge 10' is cleared, and the bit flag indicating that the installed ink cartridge corresponds to the ink cartridge 10 is set. On the other hand, when it is determined that the signal level of the sensor signal outputted from the optical sensor 230 is LOW, the bit flag indicating that the installed ink cartridge corresponds to the ink cartridge 10' is set to the register in Step S5. If the bit flag indicating that the installed ink cartridge corresponds to the ink cartridge 10 has been set previously, the bit flag indicating that the installed ink cartridge cor-

responds to the ink cartridge 10 is cleared, and the bit flag indicating that the installed ink cartridge corresponds to the ink cartridge 10' is set. If the bit flag is set, the recording apparatus 250 or an information processing apparatus e.g. a personal computer connected to the recording apparatus 250, displays which of the ink cartridges 10 and 10' is inserted, based on the flag.

**[0117]** If signal level of the optical sensor 235 changes from Low to High, the determination process may start again. Moreover, the determination process may be executed when the lock lever 283 is opened, and the determination process may conclude when the lock lever 283 is closed.

**[0118]** The type of the ink cartridge 10 and 10' is determined based on the signal level of the sensor signal outputted from the optical sensor 230 at the time T1 when the trigger signal is detected. Therefore, the configuration of the ink cartridge 10 and 10' allows the recording apparatus 250 to accurately determine the type of the ink cartridge 10 or 10' independent of the speed with which the user mounts the ink cartridge 10 or 10' to the printer and regardless of whether the user begins to insert the ink cartridge into the printer and then partially removes the ink cartridge before finally fully inserting the ink cartridge into the printer.

**[0119]** The above described process is configured to discriminate between the two types of the ink cartridges 10 and 10', however, three or more types of ink cartridges may be discriminated. Moreover, an ink cartridge containing black ink and an ink cartridge containing color ink other than the black ink may be discriminated, and an ink cartridge containing pigment ink and an ink cartridge containing dye ink also may be discriminated.

**[0120]** Referring to Fig. 19, a packaging arrangement 230, according to an embodiment of the present invention, is depicted. The packaging arrangement 230 comprises an ink cartridge, e.g., the ink cartridge 10 (or 10'), and a packaging member 231. The ink cartridge 10 is accommodated in an interior of the packaging member 231. The ink cartridge 10 is shipped and sold in the packaging arrangement 230.

**[0121]** The interior of the ink chamber 100 is depressurized to a pressure less than the atmospheric pressure by, for example, a vacuum pump to reduce an amount of air dissolved in the ink in the ink chamber 100. The interior of the packaging member 231 is also depressurized to a pressure less than the atmospheric pressure by, for example, a vacuum pump to prevent air from entering into the ink chamber 100 through the films covering the side faces 45 and 46.

**[0122]** The packaging member 231 is liquid-proof but has some gas permeability. Therefore, air may enter the interior of the packaging member 231 when the packaging arrangement 230 is left unused for an extended period of time. Nevertheless, if a depressurized space exists in the interior of the packaging member 231, the interior of the packaging member 231 is maintained at a stable depressurized state for an extended period of time.

**[0123]** The packaging arrangement 230 is manufactured as follows. The ink cartridge 10 is accommodated in the interior of the packaging member 231 in a state in which the movable member 21 is held at the first (extended) position shown in Fig. 2(b). While maintaining this state, the pressure in the interior of the packaging member 231 is reduced to a pressure which is less than the atmospheric pressure, and the packaging member 231 is sealed. Because the ink cartridge 10 is accommodated in the packaging member 231 in this manner, the depressurized space of a predetermined capacity is formed between the front face 41 of the main body 20 and the front wall 161 of the movable member 21 in the interior of the packaging member 231. Therefore, the interior of the packaging member 231 is maintained as the depressurized state for an extended period of time.

**[0124]** Nevertheless, if the interior of the packaging member 231 is depressurized too much, a pressure difference between the atmospheric pressure and the pressure in the interior of the packaging member 231 may become so great that a relatively large force acts on the ink cartridge 10. In this case, if the depressurized space is formed between the front face 41 of the main body 20 and the front wall 161 of the movable member 21, the movable member 21 may deform inward and may not be restored to an original shape. Therefore, in another embodiment of the present invention, the ink cartridge 10' may be accommodated in the packaging member 231 in a state in which the movable member 21 is held at the second (retracted) position shown in Fig. 2(c). When the movable member 21 is at the second position, the depressurized space between the front face 41 of the main body 20 and the front wall 161 of the movable member 21 is relatively small, and therefore, the deformation of the movable member 21 may be prevented. The size of the packaging arrangement 230 is also reduced. Because the depressurized space still exists even though it is relatively small, the interior of the packaging member 231 is maintained at a stable depressurized state for a reasonable period of time.

**[0125]** Referring to Figs. 20 and 21 a cartridge mounting portion 1276, according to another embodiment of the present invention, is depicted. The cartridge mounting portion 1276 comprises a lock lever 1283 instead of the lock lever 283 of the cartridge mounting portion 276. The lock lever 283 comprises a first portion 1291, a second portion 1292, and a pivot portion 1290 between the first portion 1291 and the second portion 1292. The pivot portion 1290 is supported at the upper portion of the case 280 adjacent to the opening 284 such that the lock lever 1283 pivots about the pivot portion 1290. The first portion 1291 extends from the pivot portion to the outside of the case 280, and the second portion 1292 extends from the pivot portion 1290 to the storage chamber 282. The first portion 1291 is positioned above the second portion 1292 because the weight of the first portion 1291 is less than the weight of the second portion 1292. As shown in Fig. 20, when the ink cartridge 10 is installed in the cartridge

mounting portion 1276, a portion of the second portion 1292 contacts a portion of the latching recess 1000. The main body 20 of the ink cartridge 10 receives the urging force of the coil springs 23 and 24 toward the opening 284. Nevertheless, because the portion of the second portion 1292 contacts the portion of the latching recess 1000 to retain the main body 20 in the case 280 against the urging force of the coil springs 23 and 24, the ink cartridge 10 remains in the case 280.

**[0126]** When a user intends to remove the ink cartridge 10 from the cartridge mounting portion 1276, the user applies a downward force to an end portion of the first portion 1291. The lock lever 1283 then pivots about the pivot portion 1290, as shown in Fig. 21, and the second portion 1292 moves up and separates from the latching recess 1000. Consequently, the coil springs 23 and 24 expand, and the ink cartridge 10 is partially ejected from the cartridge mounting portion 1276. The user then grasps the rear portion of the ink cartridge 10 and removes the ink cartridge 10 from the cartridge mounting portion 1276. Thus, the ink cartridge is readily removed from the cartridge mounting portion 1276. Moreover, because the ink cartridge 10 is not configured to retain the movable member 21 in the second position by itself, the movable member 21 moves freely from the second position to the first position when the second portion 1292 separates from the latching recess 1000, and thereby the ink cartridge 10 is partially ejected from the cartridge mounting portion 1276.

**[0127]** Referring to Figs. 22(a) and 22(b), a distance D1 between the centre lines of the signal blocking portion 191 and the signal blocking portion 189 of the ink cartridge 10 or between the signal blocking portion 191 and the signal blocking portion 199 of the ink cartridge 10' in the height direction as indicated by the arrow 32 is 32 millimeters to 35 millimeters. A distance D2 between a front end of the signal blocking portion 191 and a front end of the signal blocking portion 189 of the ink cartridge 10 or between a front end of the signal blocking portion 191 and a front end of the signal blocking portion 199 of the ink cartridge 10' in the depth direction as indicated by the arrow 33 is -4.7 millimeters to 7.6 millimeters. In other words, the front end of the signal blocking portion 191 is positioned 7.6 millimeters or less forward from the front end of the signal blocking portion 189 or 199 in the depth direction, or the front end of the signal blocking portion 191 is positioned 4.7 millimeters or less rearward from the front end of the signal blocking portion 189 or 199 in the depth direction.

**[0128]** While the invention has been described in connection with exemplary embodiments, it will be understood by those skilled in the art that other variations and modifications of the exemplary embodiments described above may be made without departing from the scope of the invention. Other embodiments will be apparent to those skilled in the art from a consideration of the specification or practice of the invention disclosed herein. It is intended that the specification and the described ex-

amples are considered merely as exemplary of the invention, with the true scope of the invention being indicated by the flowing claims.

**[0129]** It has to be understood that the term "signal blocking" as used herein is meant to include not only reduction of the signal intensity to zero, but also to a reduced level sufficiently lower for the signal blocking portion to be detected. In this respect, although it is preferable that the 100% intensity signal is prevented from passing through the signal blocking portion, also a reduced intensity is allowed to pass and the intensity drop detected.

## Claims

### 1. An ink cartridge (10,10'), comprising:

an ink chamber (100) configured to store ink;  
 a first signal blocking portion;  
 a second signal blocking portion; and  
 a third signal blocking portion, wherein  
 the first signal blocking portion is configured to either prevent a first signal from passing there through or to alter a path of the first signal when the first signal blocking portion receives the first signal,  
 the second signal blocking portion is configured to either prevent a second signal from passing there through or to alter a path of the second signal when the second signal blocking portion receives the second signal, and to provide information as to the color of ink stored in the ink chamber (100), and  
 the third signal blocking portion is configured to either prevent the second signal from passing there through or to alter a path of the second signal when the third signal blocking portion receives the second signal.

2. The ink cartridge of claim 1 having a width in a width direction, a height in a height direction and a depth in a depth direction, wherein each of the height and the depth is greater than the width, a distance between the first signal blocking portion and the second signal blocking portion is 32 millimeters to 35 millimeters in the height direction, and/or the first signal blocking portion is positioned 7.6 millimeters or less forward from the second signal blocking portion in the depth direction, or the first signal blocking portion is positioned 4.7 millimeters or less rearward from the second signal blocking portion in the depth direction.

3. The ink cartridge of claims 1 or 2, wherein the third signal blocking portion is configured to move with respect to each of the first signal blocking portion and the second signal blocking portion.

4. The ink cartridge of any one of claims 1 to 3, wherein the first signal blocking portion and the second signal blocking portion are configured to move with respect to the third signal blocking portion.

5. The ink cartridge of claim 4, further comprising a case (20) having at least a portion of the ink chamber (100) defined therein, wherein the third signal blocking portion is positioned within the case (20) and is configured to move based on an amount of ink in the ink chamber (100).

6. The ink cartridge of claim 4, further comprising:

a case (20) having at least a portion of the ink chamber (100) defined therein, wherein the third signal blocking portion is positioned within the case (20);  
 a movable member (21) configured to move relative to the case (20), wherein the movable member (21) comprises the first signal blocking portion and the second signal blocking portion; and  
 at least one resilient member having a first end which is coupled to the case and a second end which is coupled to the movable member (21).

7. The ink cartridge of one of claims 1 to 6, wherein the first signal blocking portion is configured to permanently prevent the first signal from passing there through or to permanently alter a path of the first signal in an inserted state of the cartridge.

8. The ink cartridge according to one of claims 1 to 7, further comprising a front wall (161), wherein the second signal blocking portion (189, 199) is located at the center of the front wall (161).

9. The ink cartridge according to one of claims 1 to 8 which is configured to be inserted into a recording apparatus (250) in a direction of insertion (30), wherein the ink cartridge has a width in a width direction (31), a height in a height direction (32), a depth in a depth direction (33), and a distance (D1) between the first signal blocking portion and the second signal blocking portion in the height direction, and wherein the depth direction (33) is parallel with the direction of insertion (30).

10. The ink cartridge according to any one of claims 1 to 9, wherein the second signal blocking portion is configured to provide information as to the color of ink stored in the ink chamber (100) by blocking the second signal such that the duration of time during which the second signal is prevented from passing there through or the path of the second signal is altered changes depending on the color of ink.



11. The ink cartridge according to claim 10, wherein the thickness of the second signal blocking portion in a direction of insertion (30) is determinative of the duration of time.

12. A set of ink cartridges, comprising first and second ink cartridges according to any one of claims 1 to 11, wherein:

the second signal blocking portion of the first ink cartridge has a thickness configured to prevent the second signal from passing there through or alter the path of the second signal at a time that the first signal blocking portion initially prevents the first signal from passing there through or alters the path of the first signal; and the second signal blocking portion of the second ink cartridge has a thickness configured not to prevent the second signal from passing there through or alter the path of the second signal at the time that the first signal blocking portion initially prevents the first signal from passing there through or alters the path of the first signal.

13. A set of ink cartridges (10,10'), comprising first and second ink cartridges (10,10') according to any one of claims 1 to 11, wherein:

the first ink cartridge (10') has black ink stored in ink chamber (100); and the second ink cartridge (10) has color ink other than the black ink, stored in the ink chamber (100).

14. An ink cartridge determination system, comprising; the ink cartridge according to any one of claims 1-11 or the set of ink cartridges according to claim 12 or 13; and a recording apparatus (250) comprising:

a cartridge mounting portion (276,1276) configured to mount the ink cartridge; a first sensor disposed in the cartridge mounting portion (276,1276) and comprising a first signal-emitting element configured to emit the first signal and a first signal-receiving element configured to receive the first signal, wherein the first signal blocking portion is configured to either prevent the first signal from passing there through or to alter the path of the first signal at least during a mounting of the ink cartridge (10,10') to the cartridge mounting portion (276,1276), wherein an intensity of the first signal received by the first signal-receiving element when the first signal is prevented from passing through the first signal blocking portion or the path of the first signal is altered by the first signal blocking portion is different from an intensity of the first signal received by the first signal-receiv-

ing element when the first signal is not prevented from passing through the first signal blocking portion or the path of the first signal is not altered by the first signal blocking portion;

a second sensor disposed in the cartridge mounting portion (276,1276) and comprising a second signal-emitting element configured to emit the second signal and a second signal-receiving element configured to receive the second signal, wherein the second signal blocking portion is configured to either prevent the second signal from passing there through or to alter the path of the second signal during the mounting of the ink cartridge (10,10') to the cartridge mounting portion (276,1276), and the third signal blocking portion is configured to either prevent the second signal from passing there through or to alter the path of the second signal when the mounting of the ink cartridge (10,10') to the cartridge mounting portion is completed, wherein an intensity of the second signal received by the second signal-receiving element when the second signal is prevented from passing through the second signal blocking portion or the third signal blocking portion or the path of the second signal is altered by the second signal blocking portion or the third signal blocking portion is different from an intensity of the second signal received by the second signal-receiving element when the second signal is not prevented from passing through the second signal blocking portion or the third signal blocking portion or the path of the second signal is not altered by the second signal blocking portion or the third signal blocking portion; and a determiner configured to determine information associated with the ink cartridge (10,10') based on the intensity of the second signal received by the second signal-receiving element at a time that the intensity of the first signal received by the first signal-receiving element initially changes during the mounting of the ink cartridge (10,10') to the cartridge mounting portion (276,1276).

15. The ink cartridge determination system according to claim 14, wherein the determiner is further configured to determine an amount of ink in the ink chamber (100) based on the intensity of the second signal received by the second signal-receiving element when the mounting of the ink cartridge (10,10') to the cartridge mounting portion (276,1276) is completed.

16. Use of an ink cartridge (10, 10') according to any of claims 1-13 so that either a first signal is prevented from passing through the first signal blocking portion (191) or a path of the first signal is altered when the

first signal blocking portion (191) receives the first signal, by the first signal blocking portion (191), that either a second signal is prevented from passing through the second signal blocking portion (189, 199) or a path of the second signal is altered when the second signal blocking portion (189, 199) receives the second signal, by the second signal blocking portion (189, 199), and that either the second signal is prevented from passing through the third signal blocking portion (72) or the path of the second signal is altered when the third signal blocking portion (72) receives the second signal, by the third signal blocking portion (72).

17. Use of the ink cartridge (10, 10') according to claim 16 so that either the first signal is prevented from passing through the first signal blocking portion (191) or the path of the first signal is altered when the first signal blocking portion (191) receives the first signal at least during a mounting of the ink cartridge (10, 10') to a recording apparatus (250), by the first signal blocking portion (191), that either the second signal is prevented from passing through the second signal blocking portion (189, 199) or the path of the second signal is altered when the second signal blocking portion (189, 199) receives the second signal during the mounting of the ink cartridge (10, 10') to the recording apparatus (250), by the second signal blocking portion (189, 199), and that either the second signal is prevented from passing through the third signal blocking portion (72) or the path of the second signal is altered when the third signal blocking portion (72) receives the second signal when the mounting of the ink cartridge (10, 10') to the recording apparatus (250) is completed, by the third signal blocking portion (72).
18. Use of the ink cartridge (10') according to claim 16 or 17 so that either the second signal is prevented from passing through the second signal blocking portion (199) or the path of the second signal is altered by the second signal blocking portion (199) at a time that either the first signal is initially prevented from passing through the first signal blocking portion (191) or the path of the first signal is initially altered by the first signal blocking portion (191).
19. Use of the ink cartridge (10) according to claim 16 or 17 so that either the second signal is not prevented from passing through the second signal blocking portion (189) or the path of the second signal is not altered by the second signal blocking portion (189) at a time that either the first signal is initially prevented from passing through the first signal blocking portion (191) or the path of the first signal is initially altered by the first signal blocking portion (191).

20. Use of a first signal blocking portion (191) of an ink cartridge (10, 10') according to any of claims 1-13 so that either a first signal is prevented from passing there through or a path of the first signal is altered when the first signal blocking portion (191) receives the first signal, a second signal blocking portion (189, 199) of the ink cartridge (10, 10') so that either a second signal is prevented from passing there through or a path of the second signal is altered when the second signal blocking portion (189, 199) receives the second signal, and a third signal blocking portion (72) of the ink cartridge (10, 10') so that either the second signal is prevented from passing there through or a path of the second signal is altered when the third signal blocking portion (72) receives the second signal.
21. Use according to claim 20, wherein the second signal blocking portion is used to provide information as to the color of ink stored in the ink chamber (100).

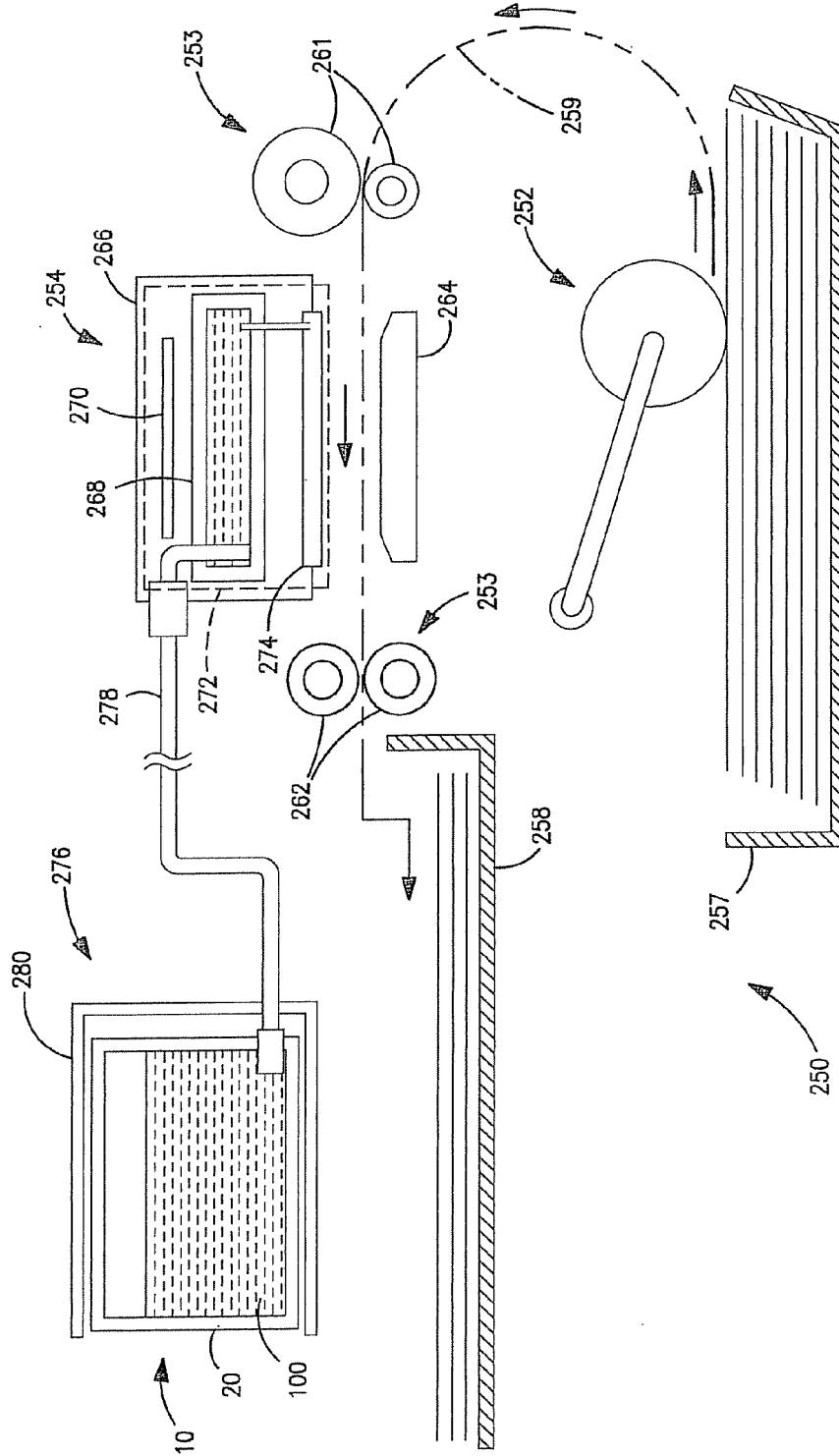

FIG. 1

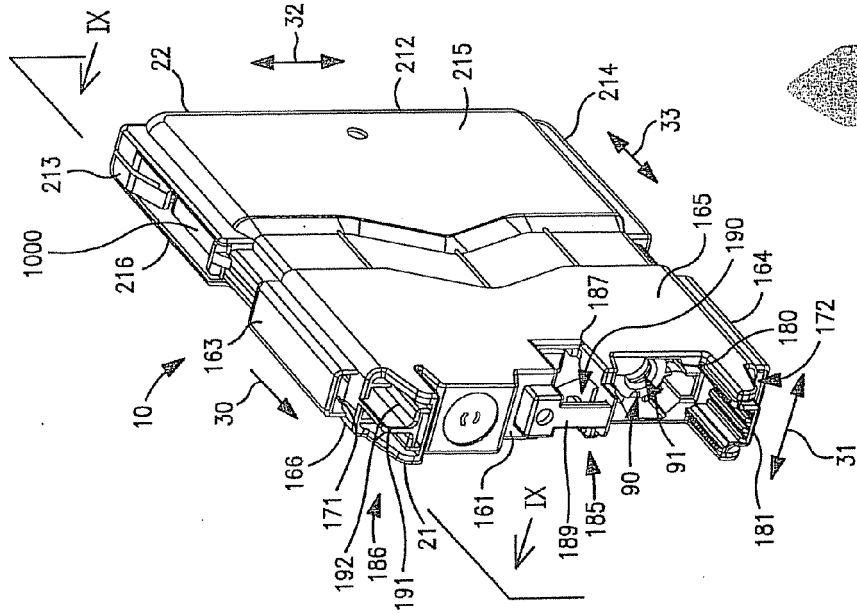

FIG. 2(a)

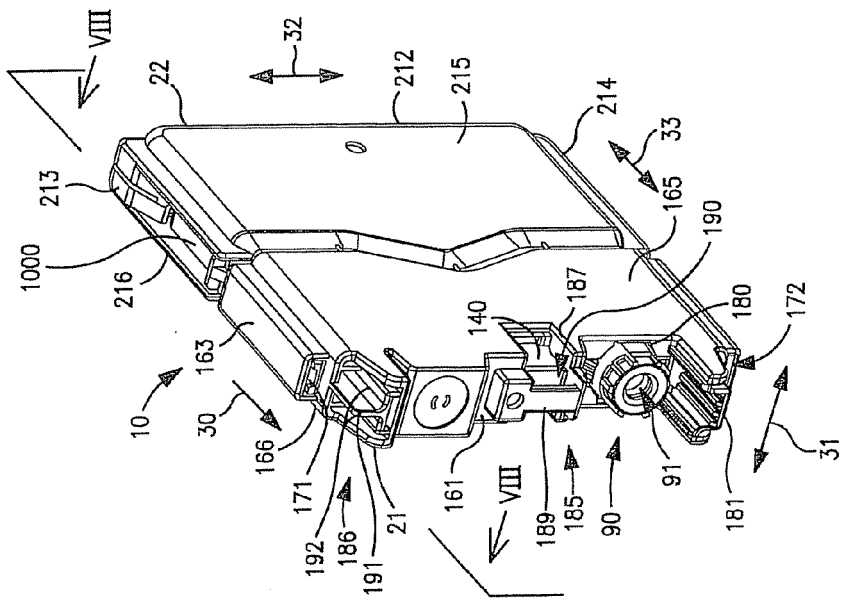

FIG. 2(b)



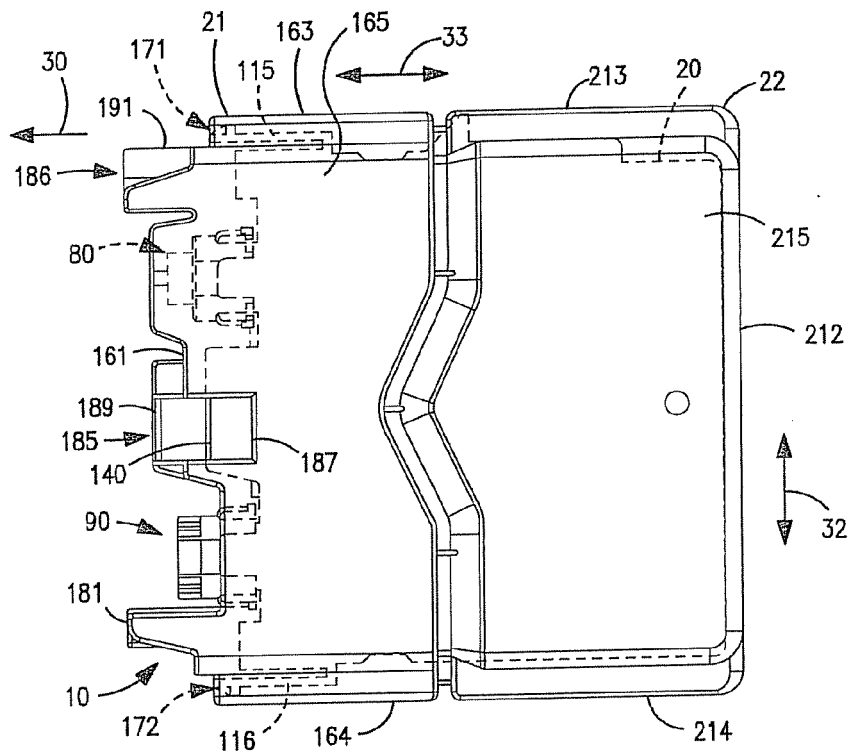

FIG. 3(a)

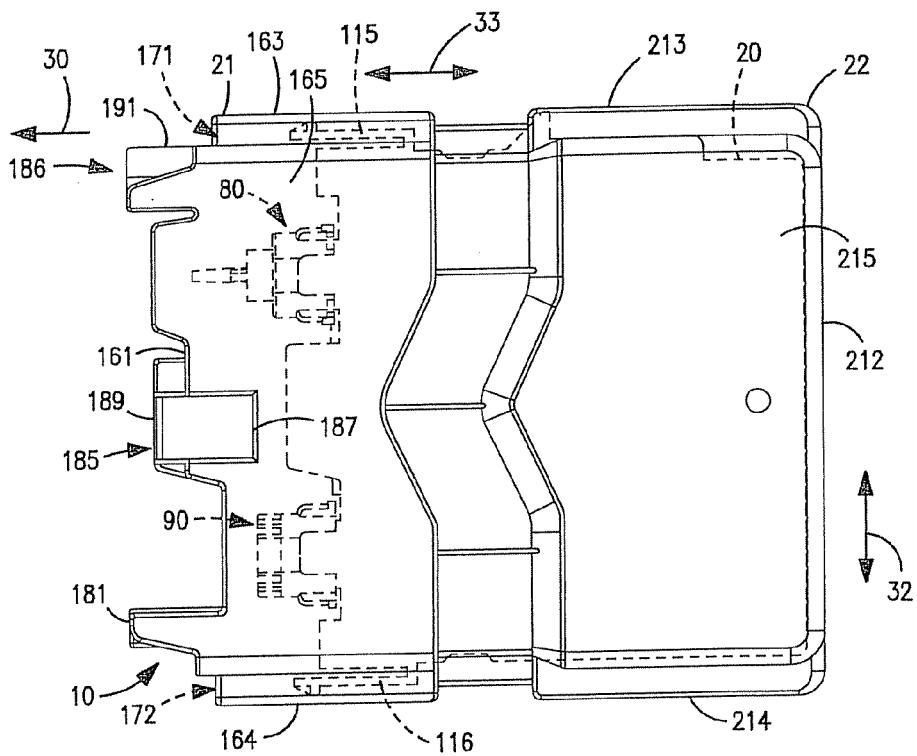

FIG. 3(b)

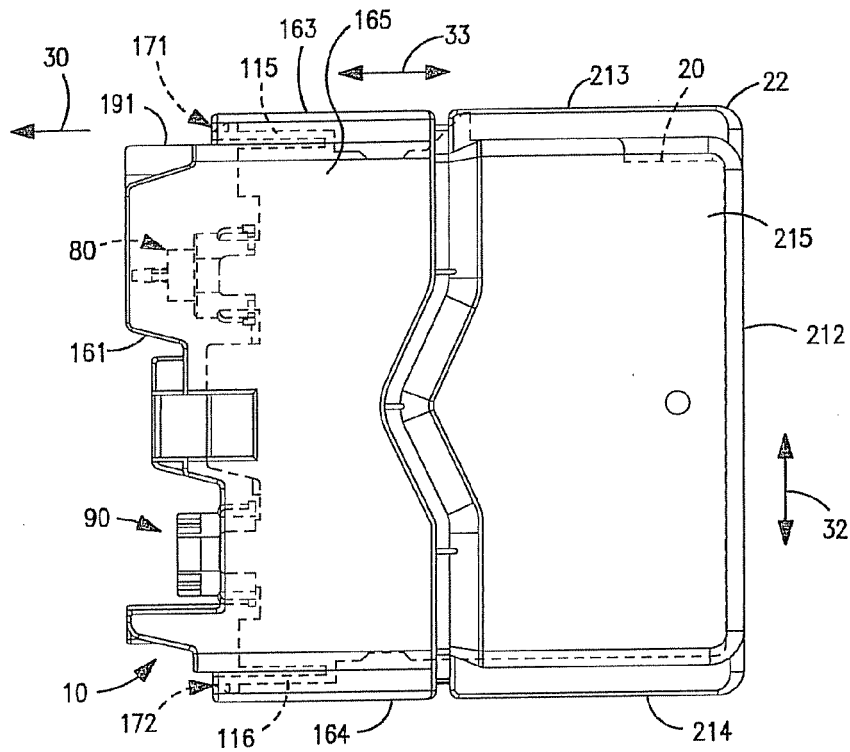

FIG. 3(c)

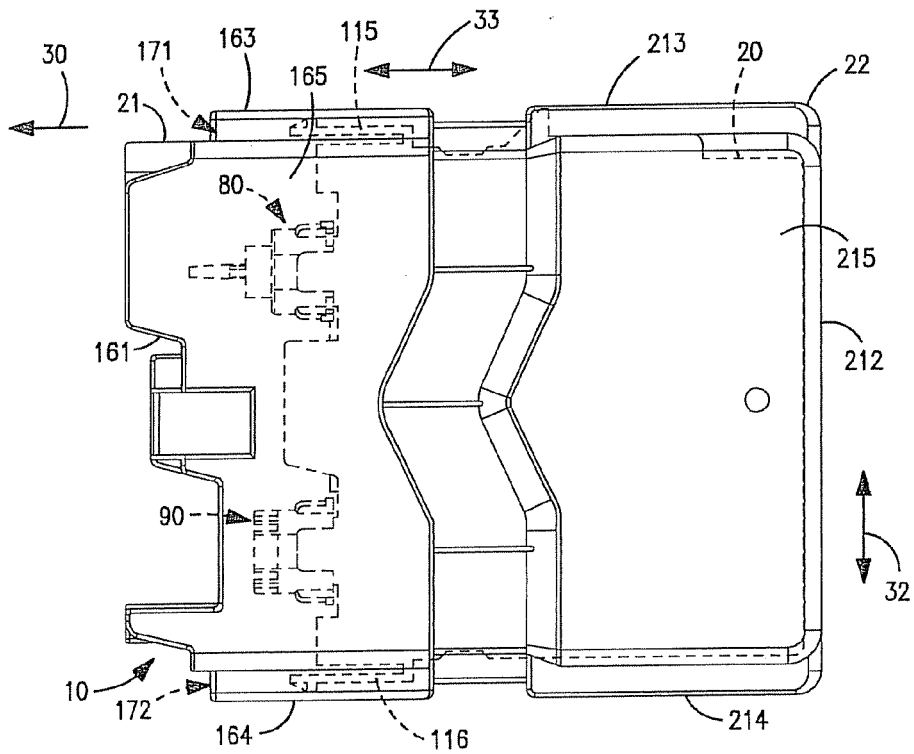

FIG. 3(d)





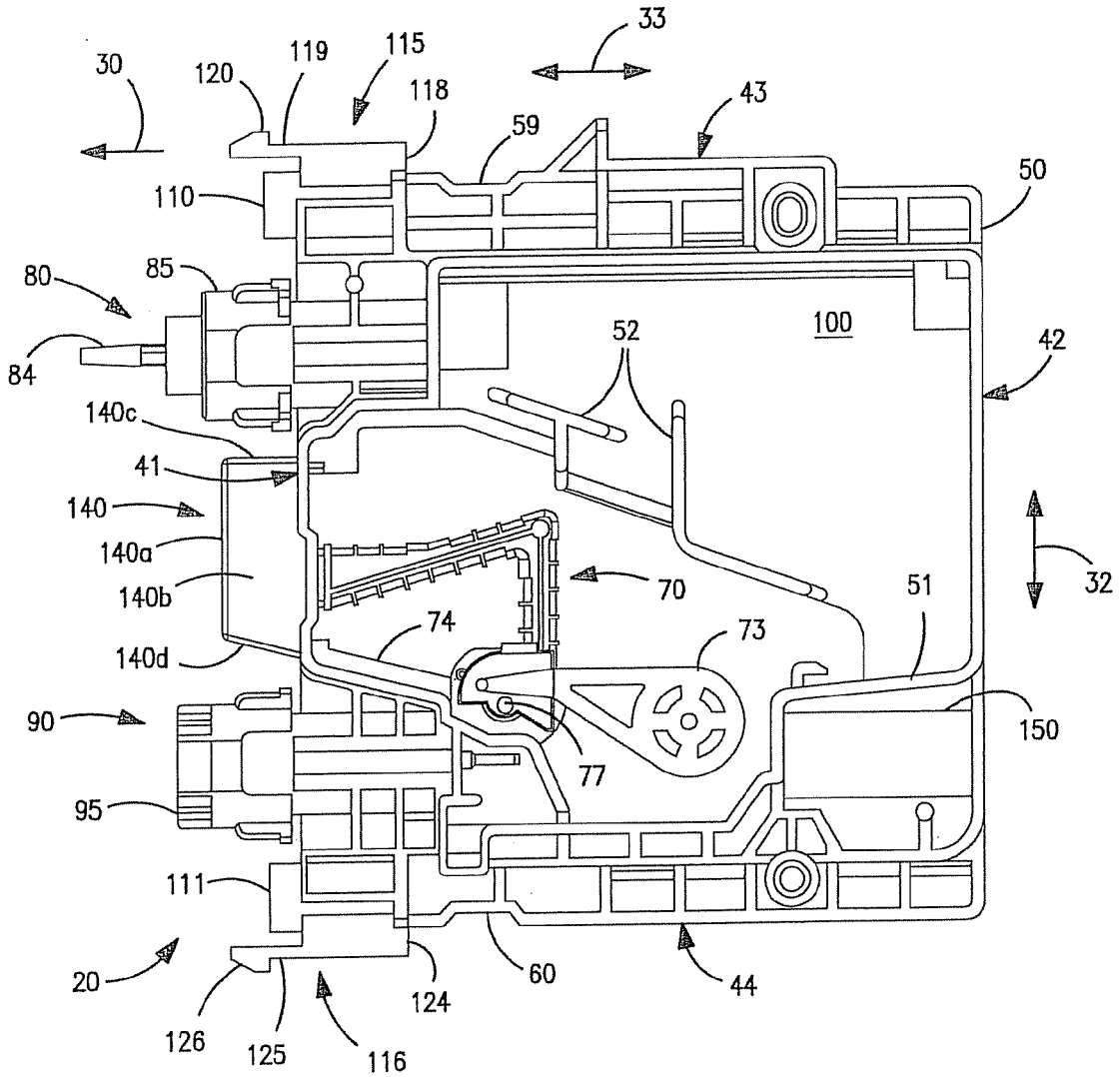

FIG. 5





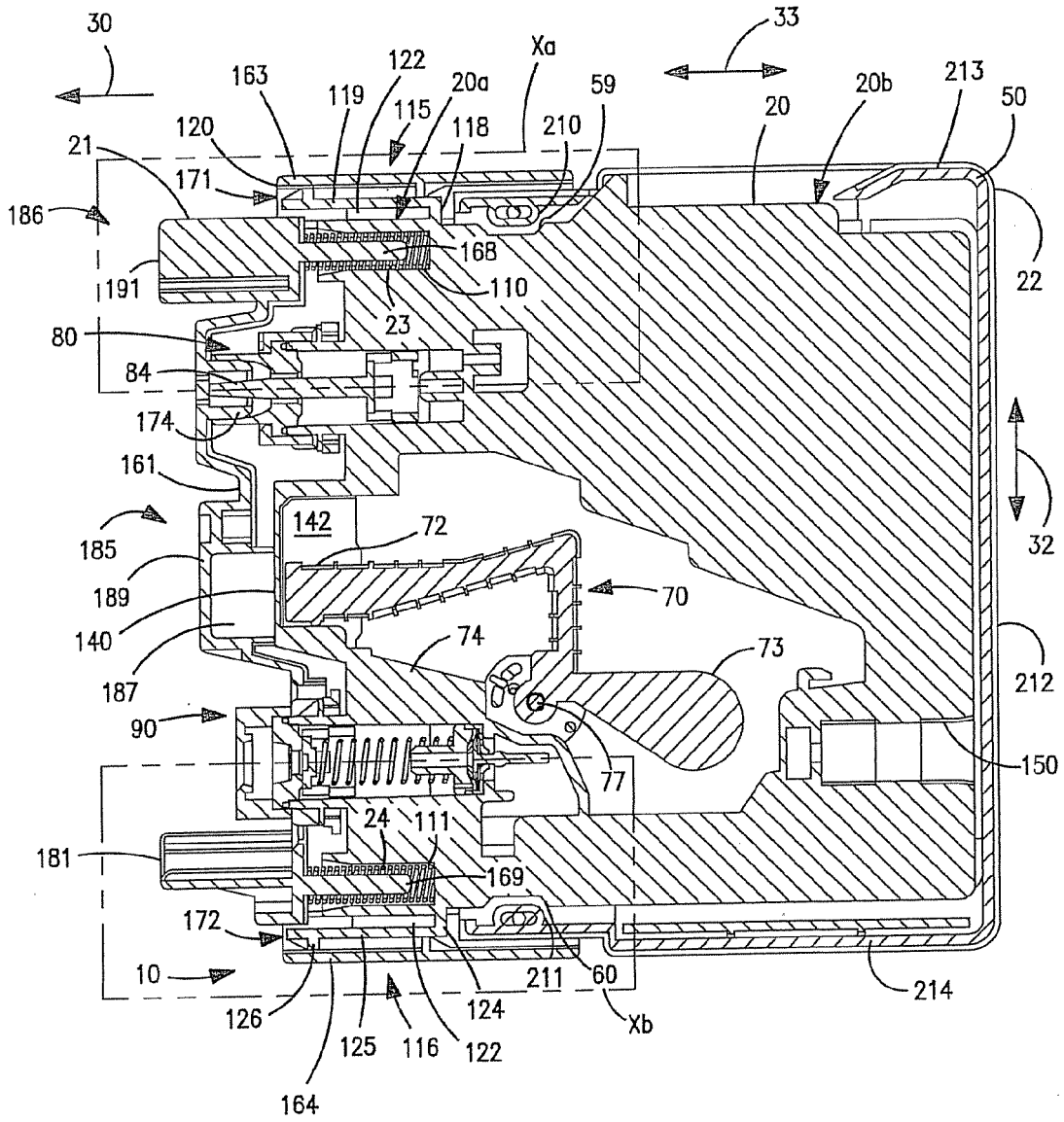

FIG. 8

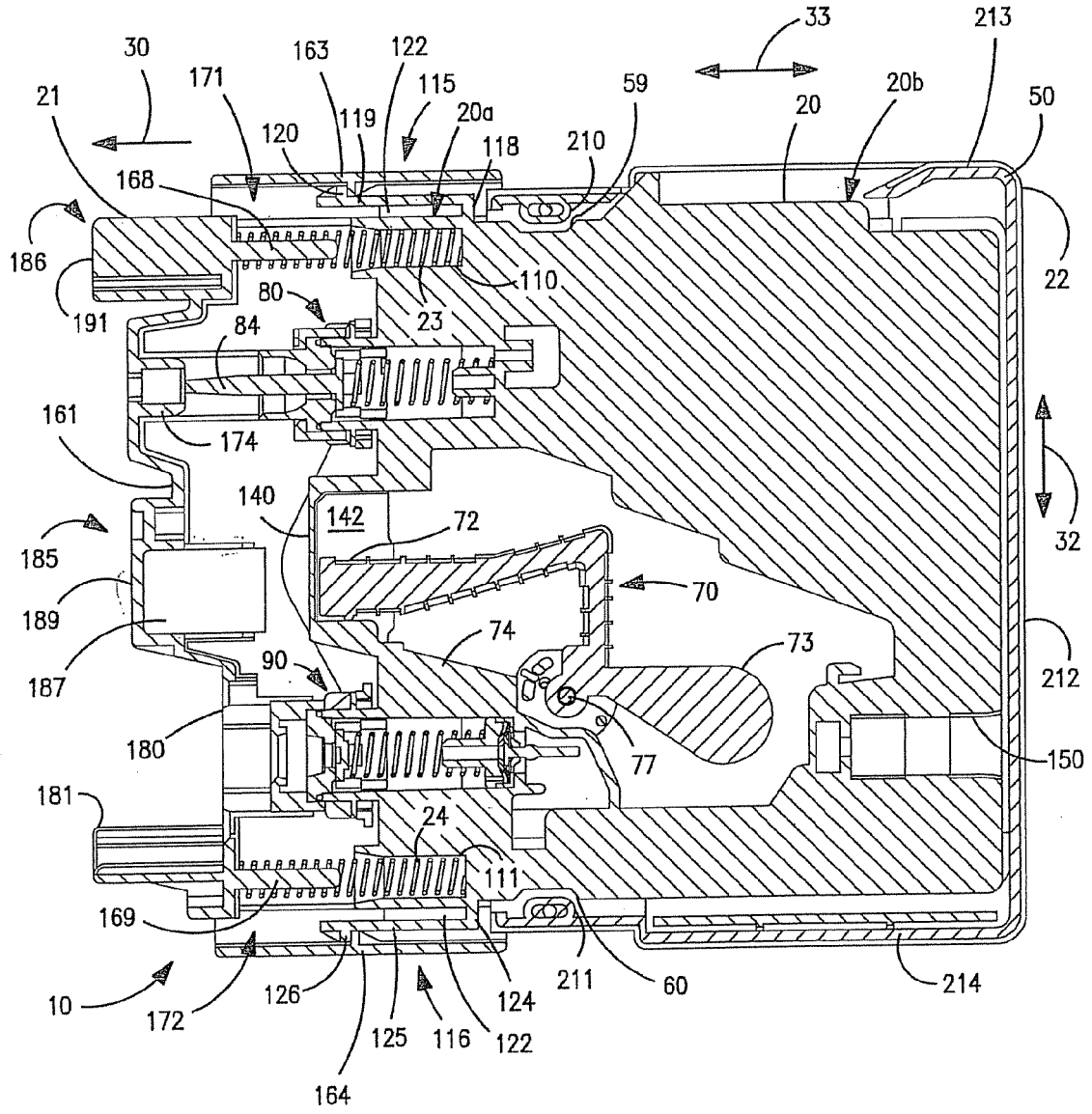

FIG. 9

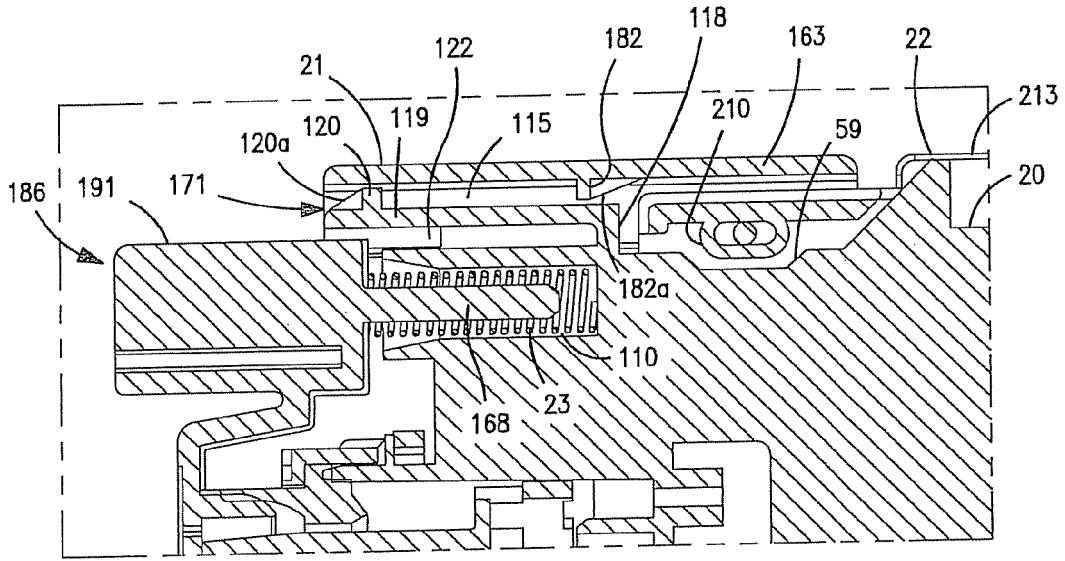

FIG. 10(a)

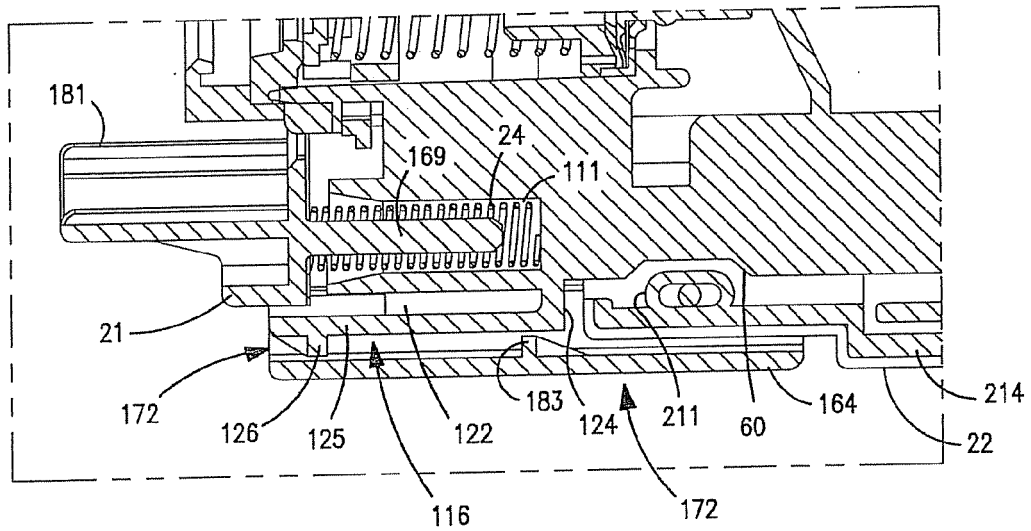

FIG. 10(b)

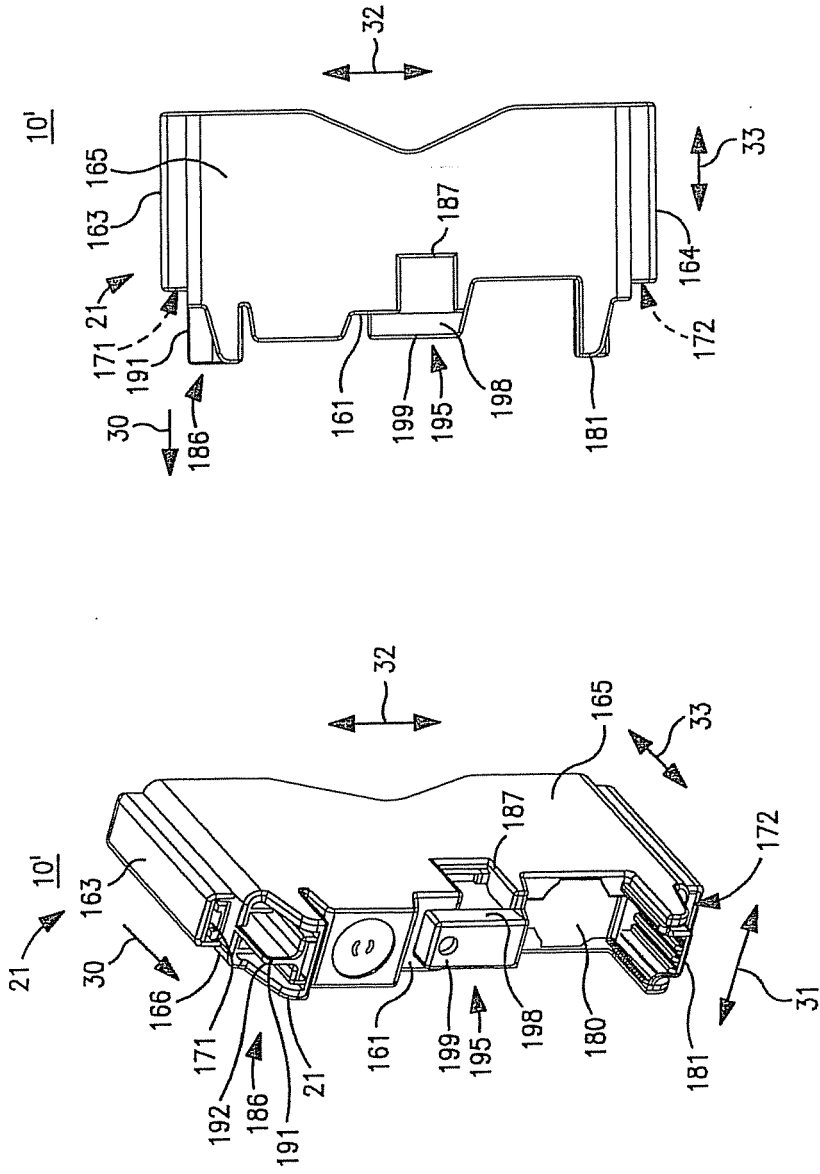

FIG. 11(b)

FIG. 11(a)

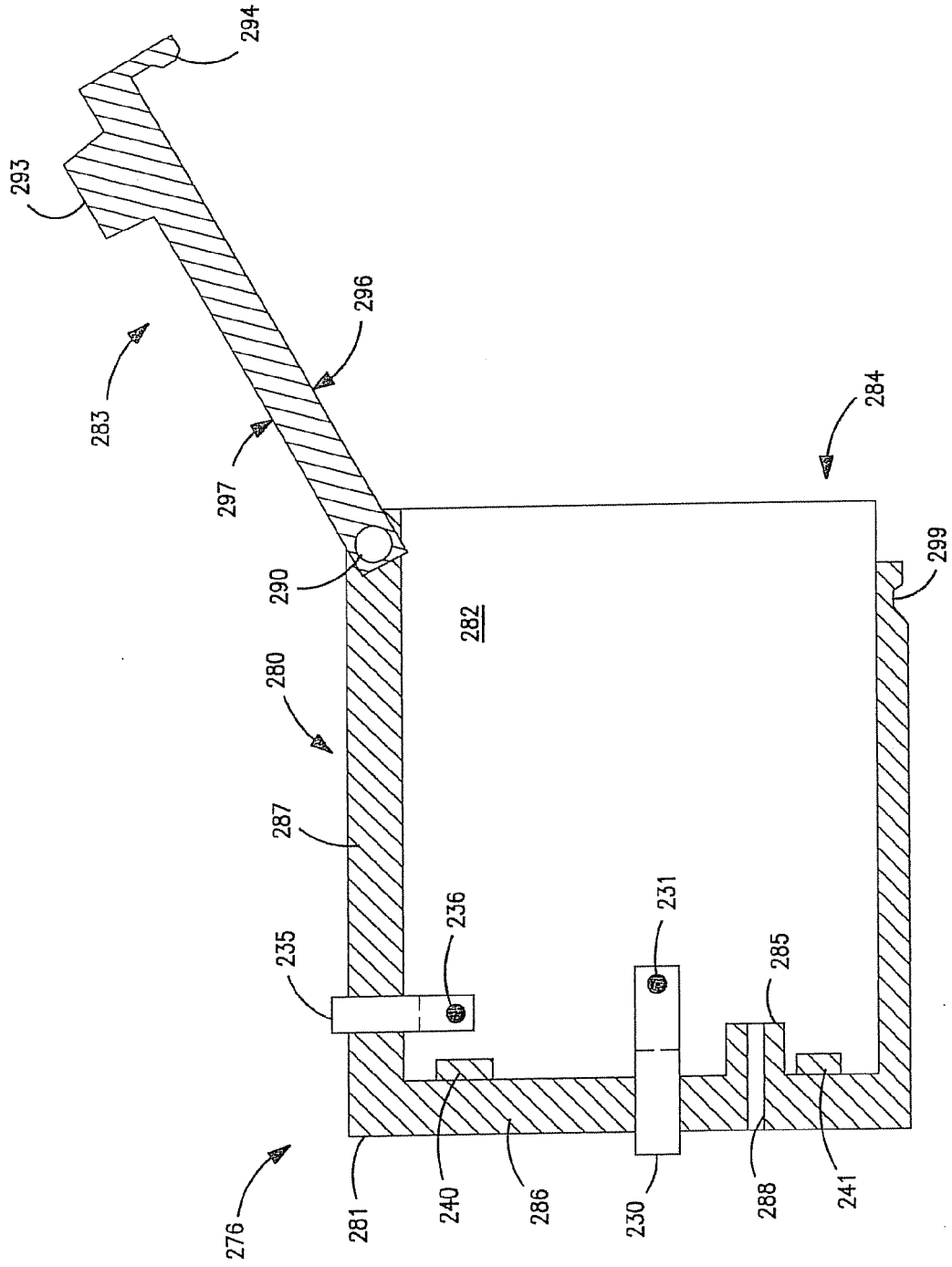

FIG. 12



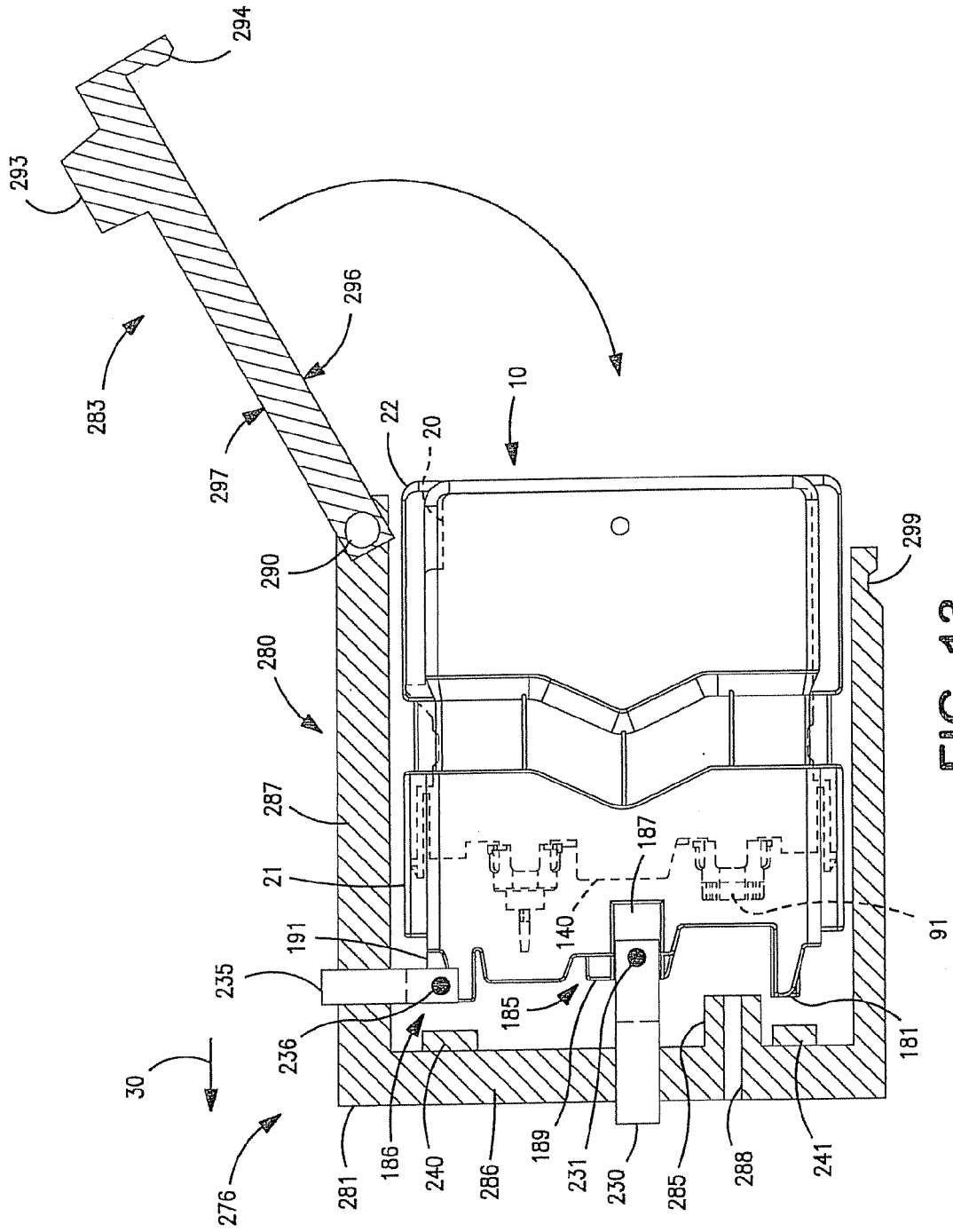

FIG. 13

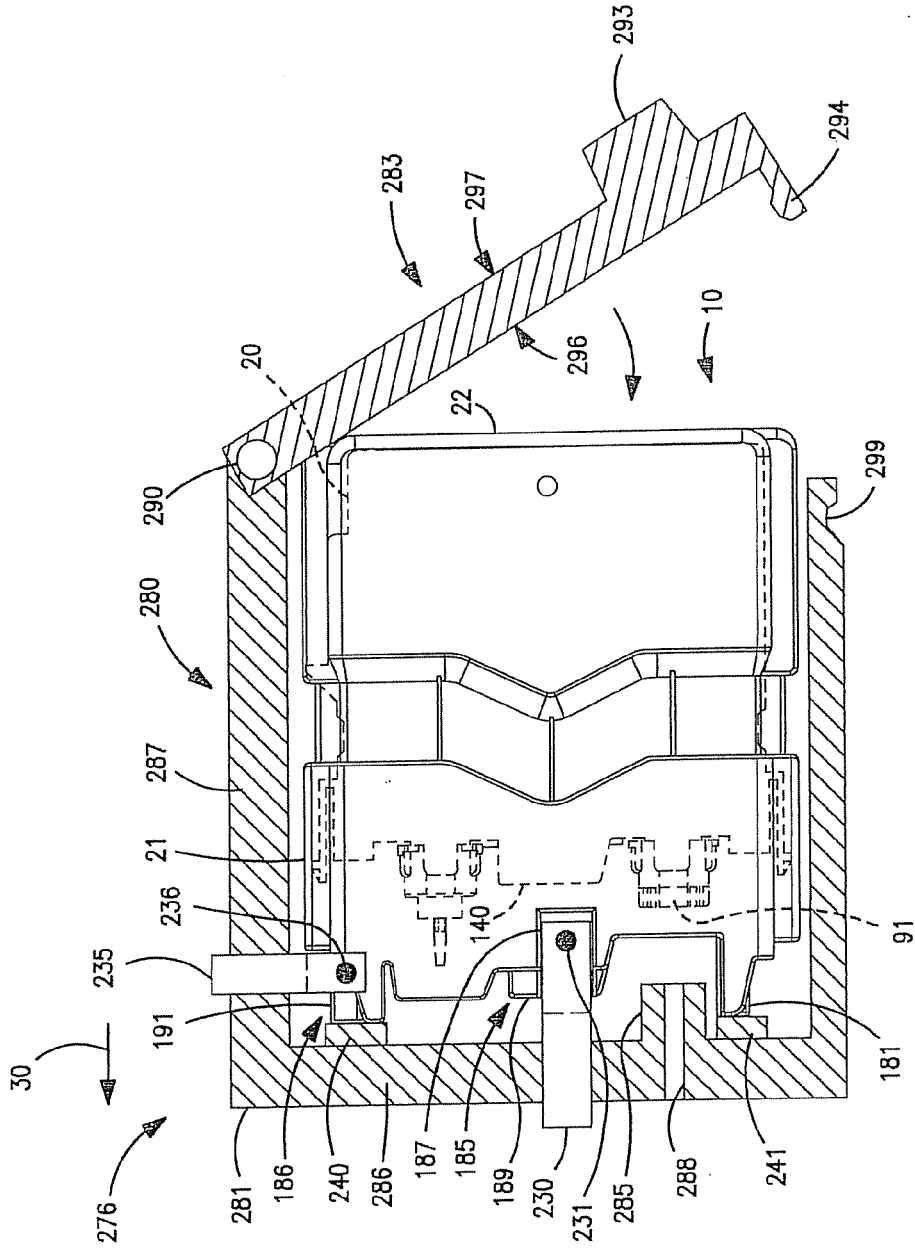

FIG. 14

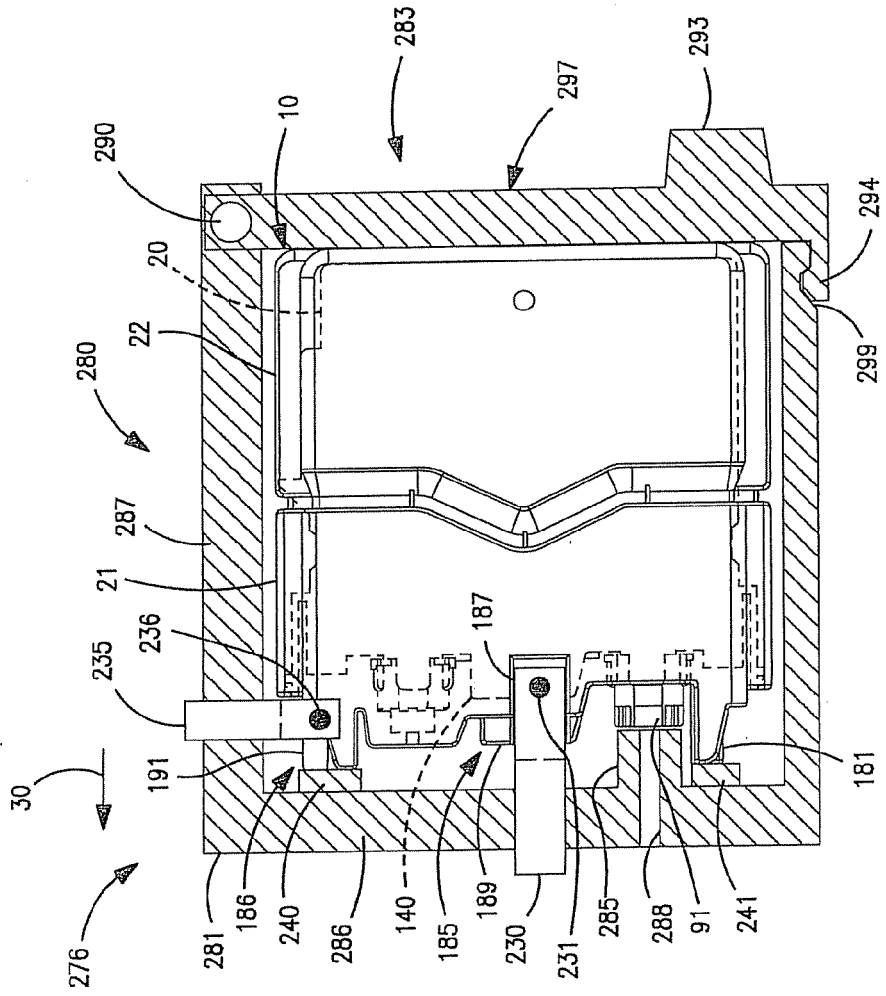

FIG. 15

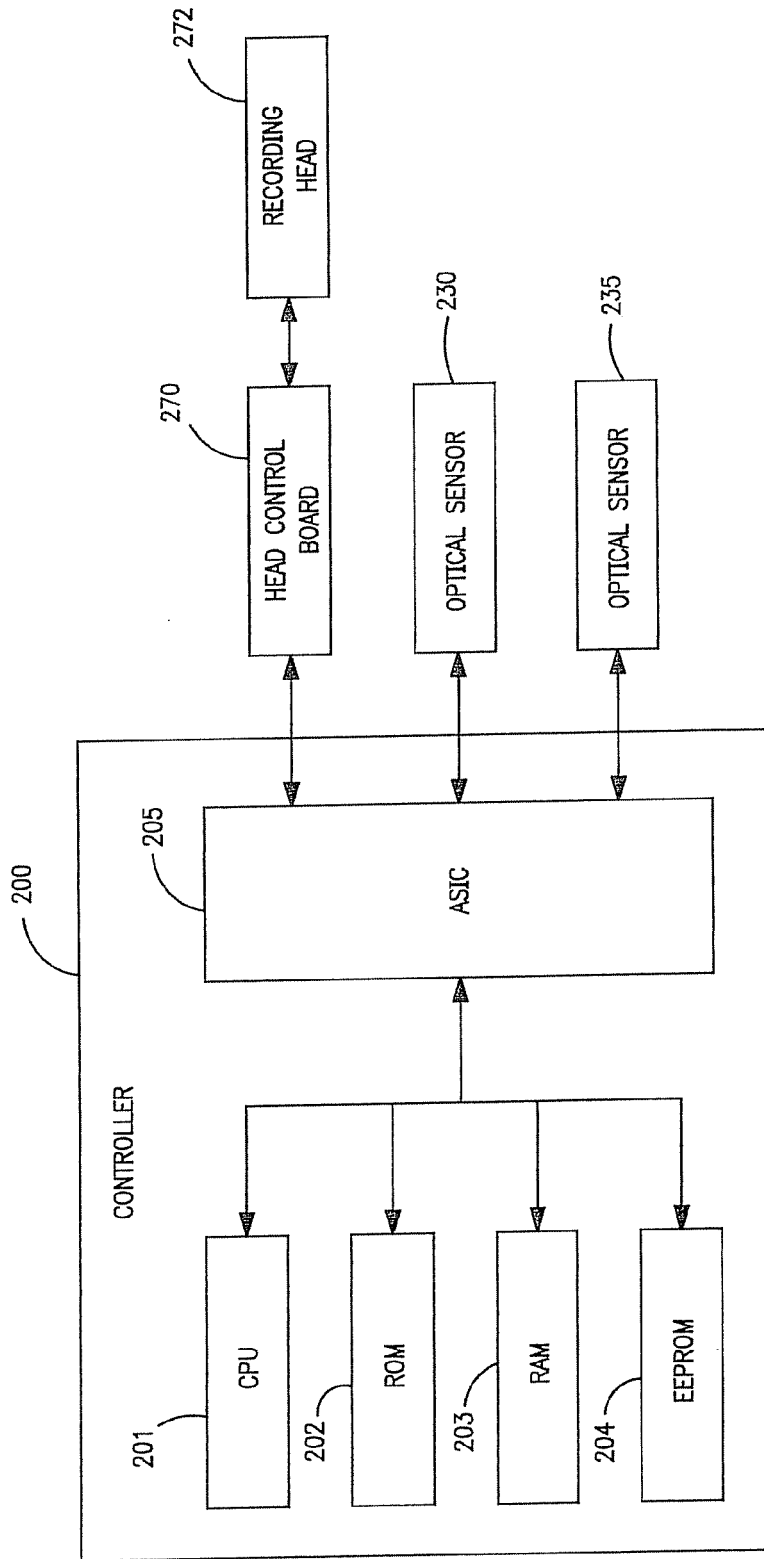

FIG. 16

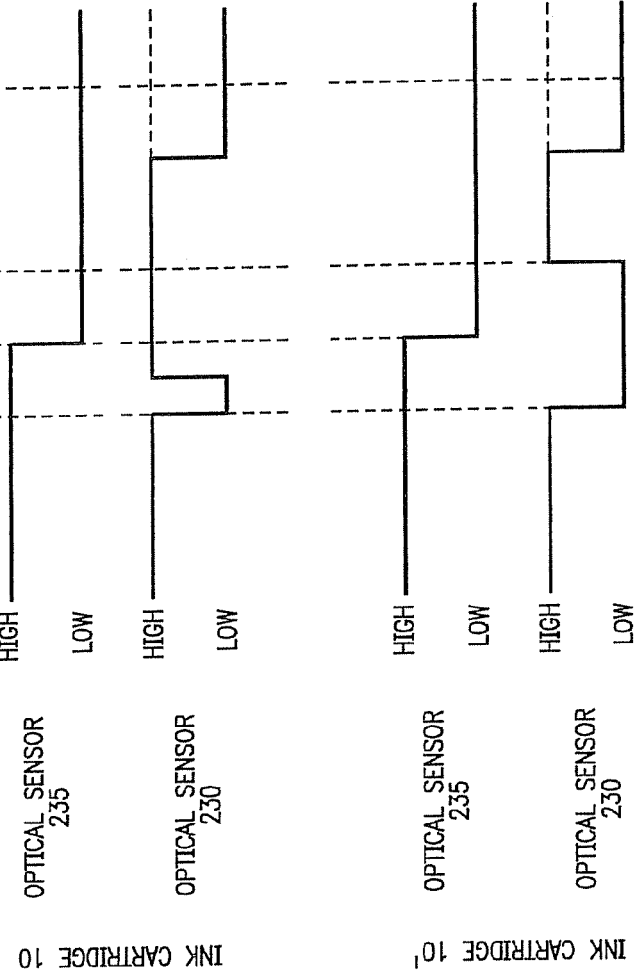

FIG. 17(a)

FIG. 17(b)

FIG. 17(c)

FIG. 17(d)

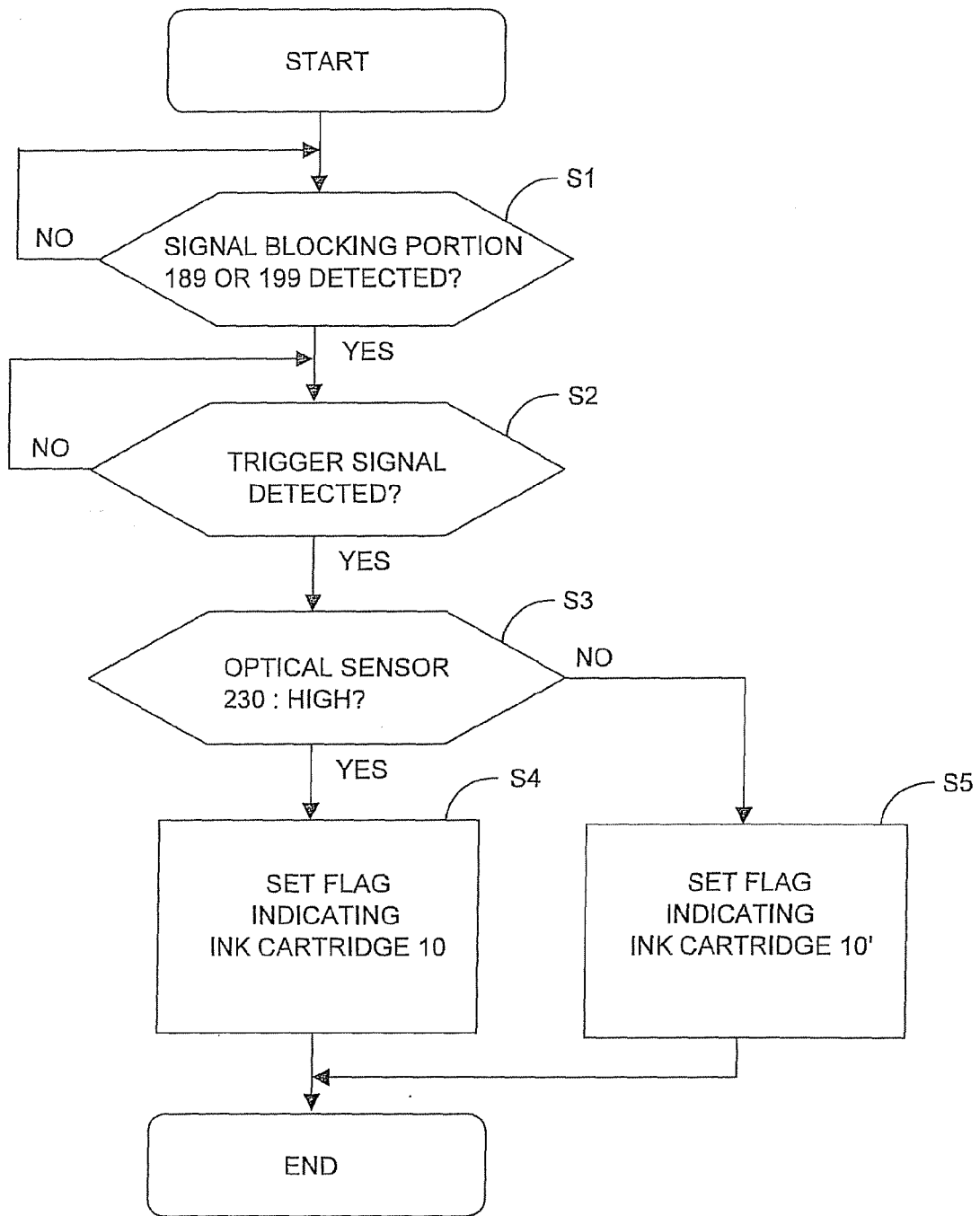

FIG. 18

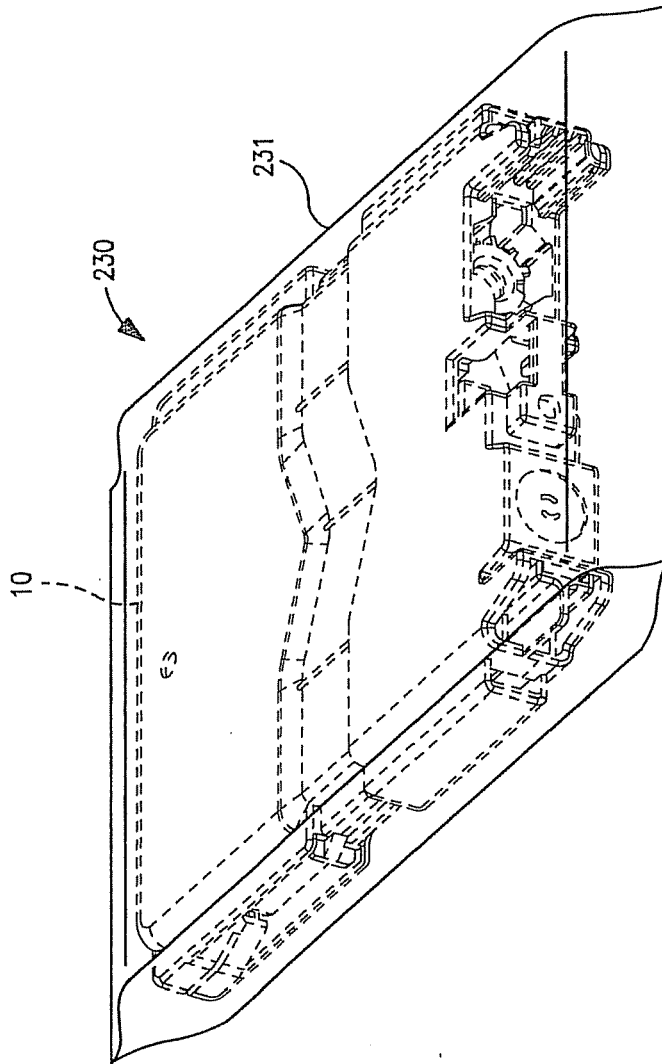

FIG. 19

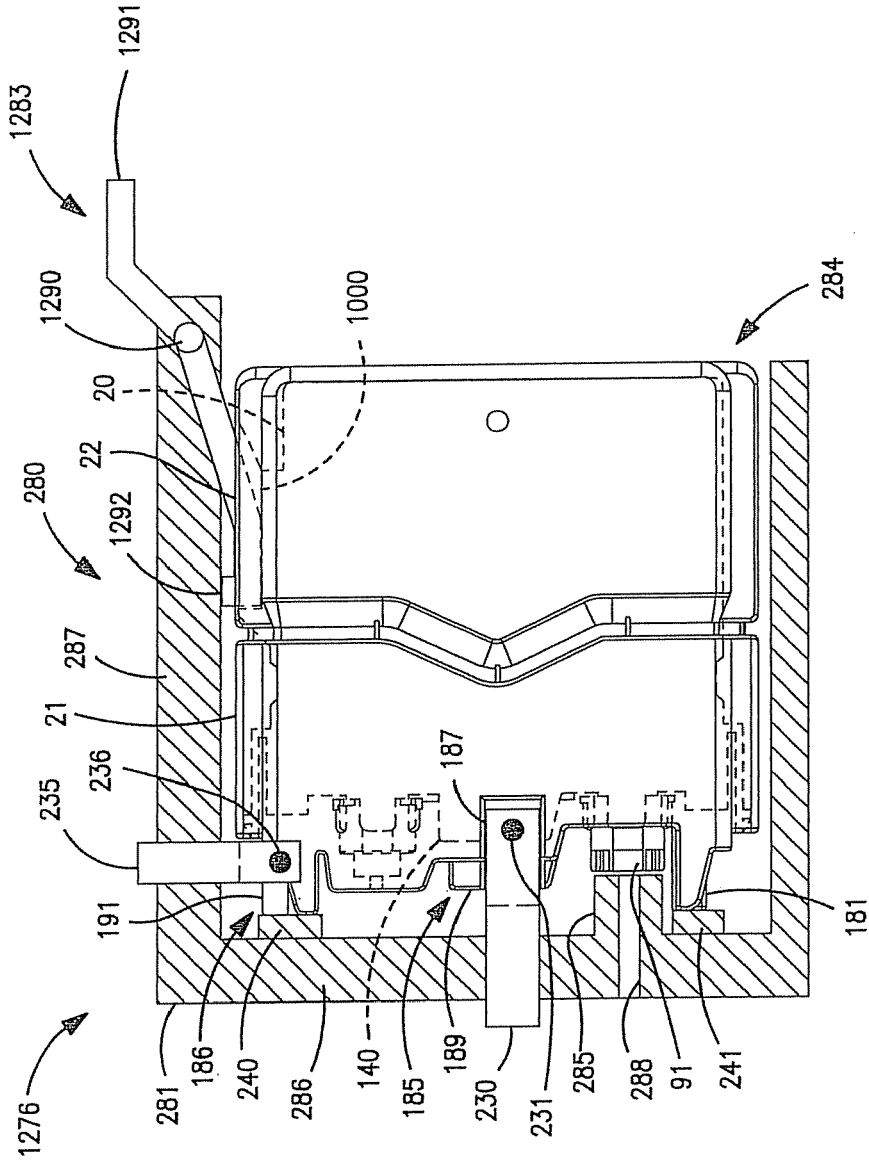

FIG. 20



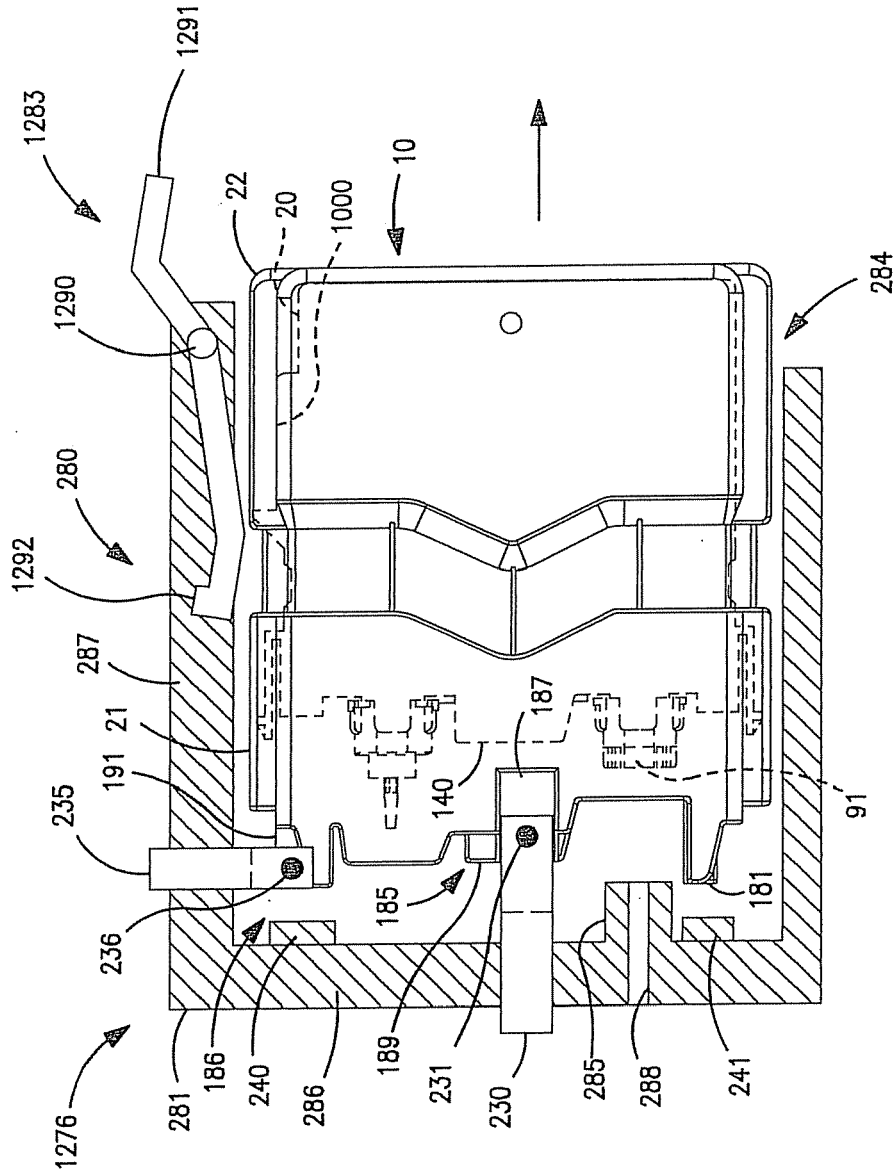

FIG. 21

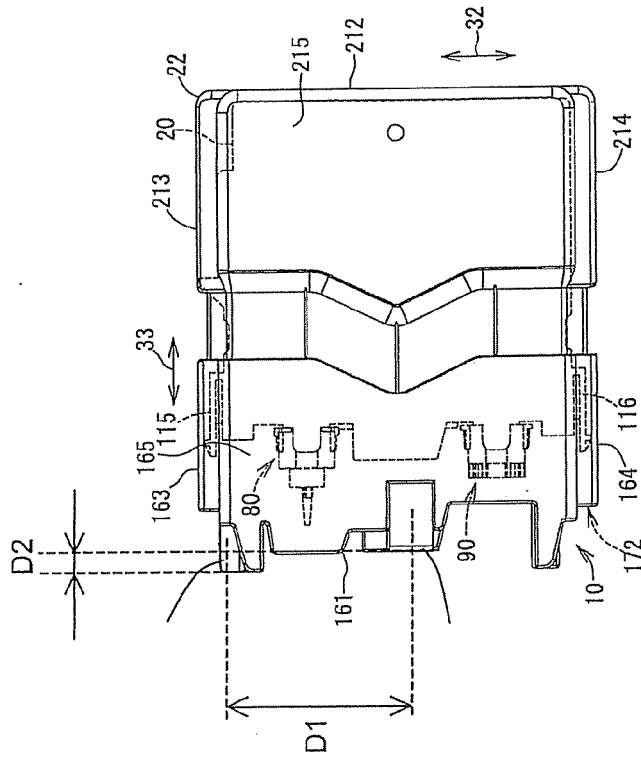

FIG. 22(b)

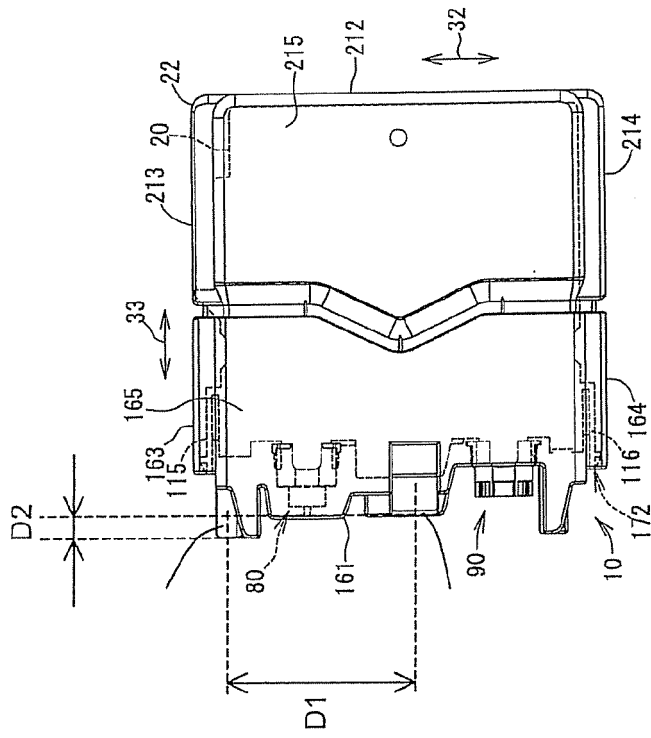

FIG. 22(a)

**REFERENCES CITED IN THE DESCRIPTION**

*This list of references cited by the applicant is for the reader's convenience only. It does not form part of the European patent document. Even though great care has been taken in compiling the references, errors or omissions cannot be excluded and the EPO disclaims all liability in this regard.*

**Patent documents cited in the description**

- US 20050024454 A1 [0003]
- US 20050195225 A1 [0004]