

(19)



(11)

EP 2 435 339 B9

(12)

CORRECTED EUROPEAN PATENT SPECIFICATION

(15) Correction information:

Corrected version no 1 (W1 B1)

Corrections, see

Description Paragraph(s) 22, 23, 24

(51) Int Cl.:

B65D 81/38 (2006.01) F25D 3/12 (2006.01)

(86) International application number:

PCT/GB2010/001059

(48) Corrigendum issued on:

03.07.2013 Bulletin 2013/27

(87) International publication number:

WO 2010/136771 (02.12.2010 Gazette 2010/48)

(45) Date of publication and mention

of the grant of the patent:

01.05.2013 Bulletin 2013/18

(21) Application number: **10728266.7**

(22) Date of filing: **29.05.2010**

(54) **A TEMPERATURE CONTROL SYSTEM**

VORRICHTUNG ZUM KÜHLHALTEN

SYSTEME DE MAINTIEN DE TEMPERATURE

(84) Designated Contracting States:

**AL AT BE BG CH CY CZ DE DK EE ES FI FR GB
GR HR HU IE IS IT LI LT LU LV MC MK MT NL NO
PL PT RO SE SI SK SM TR**

(72) Inventor: **TATTAM, Edwin, Francis**

Somerset BA8 0AP (GB)

(30) Priority: **29.05.2009 GB 0909249**

(43) Date of publication of application:

04.04.2012 Bulletin 2012/14

(74) Representative: **Humphrey-Evans, Edward John**

Humphrey-Evans

Intellectual Property Services Limited

1 Hawkes Close

Wokingham

Berkshire RG41 2SZ (GB)

(73) Proprietor: **SOFTBOX SYSTEMS LIMITED**

Long Crendon

Buckingham

HP18 9BF (GB)

(56) References cited:

EP-A2- 1 291 300

WO-A2-2005/007519

DE-U1-202005 018 423

EP 2 435 339 B9

Note: Within nine months of the publication of the mention of the grant of the European patent in the European Patent Bulletin, any person may give notice to the European Patent Office of opposition to that patent, in accordance with the Implementing Regulations. Notice of opposition shall not be deemed to have been filed until the opposition fee has been paid. (Art. 99(1) European Patent Convention).

Description

Field of Invention

[0001] The present invention relates to a temperature control system for containers, such as transport containers which are employed to transport goods in aircraft. In particular, the present invention relates to a passive system for the same.

Background to the Invention

[0002] In the field of logistics, that is the field of movement and supply of produce and materials, in particular in the transport of intermediate and finished products, containers have been developed which safely protect from physical damage a wide variety of product. However, certain types of products, such as pharmaceutical and food products not only need protection from physical shock and pressures but also require temperature stability during transportation; otherwise goods can be damaged and be unusable, whether such damage is apparent or not.

[0003] For example, in the pharmaceutical industry, product often needs to be maintained within a temperature range: product may be packed in relatively small containers, which containers are relatively fragile - accordingly insulation must provide both physical and thermal stability. Small cargos of pharmaceuticals can be extremely valuable, not just in financial terms, but possibly also in terms of health. Destruction by poor handling of pharmaceuticals can have far-reaching consequences. Equally, in the food industry, fish suppliers will often have chilled fish boxes which are designed to accept, say 20Kg of product. The fish must be maintained at low temperatures, yet will be placed in containers which require a high degree of strength to prevent spillage.

[0004] As the standards of living increases, in developed markets, for example in Europe and North America, tropical foods - that is foods grown in far-away tropical places - are increasingly being stocked by supermarkets, delicatessens and the like. Short pick to distribution centre times in the producing country are matched by air carriers taking goods to the countries of consumption in similar lengths of time, whereby it is not uncommon for fruit to be on the plates of householders within two to three days of having been picked in a far-away country.

[0005] However, air transport poses a particular problem: Goods can be transported in tropical heat, packaged and placed upon pallets and the like containers whereby they are presented in aircraft style containers. Such goods may be left on runways at extreme temperatures (+40° C) and then placed within a hold where low pressures and low temperatures exist during flight. At a destination airport the temperatures may well be sub-zero. A corollary to this is the production of temperature sensitive pharmaceuticals in a "developed" country which pharmaceuticals must be transported to another side of

the world with similar temperature variations.

[0006] Both the above scenarios place transport managers in difficult positions. For air haulage, containers should weigh little, make use of non-rectangular hold spaces within aircraft; for the goods, they must be protected from shock, be maintained within a narrow temperature range, sometimes being equipped with temperature data loggers whereby a record of temperature within a container may determine whether or not a pharmaceutical is destroyed prior to use because of poor temperature handling. Refrigeration units may be provided with a container whereby temperatures maybe maintained, but then a source of electrical power or fuel for a powered generator is required. An example of such a temperature control system is shown in CN20136863 to Hefei Midea Royalstar Refrigeration Company.

[0007] To simplify transport with respect to airports, planes and handling equipment, there have been developed aircraft Unit Load Devices (ULDs) which comprise any type of pallet or container that can easily be loaded to the aircraft by a ground handler. Aircraft ULDs are units which interface directly with an aircraft loading and restraint system, without the use of supplementary equipment. There are pre-defined ULDs, such as LD3, LD7, which correspond to standard configurations and can be utilised on certain types of aircraft. There are still further ULDs that are shaped such that they have a rectangular base yet are not generally cylindrical, that is to say they extend outwardly, beyond the sides of the base, as they extend upwardly from the base. KR 20080100401 provides a multi combined packing container is provided to improve the products value of the fresh food through low temperature refrigeration circulation in the current fresh food circulation system. The multi combined packing container comprises first, second third and fourth packing materials - arranged in a fashion similar to a Russian doll assembly, wherein the third packing material is a form of refrigerant pack and is inserted inside the second packing material; the fourth packing material is inserted inside the third packing material.

[0008] Other known forms of chilling products such as ice packs comprise polymer coolants packaged within bags can provide simple means to cool products. Coolant gels may also be employed, being inserted into plastics containers, typically being, but when packed do not necessarily offer sufficient heat transfer. However, in the nature of transport containers, the gel packs can move or otherwise become dislodged from a selected place whereby an inappropriate temperature gradient can occur, whereby a required temperature for a medicine, vaccine, food or other product is not maintained; products such as vaccines that have not been maintained within a required temperature range during transport must be disposed of without use. It will be appreciated that if a container of, say, a freezable gel is knocked from a normal placement position and leaks to a joint between two panels of a container, the temperatures encountered within aeroplanes is substantially below 0°C; subsequent

freezing and cooling can damage the container irreparably and damage contents within.

[0009] It is notable that there are few passive thermal exchange devices for cargo containers; few can provide sufficient cooling properties; few can remain where placed during transport as a matter of course. Further, in terms of containers, cooling systems need to be easily removable and be capable of being packed flat, along with an associated insulating cargo containers; either they are rigid yet not collapsible or are collapsible yet easily damaged when shifted by fork-lifts and other and/or are complex to assemble.

Object of the Invention

[0010] The present invention seeks to provide a solution to the problems addressed above. The present invention seeks to provide a temperature control system for a transport container which can be manufactured at low cost and can readily and easily be constructed from a flat-pack as is the case of a container within which it can be placed. Furthermore, the present invention seeks to provide a temperature control system for a transport container that when completed can maintain goods placed inside the container within a narrow temperature range.

[0011] Additionally, the present invention seeks to provide a passive temperature control system that takes up little space and can be simply used with flat-pack storage containers. The present invention further seeks to provide a temperature control system for a transport container which is compatible with standard Unit Load Device specifications.

Statement of Invention

[0012] According to the invention, there is provided a transport container temperature control system as defined in claim 1, having a foldable sleeve and a temperature control pack.

[0013] Conveniently, the sleeve comprises sheet material, such as corrugated plastics or corrugated cardboard, configured to define an aperture for the placement of a standard shape coolant package. Known coolant packages can be manufactured from a plastics material and be filled with a gel material or can comprise one or more plastics bags containing a coolant material which are inserted into a cardboard box. For simplicity, the coolant package will define a body which has a high heat capacity and is operable to maintain a temperature - that is to say the coolant, by virtue of its high thermal capacity, can assist in maintaining a temperature above ambient, in a fashion similar to maintaining a temperature below ambient. Corrugated plastics or corrugated cardboard are materials that are commonly used in transport industries and is both relatively cheap and readily available.

[0014] Conveniently, a container operably utilised with the invention comprises at least a base and upstanding

wall panels, wherein the base panel corresponds to the first panel type and the wall panels correspond to the second panel type. Preferably, the container is of the type wherein adjacent panels have cooperating tongue and groove edges, whereby the container, when closed, is substantially airtight. By having a container substantially air tight, when cool packs are employed is significant since, not only does an exchange of air with the atmosphere outside the container contribute to an increase in temperature within a container, the exchange of air with the atmosphere outside the container will also bring about condensation of the saturated air when cooled and possible frosting upon the cool packs. It will be realised that, subsequently, any temperature cycling, including frosting can affect the integrity of materials such as cardboard.

[0015] In accordance with another aspect of the invention, there is provided a flat-pack transport container as defined in claim 8. The container can have a variety of forms, but a rectangular box is typically employed, even though it would be possible to have square section or cylindrical section boxes. The walls of such a container are provided with the coolant sleeves. Preferably, the container further comprises one or more insulating cover panels, which insulating cover panels correspond in type with either the first or second panel type, whereby the cover panel can be resiliently retained with respect to an upstanding wall panel.

[0016] The insulating panels forming the walls of the container can be fabricated from one or more types of panel including extruded polystyrene, polyurethane foam, expanded polystyrene, cardboard, laminated polyurethane foam, laminated expanded polystyrene. The laminate face can comprise one of card, plywood, polypropylene, aluminium or steel.

[0017] Conveniently, a weatherproof sheet is arranged about the assembled container in use. Preferably, the weatherproof sheet provides a thermal barrier. Conveniently the weatherproof sheet is retained by a cargo net., which attaches within a recess of a pallet base to provide an integrated weatherproof container system which is resilient to of goods to be transported within the transport container, a thermal sheet surrounds the panels and are retained by a cargo net, which are retained by and cooperate with the base member. Conveniently, the cargo net comprises any one or more of webbing or elasticated cords. Conveniently, the net has feet which locate into channels defined along peripheral edges of the base.

[0018] A container temperature control pack in accordance with the present invention may be assembled in a rapid and expeditious manner. The parts making up the temperature control pack may be stacked for storage in a relatively small space, conveniently being prior attached to a panel for a container, and may be associated with a container also arranged in a flat-pack style. A distinct benefit of the present invention is that the construction permits the same size temperature control packs to be utilised in different containers; commonality of parts

between ranges of product can provide more cost-effective construction and/or different functionality.

Brief Description of the Figures

[0019] For a better understanding of the present invention, reference will now be made, by way of example only, to the Figures as shown in the accompanying drawing sheets, wherein:-

Figure 1 illustrates a ULD transport container;
 Figure 2 illustrates a container with weatherproof sheeting;
 Figure 3a - 3c detail a first embodiment of one aspect of the invention;
 Figure 4 shows a container with coolant sleeves in accordance with one aspect of the invention;
 Figure 5 shows a second embodiment of the invention in perspective view;
 Figures 6a, b show side and plan views of a sleeve in accordance with the invention;
 Figures 7 & 8 show a cardboard blank and completed sleeve;
 Figures 9a & b show a sleeve in first and second states of compression;
 Figures 10a, b & c show a temperature control pack;
 Figures 11 shows a photograph of an open end of sleeve;
 Figure 12 shows a view of a compressed sleeve;
 Figures 13a, b show a temperature control pack from an end view and perspective view respectively;
 Figure 14 shows an empty sleeve; and
 Figure 15 shows a further embodiment with a partially inserted temperature control pack.

Detailed description of the Preferred Embodiments

[0020] There will now be described, by way of example only, the best mode contemplated by the inventor for carrying out the present invention. In the following description, numerous specific details are set out in order to provide a complete understanding to the present invention. It will be apparent to those skilled in the art, that the present invention may be put into practice with variations of the specific.

[0021] Figure 1 shows an example of a container as is disclosed in GB2459392, which has the dimensions of a standard ULD container. Whilst a base panel is not shown in any detail, side panel members 22a-c & 23a, b are arranged such that a lower edge portion of the panel members are engaged in rebates defined by the base member. In this teaching a rebate is defined between the base member and "L" section elements attached to the base member, but the present invention can be employed in containers manufactured and assembled in different fashions. Conveniently, the material would comprise extruded polystyrene or polyurethane foam and have a thickness of approximately 50 - 80 mm. The corners of

the rectangular container are arranged in mutually similar rebate and edge panel connection. In use, for example, as an LD7 container, the container panels are mounted upon a pallet and then an aluminium base which conforms to specifications of international aircraft standards; a cargo net comprising elasticated webbing 26 is attached via plugs which locate in a perimeter rail of the base. Whilst the insulating panels closely fit together to prevent gaseous exchange - and thus heat transfer - it is common for thermally insulating outer bags to be employed in the transport of temperature sensitive produce and such a bag could be placed around the container and be secured by the cargo net 26. Figure 2 shows a container with weatherproofing.

[0022] Figure 3a shows a first embodiment of the invention; sleeve 50 comprises a generally oblong box, open at a top end, 51 and a lower end, 59. The sleeve 50 is attached to an inside wall of a container panel, with the lower end in close proximity to a base of the container. The refrigerant sleeve can comprise, in a simple embodiment, a cardboard enclosure, having a rear wall which is attached to a wall of a container, for example by double sided tape. Cardboard is cheap and readily available, although corrugated plastics can be utilised. The lower end of the sleeve may, in actual fact (though not necessarily preferred), be in touching proximity with the base. Front face 50 of the pack is spaced by a distance d from the coolant pack 53 in use by virtue of spacing means 52 which may comprise a separate cardboard wall or, conveniently a plastics foam spacer. These sleeves comprise containment means for temperature control packs, having a high thermal capacity: A first enclosure 51 is for placement of refrigerant or coolant packs such as gel - packs 53 and similar objects with a high thermal capacity. In use, it lies adjacent a container wall 54; a second element 52 provides a minimum distance, d_m , between the gel - packs and the product (not shown). Apertures 55 can be provided in a wall of the first enclosure to enable the position of a coolant pack within to be determined. Equally, such aperture may assist in allowing convection currents to flow.

[0023] Figure 3b shows a coolant pack 53 in a state of partial state of insertion in an exaggerated off-centre fashion with respect to the sleeve. Figure 3c show how refrigerant pack 53 per Figure 3b is flush with the top of the sleeve. A few thermodynamic concepts are involved here: heat transfer, heat absorption, and phase change. These principles are some of the components of the "zeroth law" of thermodynamics. That is, all systems attempt to reach a state in which heat energy is equally distributed. If an object with a higher temperature comes in contact with a lower-temperature object, it will transfer heat to the lower-temperature object. It is to be noted that certain goods must be maintained below ambient temperature; others at above ambient temperature and some at elevated temperature. Turning now to Figure 4, there is shown the container as shown in Figures 2a & 2b. Box 41 is a box with temperature sensitive contents; it needs

to be maintained within a specific, limited temperature range. The invention provides sleeves or envelopes 28a attached to the inside walls of the container. Box 41 is mounted upon a base 21a which can be supported by a pallet (not shown), which is, in turn, placed upon base member 42. In this Figure, there is also shown shows cardboard envelopes 28a and boxes 28b which can retain gel packs, for example, which have a high heat capacity whereby to assist in the maintenance of a particular temperature. The base, side and top panels of the container may all be manufactured from plastics foam sheets, such as extruded polystyrene or polyurethane. However, in certain circumstances, the panels may comprise expanded polystyrene sheathed with, for example, cardboard, polypropylene sheeting or other types of sheathing, including glass reinforced plastics.

[0024] An advantage of the use of some sheathing materials is that an L-member may be integrally moulded, if the container is one made in accordance with the teaching of GB2459392. However, as shown, the long-side panels 23a - 23c have interlocking features between themselves, conveniently by way of corresponding rebates, whereby to minimise the presence of any gaps therebetween. Panels 23a and 23c have vertical L-members 32 attached thereto; similarly the short-side panels 24a, 24b interlock with each other and with adjacent panels of the long-sides, the L-member ensuring that there are no gaps between the corners edges between adjacent side wall panels. Specifically, a first panel defines a rebated channel on an inside face of the panel, the channel being adjacent to at least one edge, the rebate being defined in cross-section by an edge face of the panel and a general L-shape, a first arm of the L-shape section defining, in use, part of the outside wall of the first member, the second arm of the L-shape section having an inside face opposing said edge face of the panel, whereby to define a rebate into which an edge portion of the second panel can be received and resiliently retained therein. The upper insulating panel 27a, as mentioned above is generally similar to the base panel and engages with the upper edges of the side-wall panels, the L-members assisting in maintenance of gap-free edges between the side panels. By having separate panels resiliently retained, passage of air between an inside and an outside of a container is

[0025] Referring now to Figure 5, there is shown a view of envelope 50a, which is attached to an inside face 23a of a side panel. This differs from sleeve 50 in that instead of the spacer means being defined by an air barrier between the coolant sleeve 53 - as created by an empty box section of cardboard, for example - and the major face of the sleeve shown in the figure, the spacer comprises expanded polystyrene. It is typical for refrigerant packs or gel packs (and other types of materials) to be employed as a refrigerant, to maintain a product within a specified temperature range, to maintain a thermal environment in an insulated shipping container sufficient to meet the product's temperature requirements.

[0026] By having a thick spacer, even in the unlikely event of a payload being dislodged within a container, direct contact between the load and a refrigerant pack would not be realised. Such packs have previously been placed loosely in the container, sometimes within boxes. However, disadvantages arose in that the refrigerant packs were liable to congregate in a specific area(s), especially when the containers were roughly handled (which may arise due to the nature of stormy weather and/or a poor landing at an airstrip) providing an uneven temperature distribution within a container, perhaps damaging product which comes into contact with the gel - packs; equally, the gel-packs or similar may become damaged and rupture, potentially spoiling the contents of a container.

[0027] The gel-packs comprise units of a solid, being of a generally rectangular shape. With reference to Figure 6, which shows a side view of a sleeve in position upon a container wall 29a, Applicants have determined that by reducing the width of the enclosure 51 from the top w1 to a width w2, where w2 is less than (say 92-98%) the width of a gel pack w3, then the gel packs can be safely inserted into an enclosure without fear of the pack becoming dislodged as a panel is erected (it will be appreciated, since the height of a side panel of a unit load device is frequently of the order of 2m or more, that the subsequent insertion of a gel pack is ill-advised, since the gel pack could be liable of not being placed properly within its designated place, if any). The exact width of w2 would be dependent upon the materials employed, cardboard having more give than a typical plastics board. This could also be of advantage in use of the container, to prevent spillage. The envelope may be placed such that it has a gap between a floor of the container, whereby to assist in the use of convection currents to provide a uniform temperature within the atmosphere of the container.

[0028] Whilst the dimensions of the gel pack can vary, a pack size that has been found to be of a convenient size and weight (3Kg) is dimensioned 44.7cm x 28.6cm x 3.6cm. The envelope is conveniently manufactured from corrugated cardboard. Three or more gel packs may be inserted within an envelope. Since it is a commonly used material in the packaging industry and the skills for fabricating and attaching the envelopes are well known. A length of tape may be attached to an upper section of an aperture, in the middle of a face of the aperture; by placing a lower side of a gel pack in contact with the tape, the pack may be lowered in a controlled fashion. A gel pack may have an indentation upon an edge to assist in this procedure, without fear of the gel pack slipping either side of the tape.

[0029] Referring now to Figure 7, there is shown a plan view of a cardboard sheet prior to initial folding and having a rounded 75 indicia operable to help handlers to locate and position a coolant sleeve when attached to a foam panel and spacer foam. Front face 50 is attached to a spacer foam and is separated by leave 71, 72 separated by intermediate elements 73 which define the thickness

of the coolant packages which are installed within a sleeve. Figure 8 shows how the cardboard tube is formed prior to placement with a spacer and attachment to a wall of a container panel. The advantage of using a thin card or cardboard like material is shown in Fugre9a and 9b where a sleeve is shown in section in open and folded states. As mentioned elsewhere, the ability to reduce storage space for unused cartons is particularly welcome, especially in the air freight industry where volume has a cost, not just weight.

[0030] Figures 10a & 10b show first and second perspective views of coolant packs, manufactured from cardboard or plastics sheeting, say of 0.5 - 2.0 mm in thickness. A suitable card could comprise die-cut corrugated board grade C180W200K175SC; a suitable plastics is low density poly ethylene, LDPE. In use, these are filled with gel packs comprising gel/chlorine biocide mix, the gel being formed from a water/superabsorbent polymer mix at 0.3% polymer to water, as is known. The water would typically be triple treated - carbon filtered, UV treated and chlorinated, to comply with national, international and industrial regulations. A convenient size of gel pack has been found to be 450mm x 287mm x 40mm. Figure 10c shows an outline of a card which would be folded to produce a refrigerant pack

[0031] Referring now to Figures 11 - 15, there are shown details of various aspects of the invention, Figures 11 shows a photograph of an open end of sleeve; which is shown in a compressed state in Figure 12. A temperature control pack is shown from an end view and from a perspective view respectively | Figures 13 a & 13b. An empty sleeve is shown in Figure 14 - a double sided tape is used to enable a plastics buffer element to be attached to face 50 of coolant sleeve. Figure 15 shows a further embodiment with a partially inserted temperature control pack.

[0032] The foam panels of a container are conveniently of a laminated construction, whereby, using different densities of foam a lightweight yet stiff structure can be provided. Conveniently these can be provided by commercially available HCFC-free expanded Polyethylene sheet (LDPE), where there is a closed cell structure with extrusion skin. This provides a low water absorption and water-vapour transmission rate. The foam has a high resiliency and flexibility, excellent cushioning behaviour and excellent thermal insulation properties, with a temperature stability of -40 to +70°C. Commercially available foams of such construction are manufactured by companies such as Knauf Insulation Ltd., Sealed Air Inc. etc.. It has also been found that when laminated panels of differing density are employed, there is a reduced tendency of the product panels to bow. Through an appropriate choice of materials, lightweight panels can be selected to provide a resilient container which can elastically deform and return to an original position, albeit in a limited fashion.

[0033] It will be appreciated that variations of the insulating base and L-member are possible. For example,

the base material may comprise a rebated portion and the L-member horizontal arm would be completely in contact with the underside of the insulating base material. By the provision of such an arrangement, goods can be placed upon a base prior to erection of walls of the container, with a subsequent erection of the walls by the simple act of inserting them within a channel defined in part by the L-members, without fear of the wall collapsing. This has been found to enable a rapid loading of air-cargo pallets, for example. It will be appreciated that a rapid transfer of product shortens the time that product will not be in a temperature-controlled environment. In a most simple embodiment of the invention, only the base insulating member L-members extending from the outside edges thereof. Notwithstanding this, it is preferred that at least the top portions of the container have panels with the L-members extending from outer edges, whereby to enable the goods to be covered in an equally simple fashion. In the alternative, straps could be placed around the top of the container and around the sides, but many of the advantages of the speed of erecting the containers will be lost. Equally, the corner elements of the sidewall should similarly be protected.

[0034] In summary, several features worthy of mention are: A) The coolant sleeves or envelopes fold flat to reduce height when shipping to point of use as well as for return logistic operations when systems are flat packed and returned either by air or more often sea container. The actual result of this feature is that the Single Pallet System is reduced in height by 200mm or 22%, The Half LD7 System by 300mm or 25% and the Full LD7 System by 500mm or 25%. B) The insulation, such as XPS plastics provides a buffer layer attached to the front of the corrugated coolant envelope provides an integrated insulation buffer layer that avoids the temperature of chilled product being shipped from freezing as a result of placement directly next to a coolant pack inserted into the system at - 20C. The thickness of such a layer need be only be 15 - 20mm, preferably 17.5 for many products, to provide an effective barrier; and C) The tapering of the corrugated coolant envelope from its top aperture of 460mm to 440mm (on one model) over distance of approximately 1m at its bottom is specifically designed to avoid the coolant packs hitting the base insulation panels of the system, causing potential rupturing and leakage of coolant. When inserted into the coolant envelope, the first coolant pack slows or stops approximately 100mm from the base insulation panel with subsequent packs inserted pushing the first pack gradually down to meet the surface of the base insulation panel.

Claims

1. A transport container temperature control system for use in a transport container having a base and at least one side wall and a cover, the temperature control system comprising at least one sleeve (50) fold-

- able between an unfolded and a compressed state and having first and second major planes, and at least one temperature control pack (53), the sleeve being attachable prior to first use along one of its major planes to a major plane of an inside wall of the container, each sleeve being operable in the compressed state to permit the container to be collapsed and in the unfolded state to retain a temperature control pack within, to maintain a temperature of an atmosphere within the container when closed by virtue of heat transfer with the atmosphere of the container; and to prevent contact with any product.
2. A temperature control system according to claim 1, wherein the sleeve (50) includes spacer means (52, 52') configured to determine a minimum distance between product within a container and a temperature control pack within the sleeve.
 3. A temperature control system according to claim 1 or 2, wherein the spacer means comprises one of cardboard, an air space defined by cardboard (52) or plastics, and a plastics insulation layer (52').
 4. A temperature control system according to any one of claims 1 - 3, wherein the sleeve comprises sheet material configured to define an aperture for the placement of a standard shape temperature control pack.
 5. A temperature control system according to any one of claims 1 - 4, wherein the sleeve has apertures (55) in a wall thereof whereby to enable the contents of the sleeve to be viewed.
 6. A temperature control system according to any one of claims 1 - 5, wherein the sleeve has, in use, an upper section (51) and a lower section (59), the internal width (w_1) of the upper section being dimensioned to allow the passage of a temperature control pack into the aperture of the sleeve, the internal width (w_2) of the aperture at the lower section being less than the width of a temperature control pack.
 7. A temperature control system according to any one of claims 1 - 6, wherein the temperature control pack (53) is manufactured from a plastics material and is filled with a gel material or from cardboard and is filled with a gel material within a plastics bag, said gel material having a high thermal capacity.
 8. A flat-pack transport container (20) with a temperature control system, the flat-pack transport container having a base and at least one side wall and a cover, operable to carry product placed upon the base, said temperature control system comprising at least one foldable between an unfolded a compressed state and sleeve having first and second major planes, and at least one temperature control pack, one of the major planes of the sleeve being attached to a wall portion of the container, wherein, the sleeve is operable in the compressed state to permit the container to be collapsed and in the unfolded state to retain a temperature control pack, to maintain a temperature of an atmosphere within the container when closed by virtue of heat transfer with the atmosphere of the container; and, to prevent contact of the temperature control pack with any product.
 9. A transport container according to claim 8, wherein the spacer means comprises one of cardboard, an air space defined by cardboard or plastics, and a plastics insulation layer.
 10. A transport container according to claim 8 or 9, wherein the sleeve comprises sheet material configured to define an aperture for the placement of a standard shape coolant package.
 11. A transport container according to any one of claims 8 - 10, wherein the sleeve has apertures (55) in a wall thereof whereby to enable the contents of the sleeve to be viewed.
 12. A transport container according to any one of claims 8 - 11, wherein the sleeve has, in use, an upper section (51) and a lower section (59), the internal width (w_1) of the upper section being dimensioned to allow the passage of a temperature control pack into the aperture of the envelope, the internal width (w_2) of the aperture at the lower section being less than the width of a temperature control pack.
 13. A transport container according to any one of claims 8 - 12, wherein the temperature control pack is manufactured from a plastics material and is filled with a gel material or from cardboard and is filled with a gel material within a plastics bag, said gel material having a high thermal capacity.
 14. A transport container according to any one of claims 8 - 13, wherein the insulating panels are fabricated from one or more types of panel including extruded polystyrene, polyurethane foam, expanded polystyrene, cardboard, laminated polyurethane foam and laminated, expanded polystyrene.

Patentansprüche

1. Ein Transportbehälter-Temperaturüberwachungssystem zur Verwendung in einem Transportbehälter, der über einen Boden und mindestens eine Seitenwand und einen Deckel verfügt, wobei das Temperaturüberwachungssystem mindestens eine Hülle

- (50) beinhaltet, die zwischen einem nicht gefalteten und einem komprimierten Zustand faltbar ist, und eine erste und zweite Hauptebene und mindestens ein Temperaturüberwachungspaket (53) aufweist, wobei die Hülle vor der ersten Verwendung entlang einer seiner Hauptebenen an einer Hauptebene der Behälterinnenwand befestigt werden kann, wobei jede Hülle in einem komprimierten Zustand funktionsfähig ist, sodass der Behälter auch in einem zusammengeklappten und nicht aufgefalteten Zustand ein Temperaturüberwachungspaket aufnehmen kann, damit eine Temperatur einer Atmosphäre innerhalb des verschlossenen Behälters dank der Hitzeübertragung mit der Atmosphäre des Behälters aufrechterhalten wird und damit der Kontakt mit einem Produkt verhindert wird.
2. Temperaturüberwachungssystem gemäß Anspruch 1, worin die Hülle (50) einen Abstandhalter (52, 52') beinhaltet, der dazu dient, einen Mindestabstand zwischen dem Produkt innerhalb eines Behälters und einem Temperaturüberwachungspaket innerhalb der Hülle festzulegen.
 3. Ein Temperaturüberwachungssystem gemäß Anspruch 1 oder 2, worin der Abstandhalter entweder einen Karton, einen durch den Karton (52) oder Plastik definierten Luftzwischenraum oder eine Plastikisolierschicht (52') umfasst.
 4. Ein Temperaturüberwachungssystem gemäß einem der Ansprüche 1 - 3, worin die Hülle ein Plattenmaterial beinhaltet, das dazu dient, eine Öffnung für die Unterbringung eines Temperaturüberwachungspakets, welches eine Standardform aufweist, zu definieren.
 5. Ein Temperaturüberwachungssystem gemäß einem der Ansprüche 1 - 4, worin die Hülle Öffnungen (55) in einer Wand davon aufweist, wodurch der Inhalt der Hülle sichtbar ist.
 6. Ein Temperaturüberwachungssystem gemäß einem der Ansprüche 1 - 5, worin die Hülle während der Anwendung einen oberen Abschnitt (51) und einen unteren Abschnitt (59) aufweist und die Abmessungen der inneren Breite (w_1) des oberen Abschnitts das Einführen eines Temperaturüberwachungspakets durch die Öffnung der Hülle ermöglichen, wobei die innere Breite (w_2) der Öffnung am unteren Abschnitt geringer ist als die Breite des Temperaturüberwachungspakets.
 7. Ein Temperaturüberwachungssystem gemäß einem der Ansprüche 1 - 6, worin das Temperaturüberwachungspaket (53) aus einem plattenförmigen Kunststoffmaterial hergestellt wird und mit einem Gelmaterial gefüllt wird oder aus einem Kartonmaterial hergestellt wird und mit einem Gelmaterial innerhalb eines Plastikbeutels gefüllt wird, wobei das Gelmaterial eine hohe Wärmekapazität aufweist.
 8. Ein Flatpack-Transportbehälter (20) mit einem Temperaturüberwachungssystem, wobei der Flatpack-Transportbehälter einen Boden und mindestens eine Seitenwand und einen Deckel aufweist, der funktionsfähig ist, um ein Produkt, das auf den Boden gestellt wird, zu tragen, wobei das Temperaturüberwachungssystem mindestens eine Hülle beinhaltet, die zwischen einem nicht gefalteten und einem komprimierten Zustand faltbar ist und eine erste und zweite Hauptebene und mindestens ein Temperaturüberwachungspaket aufweist, wobei eine der Hauptebenen der Hülle an einem Wandabschnitt des Behälters befestigt ist, worin die Hülle in einem komprimierten Zustand funktionsfähig ist:
 - damit der Behälter in einem zusammengeklappten und nicht aufgefalteten Zustand ein Temperaturüberwachungspaket aufnehmen kann, damit eine Temperatur der Atmosphäre innerhalb des verschlossenen Behälters dank der Hitzeübertragung mit der Atmosphäre des Behälters aufrechterhalten wird und damit das Temperaturüberwachungspaket nicht mit einem Produkt in Kontakt kommt.
 9. Ein Transportbehälter gemäß Anspruch 8, worin der Abstandhalter entweder einen Karton, einen durch Karton oder Plastik definierten Luftzwischenraum oder eine Plastikisolierschicht umfasst.
 10. Ein Transportbehälter gemäß einem der Ansprüche 8 oder 9, worin die Hülle ein Plattenmaterial beinhaltet, das gestaltet ist, um eine Öffnung für die Unterbringung eines Kühlpakets, das eine Standardform aufweist, zu definieren.
 11. Ein Transportbehälter gemäß einem der Ansprüche 8 - 10, worin die Hülle Öffnungen (55) in einer Wand davon aufweist, wodurch der Inhalt der Hülle sichtbar ist.
 12. Ein Transportbehälter gemäß einem der Ansprüche 8 - 11, worin die Hülle bei Gebrauch einen oberen Abschnitt (51) und einen unteren Abschnitt (59) aufweist und die Abmessungen der inneren Breite (w_1) des oberen Abschnitts das Einführen eines Temperaturüberwachungspakets durch die Öffnung der Hülle ermöglichen, wobei die innere Breite (w_2) der Öffnung am unteren Abschnitt geringer ist als die Breite des Temperaturüberwachungspakets.
 13. Ein Transportbehälter gemäß einem der Ansprüche 8 - 12, worin das Temperaturüberwachungspaket aus einem Kunststoffmaterial hergestellt wird und

mit einem Gelmaterial gefüllt wird oder aus Karton hergestellt wird und mit einem Gelmaterial innerhalb eines Plastikbeutels gefüllt wird, wobei das Gelmaterial eine hohe Wärmekapazität aufweist.

14. Ein Transportbehälter gemäß einem der Ansprüche 8 - 13, worin die Isolierplatten aus einem oder mehreren der folgenden Arten von Platten hergestellt werden, etwa extrudiertem Polystyrol, Polyurethan-Schaum, expandiertem Polystyrol, Karton, laminiertem Polyurethan-Schaum und laminiertem expandiertem Polystyrol.

Revendications

1. Un système de régulation de la température d'un conteneur de transport destiné à une utilisation dans un conteneur de transport possédant une base et au moins une paroi latérale et un capot, le système de régulation de la température comprenant au moins un manchon (50) pliable entre un état déplié et un état compressé et possédant un premier et un deuxième plan principal et au moins un bloc de régulation de la température (53), le manchon pouvant être rattaché avant la première utilisation le long d'un de ses plans principaux à un plan principal d'une paroi intérieure du conteneur, chaque manchon étant utilisable dans un état compressé de façon à permettre au conteneur d'être replié et dans un état déplié de façon à contenir un bloc de régulation de la température destiné à maintenir une température d'une atmosphère à l'intérieur du conteneur lorsqu'il est fermé grâce à un transfert thermique avec l'atmosphère du conteneur, et de façon à empêcher un contact avec tout produit.
2. Un système de régulation de la température selon la Revendication 1, où le manchon (50) comprend un moyen d'espacement (52, 52') configuré de façon à déterminer une distance minimale entre un produit à l'intérieur d'un conteneur et un bloc de régulation de la température à l'intérieur du manchon.
3. Un système de régulation de la température selon la Revendication 1 ou 2, où le moyen d'espacement comprend un élément parmi carton, un espace d'air défini par un carton (52) ou un plastique, et une couche d'isolation en plastique (52').
4. Un système de régulation de la température selon l'une quelconque des Revendications 1 à 3, où le manchon comprend un matériau en feuille configuré de façon à définir une ouverture pour le placement d'un bloc de régulation de la température de forme standard.
5. Un système de régulation de la température selon

l'une quelconque des Revendications 1 à 4, où le manchon possède des ouvertures (55) dans une paroi de celui-ci, permettant ainsi aux contenus du manchon d'être visibles.

5

10

15

20

25

30

35

40

45

50

55

6. Un système de régulation de la température selon l'une quelconque des Revendications 1 à 5, où le manchon possède, en utilisation, une partie supérieure (51) et une partie inférieure (59), la largeur interne (w_1) de la partie supérieure étant dimensionnée de façon à permettre le passage d'un bloc de régulation de la température dans l'ouverture du manchon, la largeur interne (w_2) de l'ouverture au niveau de la partie inférieure étant inférieure à la largeur d'un bloc de régulation de la température.
7. Un système de régulation de la température selon l'une quelconque des Revendications 1 à 6, où le bloc de régulation de la température (53) est fabriqué à partir d'un matériau en plastique à feuille et est rempli d'un matériau sous forme de gel ou d'un matériau sous forme de carton et est rempli d'un matériau sous forme de gel à l'intérieur d'un sac en plastique, ledit matériau sous forme de gel possédant une capacité thermique élevée.
8. Un conteneur de transport sous forme de paquet plat (20) avec un système de régulation de la température, le conteneur de transport sous forme de paquet plat possédant une base et au moins une paroi latérale et un capot, conçu de façon à transporter un produit placé sur la base, ledit système de régulation de la température comprenant au moins un manchon pliable entre un état déplié et un état compressé et possédant un premier et un deuxième plan principal et au moins un bloc de régulation de la température, un des plans principaux du manchon étant rattaché à une partie paroi du conteneur, où, le manchon est conçu de façon à :

dans un état compressé, permettre au conteneur d'être replié et, dans un état déplié, contenir un bloc de régulation de la température destiné à maintenir une température d'une atmosphère à l'intérieur du conteneur lorsqu'il est fermé grâce à un transfert thermique avec l'atmosphère du conteneur, et, empêcher un contact du bloc de régulation de la température avec tout produit.
9. Un conteneur de transport selon la Revendication 8, où le moyen d'espacement comprend un élément parmi carton, un espace d'air défini par un carton ou un plastique, et une couche d'isolation en plastique.
10. Un conteneur de transport selon la Revendication 8 ou 9, où le manchon comprend un matériau en feuille configuré de façon à définir une ouverture pour le

placement d'un récipient de liquide réfrigérant de forme standard.

11. Un conteneur de transport selon l'une quelconque des Revendications 8 à 10, où le manchon possède des ouvertures (55) dans une paroi de celui-ci, ce qui permet aux contenus du manchon d'être visibles. 5
12. Un conteneur de transport selon l'une quelconque des Revendications 8 à 11, où le manchon possède, en utilisation, une partie supérieure (51) et une partie inférieure (59), la largeur interne (w_1) de la partie supérieure étant dimensionnée de façon à permettre le passage d'un bloc de régulation de la température dans l'ouverture de l'enveloppe, la largeur interne (w_2) de l'ouverture au niveau de la partie inférieure étant inférieure à la largeur d'un bloc de régulation de la température. 10
15
13. Un conteneur de transport selon l'une quelconque des Revendications 8 à 12, où le bloc de régulation de la température est fabriqué à partir d'un matériau en plastique et est rempli d'un matériau sous forme de gel ou sous forme de carton et est rempli d'un matériau sous forme de gel à l'intérieur d'un sac en plastique, ledit matériau sous forme de gel possédant une capacité thermique élevée 20
25
14. Un conteneur de transport selon l'une quelconque des Revendications 8 à 13, où les panneaux isolants sont fabriqués à partir d'un ou plusieurs types de panneau comprenant polystyrène extrudé, mousse de polyuréthane, polystyrène expansé, carton, mousse de polyuréthane stratifiée et polystyrène expansé stratifié. 30
35

40

45

50

55

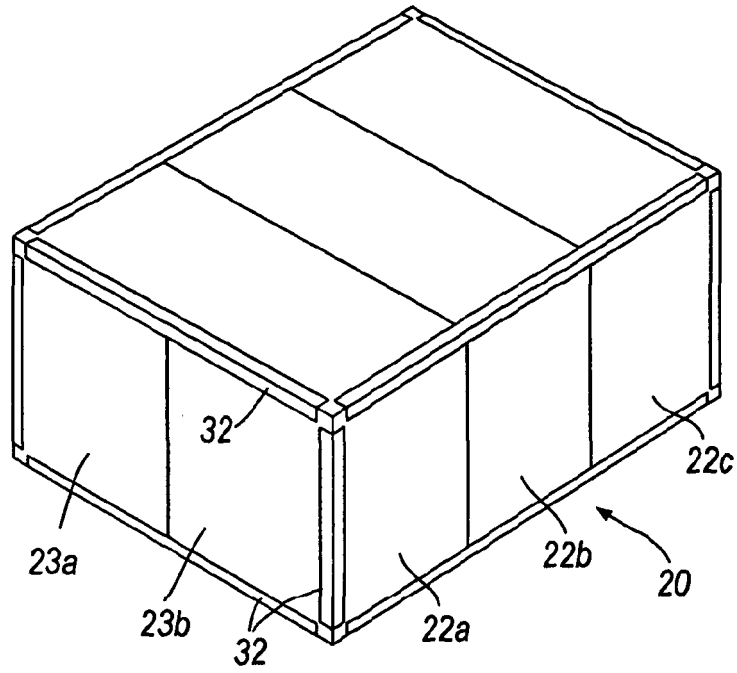

Fig. 1

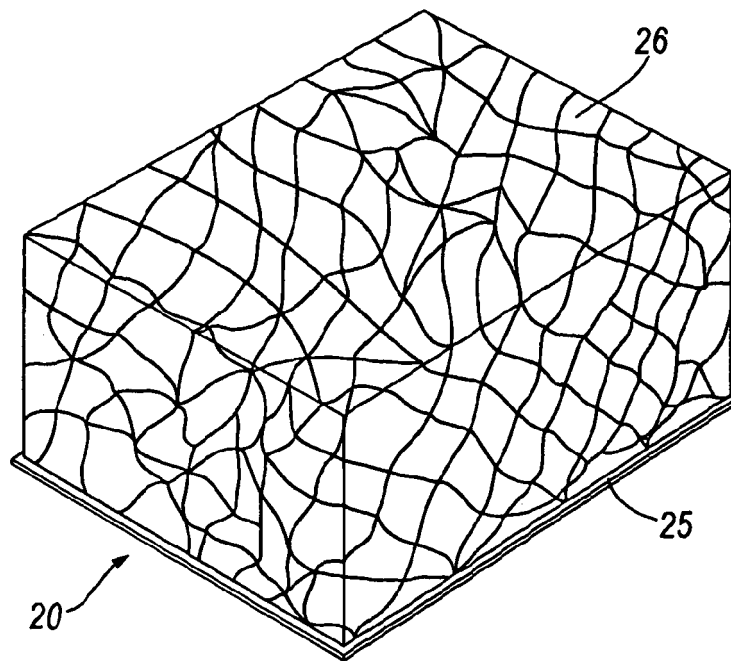

Fig. 2

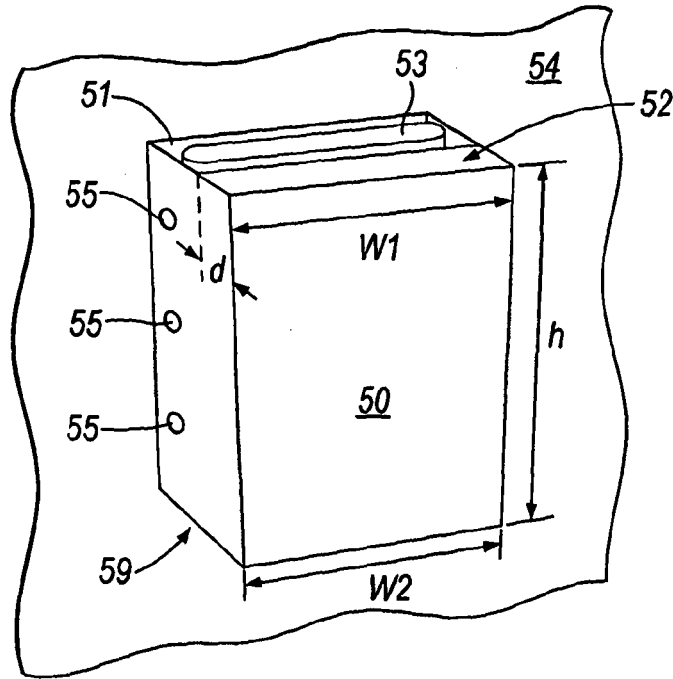

Fig. 3a

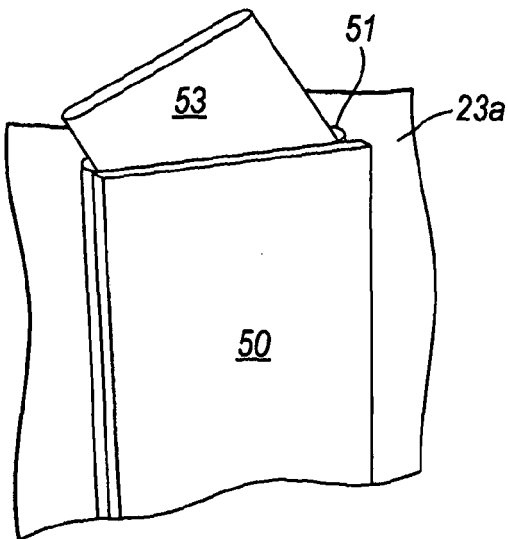

Fig. 3b

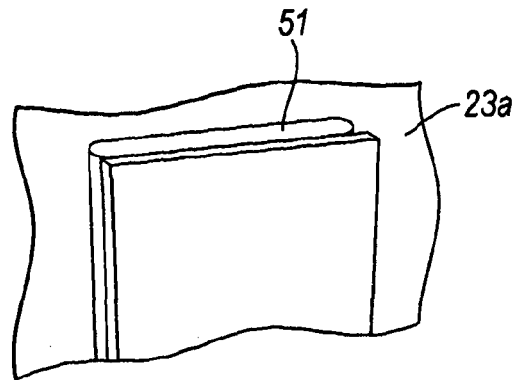

Fig. 3c

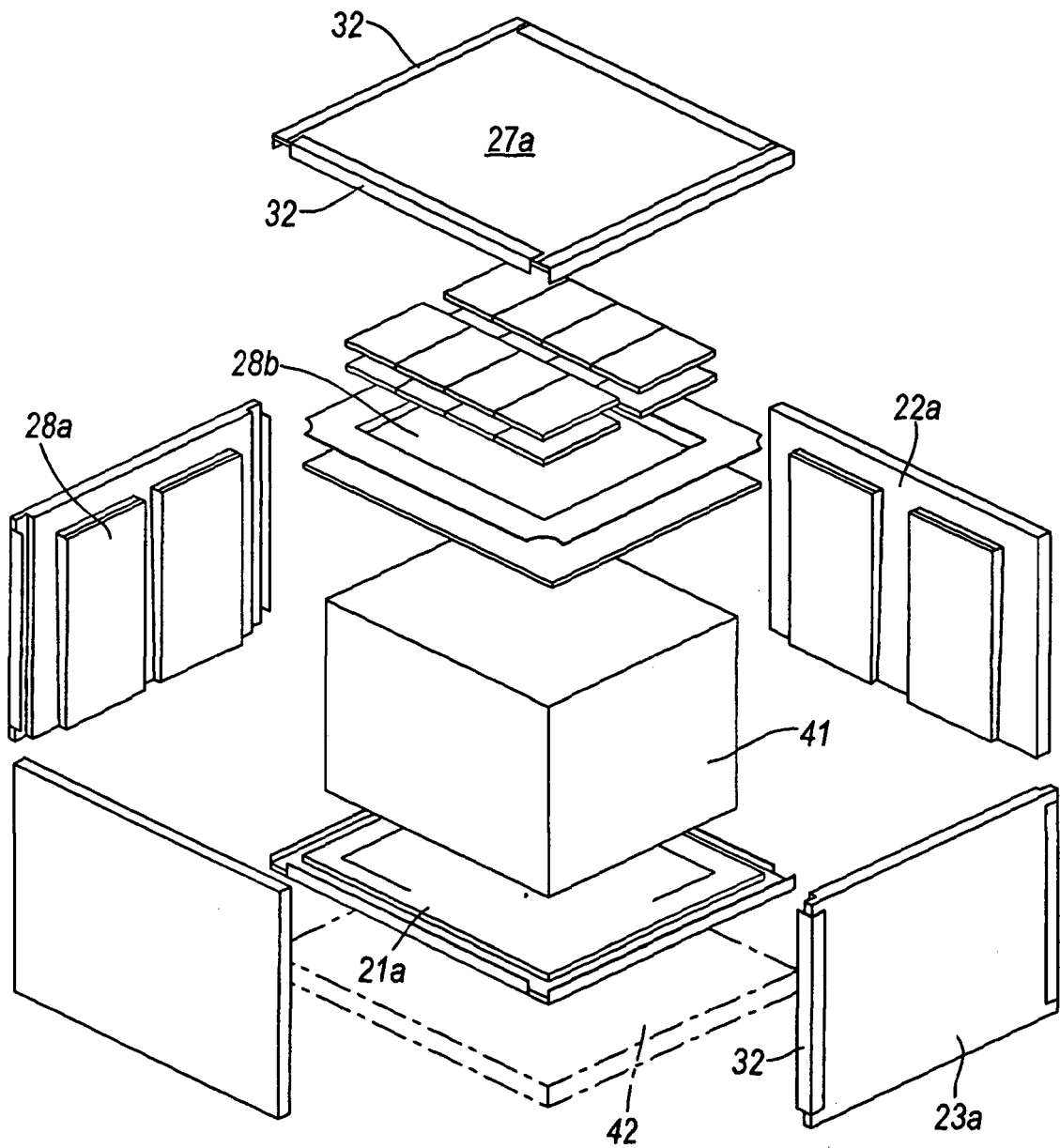

Fig.4

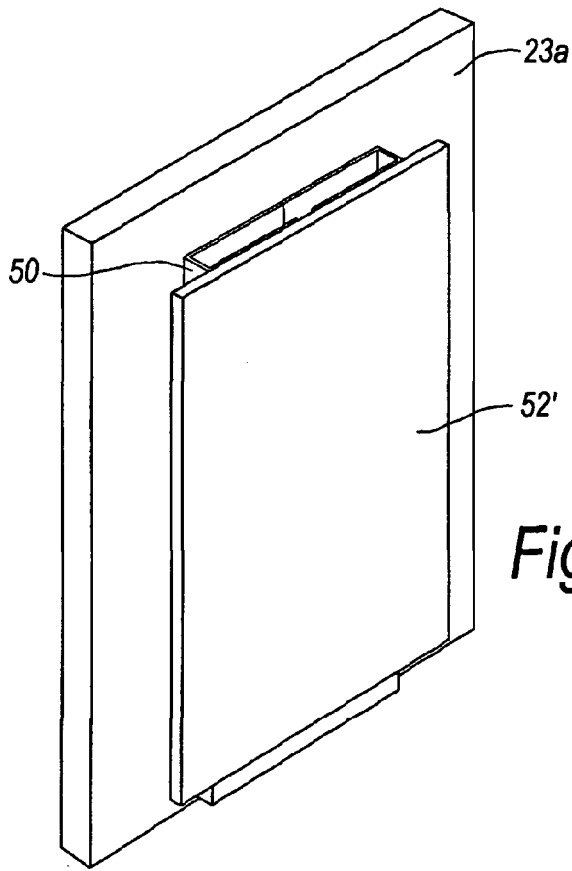

Fig. 5

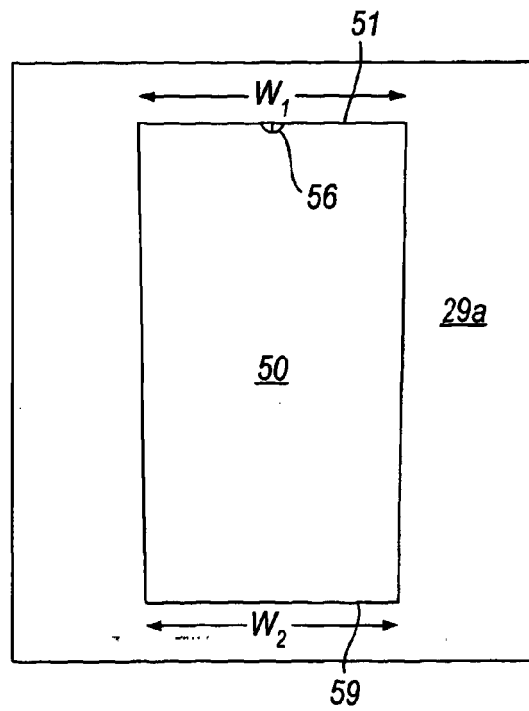

Fig. 6a

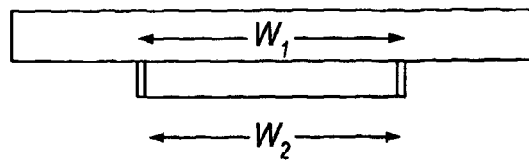

Fig. 6b

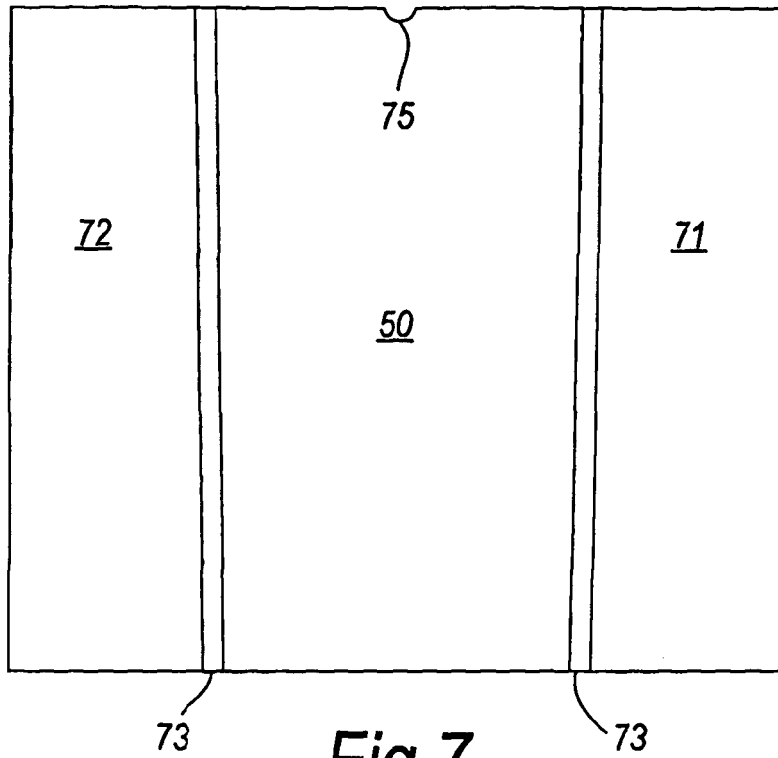

Fig. 7

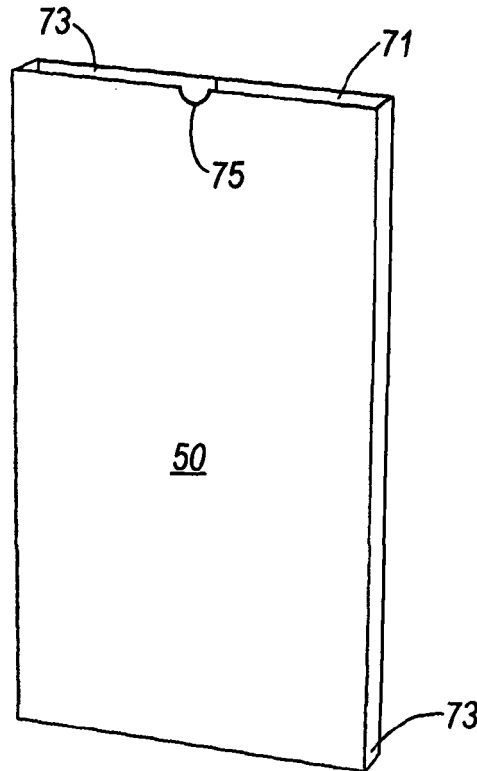

Fig. 8

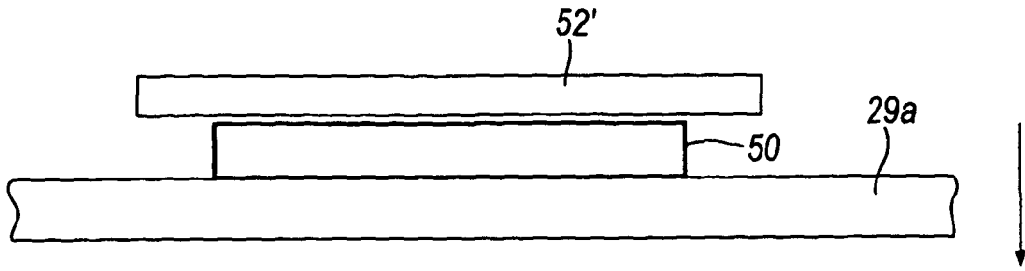

Fig. 9a

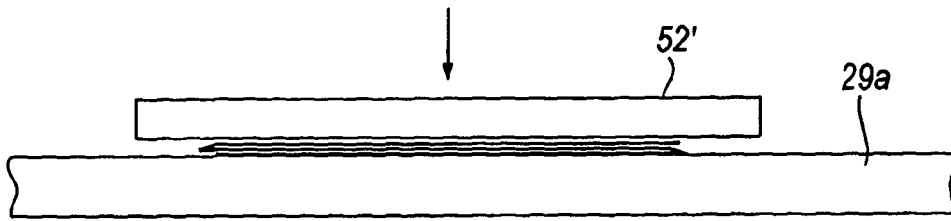

Fig. 9B

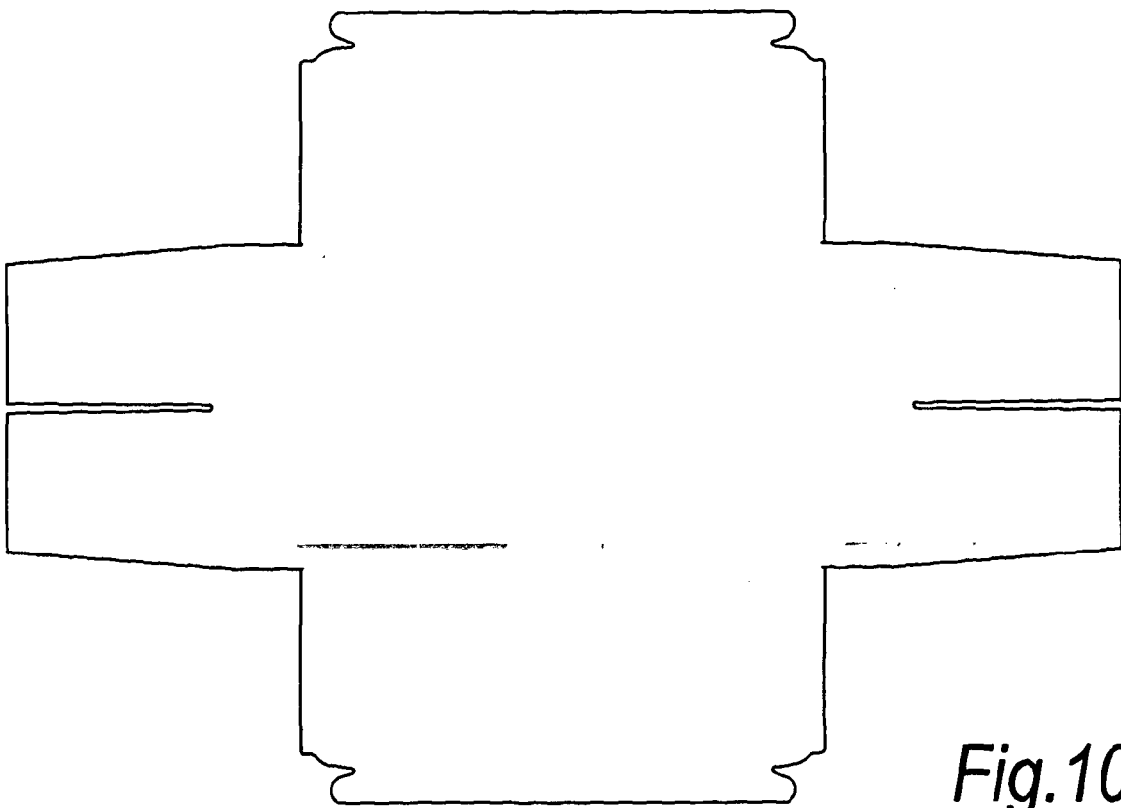

Fig. 10c

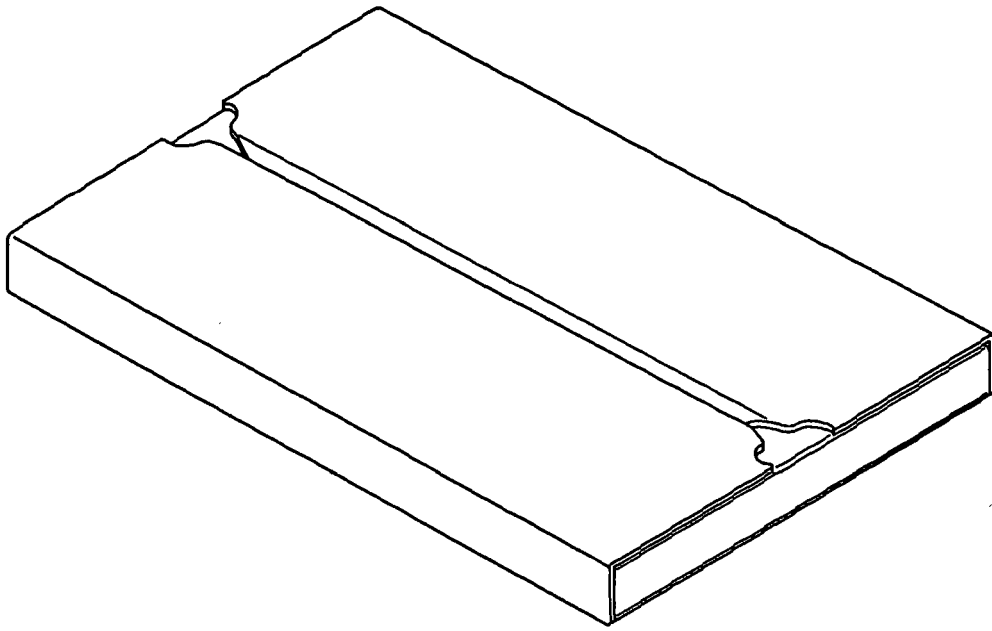

Fig. 10a

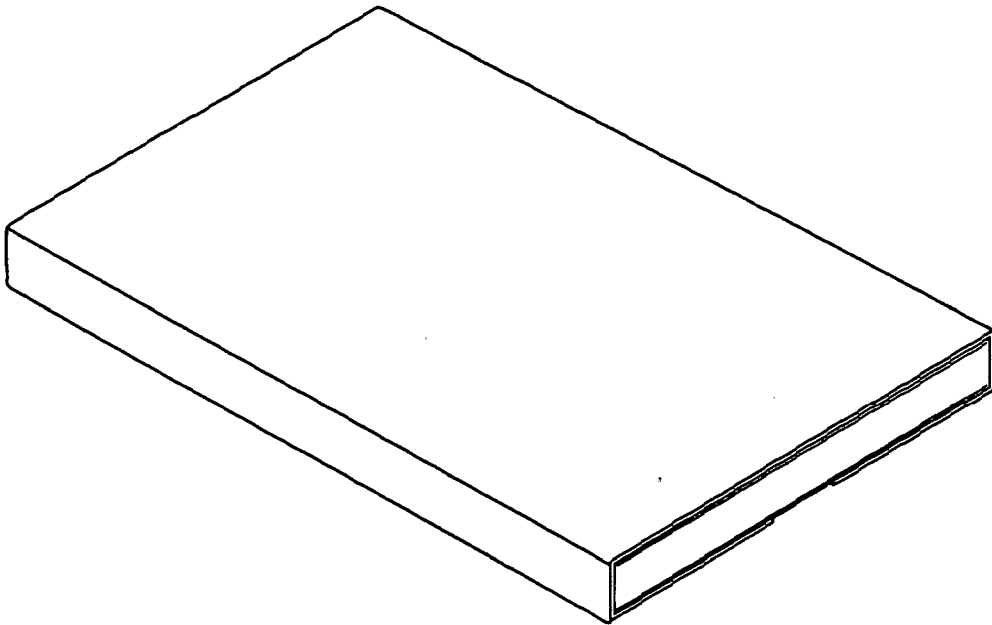

Fig. 10b

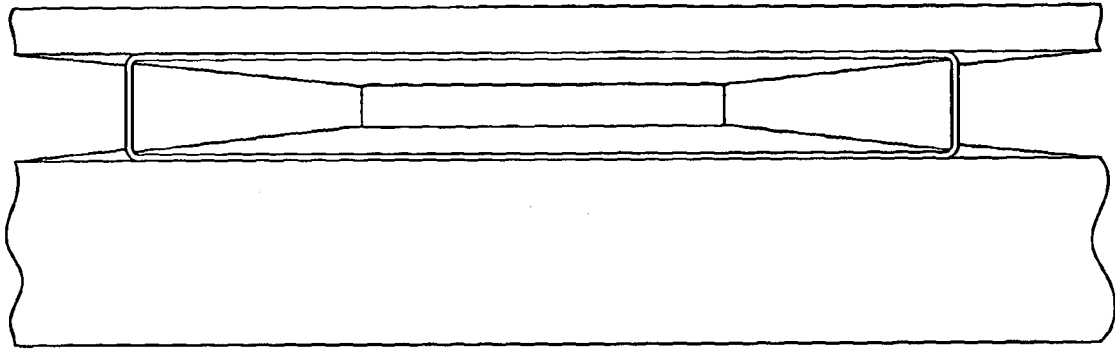

Fig.11

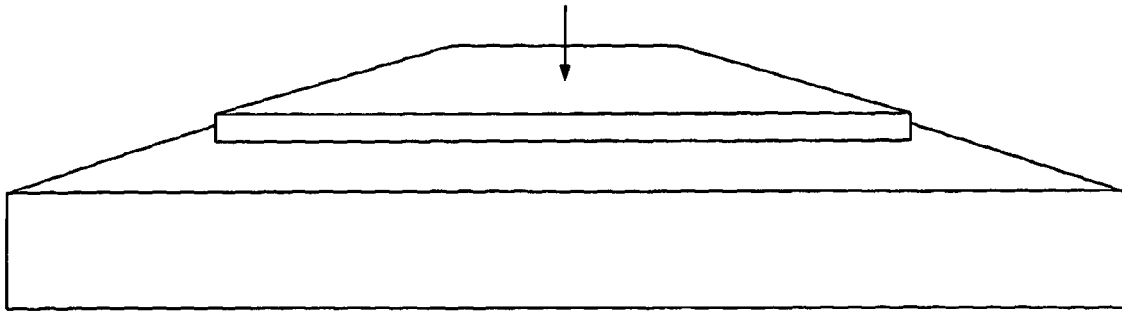

Fig.12

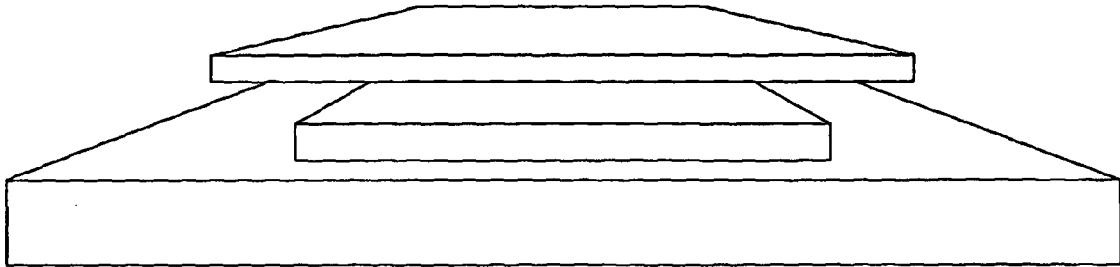

Fig. 13a

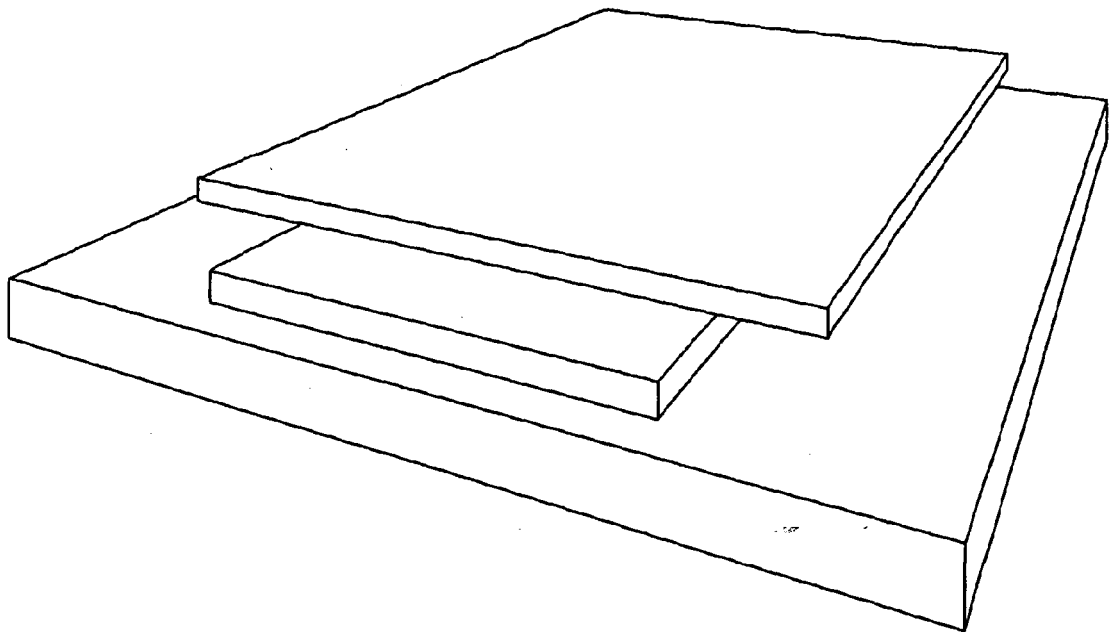

Fig. 13b

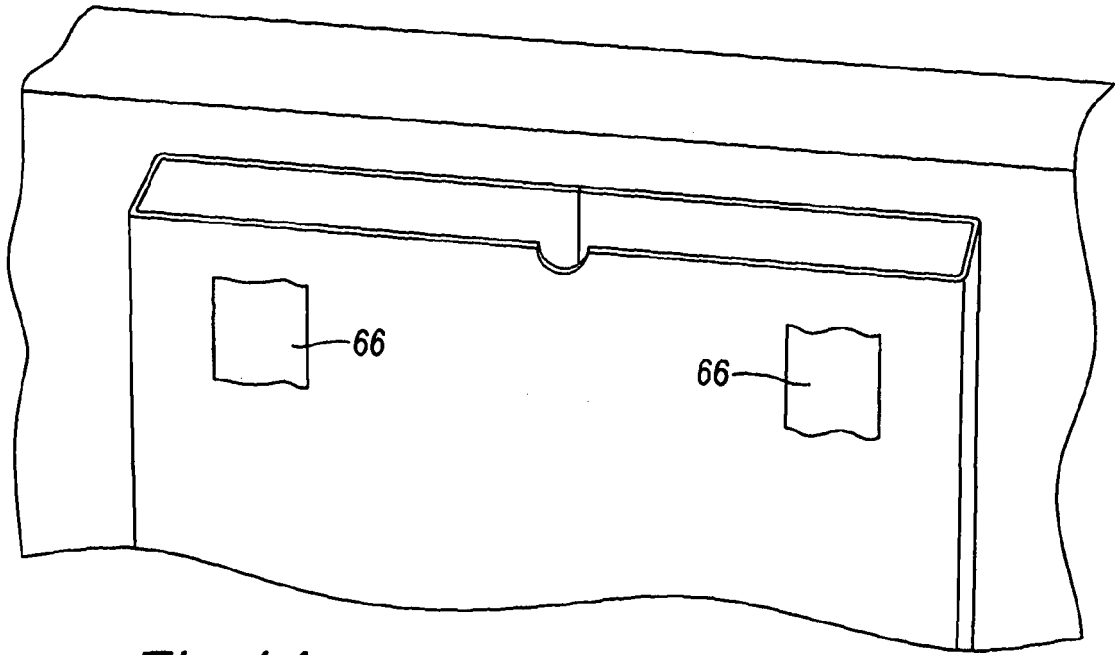

Fig. 14

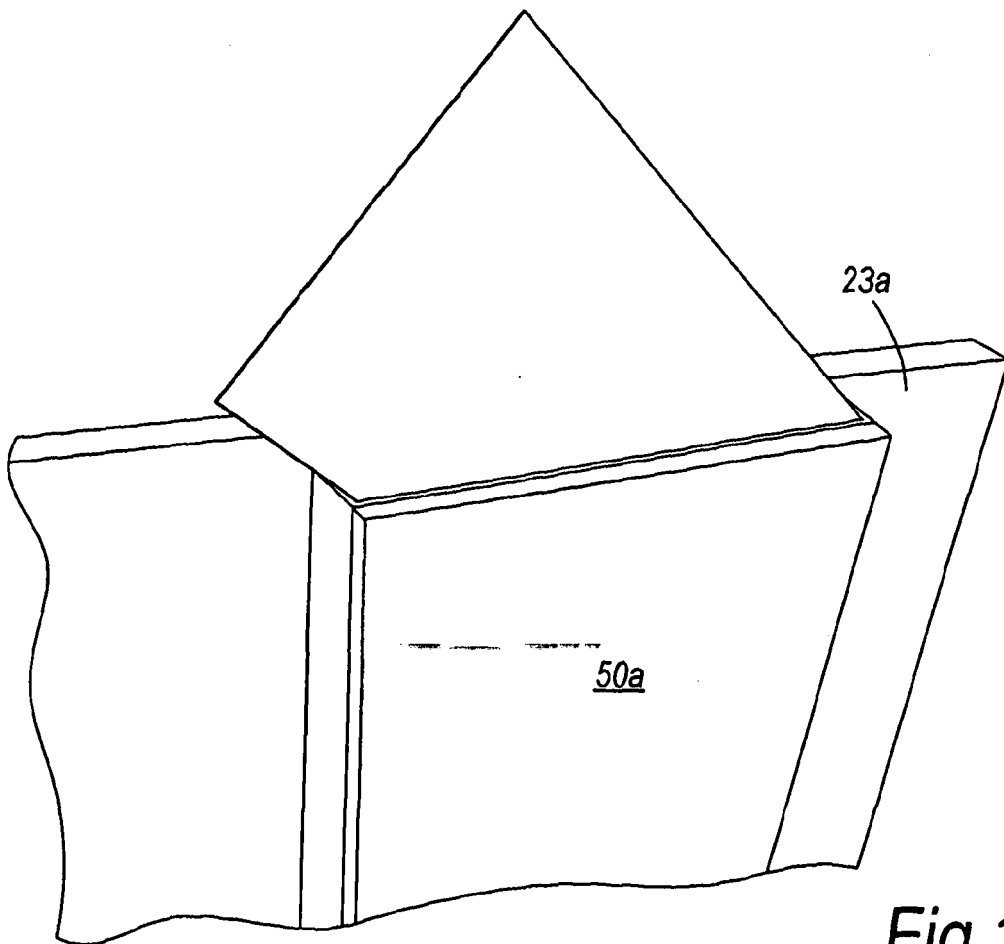

Fig. 15

REFERENCES CITED IN THE DESCRIPTION

This list of references cited by the applicant is for the reader's convenience only. It does not form part of the European patent document. Even though great care has been taken in compiling the references, errors or omissions cannot be excluded and the EPO disclaims all liability in this regard.

Patent documents cited in the description

- CN 20136863 [0006]
- KR 20080100401 [0007]
- GB 2459392 A [0021] [0024]