



(11) **EP 2 436 341 A8**

(12) **CORRECTED EUROPEAN PATENT APPLICATION**

(15) Correction information:
Corrected version no 1 (W1 A1)
Corrections, see
Bibliography INID code(s) 71

(51) Int Cl.:
A61F 2/38 (2006.01) **A61F 2/30 (2006.01)**

(48) Corrigendum issued on:
09.05.2012 Bulletin 2012/19

(43) Date of publication:
04.04.2012 Bulletin 2012/14

(21) Application number: **11175834.8**

(22) Date of filing: **28.07.2011**

(84) Designated Contracting States:
AL AT BE BG CH CY CZ DE DK EE ES FI FR GB GR HR HU IE IS IT LI LT LU LV MC MK MT NL NO PL PT RO RS SE SI SK SM TR
Designated Extension States:
BA ME

(72) Inventors:
• **Wagner, Christel M**
Plymouth, Indiana 46563 (US)
• **Wyss, Joseph G**
Fort Wayne, Indiana 46814 (US)
• **Barrett, David**
Eastleigh, Southampton SO53 3PT (GB)

(30) Priority: **30.09.2010 US 894651**

(74) Representative: **Belcher, Simon James**
Urquhart-Dykes & Lord LLP
Tower North Central
Merrion Way
Leeds LS2 8PA (GB)

(71) Applicant: **DePuy Products, Inc.**
Warsaw, IN 46581 (US)

(54) **Femoral component of a knee prosthesis**

(57) An implantable orthopaedic knee prosthesis includes a femoral component that is configured to be coupled to a surgically-prepared distal femur. The femoral component has an articular side that includes a posterior femoral condyle surface. A fixation side is opposite the articular side, and it includes a posterior fixation surface that extends generally in the superior/inferior direction. The posterior fixation surface has an angled posterior cement pocket formed therein.

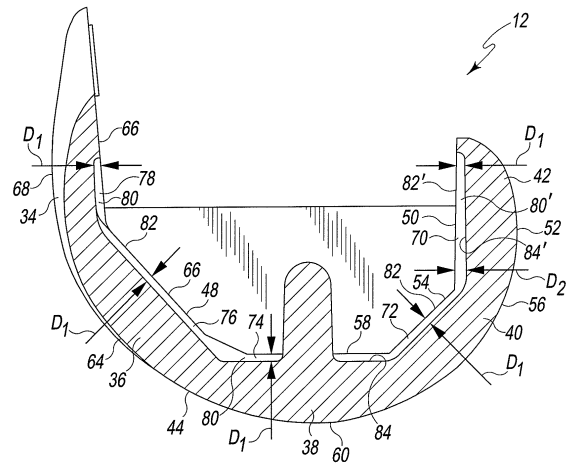

Fig. 4

EP 2 436 341 A8