

(19)



(11)

EP 2 439 366 B1

(12)

EUROPEAN PATENT SPECIFICATION

(45) Date of publication and mention of the grant of the patent:

30.12.2015 Bulletin 2015/53

(51) Int Cl.:

E05F 11/54 <small>(2006.01)</small>	E05B 65/00 <small>(2006.01)</small>
E05B 63/04 <small>(2006.01)</small>	E05B 1/00 <small>(2006.01)</small>
E05B 17/00 <small>(2006.01)</small>	F25D 23/02 <small>(2006.01)</small>

(21) Application number: **11183358.8**

(22) Date of filing: **29.09.2011**

(54) Device for opening sliding doors for cold rooms

Vorrichtung zum Öffnen von Schiebetüren für Kühlräume

Dispositif pour ouvrir des portes coulissantes pour chambres froides

(84) Designated Contracting States:

**AL AT BE BG CH CY CZ DE DK EE ES FI FR GB
GR HR HU IE IS IT LI LT LU LV MC MK MT NL NO
PL PT RO RS SE SI SK SM TR**
Designated Extension States:
BA ME

(30) Priority: **11.10.2010 IT MI20101850**

(43) Date of publication of application:
11.04.2012 Bulletin 2012/15

(73) Proprietor: **Dervet S.r.l.**
26025 Pandino (CR) (IT)

(72) Inventor: **Milanesi, Paolo**
26020 MADIGNANO (CR) (IT)

(74) Representative: **Ripamonti, Enrico**
Giambrocono & C. S.p.A.
Via Rosolino Pilo, 19/B
20129 Milano (IT)

(56) References cited:
DE-A1- 2 758 521

EP 2 439 366 B1

Note: Within nine months of the publication of the mention of the grant of the European patent in the European Patent Bulletin, any person may give notice to the European Patent Office of opposition to that patent, in accordance with the Implementing Regulations. Notice of opposition shall not be deemed to have been filed until the opposition fee has been paid. (Art. 99(1) European Patent Convention).

Description

[0001] The present invention relates to a device enabling the door panel of a cold room sliding door to be released from its closed position.

[0002] As known to the expert of the art, doors of this type comprise a door panel sliding on guides disposed parallel to the wall in which the door aperture is provided. These door panel guides are shaped such that when the door panel is moved from its maximum open position (which leaves the entire aperture uncovered) to its closed position, just before it reaches this latter position the door panel is made to approach the wall and floor such that these press against the gaskets, carried by the door panel, which ensure the seal.

[0003] These doors are provided with a device which enables the door to be easily released, and which levers against one side of the door aperture (normally against the relative upright of the frame defining the door aperture) so as to withdraw the door panel from this upright by overcoming both the opposing resistance and friction, also exerted by said seal gasket when in its compressed state.

[0004] As also known to the expert of the art, a known device of this type comprises:

- a bush having a length substantially equal to the door panel thickness in order to be able to be incorporated into the door panel with its axis perpendicular thereto, the bush laterally presenting at least two opposing through slots, the axes of which must have their inclination opposite the bush axis, with the inclination of the slot axes in a door with rightward opening being opposite that of a door with leftward opening;
- a central shaft coaxially inserted into the bush such that it can be rotated about its axis and be moved along said axis, and of which the length enables it to project from both sides of the door panel;
- a number of pawls projecting radially from said central shaft equal to the number of slots provided in said bush, each pawl engaging in a relative slot;
- an external handle, consisting of a rather lengthy bar (even more than 50 cm) fixed to the outer end of the central shaft and extending radially from it (normally disposed vertically downwards when the door is closed);
- an internal handle, consisting of a lever fixed to the shaft and which, with the door closed, extends both upwards and downwards from the central shaft (which forms its fulcrum), the free end of its upper part being deviated to the left if the door is of rightward opening type and to the right if of leftward opening type, such that with the door closed, this free end rests against the vertical upright of the door frame;
- a preloaded helical spring, mounted coaxially on the central shaft such that one end rests on a relative shoulder provided inside the bush, while the other end of the spring rests on a collar provided on the

central shaft, the spring maintaining the shaft-handle assembly in a position withdrawn outward from the door panel when this latter has been released, so as not to interfere with said gaskets when the door is completely opened.

[0005] Essentially, by simply rotating the external handle anticlockwise if the sliding door opens rightwards or clockwise if it opens leftwards, and consequently causing the internal handle to rotate and act as a lever with its upper end acting against the door frame, the aforesaid device releases the door panel when in its closed position. Once released, the door panel can be manually moved until the door is completely open.

[0006] In contrast, after then manually sliding the door panel into its closed position, as the shaft-handle assembly (because of the action of said helical spring) is still in its rotated and withdrawn position because of having previously opened the door, the upper end of the internal handle rests against the relative upright of the door frame before the door panel arrives in its completely closed position. Completing closure of the door panel causes the internal handle to rotate (viewing from the outside) and to move inwards, against the action of the helical spring, until the shaft-handle assembly assumes the already described closed position.

[0007] It has already been stated that in the case of a door with leftward opening, the bush must have its slot inclination opposite that of a bush for rightward opening doors. The aforesaid internal handle is also different (specular) in the two cases, although it can be easily produced such as to be able to be fixed to the central shaft in a determined position compatible for example with rightward opening and also in an inverted position to be also compatible with leftward opening.

[0008] It should also be noted that door panels for cold rooms can have different thicknesses (in particular thicknesses of 70, 80, 90, 100 and exceptionally 120 mm), so that the current manufacturers of devices of this type have to produce bushes of the corresponding length (bushes of five different lengths in the specific case of the aforesaid thicknesses), but for each bush length two bushes have to be produced having opposingly inclined slots, for rightward opening and leftward opening doors. Hence a cold room sliding door manufacturer must currently stock ten different bush types. An example of such a device can be seen in DE 27 58 521, disclosing the features of the preamble of claim 1.

[0009] An object of the present invention is therefore to provide a device of the aforesaid type which is adaptable to all or at least a part of the currently required door panel thicknesses for doors of this type.

[0010] This object is attained by the device of the present invention defined by claim 1, comprising:

- a bush incorporated into the thickness of the door panel and fixed thereto such that its axis is perpendicular to the door panel;

- a central shaft coaxially inserted into the bush to be able both to rotate about the axis of this latter and to move along said axis;
- means for guiding the movement and rotation of the central shaft, which enable it to rotate in the direction compatible with the door opening direction;
- elastic means to bring the central shaft into a position withdrawn outwards from the door panel when left free to move coaxially;
- external means for rotating the central shaft;
- internal means for rotating the central shaft and provided with a striker adapted to come into contact with a fixed point (for example the relative side of the door frame) such that, following forced rotation, achieved by said external or internal means, of the central shaft in the direction compatible with the door opening direction, a consequent forcing of said striker against said fixed point is obtained, such as to cause release of the door,

whereby the bush has a length less than the thickness of all or at least part of the door panels of such doors, a ring cap being provided coupleable coaxially to the bush such that the bush-ring cap assembly has a length adapted to the thickness of the specific door panel.

[0011] According to the present invention, the coupling between the ring cap and bush is of "telescopic" type, means (in particular screws) being provided to fix the ring cap to the bush such as to obtain the required length of the bush-ring cap assembly.

[0012] Said guide means for the central shaft comprise two opposing guides provided in the inner wall of the bush, the guides having an inclination to the bush axis which is compatible with the door opening direction, these guides cooperating for this purpose with respective pawls projecting radially from the central shaft.

[0013] Another object of the present invention is to provide a device of the aforesaid type which besides being adaptable to all or at least part of the commercially required door panel thicknesses is usable for both rightward opening and leftward opening sliding doors.

[0014] This object is also attained by a preferred embodiment of the device of the present invention in which, provided in one and the same bush, there are both first guide means for the central shaft which enable it to rotate in the direction corresponding to a door with a determined opening direction, and second guide means which enable the central shaft to rotate in the opposite direction corresponding to the opening direction of a door with opposite opening direction.

[0015] This can be easily achieved for example by providing in the bush interior two first opposing guides which extend with an inclination to the bush axis which is compatible with a door having a determined opening direction, and two second opposing guide means which extend with an inclination compatible with the other opening direction, with the result that the first guides have the opposite inclination to the two second guides.

[0016] In particular, the guide means can have a fixed limit stop corresponding to the angular position of the central shaft relative to the released door panel, the other limit stop being removable and positionable, depending on whether the door has rightward opening or leftward opening, to operate as a limit stop for rightward opening or leftward opening guide means respectively.

[0017] The invention will be more easily understood from the following description of one embodiment thereof given by way of example. In this description reference is made to the accompanying drawings, in which:

Figure 1 is an exploded perspective view of a device according to the present invention;

Figure 2 is a second exploded perspective view thereof, but from another viewpoint;

Figure 3 is a rear view, with reference to Figure 1, of the bush shown in that figure;

Figure 4 is a section therethrough taken on the line 4-4 of Figure 3;

Figure 5 is a section therethrough taken on the line 5-5 of Figure 3;

Figure 6 is a rear view, again with reference to Figure 1, of the ring cap visible in that figure;

Figure 7 is a section therethrough, taken on the line 7-7 of Figure 6;

Figure 8 shows in the right part an enlarged plan view from above of the central shaft visible in Figure 1, and in the left part a horizontal coaxial section therethrough;

Figure 9 is a partly sectioned lateral view thereof in the direction of the arrow 9 of Figure 8;

Figure 10 is a perspective view of the external handle as it appears once applied to a cold room sliding door panel (shown partially) with leftward opening;

Figure 11 is a perspective view of the internal handle applied to the same door panel.

[0018] As can be seen in Figures 1 and 2, the device shown therein, indicated overall by 10, comprises a bush 12, shown in greater detail in Figures 3-5, and a ring cap 14 to be mounted coaxially on the bush 12 and fixed thereto by (in the specific illustrated case) three screws insertable through corresponding through holes provided in the ring cap 14, the screws 16 being insertable through relative holes 17 and screwed into threaded holes 18 provided in the bush 12. As can be seen from Figures 1 and 2, an entire set of holes 18 is provided to enable, by means of a type of telescopic joint, the overall length of the bush-ring cap assembly to be adjusted to adapt it to the thickness of the specific sliding door panel to which the device 10 is to be applied. It has already been stated, by way of example, that doors are currently available having thicknesses of 70, 80, 90, 100, 120 mm, so that the position of the holes 18 on the bush 12 in the axial direction is chosen such that the length of the bush 12-ring cap 14 assembly is compatible with said door panel thicknesses. In fact, by virtue of the device of the present

invention, doors can be formed having door panels with a larger range of thicknesses, i.e. thicknesses much closer to specific requirements (for example a series of thicknesses differing from each other by 5 mm).

[0019] The device 10 also comprises a central shaft 20 (Figures 1, 2, 8 and 9) inserted coaxially into the bush 12-ring cap 14 assembly such that it can rotate about its own axis, but also translate in both directions along this axis. As best seen in Figures 8 and 9, the central shaft 20 presents a diametrical through hole 22 arranged to receive a diametrical pin 24 the two ends of which project equally from the central shaft 20 to form two respective pawls (indicated for simplicity by the same reference numeral as the pin 24) which cooperate with corresponding guides (described below) formed by recesses provided in the interior of the bush 12. These guides consist essentially of one of the edges of a relative recess, this edge being inclined to the axis of the bush 12. One of the two guides, indicated by 26, is visible in Figure 4. The relative pawl 24 rests against this guide. It should be noted that the guide 26 is suitable for a sliding door with leftward opening. The other pawl 24 is guided by a similar edge of a corresponding recess (not visible in the figures because it is opposite that of the guide 26, it being inverted to be able to perform the same function when the central shaft 20 is rotated in the anticlockwise direction with reference to Figure 1).

[0020] It should be noted that the same bush 12 also presents at the same time a second pair of opposite guides suitable for a rightward opening door. The guides of this second pair are disposed rotated through 90° to those of the first pair and have opposite inclination. A guide of the second pair, indicated by 27, is visible in Figure 5.

[0021] The device 10 also comprises a helical spring 28 which when the device 10 is mounted is preloaded and rests with one end on a collar 30 of the central shaft 20 whereas its other end rests against the step 32 in the interior of the bush 12.

[0022] Once a door, for example with leftward opening, has been released, the spring 28 causes the central shaft 20 to withdraw outwards until the two pawls 24 abut against the two stop elements 36 fixable to the bush 12, this latter presenting for this purpose two relative seats 38 (also see Figure 3). The arched arm of the stop elements 36 enables the movement of the relative pawl 24 along the guide 26 to be also limited from the other side. It should be noted that by simply inverting the stop elements 36, these no longer interfere with the pawls 24 of the first pair, but instead interfere with the said pawls 24 when cooperating with the second pair of guides (those for a leftward opening door) Consequently, by simply orientating the bush 12 angularly in a suitable manner and fixing the stop elements 36 to the bush 12 in accordance with that of their two possible positions which corresponds to this orientation, the device 10 can be adapted to a door with rightward opening rather than with leftward opening.

[0023] From Figures 1 and 2 it can be seen that the device 10 also comprises two covers 40 and 42 positioned on the inside of the door panel, which are used to fix the bush 12-ring cap 14 assembly to the door panel, and also an external handle 44 and an internal handle 46. The external handle 44 is fixed to one end of the central shaft 20 by simply inserting its near end into the dead hole 48 provided in the central shaft 20, to then lock it in position with a screw 50, whereas the internal handle 46 is fixed to the central shaft 20 by a form fit (not visible completely, but of conventional type) and two screws (of which for simplicity only one, indicated by 52, is shown in Figures 1 and 2). It can be seen from Figure 1 that the internal handle 46 is essentially a lever with its fulcrum corresponding to the axis of the central shaft 20, there also being present (also see Figure 11) a hammer head 54 arranged to abut against the relative upright (not shown) of the frame bounding the door, whether rightward opening or leftward opening. It can also be seen that the internal handle 46 has a rectangular cross-section with its minor sides parallel to the axis of the central shaft 20, in order that the thickness of this handle in the direction perpendicular to the door panel is not such as to interfere, during door opening, with the frame of this latter.

[0024] The operation of the device 10 is also apparent to an expert of the art from the foregoing. It will however be briefly described for greater clarity with reference to a leftward opening door, the operation of a rightward opening door being consequently evident.

[0025] When the door is closed, the external handle 44 and internal handle 46 lie in a vertical position with the left end of the hammer head 54 close to the right upright (not shown) of the door frame (or other suitable fixed point). In this situation the pawls 24 rest in the groove 34 (Figure 4) and the spring 28 is in its minimum compression condition.

[0026] To release the door from the outside the external handle 44 has to be rotated clockwise, this causing the door panel to move towards the left and, because of the shape of the relative guide, to withdraw such that it can be opened without the door panel seal gaskets interfering with the door frame. By virtue of the guides 26, rotating the handle 44 causes the pawls 24 to move along the relative guides 26 until the pawls 24 become positioned against the limit stops 36. If the handle 44 is left free at this point, the action of the spring 28 returns the pawls 24 into the corresponding grooves 34, the handle 44 consequently returning into the vertical position (withdrawn position, so that it does not interfere with the door frame when the door is opened completely, such that the entire door aperture is usable).

[0027] To close the door, the door panel needs merely to be returned to its closed position.

[0028] In conclusion, by virtue of the device of the present invention, only one set of pieces needs to be stocked for the device 10, and in particular only one bush 12 for an entire series of door panel thickness for the cold

room sliding door, whether the door is rightward opening or leftward opening.

Claims

1. A device (10) for releasing a cold room sliding door from its closed position, comprising:

- a bush (12) incorporated into the thickness of the door panel (56) and fixed to the door panel (56) such that its axis is perpendicular to this latter (56);

- a central shaft (20) coaxially and rotatably inserted into the bush (12); the central shaft (20) is able both to rotate about the axis of the bush (12) and to move along said axis; whereby means (26, 24; 27, 24) for guiding the movement and rotation of the central shaft (20), which enable it to rotate in the direction compatible with the door opening direction are provided; wherein the guide means for the central shaft (20) comprise two opposing guides (26; 27) provided in the inner wall of the bush (12), and respective pawls (24) projecting radially from the central shaft (20) and cooperating with the guides (26; 27), the guides (26; 27) having an inclination to the bush (12) axis which is compatible with the door opening direction; whereby a preloaded helical spring (28) is resting with one end on a collar (30) of the central shaft (20) whereas its other end rests against a step (32) in the interior of the bush (12); and whereby

- external means (44), e.g. external handle, for rotating the central shaft (20) are provided;

- internal means (46), e.g. internal handle, for rotating the central shaft (20) are provided and said internal means are provided with a striker (54) adapted to come into contact with a fixed point, e.g. a door frame upright, such that, following forced rotation, achieved by said external means (44) or internal means (46), of the central shaft in the direction compatible with the door opening direction, a consequent forcing of said striker (54) against said fixed point is obtained, such as to cause release of the door;

characterised in that

the bush (12) has a length less than the thickness of all or at least part of the door panels (56) of such doors, a ring cap (14) being provided coupleable coaxially to the bush (12) such that the bush (12)-ring cap (14) assembly has a length adapted to the thickness of the specific door panel (56) wherein the coupling between the ring cap (14) and bush (12) is of "telescopic" type, means (16) being provided to fix the ring cap (14) to the bush (12) such as to obtain the required length of the bush (12)-ring cap (14)

assembly.

2. A device as claimed in claim 1, wherein provided in one and the same bush (12) there are both first guide means (26, 24) for the central shaft (20) which enable it to rotate in the direction corresponding to a door with a determined opening direction, and second guide means (27, 24) which enable the central shaft (20) to rotate in the opposite direction, corresponding to the opening direction of a door with opposite opening direction.
3. A device as claimed in claim 2, wherein the first and second guide means for the central shaft (20) comprise respectively two first guides (26) and two second guides (27) provided in the inner wall of the bush (12), the angular position of the second two guides (27) being rotated through 90° to those of the first two guides (26).
4. A device as claimed in claim 3, wherein the guides (26; 27) have a fixed limit stop (34; 35) corresponding to the angular position of the central shaft (20) relative to the released door panel (56), the other limit stop (36) being removable and positionable, according to whether the door has rightward opening or leftward opening, to operate as a limit stop for rightward opening guide means (27, 24) or leftward opening guide means (26, 24) respectively.
5. A device as claimed in claim 1, wherein the external means and the internal means for rotating the central shaft (20) comprise respective manually operable levers (44, 46).
6. A device as claimed in claim 5, wherein the internal lever (46) is pivoted at an intermediate point thereof and fixed at that point to the central shaft (20), that end of the internal lever (46) opposite the gripping end presenting a striker (54) of hammer head shape intended to come into contact with the fixed striker point, on one side or the other, depending on the door opening direction.

Patentansprüche

1. Vorrichtung (10) zur Auslösung einer Schiebetür für Kühlraum aus ihrer Schließstellung, umfassend:

- eine in der Dicke der Türfüllung (56) eingebaute Buchse (12), die an der Türfüllung (56) so befestigt ist, dass ihre Achse senkrecht dazu (56) verläuft;

- eine Zentralwelle (20), die koaxial und drehbar in der Buchse (12) eingeschlossen ist; die Zentralwelle (20) kann um die Achse der Buchse (12) drehen und sich der genannten Achse ent-

- lang bewegen; wobei Mittel (26, 24; 27, 24) zur Führung der Bewegung und die Umdrehung der Zentralwelle (20) vorhanden sind, um deren Umdrehung in einer der Türöffnungsrichtung entsprechenden Richtung zu erlauben; worin die Führungsmittel der Zentralwelle (20) zwei entgegengesetzten Führungen (26; 27) in der Innenwand der Buchse (12), sowie entsprechende aus der Zentralwelle (20) radial hervorragende und mit den Führungen (26; 27) zusammenwirkende Klauen (24), umfassen, wobei die Führungen (26; 27) einen Neigungswinkel zu der Achse der Buchse (12) haben, der der Türöffnungsrichtung entspricht; wobei eine vorge-ladene Schraubenfeder (28) mit einem Ende auf einem Bundring (30) der Zentralwelle (20) und mit dem anderen Ende gegen eine Stufe (32) innerhalb der Buchse (12) liegt; und wobei
- äußere Mittel (44), zum Beispiel ein äußerer Griff, sind zur Umdrehung der Zentralwelle (20) vorhanden;
 - innere Mittel (46), zum Beispiel ein innerer Griff, sind zur Umdrehung der Zentralwelle (20) vorhanden und sind mit einem Schlaggerät (54) versehen, das geeignet ist, um mit einem Festpunkt, zum Beispiel mit einer Stütze des Türrahmens, in Berührung zu kommen, so dass, nach der gezwungenen Umdrehung der Zentralwelle (20) durch die genannten äußeren Mittel (44) oder inneren Mittel (46) in einer der Türöffnungsrichtung entsprechenden Richtung, das Schlaggerät (54) gegen den genannten Festpunkt gezwungen ist, so dass die Tür wird ausgelöst; **dadurch gekennzeichnet, dass** die Buchse (12) eine Länge hat, die weniger ist als die Dicke der gesamten Türfüllungen (56) oder mindestens eines Teils davon, wobei eine Ringkappe (14) vorhanden ist, um koaxial mit der Buchse (12) verbunden zu werden, so dass die aus der Buchse (12) und aus der Ringkappe (14) bestehende Gruppe eine der Dicke der einzigen Türfüllung (56) anpassende Länge hat, wobei die Verbindung zwischen der Ringkappe (14) und der Buchse (12) einer "teleskopischen" Art ist, worin Mittel (16) vorhanden sind, um die Ringkappe (14) mit der Buchse (12) zu verbinden, so dass die notwendige Länge der aus der Buchse (12) und aus der Ringkappe (14) bestehende Gruppe erzielt wird.
2. Vorrichtung nach Anspruch 1, worin in derselben Buchse (12) erste Führungsmittel (26, 24) für die Zentralwelle (20), um deren Umdrehung in einer einer bestimmten Türöffnungsrichtung entsprechenden Richtung zu erlauben, sowie zweite Führungsmittel (27, 24), um die Umdrehung der Zentralwelle (20) in einer einer entgegengesetzten Türöffnungsrichtung entsprechenden Richtung zu erlauben, vor-

handen sind.

3. Vorrichtung nach Anspruch 2, worin die ersten und die zweiten Führungsmittel für die Zentralwelle (20) zwei erste Führungen (26) beziehungsweise zwei zweite Führungen (27) in der Innenwand der Buchse (12) umfassen, wobei die Winkellage der zwei zweiten Führungen (27) um 90° relativ zu der Winkellage der zwei ersten Führungen (26) umgedreht ist.
4. Vorrichtung nach Anspruch 3, worin die Führungen (26; 27) einen festen Grenzanschlag (34; 35) haben, die der Winkellage der Zentralwelle (20) relativ zu der ausgelösten Türfüllung (56) entspricht, wobei der andere Grenzanschlag (36) entfernbar und je nach der Türöffnungsrichtung nach rechts oder nach links positionierbar ist, so dass er als Grenzanschlag für die Führungsmittel für die Öffnung nach rechts (27, 24) beziehungsweise nach links (26, 24) wirkt.
5. Vorrichtung nach Anspruch 1, worin die äußeren Mittel und die inneren Mittel zur Umdrehung der Zentralwelle (20) entsprechende handgesteuerte Hebel (44, 46) umfassen.
6. Vorrichtung nach Anspruch 5, worin der innere Hebel (46) an einem Mittelpunkt davon schwenkbar gelagert und an diesem Punkt mit der Zentralwelle (20) verbunden ist, wobei das der Greifextremität gegenüber liegende Ende des inneren Hebels (46) ein hammerkopfförmiges Schlaggerät (54) aufweist, das mit dem Festpunkt in Berührung kommen soll, entweder an einer oder an der anderen Seite, je nach der Türöffnungsrichtung.

Revendications

1. Dispositif (10) pour dégager une porte coulissante pour chambre froide de sa position fermée, comprenant:
- une bague (12) incorporée dans l'épaisseur du panneau de la porte (56) et fixée au panneau de la porte (56) d'une telle façon que son axe est perpendiculaire à ce dernier (56);
 - un arbre central (20) inséré de manière coaxiale et rotative dans la bague (12); l'arbre central (20) est à même de tourner autour de l'axe de la bague (12) aussi bien que de se déplacer le long dudit axe; où des moyens (26, 24; 27, 24) sont prévus pour guider le mouvement et la rotation de l'arbre central (20), lui permettant de tourner dans la direction compatible avec la direction d'ouverture de la porte; où les moyens de guidage pour l'arbre central (20) comprennent deux guides opposés (26; 27) prévues dans la paroi intérieure de la bague (12) et des

- cliquets (24) correspondants saillant radialement de l'arbre central (20) et coopérant avec les guides (26; 27), ces dernières (26; 27) ayant une inclination par rapport à l'axe de la bague (12) qui est compatible avec la direction d'ouverture de la porte; où un ressort hélicoïdal préchargé (28) repose avec une extrémité sur un collier (30) de l'arbre central (20), alors que l'autre extrémité repose contre une marche (32) à l'intérieur de la bague (12); et où
- des moyens extérieurs (44), par exemple une poignée extérieure, sont prévus pour tourner l'arbre central (20);
 - des moyens intérieurs (46), par exemple une poignée intérieure, sont prévus pour tourner l'arbre central (20), les dites moyens intérieurs étant pourvus d'un percuteur (54) adapté à entrer en contact avec un point fixe, par exemple un montant de l'encadrement de la porte, de façon à ce que, suite à la rotation forcée, achevée par lesdits moyens extérieurs (44) ou moyens intérieurs (46), de l'arbre central (20) dans la direction compatible avec la direction d'ouverture de la porte, un conséquent appui forcé dudit percuteur (54) contre ledit point fixe soit achevé, de façon à dégager la porte; **caractérisé en ce que** la bague (12) a une longueur inférieure à l'épaisseur de la totalité ou au moins d'une partie des panneaux (56) de cette porte, un bouchon à anneau (14) étant prévu pour se connecter coaxialement à la bague (12), de manière que le groupe bague (12) - bouchon à anneau (14) ait une longueur adaptée à l'épaisseur du panneau (56) spécifique de la porte, où le couplage entre le bouchon à anneau (14) et la bague (12) est du type "télescopique", des moyens (16) étant prévus pour fixer le bouchon à anneau (14) à la bague (12) pour obtenir la longueur nécessaire du groupe bague (12) - bouchon à anneau (14).
2. Dispositif selon la revendication 1, où dans une seule et même bague (12) des premiers moyens de guidage (26, 24) pour l'arbre central (20), lui permettant de tourner dans la direction correspondante à celle d'une porte ayant une direction d'ouverture déterminée, aussi bien que des seconds moyens de guidage (27, 24) permettant à l'arbre central (20) de tourner dans la direction opposée correspondante à la direction d'ouverture d'une porte ayant une direction d'ouverture opposée, sont prévus.
 3. Dispositif selon la revendication 2, où les premiers et les seconds moyens de guidage pour l'arbre central (20) comprennent respectivement deux premières guides (26) et deux secondes guides (27) pourvues dans la paroi intérieure de la bague (12), la position angulaire des deux secondes guides (27) étant tournée jusqu'à 90° par rapport à celle des deux premières guides (26).
 4. Dispositif selon la revendication 3, où les guides (26; 27) ont une butée de fin de course fixe (34; 35) correspondante à la position angulaire de l'arbre central (20) par rapport au panneau (56) de la porte, l'autre butée de fin de course (36) étant amovible et positionnable, selon la direction d'ouverture de la porte à droite ou à gauche, pour agir en tant que butée de fin de course pour les moyes de guidage (27, 24) de l'ouverture à droite ou pour les moyens de guidage (26, 24) de l'ouverture à gauche, respectivement.
 5. Dispositif selon la revendication 1, où les moyes extérieurs et les moyens intérieurs pour tourner l'arbre central (20) comprennent des leviers actionnables manuellement (44, 46).
 6. Dispositif selon la revendication 5, où le levier intérieur (46) est pivoté à un point intermédiaire du même et fixé en correspondance de ce point à l'arbre central (20), l'extrémité du levier intérieur (46) opposée à l'extrémité de préhension présentant un percuteur (54) ayant la forme d'une tête de marteau destiné à entrer en contact avec le point fixe, sur l'un ou l'autre côté, selon la direction d'ouverture de la porte.

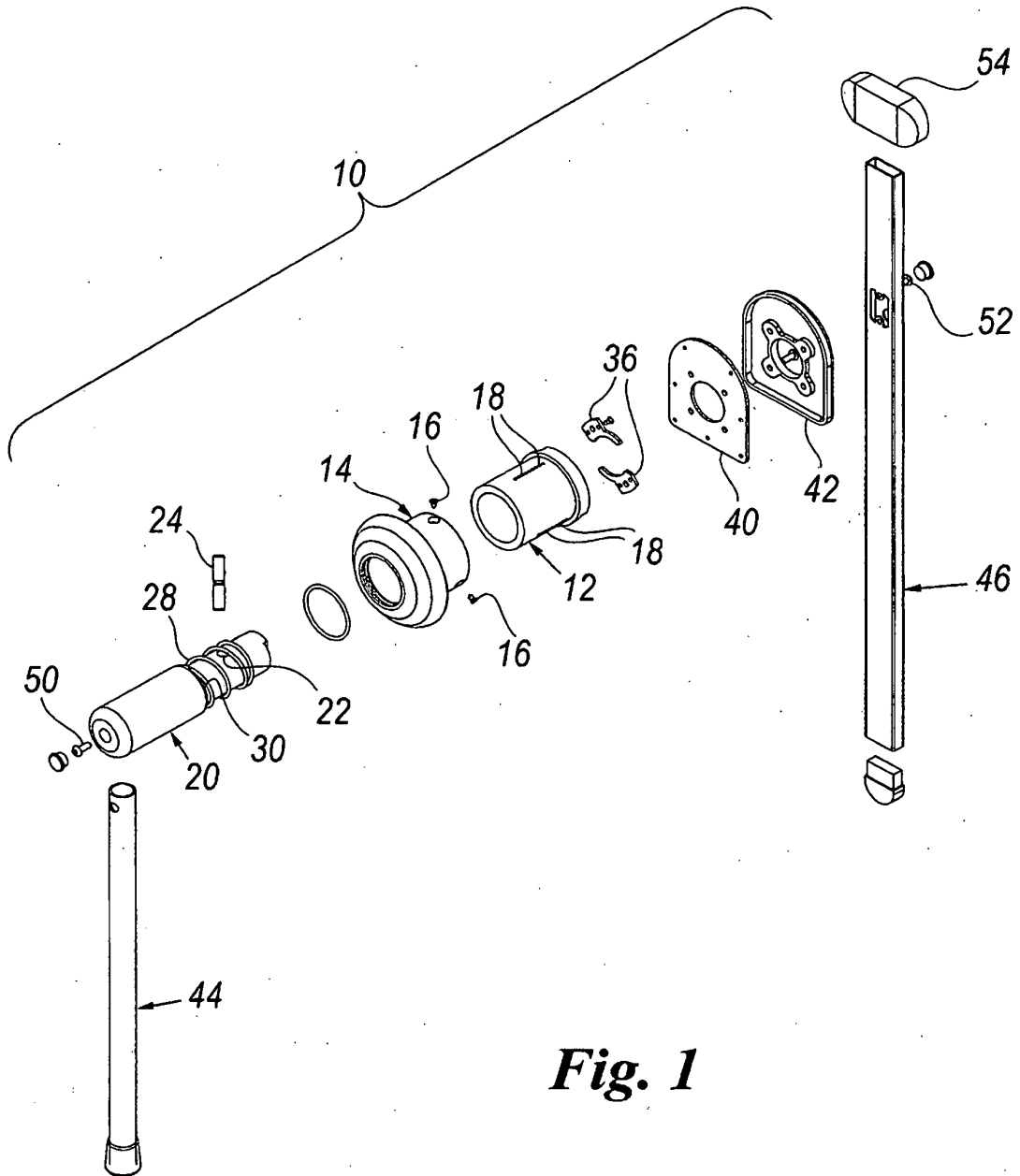

Fig. 1

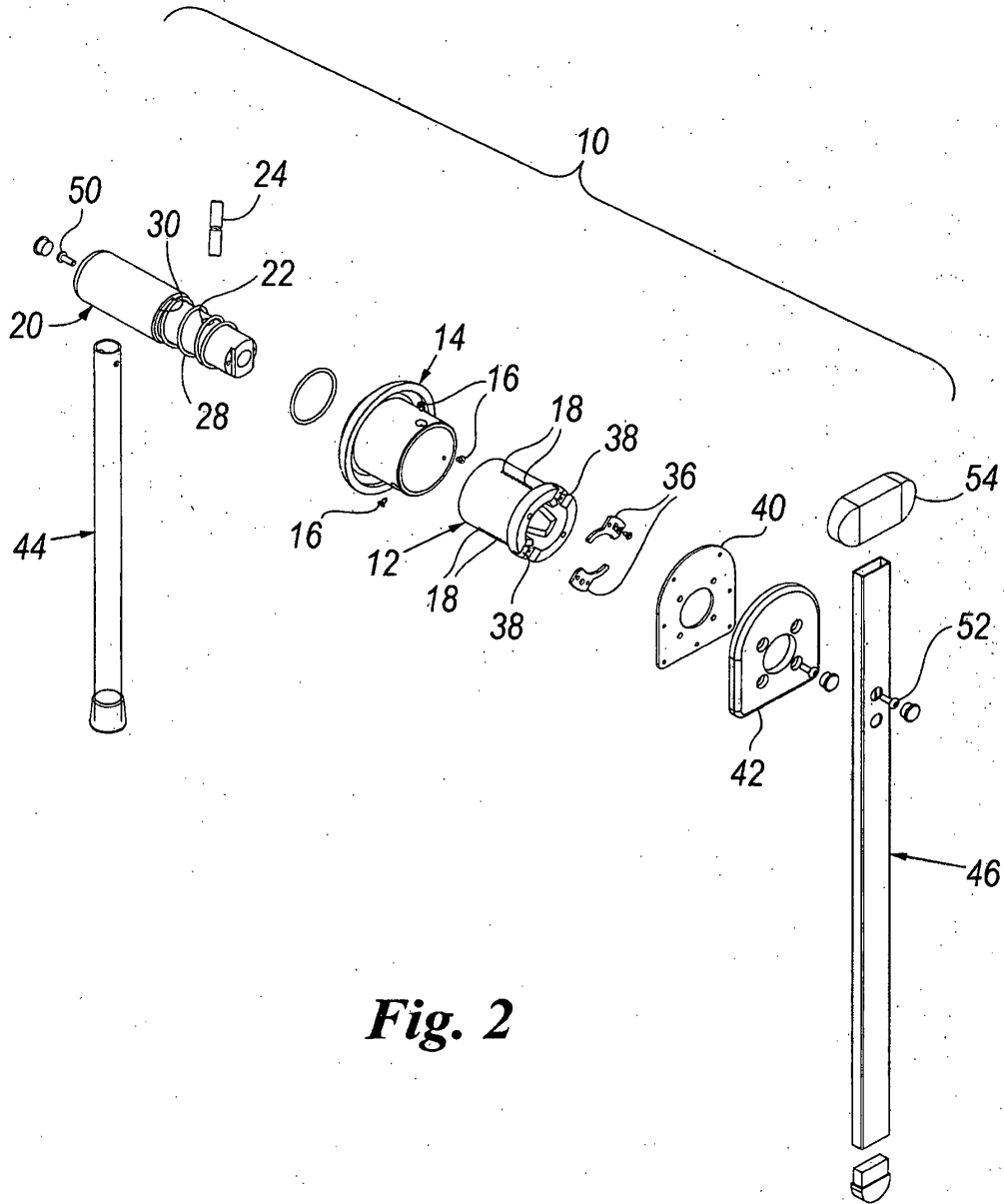

Fig. 2

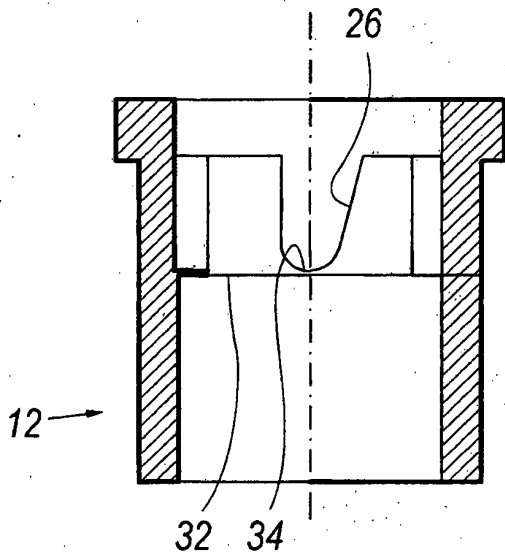
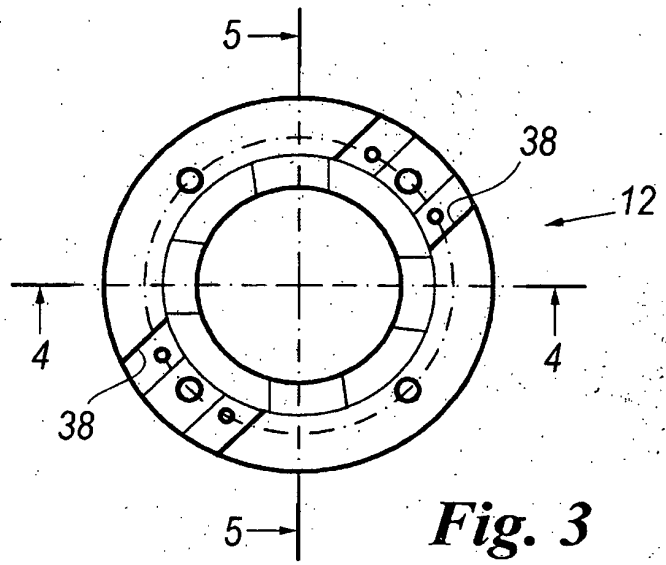

Fig. 4

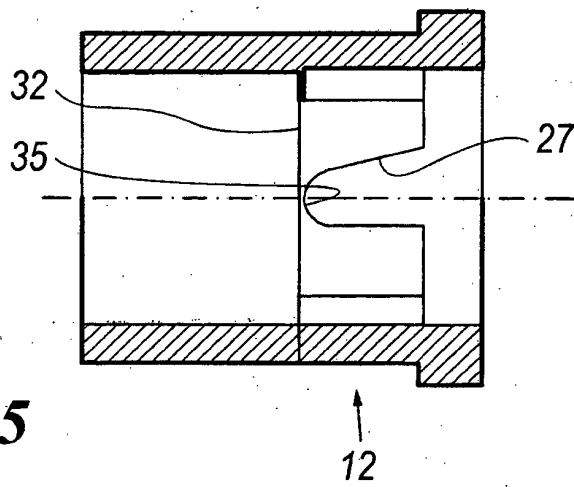

Fig. 5

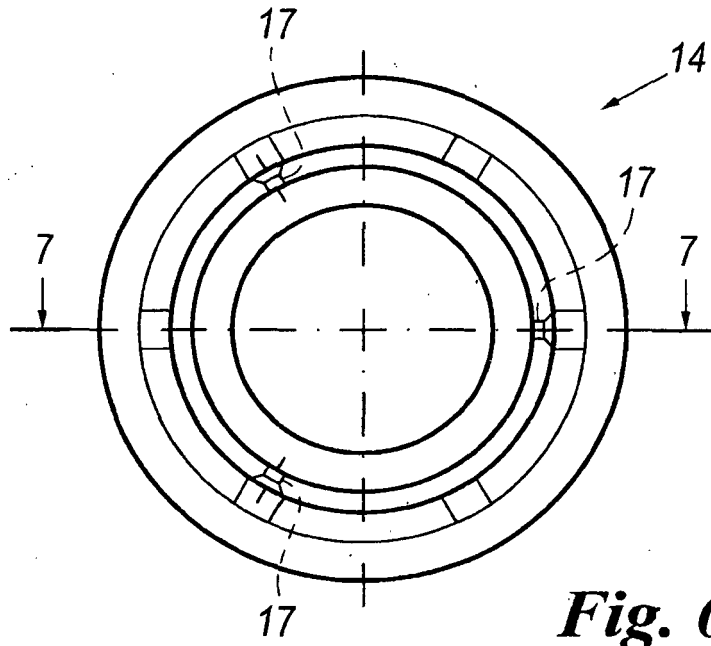

Fig. 6

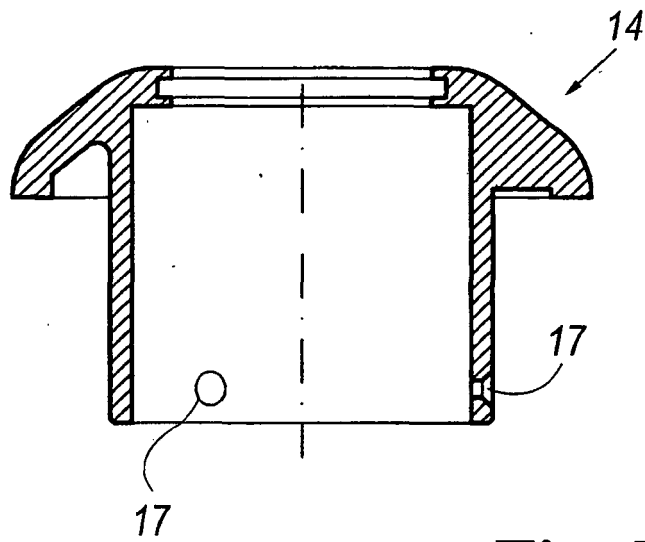

Fig. 7

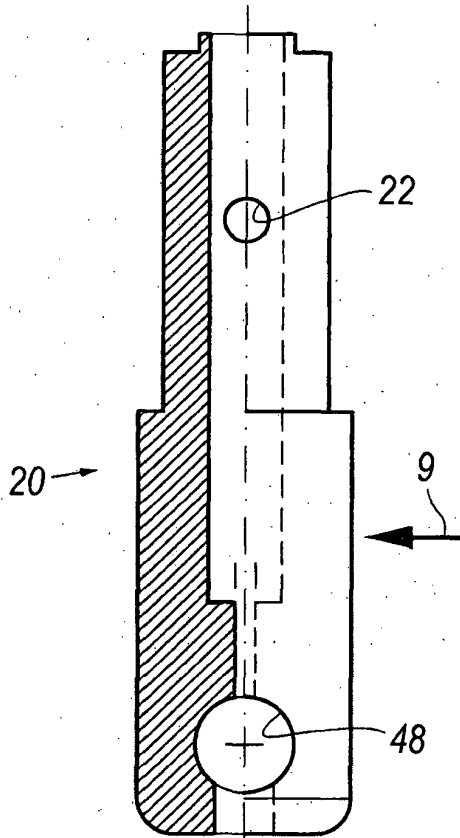

Fig. 8

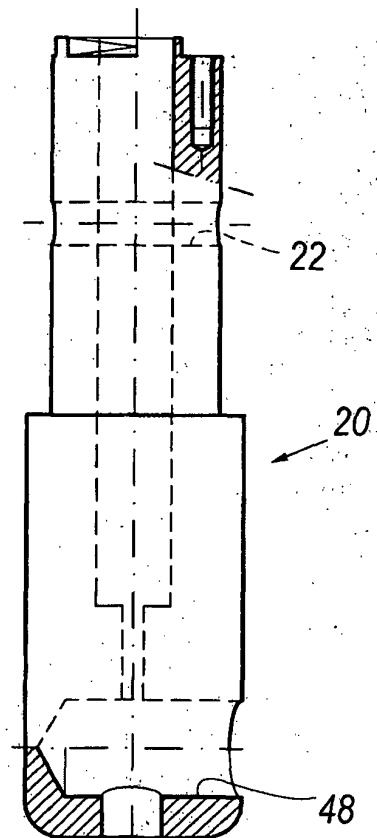

Fig. 9

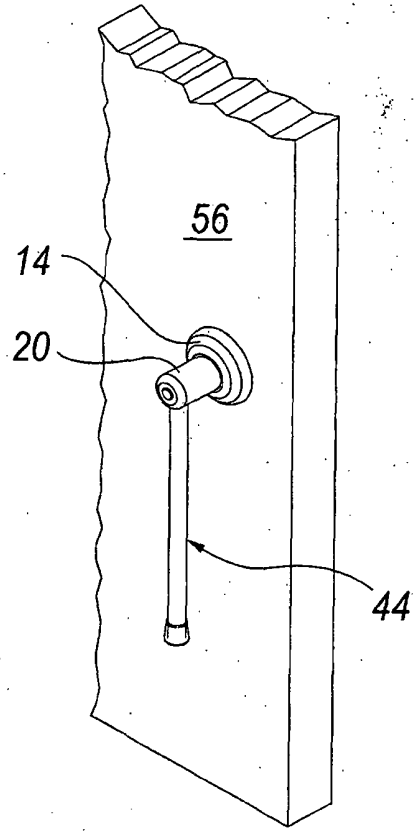

Fig. 10

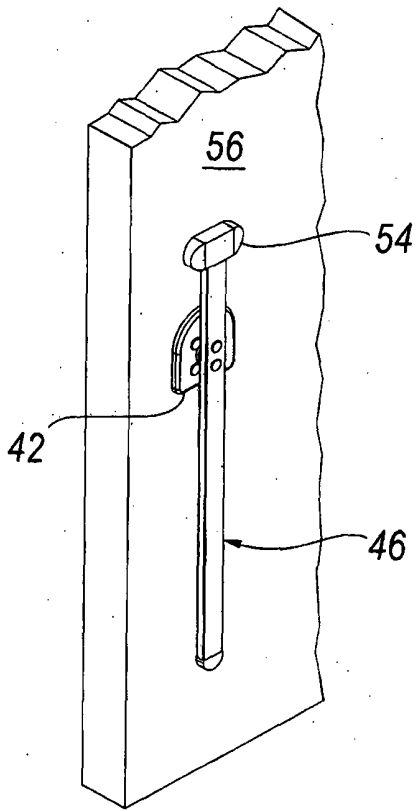

Fig. 11

REFERENCES CITED IN THE DESCRIPTION

This list of references cited by the applicant is for the reader's convenience only. It does not form part of the European patent document. Even though great care has been taken in compiling the references, errors or omissions cannot be excluded and the EPO disclaims all liability in this regard.

Patent documents cited in the description

- DE 2758521 [0008]