

(19)



(11)

EP 2 443 961 A1

(12)

EUROPEAN PATENT APPLICATION

(43) Date of publication:
25.04.2012 Bulletin 2012/17

(51) Int Cl.:
A46B 13/00^(2006.01) A46D 1/00^(2006.01)
E01H 1/05^(2006.01)

(21) Application number: **11001058.4**

(22) Date of filing: **09.02.2011**

(84) Designated Contracting States:
AL AT BE BG CH CY CZ DE DK EE ES FI FR GB GR HR HU IE IS IT LI LT LU LV MC MK MT NL NO PL PT RO RS SE SI SK SM TR
Designated Extension States:
BA ME

(72) Inventor: **Rae-Kwon, Kim**
Songpa-Gu
Seoul (KR)

(30) Priority: **22.10.2010 KR 20100103487**

(74) Representative: **Müller-Boré & Partner**
Patentanwälte
Grafinger Straße 2
81671 München (DE)

(71) Applicant: **Sambo Heavy Industries Co., Ltd.**
Danwon-gu
Ansan-si, Gyeonggi-do (KR)

(54) **Broom brush for a cleaning vehicle**

(57) A broom brush for a cleaning vehicle is disclosed, which has an excellent elastic recovery force and an enhances anti-wearing performance while preventing the neighboring brushing members from being entangled for thereby extending a life span of a product and reducing a maintenance cost. The broom brush for a cleaning

vehicle comprises a plurality of brushing members which are engaged at a front side of a cleaning vehicle for cleaning a certain area with the aid of a rotation operation, said brushing members comprising cores made of metallic wires each having a certain elastic force. The metallic wires have plastic coating layers coated on the outer sides of the cores.

Fig. 1

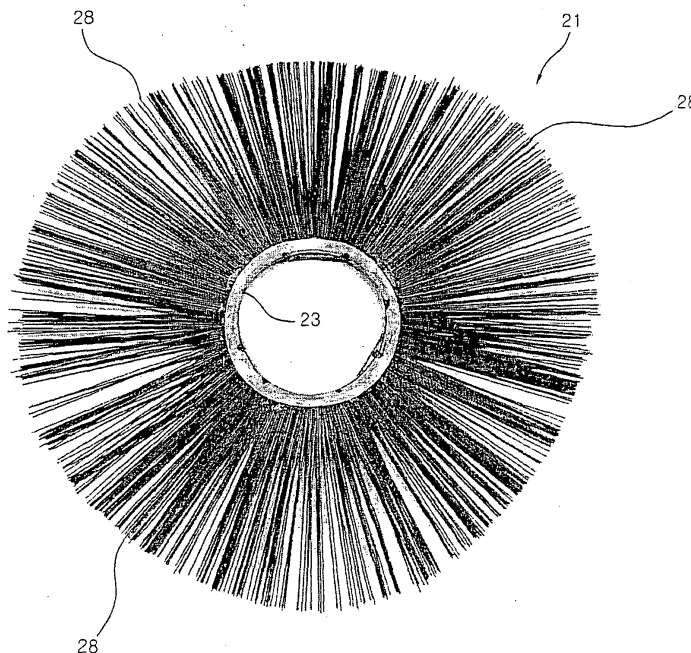

EP 2 443 961 A1

Description

TECHNICAL FIELD

[0001] The present invention relates to a broom brush for a cleaning vehicle, and a broom brush for a cleaning vehicle which is used to clean a certain area such as a road construction site or a building construction site where lots of dusts or wastes to be cleaned are produced.

BACKGROUND ART

[0002] As shown in Figure 10 and 11 a cleaning tool, called a broom brush 11, is fixed at a rotary shaft in a row in a front side of a cleaning vehicle 10 for cleaning a place such as a road construction site, a building construction site, a golf field and an artificial lawn field where a lot of wastes to be cleaned are produced. As the cleaning vehicle 10 moves forward and backward, the broom brush 11 is rotated by means of a hydraulic motor for thereby cleaning wastes.

[0003] As shown in Figure 11, the broom brush 11 used for cleaning a wide area place is equipped with an engaging hole 12 for inserting at a rotary shaft, and the roots of brushing members 14 are inserted into a U-shaped groove of a metal ring 13 having a U-shaped cross section, with the brushing members being arranged in a radial direction, and an adhesive is inserted into the U-shaped groove, and both side walls are compressed and bent in a S-shape. So, as the broom brush 11 engaged at the rotary shaft rotates, the brushing members 14 arranged in a radial shape perform a cleaning work while brushing like a broom and cleaning wastes.

[0004] The brushing members 14 are made of materials with excellent elastic forces because it is needed for the brushing member to be bent like a bow and then to be elastically recovered in the course of cleaning, with the brushing members being formed like a longitudinal and thin rod member and contracting with the ground. So, the brushing members 14 are preferably made of a high elastic plastic material, which is one of special materials, and are molded with a certain diameter and length.

[0005] When the high elastic brushing members 14 made of special plastic materials are used for cleaning an asphalt road of which the surface is cut off for a reconstruction of the paved road, the brushing members 14 might be easily worn out due to rough cleaning environment, which results in a more frequent replacement of the broom brush 11 for thereby disadvantageously increasing a maintenance cost.

[0006] There was a trial that a brushing member is made of an excellent elastic metallic wire having a much better anti-wearing performance than a plastic material in order to overcome the above conventional problems. When an elastic metallic wire is used, an elastic recovery force can be enhanced, and an anti-wearing performance can be also enhanced for thereby extending the life span

of the product, but neighboring elastic metallic wires get entangled, which leads to worsening a cleaning efficiency, so that it has not been actually applied in the industry.

5 DISCLOSURE OF THE INVENTION

[0007] Accordingly, it is an object of the present invention to provide a broom brush for a cleaning brush and a method for manufacturing the same which can provide an excellent elastic recovery force while preventing neighboring brushing wires from getting entangled and enhancing an anti-wearing performance for thereby significantly reducing a maintenance cost along with an increased life span of a product.

10 **[0008]** To achieve the above objects, there is provided a broom brush for a cleaning vehicle, comprising a plurality of brushing members which are engaged at a front side of a cleaning vehicle for cleaning a certain area with the aid of a rotation operation, the brushing members comprising cores made of metallic wires each having a certain elastic force; and plastic coated metallic wires formed of plastic coating layers coated on the outer sides of the cores.

15 **[0009]** The plastic coated metallic wires are installed at a front side of a cleaning vehicle, with the roots of the plastic coated metallic wires being accommodated into a U-shaped groove of a fixing member having a U-shaped cross section which is fixedly engaged at a rotary shaft rotating by means of a driving member, with the plastic coated metallic wires being arranged in a radial shape, with the plastic coated metallic wires being gathered and fixed by compressing both the side walls of the fixing member.

20 **[0010]** The plastic coated metallic wires are folded in a V-shape and are inserted into the fixing metallic wires and are gathered and arranged in one line, and then the fixing metallic wires are fixedly wound onto an outer surface of a cylindrical portion of the fixing member in a ring shape, and the plastic coated metallic wires are exploded in a radial shape, and the plastic coated metallic wires are compressed and fixed by compressing both the side walls of the fixing member.

25 **[0011]** The fixing member is formed by engaging a pair of members of which the ends are formed in L-shapes.

30 **[0012]** The side walls of the fixing member are compressed and form an S-shaped bent portion.

35 **[0013]** The core is made of a material selected from the group comprising a piano steel wire, a light steel wire, a high carbon steel and spring steel.

40 EFFECTS

45 **[0014]** According to the present invention, the metallic cores having better elastic forces are positioned in the center of the brushing members of the broom brush for a cleaning vehicle, and the outer construction of the metallic core is surrounded with a plastic coating layer. The plastic coating layer having an excellent elastic recovery

force for allowing the brushing members to elastically bend and recover in the course of cleaning and having a smooth and slippery surface property is used for thereby preventing the brushing members from being entangled, which leads to extending the life span of a product and decreasing a maintenance cost. In particular, a metallic core can be folded in a V-shape and is linked with a steel wire in a ring shape and is engaged, so that the metallic core is not disengaged, and an adhesive is not advantageously used for preventing the brushing members from being disengaged.

BRIEF DESCRIPTION OF THE DRAWINGS

[0015] The present invention will become better understood with reference to the accompanying drawings which are given only by way of illustration and thus are not limitative of the present invention, wherein;

Figure 1 is a photo of one side of a broom brush for a cleaning vehicle according to the present invention;

Figure 2 is a view illustrating a cross section of a broom brush for a cleaning vehicle according to the present invention;

Figure 3 is a photo of a front side of an outer appearance of a broom brush for a cleaning brush according to the present invention;

Figure 4 is a front cross sectional view illustrating a brushing member of broom brush for a cleaning vehicle according to the present invention;

Figure 5 is a side cross sectional view illustrating a brushing member of a broom brush for a cleaning vehicle according to the present invention;

Figure 6 is a view illustrating a construction that a brushing member is folded in a V shape and is hung over a metallic wire according to the present invention;

Figure 7 is a side cross sectional view illustrating a state that a brushing member is folded in a V shape and is hung over a metallic wire and is wound at a cylindrical portion of a fixing member in a ring shape according to the present invention;

Figure 8 is a view illustrating a fixing member according to another example of the present invention;

Figure 9 is a front cross sectional view illustrating a state that a V-shaped brushing member is wound and attached at a fixing member of Figure 8 in a ring shape before a side wall is compressed according to the present invention; and

Figures 10 and 11 are views for describing the conventional art.

MODES FOR CARRYING OUT THE INVENTION

[0016] The preferred embodiments of the present invention will be described with reference to the accompanying drawings.

[0017] As shown in Figures 1 and 2, the broom brush

21 according to the present invention is engaged at a rotary shaft driven by a certain driving member, for example, an electric motor or an engine, a preferably a hydraulic motor, in a front side of a cleaning vehicle 10 for thereby cleaning on the ground. The broom brush 21 comprises a fixing member 23 having an engaging hole 22 at its center portion, and the cross section of the fixing member 22 is formed in a U shape of which an outer side is open by means of a cylindrical portion 24 inserted into the rotary shaft and the side walls 25 and 26 vertically extended from both the ends of the cylindrical portion 24, with the ends of the brushing members 24 being inserted into the U shaped groove 27 via the opening, and both the side walls 25 and 26 of the fixing member 23 are compressed for thereby fixing the roots of the brush members 26 with the aid of both the side walls 25 and 26 of the fixing member 23. In this state, the brushing members 28 look a radial shape like a hand fan, and an adhesive (indicated as a dot in the groove 27 of Figure 2) is filled in the U shaped groove 27 so as to prevent the brushing members 28 from being disengaged, and the side walls 25 and 26 are preferably compressed.

[0018] As shown in Figures 4 and 5, the brushing member 28, which is one of the key elements of the present invention, comprises a plastic coated metallic wire 28 which is formed of a core 29 made of a metallic wire having an elastic force as seen in its cross section and a plastic coating layer 30 coated on an outer side of the core. The brushing member, namely, plastic coated metallic wire 28 is formed in a dual material structure.

[0019] The core 29 is made of an elastic metallic wire, for example, a piano wire having an excellent elastic force which is bent and then recovered or a light steel wire or a carbon steel or a spring steel which are all a special steel having an excellent elastic force.

[0020] In a state that the plastic coated metallic wires 28 are engaged, when the fixing member 23 is compressed, it is pressed that both the side walls 25 and 26 are not flat but are formed in as S-shaped protrusion shape on its surface. Figure 3 is a photo taken from its front side of a broom brush 21 according to the present invention, in which the fixing member 23 is bent in an S shape. In this bent state, it is advantageous that one broom brush 21 can cover a wide cleaning range B when a plurality of broom brushes 21 are inserted in a row on the rotary shaft.

[0021] Figures 6 to 9 are views illustrating an example that the plastic coated metallic wire 28 is engaged according to the present invention. As shown in Figure 2, when the plastic coated metallic wire 28 is formed in a straight line shape and then is fixed, it is possible to prevent the metallic core 29 from being disengaged. In case of the plastic coated metallic wire 28, the core 29 and the plastic coating layer 30 have a weak engaging force due to the difference in their physical properties, so the boundary between them is actually separated, whereby the core 27 might be disengaged.

[0022] In order to prevent the above problems, the

plastic coated metallic wires 28 according to the present invention are bent in a V shape as shown in Figure 6, and the V-shaped plastic coated metallic wires 28a (here, reference number 28a means that the plastic coated metallic wires are bent in a V shape) are intensively hung over the fixing metallic wire 31 in a row, and, as shown in Figure 7, are wound on the outer surface of the cylindrical portion 24 of the fixing member 23 in a ring shape. At this time, the ring structure 32 is wound to form one line or two through five lines.

[0023] In this state, the broom brush 21 is made by compressing both the side walls 25 and 26 (for making the surface protruded as shown in Figure 3) and fixing the ring shaped structure 32 which contains the V-shaped plastic coated metallic wires 28a.

[0024] Figure 8 is a view illustrating another example of the fixing member. The fixing member 23 comprises the cylindrical portions 24a and 24b inserted and engaged with each others, and L-shaped left and right members 33 and 34 having side walls 25 and 26. The ring shaped structure 32 is previously manufactured. At least one ring shaped structure 32 is inserted into an outer side of the cylindrical portion 24a of the one side member 33 as shown in Figure 9, and the cylindrical portion 24b of the other side member 34 is inserted into the cylindrical portion 24a, and a force F is applied from both sides, so that the cylindrical portions 24a and 24b engaged with each other are bent for thereby strongly and easily fixing the ring shaped structure 32. As an advantage of the embodiment of the present invention, the left and right members 33 and 34 can be easily manufactured by means of a press molding process, and the workability for engaging the ring shaped structure 32 is excellent, which is most preferred as a result of the tests conducted by the inventor.

[0025] The brushing members 28 according to the present invention, namely, the plastic coated metallic wires 28, are made in such a manner that the cores 29 with high elastic forces are inserted into the center portions of the same, with the cores being bent in the course of cleaning and then recovered in a straight ling shape. The brushing members 28 have excellent anti-wearing properties as compared to when only plastic material is used, and can be used for a long time, which results in preventing a frequent exchange of the same and decreasing a maintenance cost. In particular, since the plastic coated metallic wires 28 are engaged in a V shape, the cores 29 are not disengaged. A stable engaging state can be obtained without using an adhesive. Since the fixing member is divided into two parts, an assembling performance can be significantly enhanced.

[0026] Here, reference number 35 represents an insertion hole of a rivet 15 (refer to Figure 10) for being fixed to the rotary shaft, and reference number 36 represents an open groove formed to surround the outer side of the rivet 15 when it is engaged to the other side member 33.

[0027] The brushing member according to the present

invention has been described as it is engaged to the fixing member and is used. In another example of the present invention, the brushing members might be engaged to a lower surface of a circular plate which rotates on a plane surface by means of a motor for thereby efficiently performing a cleaning work, which is not out of the scope of the present invention.

[0028] As the present invention may be embodied in several forms without departing from the spirit or essential characteristics thereof, it should also be understood that the above-described examples are not limited by any of the details of the foregoing description, unless otherwise specified, but rather should be construed broadly within its spirit and scope as defined in the appended claims, and therefore all changes and modifications that fall within the meets and bounds of the claims, or equivalences of such meets and bounds are therefore intended to be embraced by the appended claims.

Claims

1. A broom brush for a cleaning vehicle, comprising a plurality of brushing members which are engaged at a front side of a cleaning vehicle for cleaning a certain area with the aid of a rotation operation, said brushing members comprising cores made of metallic wires each having a certain elastic force; and plastic coated metallic wires formed of plastic coating layers coated on the outer sides of the cores.
2. A broom brush for a cleaning vehicle according to claim 1, wherein said plastic coated metallic wires are installed at a front side of a cleaning vehicle, with the roots of the plastic coated metallic wires being accommodated into a U-shaped groove of a fixing member having a U-shaped cross section which is fixedly engaged at a rotary shaft rotating by means of a driving means, with the plastic coated metallic wires being arranged in a radial shape, with the plastic coated metallic wires being gathered and fixed by compressing both the side walls of the fixing member.
3. A broom brush for a cleaning vehicle according to claim 1 or 2, wherein said plastic coated metallic wires are folded in a V-shape and are inserted into the fixing metallic wires and are gathered and arranged in one line, and then the fixing metallic wires are fixedly wound onto an outer surface of a cylindrical portion of the fixing member in a ring shape, and the plastic coated metallic wires are exploded in a radial shape, and the plastic coated metallic wires are compressed and fixed by compressing both the side walls of the fixing member.
4. A broom brush for a cleaning vehicle according to anyone of claims 1 to 3 wherein said fixing member

is formed by engaging a pair of members of which the ends are formed in L-shapes.

5. A broom brush for a cleaning vehicle according to anyone of claims 2 through 4, wherein said both the side walls of the fixing member are compressed and form an S-shaped bent portion. 5
6. A broom brush for a cleaning vehicle according to anyone of claims 1 through 5, wherein said core is made of a material selected from the group comprising a piano steel wire, a light steel wire, a high carbon steel and spring steel. 10

15

20

25

30

35

40

45

50

55

Fig. 1

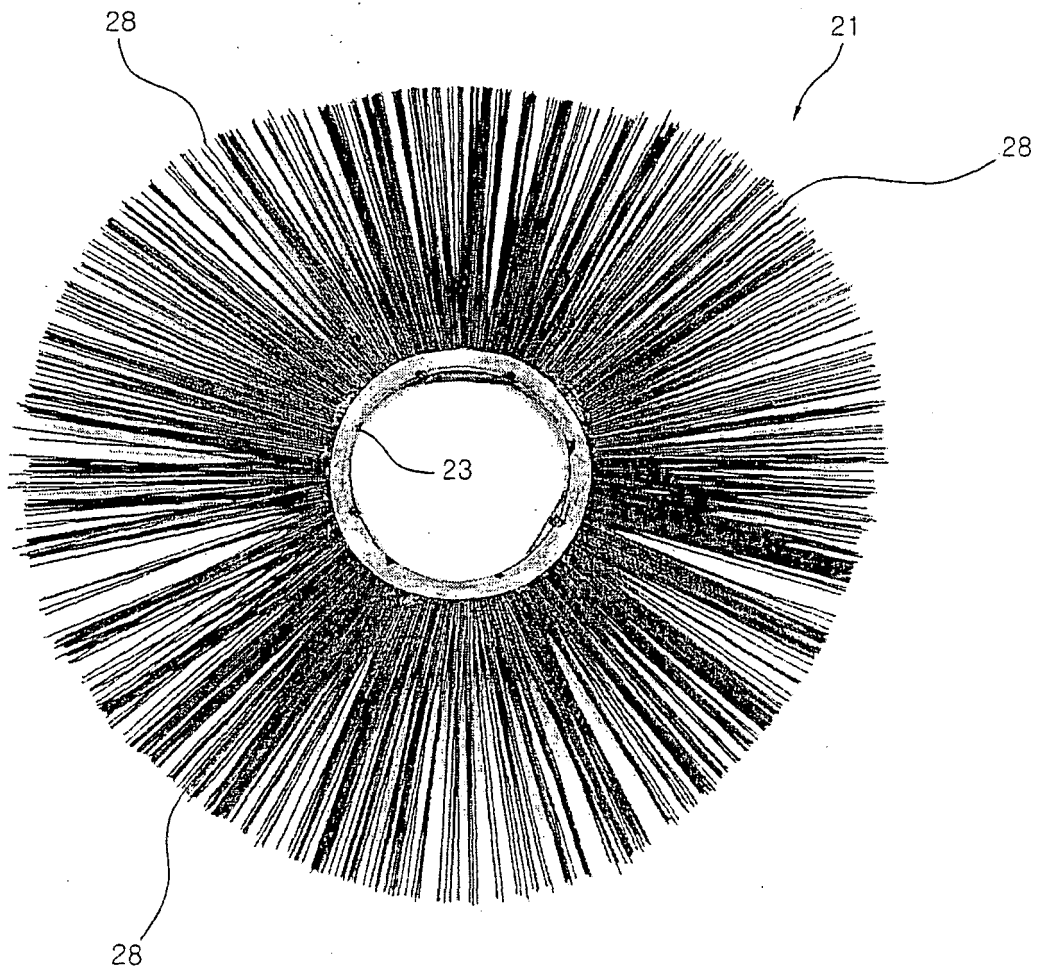

Fig. 2

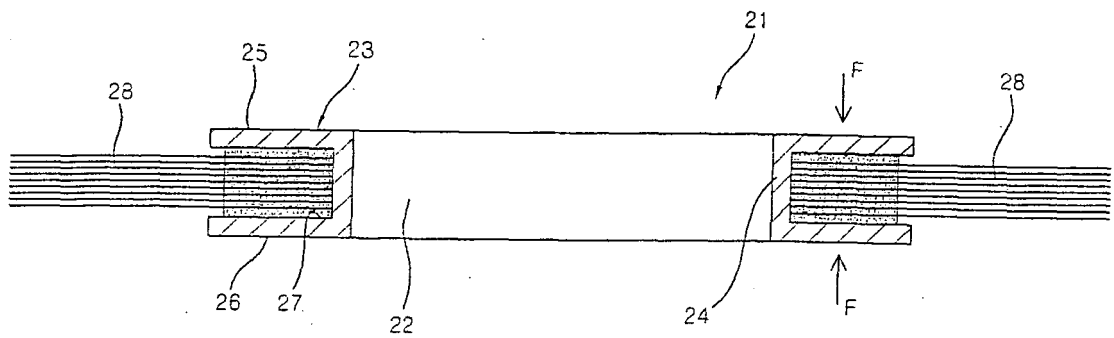

Fig. 3

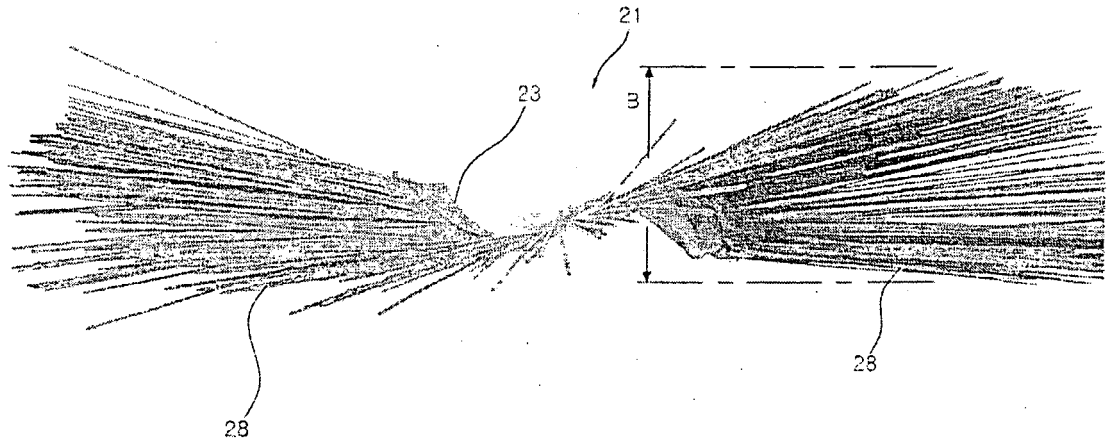

Fig. 4

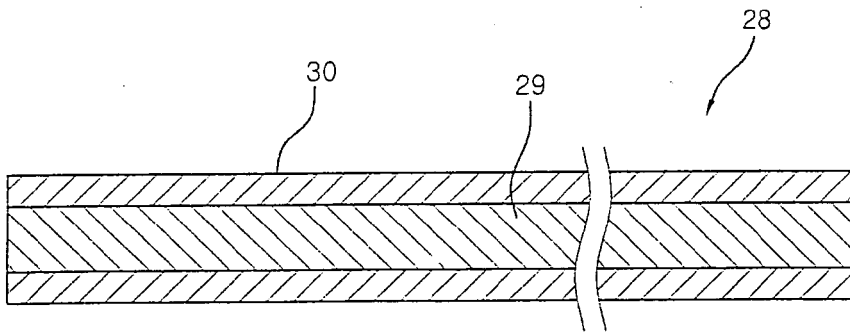

Fig. 5

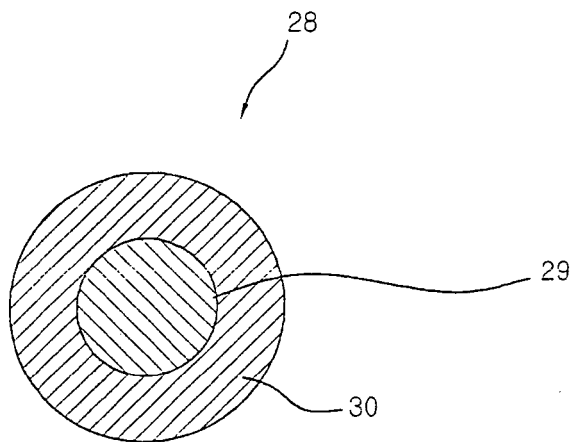

Fig. 6

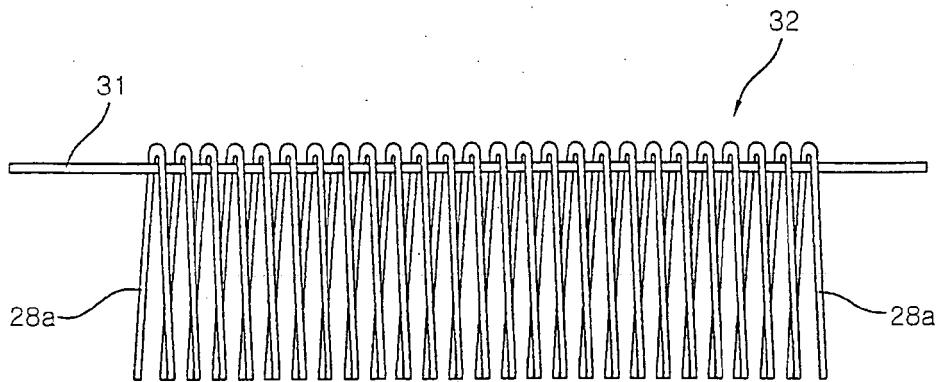

Fig. 7

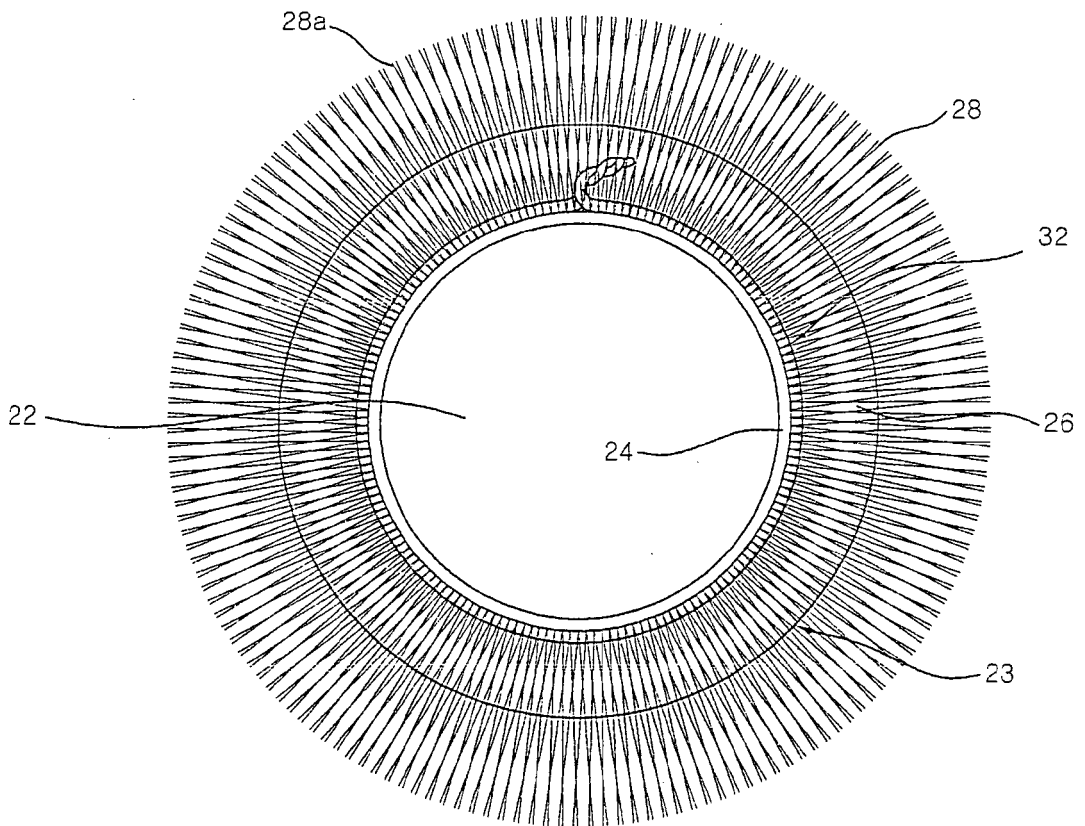

Fig. 8

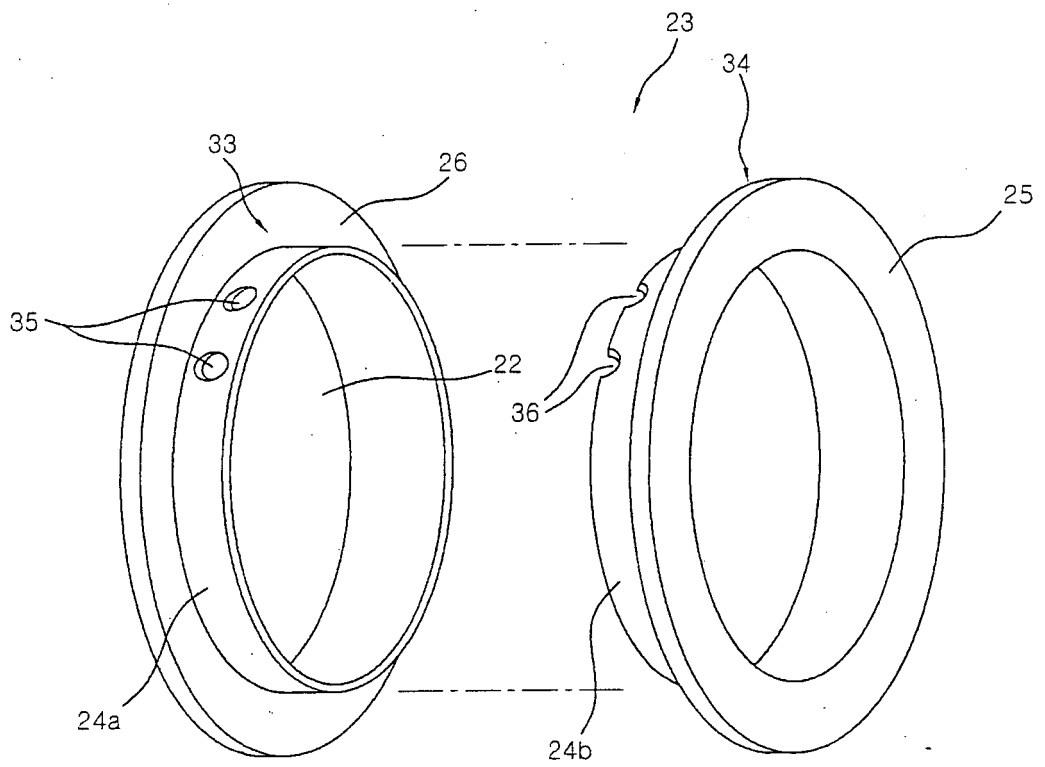

Fig. 9

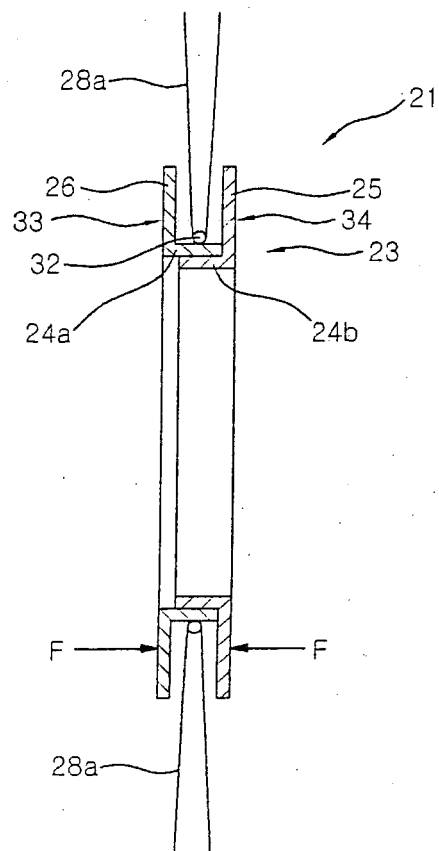

Fig. 10

PRIOR ART



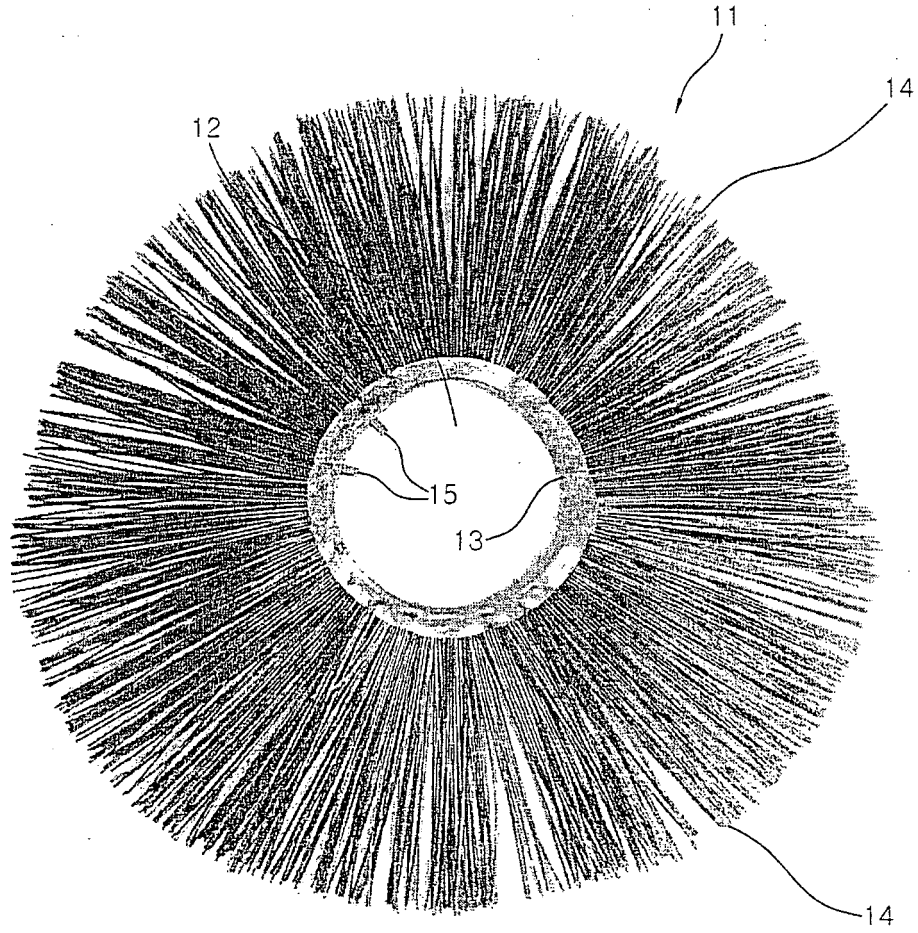

Fig. 11



EUROPEAN SEARCH REPORT

Application Number
EP 11 00 1058

| DOCUMENTS CONSIDERED TO BE RELEVANT | | | |
|--|---|--|---|
| Category | Citation of document with indication, where appropriate, of relevant passages | Relevant to claim | CLASSIFICATION OF THE APPLICATION (IPC) |
| X | US 5 249 332 A (WILKERSON KENNETH R [US]) 5 October 1993 (1993-10-05) | 1 | INV. A46B13/00 A46D1/00 E01H1/05 |
| Y | * column 3, line 60 - column 7, line 24; figures 1-5 * | 2-6 | |
| X | WO 2010/024670 A1 (JORISSEN CLEMENS JOHANNES FRANCISCUS MARIA [NL]) 4 March 2010 (2010-03-04) | 1 | |
| A | * page 7, line 26 - page 9, line 23; figures 1-7 * | 2-5 | |
| Y | GB 962 502 A (NAT AIRCRAFT CORP) 1 July 1964 (1964-07-01) | 2,3,5,6 | |
| Y | US 2 682 734 A (PETERSON RUBEN O) 6 July 1954 (1954-07-06) | 2,3,6 | |
| Y | * column 3, line 8 - column 6, line 48; figures 1-7 * | | |
| Y | DE 297 10 671 U1 (LIPPERT H GMBH [DE]) 4 September 1997 (1997-09-04) | 4 | TECHNICAL FIELDS SEARCHED (IPC) |
| | * page 7, line 32 - page 8, line 15; figure 4 * | | A46B A46D E01H |
| Y | DE 19 69 618 U (KULLENBUERSTEN KULLEN & CO K G [DE]) 5 October 1967 (1967-10-05) | 4 | |
| | * page 4, line 12 - page 5, line 18; figures 1,2 * | | |
| The present search report has been drawn up for all claims | | | |
| Place of search Munich | | Date of completion of the search 29 April 2011 | Examiner Kunz, Lukas |
| CATEGORY OF CITED DOCUMENTS X : particularly relevant if taken alone Y : particularly relevant if combined with another document of the same category A : technological background O : non-written disclosure P : intermediate document | | T : theory or principle underlying the invention E : earlier patent document, but published on, or after the filing date D : document cited in the application L : document cited for other reasons & : member of the same patent family, corresponding document | |

1
EPO FORM 1503 03.02 (P04C01)

**ANNEX TO THE EUROPEAN SEARCH REPORT
ON EUROPEAN PATENT APPLICATION NO.**

EP 11 00 1058

This annex lists the patent family members relating to the patent documents cited in the above-mentioned European search report. The members are as contained in the European Patent Office EDP file on
The European Patent Office is in no way liable for these particulars which are merely given for the purpose of information.

29-04-2011

| Patent document cited in search report | | Publication date | Patent family member(s) | Publication date |
|--|----|------------------|------------------------------|--------------------------|
| US 5249332 | A | 05-10-1993 | NONE | |
| WO 2010024670 | A1 | 04-03-2010 | NL 1035872 C NL 2004259 C | 16-03-2010 02-11-2010 |
| GB 962502 | A | 01-07-1964 | NONE | |
| US 2682734 | A | 06-07-1954 | NONE | |
| DE 29710671 | U1 | 04-09-1997 | NONE | |
| DE 1969618 | U | 05-10-1967 | NONE | |