



(11) **EP 2 447 974 A1**

(12) **EUROPEAN PATENT APPLICATION**
published in accordance with Art. 153(4) EPC

(43) Date of publication:
02.05.2012 Bulletin 2012/18

(51) Int Cl.:
H01H 21/00 (2006.01) H01H 25/00 (2006.01)

(21) Application number: **10799495.6**

(86) International application number:
PCT/IB2010/001491

(22) Date of filing: **21.06.2010**

(87) International publication number:
WO 2011/007221 (20.01.2011 Gazette 2011/03)

(84) Designated Contracting States:
AL AT BE BG CH CY CZ DE DK EE ES FI FR GB GR HR HU IE IS IT LI LT LU LV MC MK MT NL NO PL PT RO SE SI SK SM TR

(72) Inventors:
• **NISIKAWA, Akihiro**
Kadoma-shi
Osaka 5718686 (JP)
• **YOKOTA, Hiroshi**
Kadoma-shi
Osaka 5718686 (JP)

(30) Priority: **24.06.2009 JP 2009150281**

(71) Applicant: **Panasonic Corporation**
Osaka 571-8501 (JP)

(74) Representative: **Samson & Partner**
Widenmayerstrasse 5
80538 München (DE)

(54) **BUTTON STRUCTURE FOR ELECTRONIC EQUIPMENT AND FIRE ALARM USING THE BUTTON STRUCTURE**

(57) A push button structure includes a push button 16 having an operating piece 16a, a pressing piece 16b and an elastic support piece 16c. The operating piece 16a has an operating surface 16g, and the pressing piece 16b and the elastic support piece 16c are provided at a first edge 16e of the operating piece 16a. The push button 16 is fitted in a button frame 19 provided in an electronic appliance. The push button 16 is configured such that, when the operating surface 16g is not pushed, a second edge 16f of the operating piece 16a which is opposite to

the first edge 16e is kept spaced apart from an operating piece support portion 19a of the button frame 19 by a resilient force of the elastic support piece 16c and further that, when the operating surface 16g is pushed, the second edge 16f of the operating piece 16c is brought into contact with the operating piece support portion 19a of the button frame 19 against the resilient force of the elastic support piece 16c and then the pressing piece 16b is moved down about the second edge 16f as a fulcrum to activate a switch 12b provided in the electronic appliance.

FIG. 1A

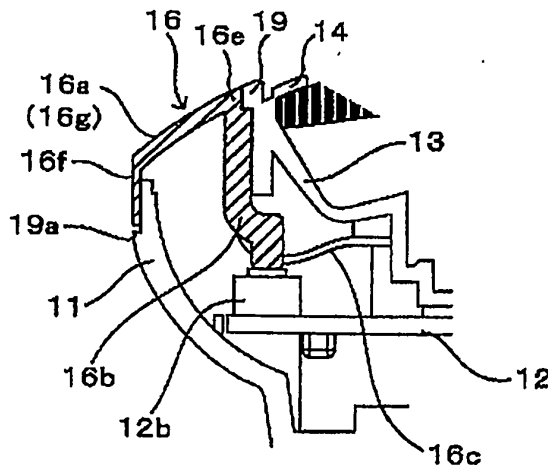

EP 2 447 974 A1

FIG. 1B

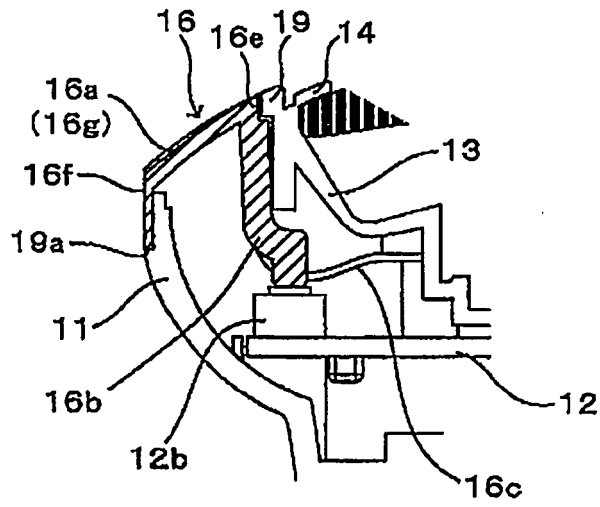
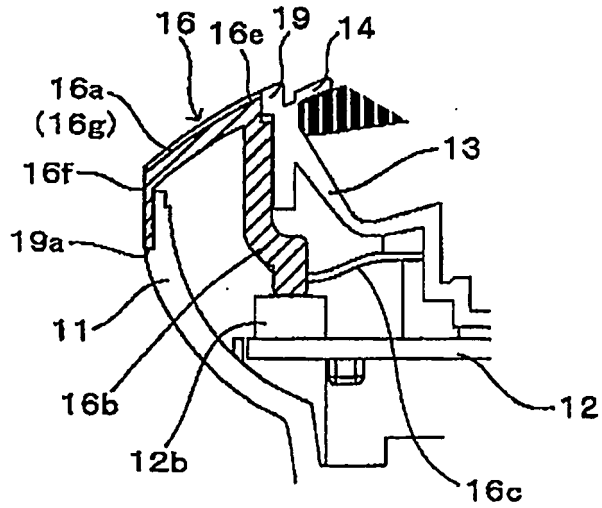

FIG. 1C



Description

Field of the Invention

[0001] The present invention relates to a push button structure provided in an electronic appliance and a fire alarm device using the structure.

Background of the Invention

[0002] Japanese Patent Application Publication No. 2008-171683 discloses a structure of a push button for operating a switch arranged within an electronic appliance. The push button includes a fixing portion attached to a cover, an operating portion and an elastic bridging portion for interconnecting the fixing portion and the operating portion. The bridging portion includes a first bending piece connected at one end to the fixing portion and a substantially U-shaped second bending piece connected at one end to the other end of the first bending piece and at the other end to the operating portion.

[0003] With such configuration, upon pressing the operating portion of the push button, the U-shaped portion of the second bending piece is bent to spread apart, thereby generating a reaction force acting in the opposite direction to the pressing direction. The tendency of the second bending piece to be bent and displaced away from the fixing portion is cancelled as the first bending piece is bent toward the fixing portion. This makes it possible to restrain the operating portion from being displaced in the direction intersecting the pressing direction. Accordingly, it is possible to prevent the side surface of the operating portion from making contact with the inner surface of an exposing hole, eventually impairing the operability and obstructing the movement of the operating portion in the pressing direction. This assists in enhancing the operability of the push button.

[0004] In the afore-mentioned structure, the sense of operation is light because the push button is supported (cantilevered) by only the bending pieces at all times. However, the push button, when pushed, is substantially rotationally moved about the midpoint of a bending axis. This poses a problem in that it is difficult to straightly press and reliably operate a switch provided in a circuit board of an electronic appliance.

Summar of the Invention

[0005] In view of the above, the present invention provides a novel push button structure capable of reliably operating a switch provided in a circuit board of an electronic appliance while improving the sense of operation.

[0006] In accordance with an aspect of the present invention, there is provided a push button structure for an electronic appliance, including a push button including an operating piece, a pressing piece and an elastic support piece, the operating piece having an operating surface, the pressing piece and the elastic support piece

being provided at a first edge of the operating piece, the push button being fitted in a button frame provided in the electronic appliance with the operating surface of the operating piece exposed to the outside, the push button being configured such that, when the operating surface is pushed, the pressing piece is moved down to activate a switch provided in the electronic appliance, **characterized in that:** the button frame has an operating piece support portion; and the push button is configured such that, when the operating surface is not pushed, a second edge of the operating piece which is opposite to the first edge is kept spaced apart from the operating piece support portion of the button frame by a resilient force of the elastic support piece and further that, when the operating surface is pushed, the second edge of the operating piece is brought into contact with the operating piece support portion of the button frame against the resilient force of the elastic support piece and then the pressing piece is moved down about the second edge as a fulcrum to activate the switch.

[0007] The elastic support pieces of the operating piece may be arranged at opposite ends of the pressing piece. The pressing piece may be extending downward.

[0008] The elastic support piece may have a tip end fixed to a circuit board stored within the electronic appliance.

[0009] A fire alarm device may include the push button structure noted above.

[0010] With such configuration, when the operating piece is not pushed, the second edge of the operating piece is kept spaced apart from the operating piece support portion of the button frame by a resilient force of the elastic support piece. In this state, the switch is not activated. If the operating piece is pushed, the second edge of the operating piece is brought into contact with the operating piece support portion of the button frame against the resilient force of the elastic support piece (the push button is supported at two points rather than one point). Thus, the operating piece is supported on the operating piece support portion. The first edge and the pressing piece are pushed down about the second edge as a fulcrum to activate the switch. Accordingly, the switch can be turned on and off with a reduced pushing force. The first edge of the operating piece is further pushed down about the second edge as a fulcrum after the second edge of the operating piece is brought into contact with the operating piece support portion. This prevents the pressing piece from wobbling when pushed down and eliminates instability in the switch operation.

[0011] In the configuration in which the operating piece includes a pair of elastic support pieces arranged at opposite ends of the first edge of the operating piece and the pressing piece arranged between the elastic support pieces to extend downward from the first edge of the operating piece, the elastic support pieces are not laterally distorted but are vertically flexed like a bow when the operating piece is pushed. Accordingly, there is provided an effect that the pressing piece is pressed downward in

a reliable manner. In addition, it is possible to obtain a good sense of operation even when the operating piece has an increased size.

[0012] In the configuration in which the elastic support piece has a tip end fixed to a circuit board stored within the electronic appliance, the circuit board is used as a member for fixing the elastic support pieces. It is therefore possible to reduce the number of parts.

[0013] In the push button structure of the present invention, it is possible to improve the sense of operation of the push button for receiving an alarm stopping operation and to reliably activate the switch provided within the electronic appliance. This makes it possible to provide a fire alarm device having an increased quality.

Brief Description of the Drawings

[0014]

Figs. 1A through 1C are partial vertical section views showing an electronic appliance employing the present invention.

Fig. 2 is an overall perspective view of the electronic appliance employing the present invention.

Fig. 3 is an exploded perspective view of the electronic appliance employing the present invention.

Figs. 4A and 4B are exploded perspective views illustrating how to attach a push button to the electronic appliance.

Detailed Description of the Preferred Embodiments

[0015] Figs. 1A through 1C are partial vertical section views showing an electronic appliance employing the present invention, e.g., a wall-fixed heat-type fire alarm device 1, which views are taken along the center of a push button. Fig. 2 is an overall perspective view of the fire alarm device 1, in which view a push button is provided in the front lower portion of the fire alarm device 1.

[0016] As shown in Fig. 3, the fire alarm device 1 is of a wall-fixed type fixed to a wall surface through a bracket 15. The fire alarm device 1 includes a base panel 11, a main board 12, a body panel 13, a cover panel 14 and the like. The bracket 15, the base panel 11 and the body panel 13 are resin-molded products. The cover panel 14 is a resin-molded product provided with a sound-passing metal net. The main board 12 is, e.g., a printed circuit board made of glass fibers, epoxy resin, paper or other suitable materials.

[0017] An airflow introducing hole 11a for introducing an heat-carrying airflow therethrough, a power supply battery storing portion 11b and a main board storing portion 11c are formed in the base panel 11. On the rear surface of the base panel 11, there are formed engagement portions engaging with engagement claws 15a formed in the bracket 15. A heat sensing element 12a such as a thermistor or the like, a microcomputer, a sound output circuit, a switch 12b and various kinds of electronic

parts such as a light emitting diode and the like are mounted on the main board 12. A metal component 12c for holding one or more (e.g., four) power supply batteries is fixedly secured to the main board 12. The heat sensing element 12a is mounted to protrude from the main board 12 so that the heat sensing element 12a can be positioned just below the airflow introducing hole 11a when the fire alarm device 1 is fixed to a wall surface. A speaker 18 connected to the sound output circuit is attached to the body panel 13. In addition to the engagement claws 15a, screw holes 15b, through which screws are inserted to fix the base panel 11 to the wall surface, are formed in the bracket 15. The fire alarm device 1 is installed on the wall surface by fixing the bracket 15 to the wall surface and then bringing the engagement portions of the base panel 11 into engagement with the engagement claws 15a of the bracket 15.

[0018] A push button 16 serves as an operation unit for receiving an alarm stopping operation or other operations. The push button 16 includes an operating piece 16a having an operating surface 16g to be pressed by a finger. The push button 16 is fitted to a button frame 19 of the body panel 13 so that the operating surface 16g can be exposed to the outside. The push button 16 is a molded product made of, e.g., a fiber-reinforced plastic. The push button 16 further includes a pressing piece 16b and a pair of elastic support pieces 16c, both of which are protrudingly formed in an upper edge 16e of the operating piece 16a. Each of the elastic support pieces 16c is formed into a substantially U-like shape and is configured to generate an elastic restoring force for returning the operating surface 16g back to the initial position after a finger pressing force is removed from the operating surface 16g. The respective portions of the push button 16 may be one-piece molded or may be independently formed and then assembled together. The pressing piece 16b is arranged in alignment with the switch 12b mounted on the main board 12. If the operating piece 16a is pushed, the pressing piece 16b presses the switch 12b.

[0019] In the illustrated example, the elastic support pieces 16c are provided at the opposite ends of the upper edge 16e of the operating piece 16a. The pressing piece 16b is arranged between the elastic support pieces 16c to extend toward the main board 12. This ensures that, when the operating piece 16a is pushed, the elastic support pieces 16c are not laterally distorted but are flexed like a bow (downward in Fig. 1). Accordingly, there is provided an effect that the pressing piece 16b is pressed downward in a reliable manner. In addition, it is possible to obtain a good sense of operation even when the operating piece 16a has an increased size.

[0020] The fire alarm device 1 further includes a light guide 17 made of a transparent resin. The light guide 17 serves to guide the light of the light emitting diode mounted on the main board 12 to an illuminating hole 16d formed in the push button 16. The light emitting diode is turned on or repeatedly turned on and off depending on the operating condition of the fire alarm device 1. The

light emitted from the light emitting diode can be visually perceived and confirmed through the illuminating hole 16d.

[0021] The fire alarm device 1 further includes an emblem 20, a decorating part, on which a type number and a manufacturer logo are printed.

[0022] Description will now be made on the basic operation of the push button 16.

[0023] Fig. 1A illustrates a state that the push button 16 is not pushed. In this state, the lower edge 16f opposite to the upper edge 16e of the operating piece 16a having the elastic support pieces 16c is kept spaced apart, by the elastic support pieces 16c, from the operating piece support portion 19a formed in the button frame 19.

[0024] If the operating piece 16a is pushed by a finger in this state, the lower edge 16f of the operating piece 16a moves downward against the resilient forces of the elastic support pieces 16c and comes into contact with the operating piece support portion 19a as illustrated in Fig. 1B.

[0025] If the operating piece 16a is further pushed by a finger in this state, the lower edge 16f of the operating piece 16a is supported on the operating piece support portion 19a. The upper edge 16e of the operating piece 16a is pushed downward using the operating piece support portion 19a as a fulcrum. Thus, the pressing piece 16b is moved downward, thereby pressing and activating the switch 12b. If the pushing force of a finger is removed from the operating piece 16a after activating the switch 12b, the upper edge 16e and the lower edge 16f of the operating piece 16a are moved upward by the resilient forces of the elastic support pieces 16c.

[0026] The push button structure of the present embodiment is configured to push down the pressing piece 16b under the principle stated above. Therefore, the switch 12b can be turned on and off with a reduced pushing force. The upper edge 16e of the operating piece 16a is pushed down in a state that the lower edge 16f of the operating piece 16a is brought into contact with the operating piece support portion 19a and fixed in that position. This prevents the pressing piece 16b from wobbling when pushed down and eliminates instability in the switch operation.

[0027] Figs. 4A and 4B are exploded perspective views illustrating how to attach the push button 16 to the electronic appliance. As shown in Figs. 4A and 4B, the tip ends of the elastic support pieces 16c are formed into cylindrical portions which have fixing holes defined at the central areas thereof. Positioning protrusions are formed on the rear surface of the body panel 13 in alignment with the fixing holes. The cylindrical portions of the elastic support pieces 16c are inserted between the main board 12 and the body panel 13 in a state that the positioning protrusions of the body panel 13 are fitted to the fixing holes of the elastic support pieces 16c. As a result, the push button 16 is attached to the electronic appliance. If the main board 12 is used as a member for fixing the elastic support pieces 16c as set forth above, it becomes

possible to reduce the number of parts.

[0028] The fire alarm device 1 has a function of repeatedly performing, at a specified time interval, a standby mode in which the operation of the heat sensing element 12a is stopped to reduce power consumption and a monitoring mode in which the heat sensing element 12a is operated to monitor occurrence of fire. For example, the standby mode may be performed for thirty seconds and the monitoring mode for one second, which time period can be arbitrarily changed if needed. In the monitoring mode, the heat sensing element 12a is operated a specified number of times to measure an ambient temperature. The heat sensing element 12a determines occurrence of fire depending on how many times the measured temperature has exceeded a predetermined value. If it is determined that fire has occurred, the fire alarm device 1 begins to output a fire alarming sound and turns on the light emitting diode. The fire alarming sound continues to be outputted until an alarm stopping operation is made by the push button 16. In addition, the output voltage of the power supply batteries is monitored at a specified time interval. If the output voltage is lower than a predetermined value, the light emitting diode is repeatedly turned on and off to urge a user to replace the batteries.

[0029] The description made above is directed to an example in which the present invention is applied to the fire alarm device 1. In the fire alarm device 1, the push button 16 having a large size is employed to make it easy to perform the alarm stopping operation. In the push button structure of the present invention, the sense of operation remains superior even if the push button 16 is formed into a large size. Moreover, the switch 12b provided within the electronic appliance can be reliably activated by pressing the push button 16. The push button structure of the present invention may be applied to different kinds of electronic appliances other than the fire alarm device 1. For example, the push button structure of the present invention may be used as an alarm stopping button of an alarm clock.

[0030] While one specific embodiment of the present invention has been described above, the present invention is not limited thereto. It will be apparent to those skilled in the art that the present invention can be changed or modified in many different forms without departing from the scope of the invention defined in the appended claims. The foregoing description and the attached drawings should be construed not to limit the present invention but to merely illustrate the present invention.

Claims

1. A push button structure for an electronic appliance, comprising a push button including an operating piece, a pressing piece and an elastic support piece, the operating piece having an operating surface, the pressing piece and the elastic support piece being

provided at a first edge of the operating piece, the push button being fitted in a button frame provided in the electronic appliance with the operating surface of the operating piece exposed to the outside, the push button being configured such that, when the operating surface is pushed, the pressing piece is moved down to activate a switch provided in the electronic appliance, **characterized in that:**

the button frame has an operating piece support portion; and
 the push button is configured such that, when the operating surface is not pushed, a second edge of the operating piece which is opposite to the first edge is kept spaced apart from the operating piece support portion of the button frame by a resilient force of the elastic support piece and further that, when the operating surface is pushed, the second edge of the operating piece is brought into contact with the operating piece support portion of the button frame against the resilient force of the elastic support piece and then the pressing piece is moved down about the second edge as a fulcrum to activate the switch.

2. The push button structure of claim 1, wherein the elastic support pieces is arranged at each of opposite sides of the pressing piece, the pressing piece extending downward from the first edge of the operating piece.
3. The push button structure of claim 1 or 2, wherein the elastic support piece has a tip end fixed to a circuit board stored within the electronic appliance.
4. A fire alarm device comprising the push button structure of any one of claims 1 to 3.

40

45

50

55

FIG. 1A

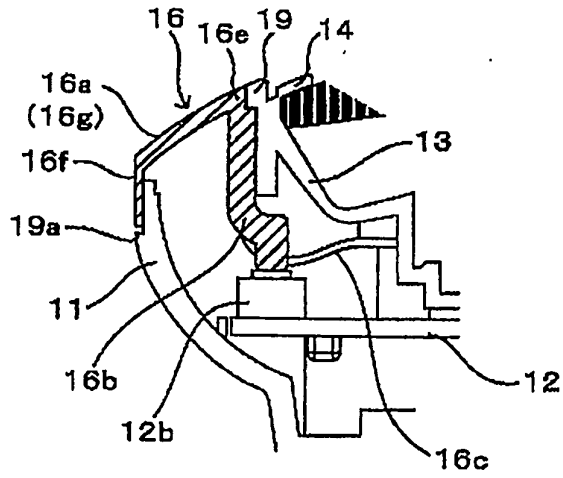

FIG. 1B

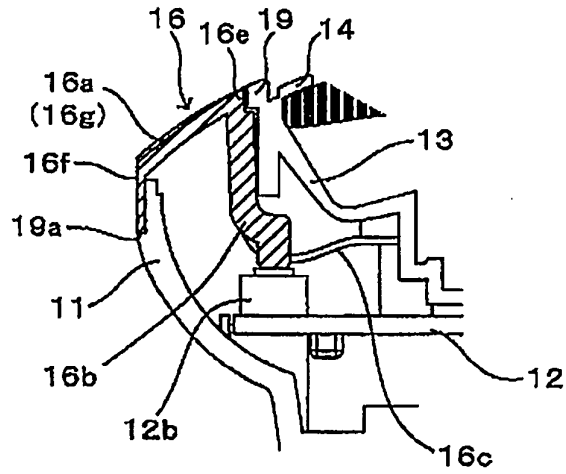

FIG. 1C

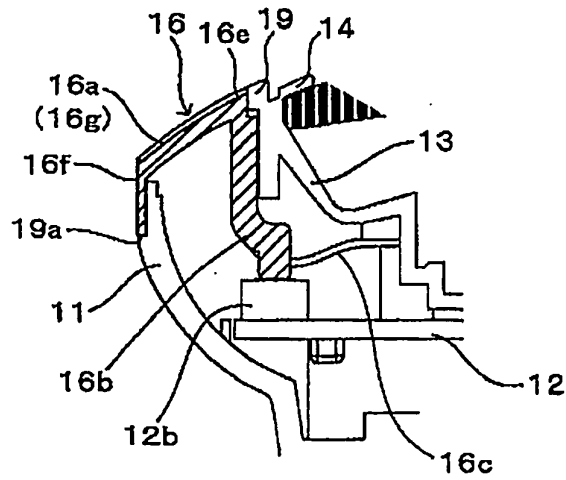

FIG. 2

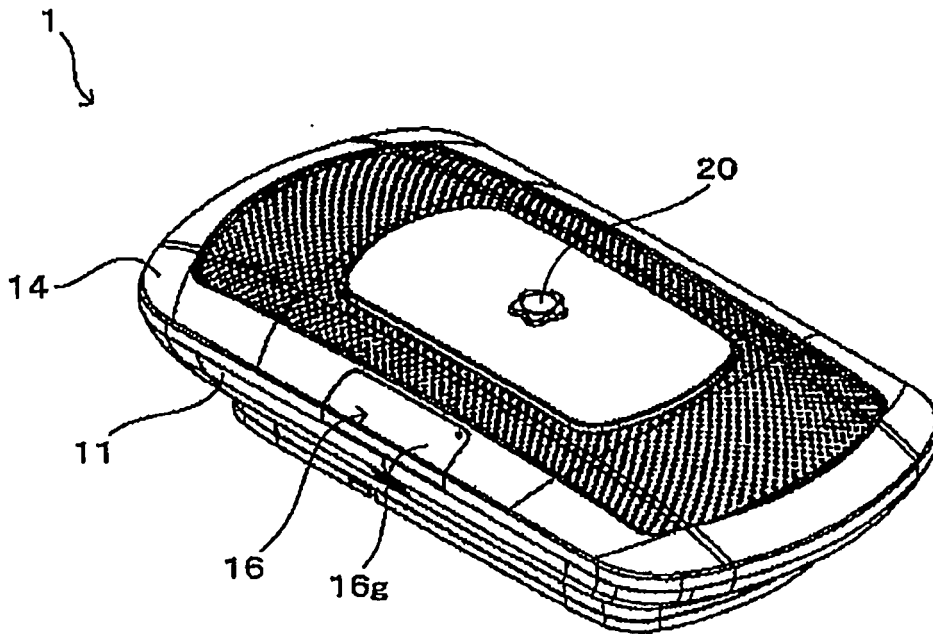

FIG. 3

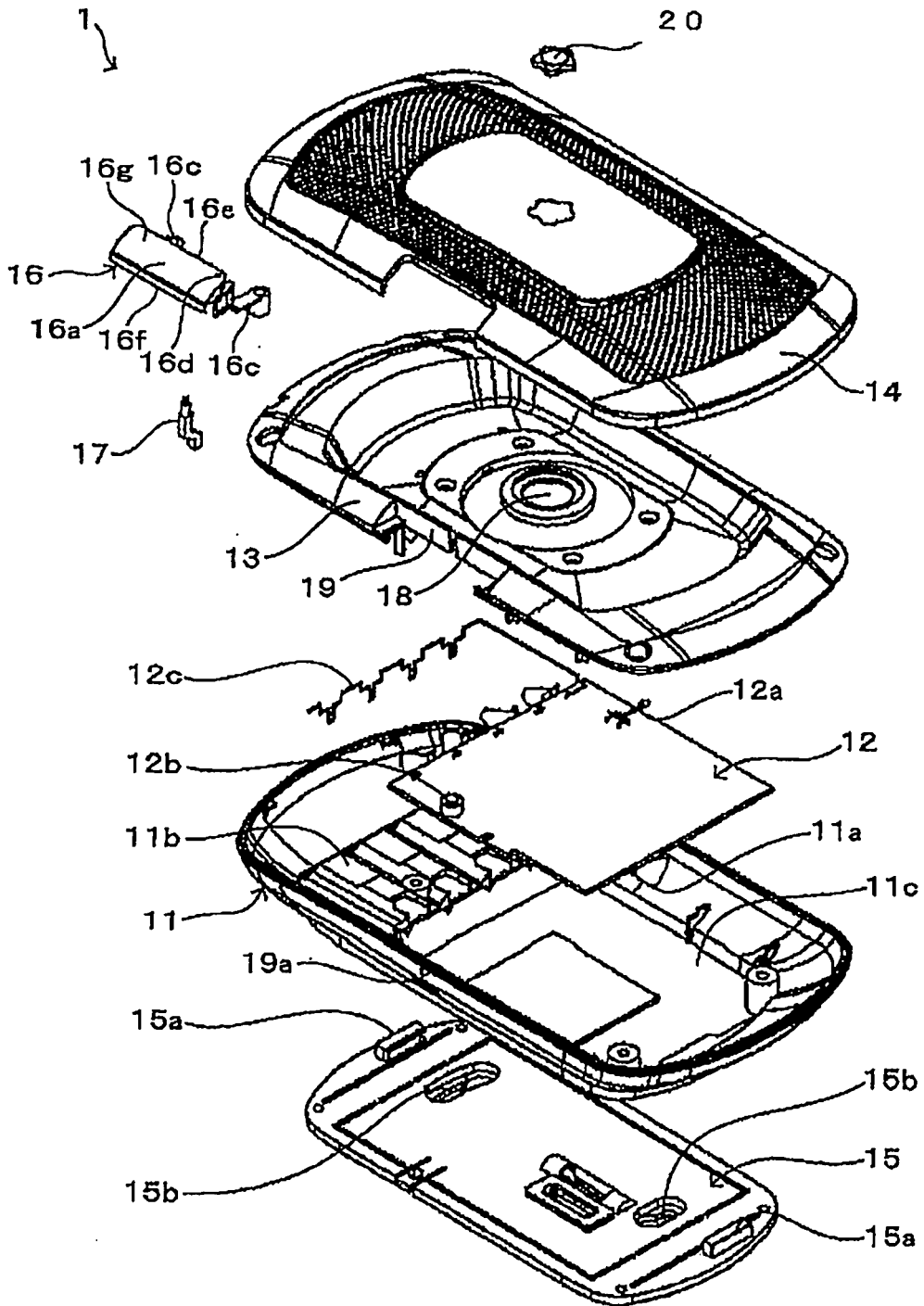

FIG. 4A

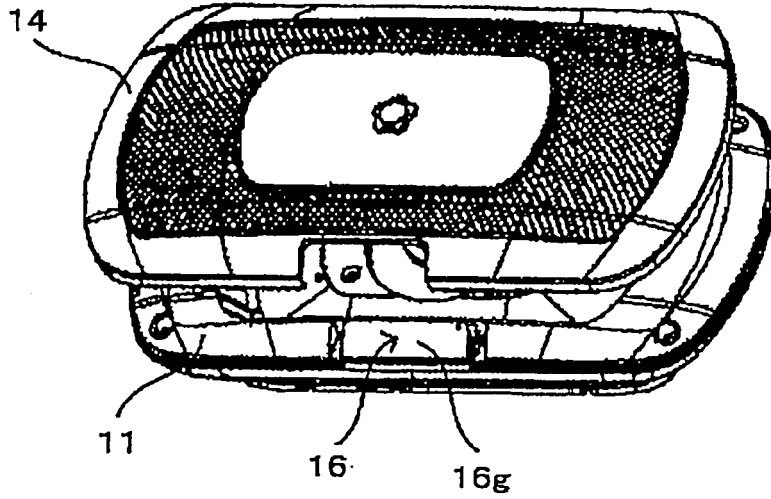
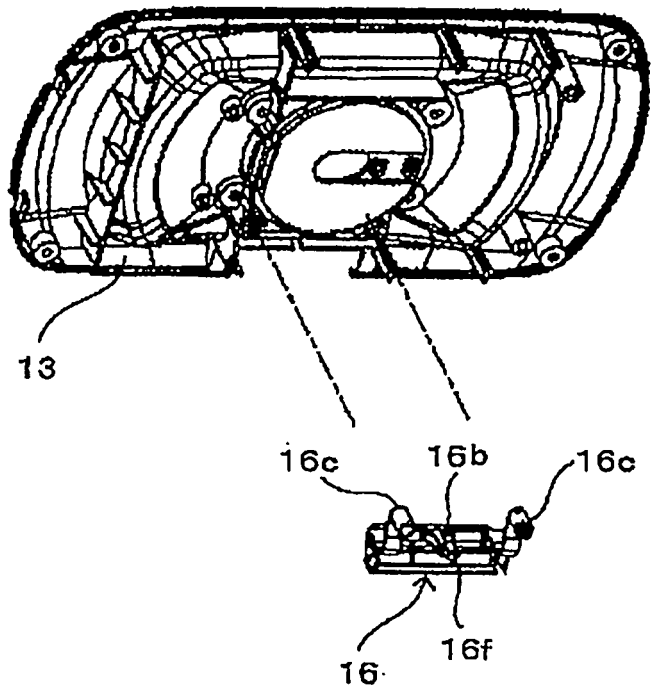

FIG. 4B



INTERNATIONAL SEARCH REPORT

International application No.

PCT/IB2010/001491

A. CLASSIFICATION OF SUBJECT MATTER H01H21/00(2006.01)i, H01H25/00(2006.01)i		
According to International Patent Classification (IPC) or to both national classification and IPC		
B. FIELDS SEARCHED		
Minimum documentation searched (classification system followed by classification symbols) H01H21/00, H01H25/00		
Documentation searched other than minimum documentation to the extent that such documents are included in the fields searched Jitsuyo Shinan Koho 1922-1996 Jitsuyo Shinan Toroku Koho 1996-2010 Kokai Jitsuyo Shinan Koho 1971-2010 Toroku Jitsuyo Shinan Koho 1994-2010		
Electronic data base consulted during the international search (name of data base and, where practicable, search terms used)		
C. DOCUMENTS CONSIDERED TO BE RELEVANT		
Category*	Citation of document, with indication, where appropriate, of the relevant passages	Relevant to claim No.
A	JP 9-306291 A (Mitsubishi Electric Corp.), 28 November 1997 (28.11.1997), entire text; all drawings (Family: none)	1-4
A	Microfilm of the specification and drawings annexed to the request of Japanese Utility Model Application No. 161599/1985(Laid-open No. 69348/1987) (Sanyo Electric Co., Ltd.), 01 May 1987 (01.05.1987), entire text; all drawings (Family: none)	1-4
<input checked="" type="checkbox"/> Further documents are listed in the continuation of Box C. <input type="checkbox"/> See patent family annex.		
* Special categories of cited documents: "A" document defining the general state of the art which is not considered to be of particular relevance "E" earlier application or patent but published on or after the international filing date "L" document which may throw doubts on priority claim(s) or which is cited to establish the publication date of another citation or other special reason (as specified) "O" document referring to an oral disclosure, use, exhibition or other means "P" document published prior to the international filing date but later than the priority date claimed "I" later document published after the international filing date or priority date and not in conflict with the application but cited to understand the principle or theory underlying the invention "X" document of particular relevance; the claimed invention cannot be considered novel or cannot be considered to involve an inventive step when the document is taken alone "Y" document of particular relevance; the claimed invention cannot be considered to involve an inventive step when the document is combined with one or more other such documents, such combination being obvious to a person skilled in the art "&" document member of the same patent family		
Date of the actual completion of the international search 21 October, 2010 (21.10.10)		Date of mailing of the international search report 02 November, 2010 (02.11.10)
Name and mailing address of the ISA/ Japanese Patent Office		Authorized officer
Facsimile No.		Telephone No.

Form PCT/ISA/210 (second sheet) (July 2009)

INTERNATIONAL SEARCH REPORT

International application No. PCT/IB2010/001491
--

C (Continuation). DOCUMENTS CONSIDERED TO BE RELEVANT		
Category*	Citation of document, with indication, where appropriate, of the relevant passages	Relevant to claim No.
A	JP 2008-171683 A (Matsushita Electric Works, Ltd.), 24 July 2008 (24.07.2008), entire text; all drawings (Family: none)	1-4

Form PCT/ISA/210 (continuation of second sheet) (July 2009)

REFERENCES CITED IN THE DESCRIPTION

This list of references cited by the applicant is for the reader's convenience only. It does not form part of the European patent document. Even though great care has been taken in compiling the references, errors or omissions cannot be excluded and the EPO disclaims all liability in this regard.

Patent documents cited in the description

- JP 2008171683 A [0002]