

(19)



(11)

**EP 2 458 052 B1**

(12)

**EUROPEAN PATENT SPECIFICATION**

(45) Date of publication and mention  
of the grant of the patent:  
**17.06.2015 Bulletin 2015/25**

(51) Int Cl.:  
**D04B 35/06 (2006.01)**

(21) Application number: **11009237.6**

(22) Date of filing: **22.11.2011**

(54) **Compound needle for flatbed knitting machine**

Schiebernadel für Flachstrickmaschinen

Aiguille de type compound pour machine à tricoter rectiligne

(84) Designated Contracting States:  
**AL AT BE BG CH CY CZ DE DK EE ES FI FR GB  
GR HR HU IE IS IT LI LT LU LV MC MK MT NL NO  
PL PT RO RS SE SI SK SM TR**

(30) Priority: **22.11.2010 JP 2010260511**

(43) Date of publication of application:  
**30.05.2012 Bulletin 2012/22**

(73) Proprietor: **Shima Seiki Mfg., Ltd.  
Wakayama-shi,  
Wakayama 641-8511 (JP)**

(72) Inventor: **Sonomura, Minoru  
Wakayama 641-8511 (JP)**

(74) Representative: **Wimmer, Hubert  
WAGNER & GEYER  
Gewürzmühlstrasse 5  
80538 München (DE)**

(56) References cited:  
**EP-A1- 1 229 158 GB-A- 2 237 035**

**EP 2 458 052 B1**

Note: Within nine months of the publication of the mention of the grant of the European patent in the European Patent Bulletin, any person may give notice to the European Patent Office of opposition to that patent, in accordance with the Implementing Regulations. Notice of opposition shall not be deemed to have been filed until the opposition fee has been paid. (Art. 99(1) European Patent Convention).

## Description

[Technical Field]

**[0001]** The present invention relates to a compound needle for a flatbed knitting machine, the compound needle includes a needle body being put in a needle groove, the needle grooves arranged in line on a needle bed, the needle body having a hook to move to and back from a needle bed gap to which a tip end of the needle bed is faced and a slider having a tongue to open and close the hook by relative movement to the needle body.

[Background Art]

**[0002]** Conventionally, a flatbed knitting machine knits a fabric, while knitting needles are put in needle grooves arranged in line on a needle bed, hooks provided on front ends of the knitting needles are caused to move to and back from a needle bed gap to which a tip end of the needle bed is faced, and a knitting yarn is fed to the hooks at the needle bed gap. For the knitting needles, compound needles are used to open and close hooks with sliders as well as a latch needles are used to open and close hooks with latches.

**[0003]** In the flatbed knitting machine, two needle beds are provided on the front and back side across the needle bed gap and are faced to each other, each needle bed is tilted in such a way that the needle bed gap side of the needle bed is high and the needle bed becomes lower as apart from the needle bed gap. In the following explanation, the direction is determined relative to the individual needle bed in such a way that the needle bed gap side of the needle bed is the front, the side where the needle bed is apart from the needle bed gap is the back, and the direction in which the knitting needle moves in the needle groove is the longitudinal direction. The vertical direction is determined in such a way that the direction in which the needle bed floats in the needle groove is the upper side and the direction in which the needle bed sinks is the lower side.

**[0004]** Figs. 5 show schematic structures of essential portions of a conventional compound needle 1 in a state in which the compound needle 1 is put in a needle groove (for example, see Patent Literature 1). However, structures, related to a needle bed and a needle groove, are not shown in the drawings. The compound needle 1 includes a needle body 2 and a slider 3. The slider 3 includes two blades 4 and a base body 5. The compound needle 1 also includes a needle jack 6. Main components of the compound needle 1 are formed by processing a metal plate.

**[0005]** The needle body 2 has a hook 2a at the front end and a needle shank 2b subsequent to the hook 2a. The needle shank 2b is provided with a slider groove 2c at a middle part in a widthwise direction vertical to the paper surface. The slider groove 2c has a bottom surface 2d. A notch 2e is provided on side walls erected from

both sides of the bottom surface 2d in the widthwise direction, and a fork portion 2f is formed on the upper portion of the notch 2e. A joining portion 2g is provided on a rear end side of the needle body 2. At least the lower portions of the blades 4 are put in the slider groove 2c of the needle body 2 with the two blades 4 laid on each other. A tongue 4a is provided on the front end of the blade 4, and an arm 4b is extended behind the rear side of the tongue 4a. A joining portion 4c is provided near the rear end of the arm 4b, and a swing stopping protrusion 4d is provided near the front end. The base body 5 is provided with a protrusion putting in portion 5a that puts in the swing stopping protrusion 4d of the blade 4 near the front end, and the arm 5b is extended to rearward. The base body 5 also has a joining portion 5c to be joined to the joining portion 4c of the blade 4, so that the blade 4 and the base body 5 are joined to each other to function as the slider 3. A joining portion 6a is fit into the joining portion 2g provided near the rear end of the needle body 2, the joining portion 6a being provided on the front end of the needle jack 6.

**[0006]** Fig. 5(a) shows a state in which the hook opening of the hook 2a is closed with the tongue 4a. Fig. 5(b) shows a clearing state in which the slider 3 moves back with respect to the needle body 2 and a stitch retained on the hook 2a can be moved from the opened hook opening of the hook 2a to the tongue 4a. It is necessary that the tongue 4a be sunk in the slider groove 2c to cause no trouble such as the tongue 4a being hooked on a stitch moving back along the needle shank 2b. In the compound needle 1 shown in the drawings, the upper portions of the blades 4 subsequent to the tongue 4a are opened on both sides in the widthwise direction to form a curving portion 4e for convenience as in receiving a stitch retained on the hook 2a by a transfer jack form above. In Fig. 5(b), the curving portion 4e is guided to the notch 2e where the fork portion 2f is faced, and the curving portion 4e is pressed downward on the lower side of the fork portion 2f to sink the tongue 4a. It is noted that the tongue 4a can move to the needle bed gap over the hook 2a in the slider 3 using two blades 4.

**[0007]** Fig. 5(c) shows the cross sectional structure seen from a cutting surface line C-C in Fig. 5(b). Since the two blades 4 are laid on each other, the curving portion 4e is opened to both sides of a center line 1a. The notch 2e and the fork portion 2f are provided on two side walls of the slider groove 2c provided on the needle shank 2b to press the curving portion 4e downward.

[Citation List]

[Patent literature]

**[0008]** [Patent Literature 1] Japanese Patent No. 3577038 corresponding to EP 1 229 518 A.

[Summary of Invention]

[Technical Problem]

**[0009]** As shown in Fig. 5(c), in the needle shank 2b of the needle body 2, the slider groove 2c is formed at a middle part in the widthwise direction to guide the curving portion 4e of the blade 4 to the notch 2e provided on the side wall, and the tongue 4a is sunk in the slider groove 2c at a clearing time. Since the slider groove 2c is formed by processing a groove from the top surface side of the needle body 2, the fork portion 2f is processed at the same time to be the wall in a thin plate. The blade 4 is also in a thin plate, and the underside of the fork portion 2f engages with the curving portion 4e with the thin plates.

**[0010]** In the flatbed knitting machine, it is called a fine gauge when the arrangement density of the knitting needles is increased and the arrangement pitch is reduced. In the fine gauge, the width of the needle groove is also reduced, and the width of the needle body 2 that can be put in the needle groove is also reduced. In the structure of using the curving portion 4e for pressing at a clearing time as shown in Figs. 5, the thickness of the side wall of the needle shank 2b and the plate thickness of the blade 4 become thin, so that it becomes difficult to contact the underside of the fork portion 2f with the top end of the curving portion 4e.

**[0011]** It is an object of the present invention to provide a compound needle for a flatbed knitting machine that can reliably guide tongues to be sunk in a slider groove at a clearing time, in which a slider having tongues formed with two blades is moved back with respect to a needle body.

[Solution to Problem]

**[0012]** The present invention is a compound needle for a flatbed knitting machine, comprising:

a needle body having a hook at a front end and a slider groove formed on a needle shank extending rearward from the hook; and  
 a slider having two blades, each blade being provided with a tongue formed at a front portion, the blades being capable of hanging a stitch and at least a portion of the blades being put in the slider groove of the needle body to be guided in a front-rear direction, and the tongues opening and closing the hook by relative movement to the needle body, the needle body being provided with:

a closing portion, neighboring on a rear side of the hook and having a bottom surface in a section of the slider groove to put in the tongues in a state where the front portion of the tongues closes the hook;

a clearing portion, formed so as to have a bottom surface in a portion of the slider groove to put in

head end portions of the tongues, and so as not to have bottom surface in a portion of the slider groove to put in rear side portions of the tongues backward of the head end portions of the tongues in a clearing state where the tongues move back with respect to the needle body on a rear side of the closing portion to open the hook and receive a stitch retreating from the hook; and

an overhanging portion, formed over the clearing portion so as to extend from rearward to frontward at a width covering at least the slider groove, and provided with a pressing portion on an under surface thereof; and

each of the two blades having:

an arm, extended on the rearward beyond the tongue so as to allow vertical movement of the tongue by elastic bending; and  
 a sloping portion, provided near a front end portion of the arm so as to project upward from the slider groove within a width thereof, to contact with the pressing portion on the under surface of the overhanging portion of the needle body, and to reduce a height from the frontward to the rearward.

**[0013]** Moreover, in the present invention, said blade has a curving portion at said front portion, neighboring to a rearward of said tongue and opening an upper end of the blade to an outward of the slider groove,

said arm is extended over the rearward beyond said overhanging portion of said needle body, and said sloping portion is formed on a down side to rearward beyond a front end of the arm.

**[0014]** Furthermore, in the present invention, a front portion of said blade is formed so that said tongue and a portion neighboring to the rearward of the tongue fall within the width of said slider groove,

on said needle body, the slider groove is formed with no bottom surface to the rearward beyond said overhanging portion, and  
 said sloping portion is formed on an up side to frontward beyond the front end of said arm.

[Advantageous Effects of Invention]

**[0015]** According to the present invention, the tongue is put in the clearing portion of the slider groove, in the clearing state in which the slider moves back with respect to the needle body to open the hook and the tongue receives a stitch retreating from the hook. Since the overhanging portion is formed above the clearing portion in such a way that the overhanging portion is extended from

the rear side of the needle body to the front side at the width covering at least the slider groove, the sloping portion of the blade is contacted with the pressing portion provided on the under surface of the overhanging portion, and the tongue is sunk in the slider groove with a pressing force. The tongue is pressed within the width of the slider groove, so that it is possible to reliably guide the tongue to be sunk in the slider groove even though the plate thickness of the needle body becomes thin.

**[0016]** The sloping portion is pressed by the pressing portion on the under surface of the overhanging portion, so that it is possible to eliminate the influence of processing on the under surface of the overhanging portion if the slider groove is processed from below the needle shank. The slider groove is bottomless in the clearing portion, so that it is possible that dust tends to be removed out of the inside of the slider groove and the possibility of malfunction caused by the clogging of dust is reduced.

**[0017]** Moreover, according to the present invention, the arm is extended on the rearward beyond the overhanging portion, so that it is possible to form the compound needle by readily combining the needle body with the slider from above, even though the curving portion is provided subsequent to the tongue. It is possible that the tongue is pressed and sunk in the slider groove at a clearing time with the sloping portion provided on the back side near the front end of the arm and the tongue is reliably pressed within the width of the slider groove.

**[0018]** Furthermore, according to the present invention, the blade is not provided with the curving portion to swell outward beyond the width of the slider groove, so that it is possible to readily assemble the compound needle in which the blade is inserted forward as passing below the overhanging portion, even though the slider groove is formed on the rearward beyond the overhanging portion.

#### [Brief Description of Drawings]

#### [0019]

[Fig. 1] Figs. 1 are side views and a front cross sectional view showing a schematic structure of a compound needle 11 according to an example of the present invention.

[Fig. 2] Figs. 2 are side views showing main components structuring the compound needle 11 shown in Fig. 1 and a combination thereof.

[Fig. 3] Figs. 3 are partial side views showing a schematic structure of a compound needle 21 according to another example of the present invention.

[Fig. 4] Figs. 4 are side views showing main components structuring the compound needle 21 shown in Figs. 3 and a combination thereof.

[Fig. 5] Figs. 5 are partial side views and a front cross sectional view showing a schematic structure of a conventional compound needle 1.

#### [Description of Embodiments]

**[0020]** In the following, Figs. 1 and Figs. 2 show a schematic structure of a compound needle 11 of a flatbed knitting machine according to an example of the present invention. Figs. 3 and Figs. 4 show a schematic structure of a compound needle 21 of a flatbed knitting machine according to another example of the present invention. Although matters common to the compound needle 11 and the compound needle 21 are collectively explained with reference numerals and signs marked on the components of the compound needle 11 and the compound needle 21, portions for use in the respective examples are not always be allowed to use in combination.

**[0021]** In the drawings, in some cases, portions corresponding to the portions previously explained are designated the same reference numerals and signs, and the overlapping explanations are omitted. In addition, in some cases, mention is made of reference numerals and signs that are not marked in the drawings for explanation but marked in the drawings previously explained.

#### [Example]

**[0022]** Figs. 1 and Figs. 3 show the schematic structures of the compound needles 11, 21 according to the examples of the present invention. The compound needle 11 includes needle body 12 and slider 13, the slider 13 including blade 14 and base body 15. The compound needle 21 includes needle body 22 and slider 23, the slider 23 including blade 24 and base body 25. The compound needle 11 also includes a needle jack 6. Although the compound needle 21 also includes a needle jack 6 as similar to the compound needle 11, the needle jack 6 is omitted in the drawings. In the needle bodies 12, 22, slider grooves 12c, 22c are respectively provided on needle shanks 12b, 22b subsequent to hooks 12a, 22a of the front ends. Although the slider grooves 12c, 22c have bottom surfaces 12d, 22d near the front ends respectively, the bottom surfaces 12d, 22d are not provided on the rearward, and overhanging portions 12e, 22e are formed above the slider grooves 12c, 22c so as to be overhung from the rearward. The overhanging portions 12e, 22e are separated downside by spaces to the top surfaces of the needle shanks 12b, 22b, on which the slider grooves 12c, 22c are formed, and pressing portions 12f, 22f are provided on the underside of the overhanging portions 12e, 22e. Joining portions 12g, 22g are respectively provided on the rear portions of the needle bodies 12, 22, and joined to a joining portion 6a of the needle jack 6.

**[0023]** At least the lower portions of the blades 14, 24 are put in the slider grooves 12c, 22c with two blades laid on each other, in which tongues 14a, 24a are provided on the front end and arms 14b, 24b are provided behind the rearward of the tongues 14a, 24a, respectively. Joining portions 14c, 24c are provided near the rear end of the arm 14b, 24b and joined to joining portion 15c, 25c

provided near the front ends of the arms 15b, 25b of the base body 15, 25. In the compound needle 11, a curving portion 14e is provided subsequent to the tongue 14a. Sloping portions 14f, 24f are respectively provided subsequent to the tongues 14a, 24a, in which the height of the sloping portions 14f, 24f are reduced from the forward to the rearward. These portions are provided at the top ends of the arms 14b, 24b as head portions 14g, 24g of the blades 14, 24 and capable of vertically moving in the slider grooves 12c, 22c by the bending of the arms 14b, 24b, respectively.

**[0024]** Fig. 1(a) and Fig. 3(a) show a state in which the hook opening of the hooks 12a, 22a are closed with the tongues 14a, 24a. The head portions 14g, 24g of the blades 14, 24 are put in closing portions 12h, 22h of the slider grooves 12c, 22c in which the head portions 14g, 24g are floating in the slider grooves 12c, 22c by upward force from the bottom surfaces 12d, 22d and the head ends of the tongues 14a, 24a contact with the tip ends of the hooks 12a, 22a to close the hook openings. The upper portion of the arm 14b of the compound needle 11 is inserted into an arm groove 15d provided on the base body 15, and a swing of the slider groove 12c in the widthwise direction is suppressed in this state. A swing stopping protrusion 24d at the front end of the arm 24b of the compound needle 21 is put in a protrusion putting in portion 25a provided at the front end of the base body 25, and a swing of the slider groove 22c in the widthwise direction is suppressed in this state. It is also possible to move the tongues 14a, 24a forward beyond the hooks 12a, 22a.

**[0025]** Figs. 1(b) and 3(b) show a state at a clearing time. The head portions 14g, 24g of the blades 14, 24 are put in clearing portions 12i, 22i of the slider grooves 12c, 22c, and the sloping portions 14f, 24f are pressed with the pressing portions 12f, 22f on the under surfaces of the overhanging portions 12e, 22e. The tongues 14a, 24a are sunk in the slider grooves 12c, 22c, so that stitches can smoothly move back along the needle shanks 12b, 22b, respectively. Since the arm 14b of the compound needle 11 is extended on the rearward beyond the overhanging portion 12e, it is possible to form the compound needle 11 by combining the needle body 12 with the slider 13 from above even though the curving portion 14e is provided subsequent to the tongue 14a. Since the sloping portion 14f is formed on the down side, which is the rearward beyond the front end of the arm 14b, it is possible to reliably press the sloping portion 14f with the pressing portion 12f on the under surface of the overhanging portion 12e even though the arm 14b passes over the overhanging portion 12e. The compound needle 21 is not provided with a portion corresponding to the curving portion 14e that swells outward beyond the width of the slider groove 22c. Consequently, in the compound needle 21, it is possible to readily assemble the blades 24 in case the blade 24 is inserted forward as passing below the overhanging portion 22e, even though the slider groove 22c is formed to the rearward beyond the over-

hanging portion 22e.

**[0026]** Fig. 1(c) shows a cross sectional structure seen on a cutting surface line C-C in Fig. 1(b). Since the overhanging portion 12e is formed along the entire width of the needle shank 12b, it is possible that the upper ends of the sloping portions 14f of the blades 14 in two layers are readily contacted with the overhanging portion 12e to reliably press the sloping portion 14f with the pressing portion 12f on the under surface of the overhanging portion 12e from above. The slider groove 12c is processed from above the needle shank 12b in the closing portion 12h, whereas the slider groove 12c is processed from below the needle shank 12b in the clearing portion 12i. Since the clearing portion 12i is opened downward, it is also possible to remove dust out of the inside of the slider groove 12c in operation as a knitting needle. Also for the compound needle 21, in a cross sectional structure of the clearing portion 22i, the overhanging portion 22e is similarly formed along the entire width of the needle shank 22b, and it is possible to readily press the sloping portions 24f of the blades 24 in two layers with the pressing portions 22f. Since the slider groove 22c formed similarly to the slider groove 12c of the compound needle 11 is also opened downward in the clearing portion 22i, it is possible to readily perform processing and removal of dust.

**[0027]** Figs. 2 and Figs. 4 respectively show structures of main components of the compound needles 11, 21 shown in Figs. 1 and Figs. 3. Fig. 2(a) shows a structure of the blade 14 and the base body 15. On the rearward of the base body 15, the arm 15b is extended, and a butt 15e is erected to receive the drive for the slider 13. Fig. 2(b) shows the blade 14 and the base body 15 for the slider 13 in combination by joining the joining portions 14c, 15c to each other. Fig. 2(c) shows a state in which the needle body 12 and the needle jack 6 are combined. The needle body 12 performs main operations for the knitting needle with the drive to the butt 6b provided on the needle jack 6. Fig. 4(a) shows structures of the blade 24 and the base body 25. On the rearward of the base body 25 of Figs. 3, the arm 25b is extended, and the butt is provided to receive the drive for the slider 23, however, they are omitted in the drawing. Fig. 4(b) shows the blade 24 and the base body 25 for the slider 23 in combination by joining the joining portions 24c, 25c to each other. Fig. 4(c) shows the needle body 22.

[Reference Signs List]

**[0028]**

11, 21	Composite needle
12, 22	Needle body
12a, 22a	Hook
12b, 22b	Needle shank

12c, 22c	Slider groove	
12e, 22e	Overhanging portion	
12f, 22f	Pressing portion	5
12h, 22h	Closing portion	
12i, 22i	Clearing portion	
13, 23	Slider	10
14, 24	Blade	
14a, 24a	Tongue	15
14e	Curving portion	
14f, 24f	Sloping portion	20
15, 25	Base body	

#### Claims

1. A compound needle (11, 21) for a flatbed knitting machine, comprising:

a needle body (12, 22) having a hook (12a, 22a) at a front end and a slider groove (12c, 22c) formed on a needle shank (12b, 22b) extending rearward from the hook (12a, 22a); and a slider (13, 23) having two blades (14, 24), each blade (14, 24) being provided with a tongue (14a, 24a) formed at a front portion, the blades (14, 24) being capable of hanging a stitch and at least a portion of the blades (14, 24) being put in the slider groove (12c, 22c) of the needle body (12, 22) to be guided in a front-rear direction, and the tongues (14, 24) opening and closing the hook (12a, 22a) by relative movement to the needle body (12, 22), the needle body (12, 22) being provided with:

a closing portion (12h, 22h), neighboring on a rear side of the hook (12a, 22a) and having a bottom surface (12d, 22d) in a section of the slider groove (12c, 22c) to put in the tongues (14a, 24a) in a state where the front portion of the tongues (14a, 24a) closes the hook (12a, 22a);

a clearing portion (12i, 22i), formed so as to have a bottom surface (12d, 22d) in a portion of the slider groove (12c, 22c) to put in head end portions of the tongues (14a, 24a), **characterized in that** the needle body (12, 22) is further provided with a clearing portion (12i, 22i) formed so as not to have bottom

surface (12d, 25d) in a portion of the slider groove (12c, 22c) to put in rear side portions of the tongues (14a, 24a) backward of the head end portions of the tongues (14a, 24a) in a clearing state where the tongues (14a, 24a) move back with respect to the needle body (12, 22) on a rear side of the closing portion (12h, 22h) to open the hook (12a, 22a) and receive a stitch retreating from the hook (12a, 22a); and an overhanging portion (12e, 22e), formed over the clearing portion (12i, 22i) so as to extend from rearward to frontward at a width covering at least the slider groove (12c, 22c), and provided with a pressing portion (12f, 22f) on an under surface thereof; and

each of the two blades (14, 24) having:

an arm (14b, 24b), extended on the rearward beyond the tongue (14a, 24a) so as to allow vertical movement of the tongue (14a, 24a) by elastic bending; and a sloping portion (14f, 24f), provided near a front end portion of the arm (14b, 24b) so as to project upward from the slider groove (12c, 22c) within a width thereof, to contact with the pressing portion (12f, 22f) on the under surface of the overhanging portion (12e, 22e) of the needle body (12, 22), and to reduce a height from the frontward to the rearward.

2. The compound needle (11) for a flatbed knitting machine according to claim 1, **characterized in that** said blade (14) has a curving portion (14e) at said front portion, neighboring to a rearward of said tongue (14a) and opening an upper end of the blade (14) to an outward of the slider groove (12c), said arm (14b) is extended over the rearward beyond said overhanging portion (12e) of said needle body (12), and said sloping portion (14f) is formed on a down side to rearward beyond a front end of the arm (14b).
3. The compound needle (21) of a flatbed knitting machine according to claim 1, **characterized in that** a front portion of said blade (24) is formed so that said tongue (24a) and a portion neighboring to the rearward of the tongue (24a) fall within the width of said slider groove (22c), on said needle body (22), the slider groove (22c) is formed with no bottom surface (22d) to the rearward beyond said overhanging portion (22e), and said sloping portion (24f) is formed on an up side to front ward beyond the front end of said arm (24b).

## Patentansprüche

1. Schiebernadel (11, 21) für eine Flachstrickmaschine, umfassend:

einen Nadelkörper (12, 22) mit einem Haken (12a, 22a) an einem vorderen Ende und einer Schiebernut (12c, 22c), die an einem sich von dem Haken (12a, 22a) nach hinten erstreckenden Nadelschaft (12b, 22b) ausgebildet ist, und einen Schieber (13, 23) mit zwei Blättern (14, 24), wobei jedes Blatt (14, 24) mit einer an einem vorderen Teil ausgebildeten Zunge (14a, 24a) versehen ist, wobei die Blätter (14, 24) eine Masche aufhängen können und wenigstens ein Teil der Blätter (14, 24) in die Schiebernut (12c, 22c) des Nadelkörpers (12, 22) eingesetzt ist, um in einer Vorne-Hinten-Richtung geführt zu werden, und wobei die Zungen (14, 24) den Haken (12a, 22a) durch eine relative Bewegung zu dem Nadelkörper (12, 22) öffnen und schließen, wobei der Nadelkörper (12, 22) versehen ist mit:

einem Schließeteil (12h, 22h), der einer Rückseite des Hakens (12a, 22a) benachbart ist und eine Bodenfläche (12d, 22d) in einem Abschnitt der Schiebernut (12c, 22c) aufweist, um die Zungen (14a, 24a) in einen Zustand zu bringen, in dem der vordere Teil der Zungen (14a, 24a) den Haken (12a, 22a) schließt, und

einem Freigabeteil (12i, 22i), der derart ausgebildet ist, dass er eine Bodenfläche (12d, 22d) in einem Teil der Schiebernut (12c, 22c) aufweist, um Kopfendteile der Zungen (14a, 24a) einzusetzen, **dadurch gekennzeichnet, dass** der Nadelkörper (12, 22) weiterhin mit einem Freigabeteil (12i, 22i) versehen ist, der derart ausgebildet ist, dass er keine Bodenfläche (12d, 25d) in einem Teil der Schiebernut (12c, 22c) aufweist, um Rückseitenteile der Zungen (14a, 24a) hinter den Kopfendteilen der Zungen (14a, 24a) in einen Freigabezustand zu bringen, in dem sich die Zungen (14a, 24a) nach hinten in Bezug auf den Nadelkörper (12, 22) auf einer Rückseite des Schließteils (12h, 22h) bewegen, um den Haken (12a, 22a) zu öffnen und eine sich von dem Haken (12a, 22a) zurückziehende Masche zu empfangen, und

einen Überhangteil (12e, 22e), der über dem Freigabeteil (12i, 22i) ausgebildet ist, um sich von hinten nach vorne mit einer Breite zu erstrecken, die wenigstens die Schiebernut (12c, 22c) bedeckt, und der mit einem Drückteil (12f, 22f) an einer unteren Fläche versehen ist, und

wobei jede der zwei Blätter (14, 24) aufweist:

einen Arm (14b, 24b), der sich nach hinten über die Zunge (14a, 24a) hinaus erstreckt, um eine vertikale Bewegung der Zunge (14a, 24a) durch ein elastisches Biegen zu gestatten, und

einen Neigungsteil (14f, 24f), der an einem vorderen Endteil des Arms (14b, 24b) derart vorgesehen ist, dass er von der Schiebernut (12c, 22c) nach oben innerhalb der Breite derselben vorsteht, um den Drückteil (12f, 22f) an der unteren Fläche des Überhangteils (12e, 22e) des Nadelkörpers (12, 22) zu kontaktieren, um eine Höhe von vorn nach hinten zu reduzieren.

2. Schiebernadel (11) für eine Flachstrickmaschine nach Anspruch 1, **dadurch gekennzeichnet, dass:**

das Blatt (14) einen Krümmungsteil (14e) an dem vorderen Teil aufweist, der einem hinteren Ende der Zunge (14a) benachbart ist und ein oberes Ende des Blatts (14) von der Schiebernut (12c) nach außen öffnet, wobei sich der Arm (14b) über dem hinteren Teil über den Überhangteil (12e) des Nadelkörpers (12) hinaus erstreckt, und der Neigungsteil (14f) auf einer unteren Seite nach hinten über ein vorderes Ende des Arms (14b) hinaus ausgebildet ist.

3. Schiebernadel (21) für eine Flachstrickmaschine nach Anspruch 1, **dadurch gekennzeichnet, dass:**

ein vorderer Teil des Blatts (24) derart ausgebildet ist, dass die Zunge (24a) und ein Teil in Nachbarschaft zu dem hinteren Ende der Zunge (24a) in die Breite der Schiebernut (22c) fallen, an dem Nadelkörper (22) die Schiebernut (22c) ohne Bodenfläche (22d) nach hinten über den Überhangteil (22e) hinaus ausgebildet ist, und der Neigungsteil (24f) an einer oberen Seite nach vorne über das vordere Ende des Arms (24b) hinaus ausgebildet ist.

## Revendications

1. Aiguille composée (11, 21) pour une machine à tricoter à plat, comprenant :

un corps d'aiguille (12, 22) comportant un crochet (12a, 22a) au niveau d'une extrémité avant et une gorge de coulisseau (12c, 22c) formée sur une tige d'aiguille (12b, 22b) s'étendant vers l'arrière à partir du crochet (12a, 22a) ; et un coulisseau (13, 23) comportant deux lames

(14, 24), chaque lame (14, 24) étant munie d'une languette (14a, 24a) formée au niveau d'une portion avant, les lames (14, 24) étant capables de suspendre une maille et au moins une portion des lames (14, 24) étant mise dans la gorge de coulisseau (12c, 22c) du corps d'aiguille (12, 22) pour être guidée dans une direction avant-arrière, et les languettes (14, 24) ouvrant et fermant le crochet (12a, 22a) par un mouvement relatif vers le corps d'aiguille (12, 22), le corps d'aiguille (12, 22) étant muni de :

une portion de fermeture (12h, 22h), voisinant sur un côté arrière du crochet (12a, 22a) et ayant une surface inférieure (12d, 22d) dans une section de la gorge de coulisseau (12c, 22c) à mettre dans les languettes (14a, 24a) dans un état où la portion avant des languettes (14a, 24a) ferme le crochet (12a, 22a) ;

une portion d'effacement (12i, 22i), formée de façon à avoir une surface inférieure (12d, 22d) dans une portion de la gorge de coulisseau (12c, 22c) à mettre dans des portions d'extrémité de tête des languettes (14a, 24a),

**caractérisée en ce que** le corps d'aiguille (12, 22) est en outre muni d'une portion d'effacement (12i, 22i) formée de façon à ne pas comporter de surface inférieure (12d, 25d) dans une portion de la gorge de coulisseau (12c, 22c) à mettre dans les portions du côté arrière des languettes (14a, 24a) en arrière des portions d'extrémité de tête des languettes (14a, 24a) dans un état d'effacement où les languettes (14a, 24a) se déplacent vers l'arrière par rapport au corps d'aiguille (12, 22) sur un côté arrière de la portion de fermeture (12h, 22h) pour ouvrir le crochet (12a, 22a) et recevoir une maille reculant à partir du crochet (12a, 22a) ; et une portion en surplomb (12e, 22e), formée pardessus la portion d'effacement (12i, 22i) de façon à s'étendre à partir de l'arrière vers l'avant sur une largeur couvrant au moins la gorge de coulisseau (12c, 22c), et munie d'une portion de pression (12f, 22f) sur une surface de dessous, et

chacune des deux lames (14, 24) comportant :

un bras (14b, 24b), étendu sur l'arrière au-delà de la languette (14a, 24a) de façon à permettre un mouvement vertical de la languette (14a, 24a) par courbure élastique ; et une portion en pente (14f, 24f), prévue à proximité d'une portion d'extrémité avant du bras (14b, 24b) de façon à faire saillie vers

le haut à partir de la gorge de coulisseau (12c, 22c) dans une largeur, pour contacter avec la portion de pression (12f, 22f) la surface de dessous de la portion en surplomb (12e, 22e) du corps d'aiguille (12, 22), et pour réduire la hauteur entre l'avant et arrière.

2. Aiguille composée (11) pour une machine à tricoter à plat selon la revendication 1, **caractérisée en ce que**

la lame (14) a une portion de courbure (14e) au niveau de la portion avant, voisinant l'arrière de la languette (14a) et ouvrant une extrémité supérieure de la lame (14) vers l'extérieur de la gorge de coulisseau (12c),

le bras (14b) est étendu au-dessus de l'arrière au-delà de la portion en surplomb (12e) du corps d'aiguille (12), et

la portion en pente (14f) est formée sur un côté du bas vers l'arrière au-delà d'une extrémité avant du bras (14b).

3. Aiguille composée (21) d'une machine à tricoter à plat selon la revendication 1, **caractérisée en ce que**

une portion avant de la lame (24) est formée de telle sorte que la languette (24a) et une portion voisine vers l'arrière de la languette (24a) tombe dans la largeur de la gorge de coulisseau (22c),

sur le corps d'aiguille (22), la gorge de coulisseau (22c) est formée sans surface inférieure (22d) vers l'arrière au-delà de la portion en surplomb (22e), et la portion en pente (24f) est formée sur un côté du haut vers l'avant au-delà de l'extrémité avant du bras (24b).

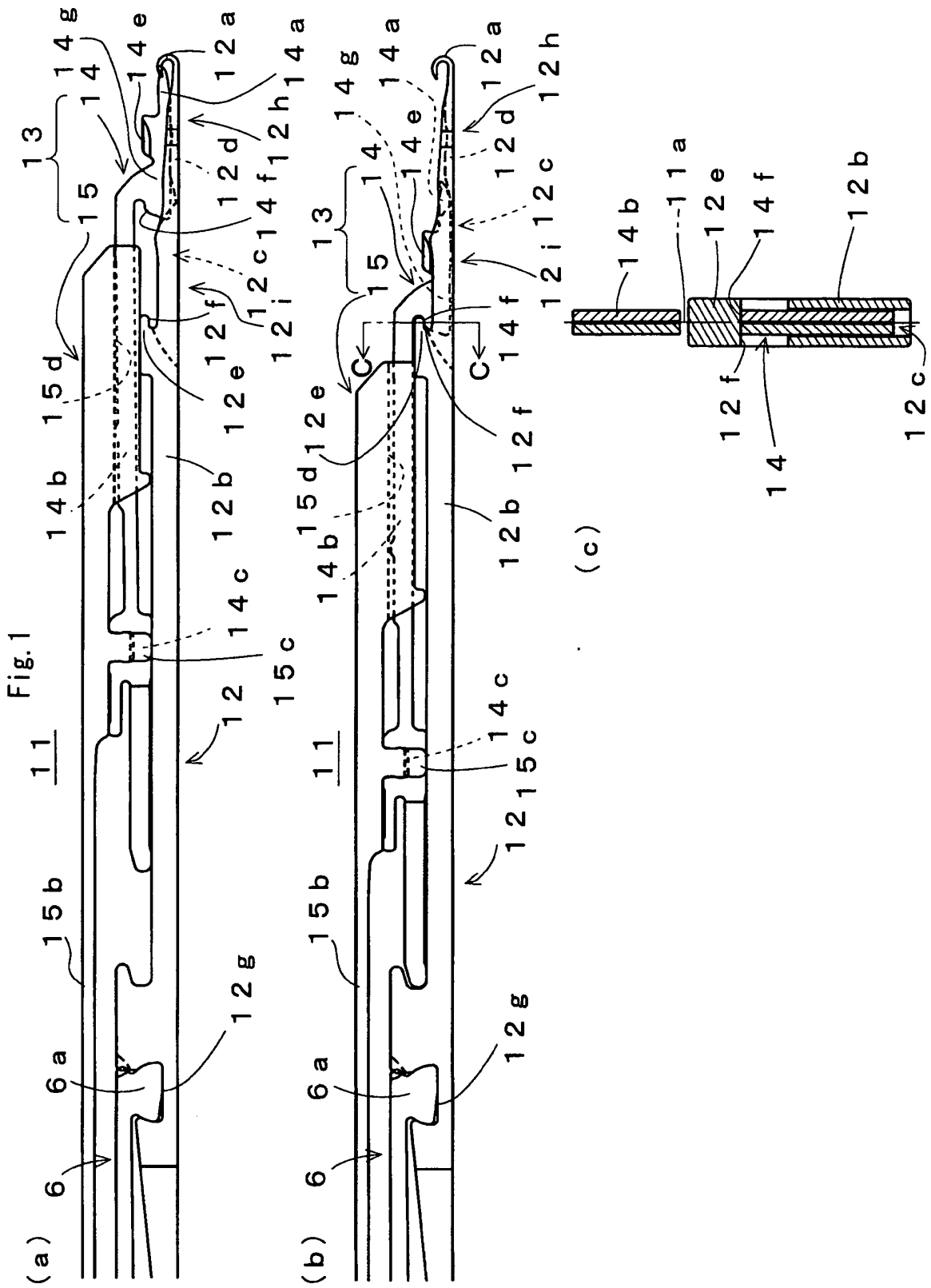

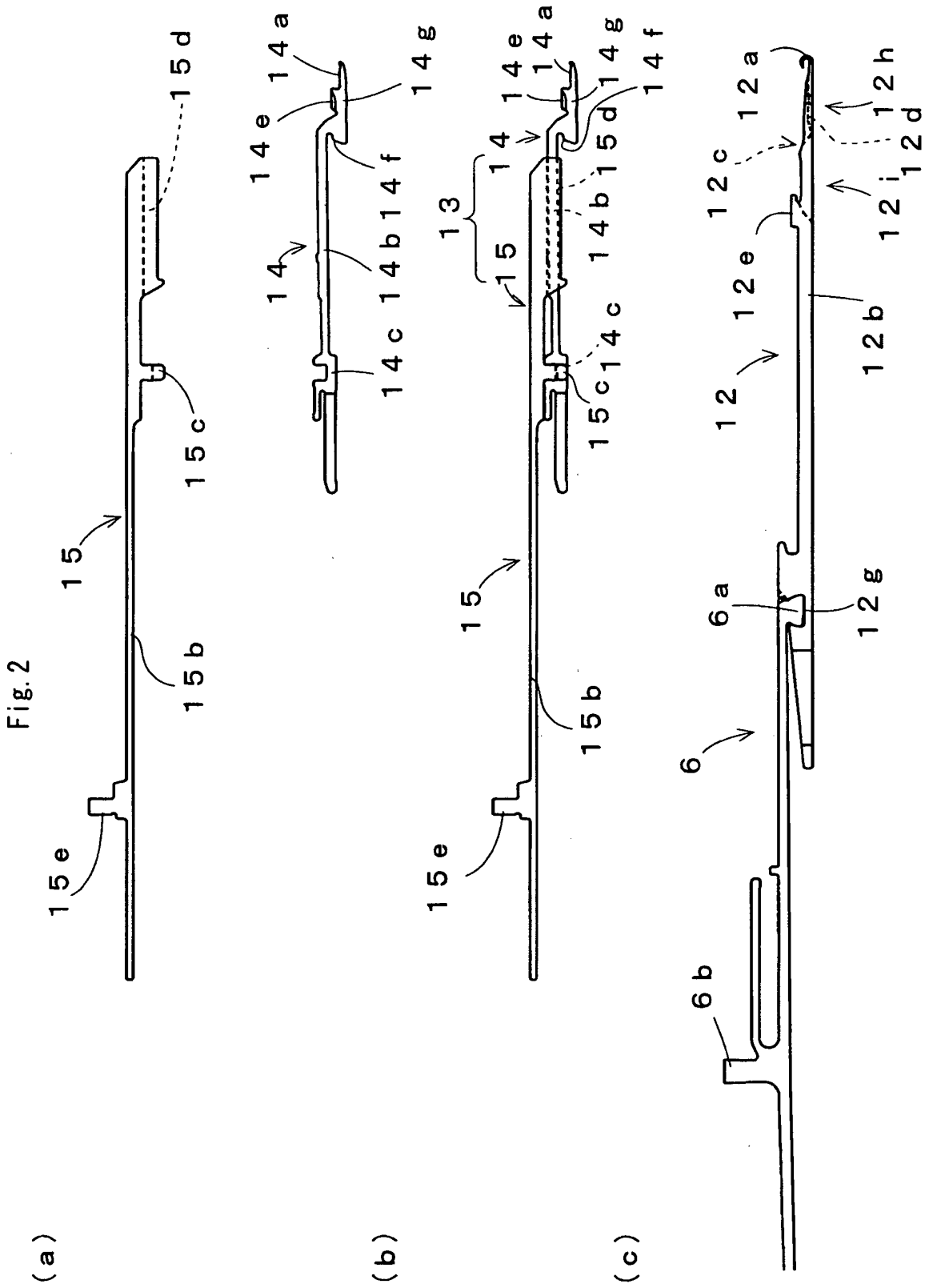

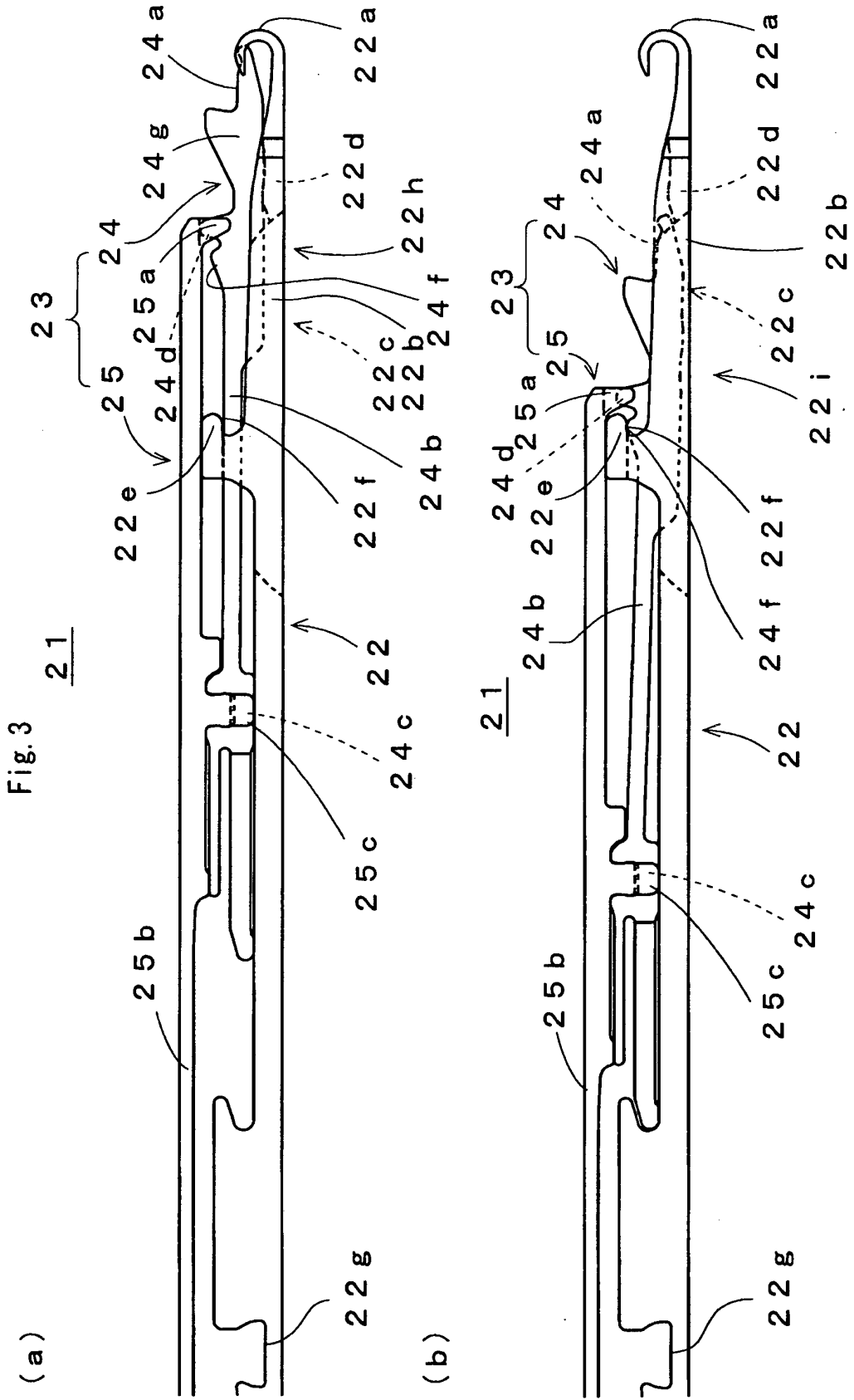

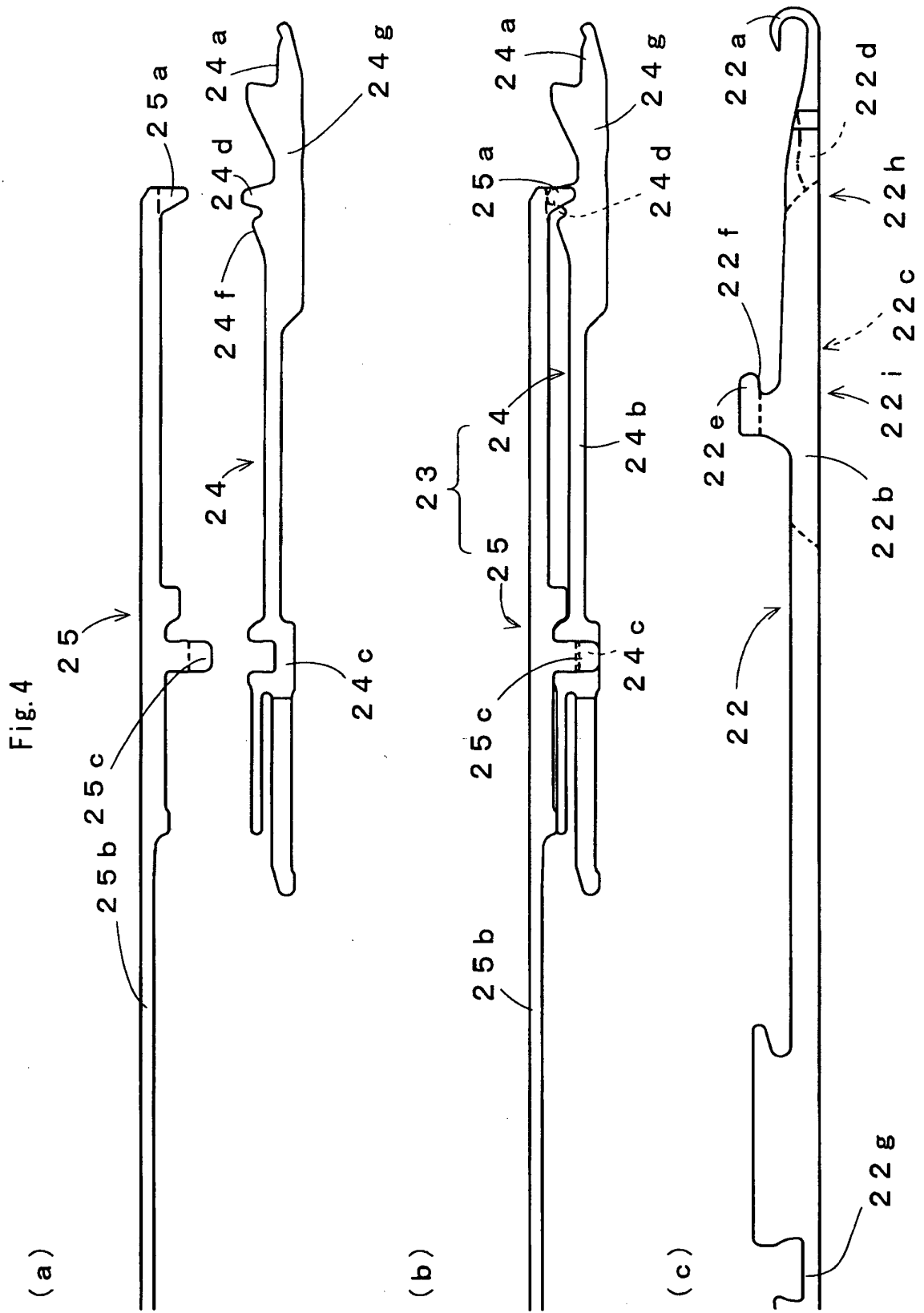

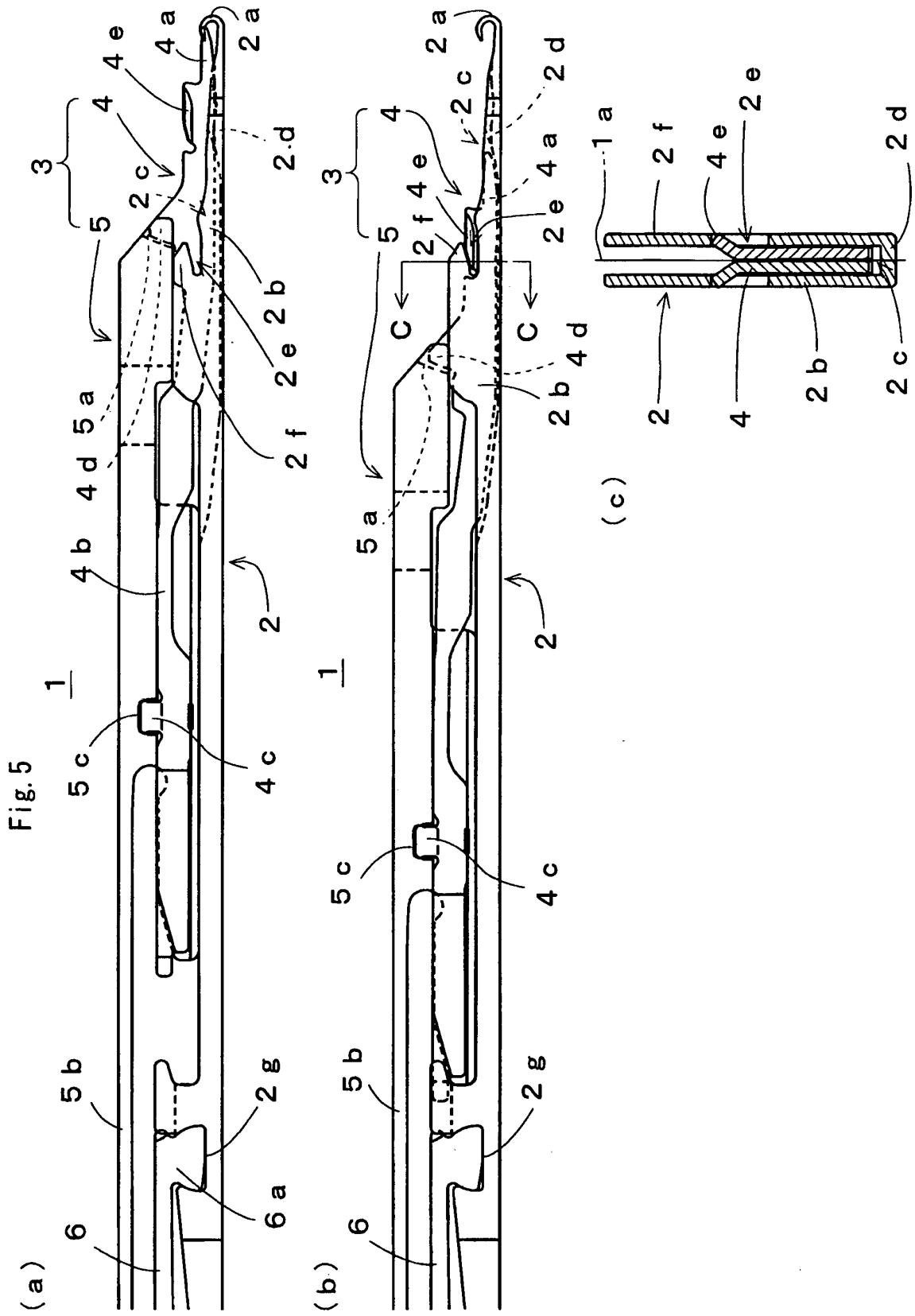

**REFERENCES CITED IN THE DESCRIPTION**

*This list of references cited by the applicant is for the reader's convenience only. It does not form part of the European patent document. Even though great care has been taken in compiling the references, errors or omissions cannot be excluded and the EPO disclaims all liability in this regard.*

**Patent documents cited in the description**

- JP 3577038 B [0008]
- EP 1229518 A [0008]