

(19)



(11)

**EP 2 462 271 B1**

(12)

**EUROPEAN PATENT SPECIFICATION**

(45) Date of publication and mention of the grant of the patent:  
**01.05.2013 Bulletin 2013/18**

(51) Int Cl.:  
**D06F 23/00** <sup>(2006.01)</sup> **D06F 23/06** <sup>(2006.01)</sup>  
**D06F 23/02** <sup>(2006.01)</sup> **D06F 23/04** <sup>(2006.01)</sup>

(21) Application number: **10748153.3**

(86) International application number:  
**PCT/IB2010/053573**

(22) Date of filing: **06.08.2010**

(87) International publication number:  
**WO 2011/016009 (10.02.2011 Gazette 2011/06)**

(54) **LAUNDRY WASHING MACHINE**

WASCHMASCHINE

MACHINE À LAVER LE LINGE

(84) Designated Contracting States:  
**AL AT BE BG CH CY CZ DE DK EE ES FI FR GB GR HR HU IE IS IT LI LT LU LV MC MK MT NL NO PL PT RO SE SI SK SM TR**

(72) Inventors:  
• **CALVI, Riccardo**  
**I-60044 Fabriano (Ancona) (IT)**  
• **BONGINI, Dino**  
**I-60044 Fabriano (Ancona) (IT)**

(30) Priority: **07.08.2009 IT TO20090628**

(74) Representative: **Gallarotti, Franco**  
**Via Maria Vittoria 18**  
**10123 Torino (IT)**

(43) Date of publication of application:  
**13.06.2012 Bulletin 2012/24**

(73) Proprietor: **Indesit Company, S.p.A.**  
**60044 Fabriano (AN) (IT)**

(56) References cited:  
**US-A- 537 603 US-A- 1 886 201**  
**US-A- 5 111 673 US-A- 5 442 937**  
**US-A- 6 012 306**

**EP 2 462 271 B1**

Note: Within nine months of the publication of the mention of the grant of the European patent in the European Patent Bulletin, any person may give notice to the European Patent Office of opposition to that patent, in accordance with the Implementing Regulations. Notice of opposition shall not be deemed to have been filed until the opposition fee has been paid. (Art. 99(1) European Patent Convention).

## Description

### Field of the invention

**[0001]** The present invention relates to a laundry-washing machine for domestic use, having a load-bearing structure that supports an oscillating assembly, the oscillating assembly including a washing tub and a laundry drum mounted in the tub for rotating about a respective working axis, the tub and the drum having respective access openings that are substantially coaxial or aligned with one another, in which the machine further comprises means for loading the tub with liquid, means for draining liquid from the tub, a motor for driving the drum, and a control system including command means, which can be switched by a user of the machine for controlling starting, or enabling execution of, a washing program.

### Background of the invention

**[0002]** Laundry-washing machines can be basically classified in two main types, here defined for reasons of simplicity as "machines of a European type" and "machines of a U.S. type".

**[0003]** In front-loading machines of a European type, the laundry drum is mounted in the washing tub so as to rotate about a substantially horizontal or slightly inclined axis, and the tub is housed within a cabinet. The cabinet has an opening for front loading, in front of which a hatch is mounted, and this opening is substantially aligned to a front opening of the tub, which is in turn substantially aligned to a front opening of the drum. The tub is elastically suspended within the cabinet to be able to perform oscillations determined by the loads acting on the drum during its rotation, said loads being due to the weight of the laundry being treated.

**[0004]** Top-loading European machines have a substantially similar structure, but with the difference that the tub has a top opening, facing a circumferential wall of the drum, provided on which is a corresponding hatch. The cabinet in turn comprises a respective top door, which enables access to the opening of the tub, and hence to the hatch of the drum. For the purposes of the operations of loading and unloading of the laundry, the drum is brought into an angular position such that the corresponding hatch is located at the top opening of the tub.

**[0005]** In U.S. machines, the tub is basically constituted by a cylindrical container open at the top, within which the laundry drum or an agitator is mounted so as to rotate according to a substantially vertical axis. Also the drum is open at the top, and the cabinet of the machine, within which the tub is housed, is provided with a top hatch.

**[0006]** Machines of a European type are particularly appreciated for the high quality of washing that can be obtained with relatively small volumes of water. In these machines, however, on account of the substantially horizontal arrangement of the axis of rotation of the drum

and of the force of gravity, there is the need to balance precisely the load of laundry in order to carry out some steps of the cycle, such as the centrifugation steps. This need, in addition to complicating to a certain extent organization of the operating programs (in order to detect and correct any possible unbalancing of the load), imposes structural arrangements and positioning of the counterweights for the oscillating assembly that complicate production of the machine.

**[0007]** Machines of a U.S. type enable washing results to be obtained that are qualitatively inferior as compared to those of European machines at least given the same amount of water used, but, also by virtue of the vertical arrangement of the axis of rotation of the drum, they feel to a limited extent any possible unbalancing of the load of laundry, and are thus structurally simpler and less expensive than machines of a European type. Machines of a U.S. type are moreover appreciated, as likewise are European machines of a top-loading type, on account of their high ergonomics of use and their flexibility of installation, due to the fact that loading/unloading of the laundry can be performed from the top of the cabinet.

**[0008]** Also known from the document US 5,327,603, on which the preamble of Claim 1 is based, is a laundry-washing machine of a "hybrid" type, i.e., one in which an oscillating assembly which includes the tub and the drum is mounted in a rotatable way so that it can be displaced about a substantially horizontal axis of inclination, between at least one upright position and a reclined position, in which the working axis of the drum is set in a substantially vertical direction or else in a substantially horizontal direction, respectively. The oscillating assembly is housed within a cabinet of the machine and, in conditions of normal operation, is displaced between the upright and reclined positions via purposely provided motor means, controlled by the control system of the machine. The oscillating assembly is accessible from above, when in the upright position, via a top hatch of the cabinet, and is in turn provided with a door of its own, having the purpose of preventing exit of the laundry from the assembly, in its two operating positions.

**[0009]** The machine known from US 5,327,603 is complicated to produce, cumbersome, and costly, and not effectively ergonomic for the user.

### Summary and object of the invention

**[0010]** In view of what has been set forth above, the object of the present invention is to provide a laundry-washing machine that is simple and inexpensive to produce and affords a level of operation that as a whole improved, also for the end user, as compared to the known art.

**[0011]** The above and other purposes, which will emerge more clearly hereinafter, are achieved according to the present invention by a laundry-washing machine and by a process for washing laundry having the characteristics specified in Claim 1 and Claim 13, respective-

ly. Preferred characteristics of the invention are specified in the sub-claims. The claims form an integral part of the technical teaching provided herein in relation to the invention.

#### Brief description of the drawings

**[0012]** The purposes, characteristics, and advantages of the present invention will emerge clearly from the ensuing description, with reference to the annexed drawings, which are provided purely by way of non-limiting example and in which:

- Figures 1 and 2 are two schematic views, respectively in front elevation and in side elevation, of a laundry-washing machine according to the invention, in a first condition;
- Figures 3 and 4 are two schematic views, respectively in front elevation and in side elevation, of a laundry-washing machine according to the invention, in a second condition;
- Figures 5 and 6 are two schematic views, respectively in front elevation and in side elevation, of a laundry-washing machine according to the invention in a third condition;
- Figure 7 is a schematic cross section of the machine according to the invention, in the condition of Figures 3 and 4;
- Figure 8 is a schematic view of the machine according to the invention, in a step of displacement;
- Figure 9 is a partially exploded schematic view of a portion of a machine according to an advantageous embodiment of the invention;
- Figure 10 is an enlarged detail of Figure 9;
- Figure 11 is a schematic view in front elevation of a machine according to the embodiment of Figure 9;
- Figure 12 is a schematic cross section according to the line XII-XII of Figure 11; and
- Figures 13 to 20 are schematic views, in side elevation, of the machine according to the invention, aimed at illustrating a possible use thereof.

#### Description of preferred embodiments of the invention

**[0013]** Reference to "an embodiment" or "one embodiment" in the context of this description indicates that a particular configuration, structure, or characteristic described in relation to the embodiment is comprised in at least one embodiment. Hence, phrases such as "in an embodiment" or "in one embodiment" and the like, that may be present in different parts of this description, do not necessarily all refer to one and the same embodiment. Furthermore, the particular configurations, structures, or characteristics can be combined in any adequate way in one or more embodiments. The references used herein are only for convenience and do not define the sphere of protection or the scope of the embodiments.

**[0014]** In the figures, designated as a whole by 1 is a

laundry-washing machine according to one embodiment of the present invention. The machine 1 comprises a load-bearing structure, designated as a whole by 2, which includes a base part 3 and two uprights or side members 4, substantially parallel to one another. The side members 4 are elastically mounted at opposite sides of the base part 3, with the interposition of damper means, designated by 5 in the side views, of any type suitable for the purpose, for example in the form of shock absorbers substantially of the leaf type. Defined in the bottom region of the base part 3 is a compartment 6 for housing a removable container 7, which can be used, for example, at the end of washing, for containing the laundry that is unloaded from the machine. The bottom face of the base part 3 is provided with feet 8 for standing on the floor; said bottom face of the base part has, in its front area, an inclined surface, at which wheels or rollers 9 are mounted.

**[0015]** Positioned between the side members 4 is an oscillating assembly, designated as a whole by 10, which is articulated in points diametrically opposite to the top regions of the side members 4. The coupling between the oscillating assembly 5 and the side members 4, obtained via articulation joints 11, is such that the oscillating assembly 10 can undergo displacement about a substantially horizontal axis of inclination designated by A.

**[0016]** In the embodiment exemplified, the structure 2 forms or substantially integrates also part of the cabinet of the machine, i.e., a part of casing directly in view; a further part of the machine 1 directly in view is formed by the oscillating assembly 10, which is accessible to a user in order to be manoeuvrable manually, as explained hereinafter.

**[0017]** The oscillating assembly 10 comprises a tub 12, generally cylindrical in shape, having a bottom and an access opening 12a at the end opposite to the bottom. As may be noted in particular in Figure 1, the opening 12a is surrounded by a gasket 12b, of annular shape. Housed within the tub 12 is a laundry drum, designated by 13 (Figures 1 and 7), which is can turn about a respective working axis, designated by B in Figures 2, 4 and 8. Also the drum 13 has a generally cylindrical shape, with a respective bottom facing the bottom of the tub 12 and an access opening 13a at the opposite end (Figure 7), substantially aligned to the opening 12a of the tub 12. The cylindrical wall of the drum 13 has arrays of holes (not represented) and is provided with lifter elements or lifters, two of which are designated by 13b in Figure 7. The tub 12 can be advantageously made totally or partially of moulded thermoplastic material; also the drum 13 can be made of moulded plastic material, or else at least in part of metal. In the example represented in Figure 7, externally associated to the top region of the drum 13 is at least one counterweight element, having a generally annular or semi-annular shape, designated by 13c. At least one counterweight element could be associated, in addition or as an alternative to the one designated by 13c, to the body of the tub 12.

**[0018]** The oscillating assembly 10 further comprises a door 14, which is articulated to the casing of the assembly itself; in the example, the tub body defines for said purpose two parallel lugs 15, between which the door 14 is hinged in the points designated by 15a. The door preferably comprises a frame 14a and a containment body 14b, which is preferably transparent, for example made of glass. Preferably, as may be seen in Figure 7, the containment body 14b is shaped so as to project towards the inside of the tub 12, until it penetrates into the access mouth of the drum 13, i.e., its front part, which delimits the opening 13a. As may be seen, the machine 1 has a single door, namely, the one designated by 14, which is directly accessible from outside the structure 2.

**[0019]** The machine 1 comprises all the components traditionally necessary for its normal operation, which include at least means for loading and draining liquid, means for heating the liquid, motor means to set the drum in rotation, safety means, and a control system.

**[0020]** The aforesaid means for loading the tub with liquid (which are represented only in part) comprise a loading duct, which gives out into the tub and the inlet of which is connected to a pipe for connection to a domestic water supply, as well as a loading solenoid valve, controlled by the control system of the machine, according to a technique in itself known. The loading means also comprise a sensor for detecting the level of the liquid charged into the tub, such as for example a pressure switch. The aforesaid pipe and solenoid valve are represented only in Figure 2, where they are designated by IN and EV, respectively.

**[0021]** The aforesaid means for heating the liquid (not represented) comprise an electrical resistor, positioned within the tub 12 in the proximity of the bottom thereof, the supply of said resistor being controlled by the control system of the machine, which comprises for the purpose a temperature sensor or thermostat.

**[0022]** The aforesaid means for draining the water from the tub, which are represented only in part, comprise a drain pump, the suction section of which is connected to an opening present on the tub bottom and the delivery section of which is connected to a drain duct, which is in turn connected to a pipe for connection to a discharge union belonging to the domestic sewage system. The drain pipe is represented only in Figure 2, where it is designated by OUT. Also represented in said figure is the electrical supply cable of the machine 1, designated by EL.

**[0023]** The aforesaid motor means comprise an electric motor, controlled by the control system to set the drum 13 in rotation, in the appropriate times and with the appropriate modalities (speed, periods of rotation, periods of pause, possible reversals of rotation, etc.), according to techniques in themselves known. In the example represented (see Figure 7), the machine has a system for driving the drum of the type generally known as "direct drive", i.e., one with a motor 16, the stator of which is fixed directly on the outside of the tub bottom, in a central

position, and with the rotor directly associated to the shaft for driving the drum 13. Of course, this type of drive is not to be understood as limiting; as an alternative, a traditional electric motor can be provided, connected via a suitable transmission (for example, a belt and pulley system) to the shaft of the drum 13.

**[0024]** The aforesaid safety means (not represented) comprise a door-lock device, having a structure in itself known, controlled by the control system of the machine. As per the known art, said device can be switched between an operative condition and an inoperative condition, in which opening of the door 14 is prevented and allowed, respectively.

**[0025]** The aforesaid control system preferably comprises a microcontroller control logic, with associated memory means, encoded in which are the instructions for general operation of the machine and one or more corresponding operating programs. The control system comprises a control panel or user interface, designated by 17 in the figures, having keys or push-buttons through which a user can select the washing program and the possible options that can be associated thereto (type of laundry, "no spin", "half load", etc.). The control system includes command means (described hereinafter), which can be switched by the user for controlling starting, or enabling execution of, an operating program.

**[0026]** As may be appreciated from the comparison between Figure 2 and Figure 4, in the machine 1 according to the invention, the oscillating assembly 10 is rotatably supported by the load-bearing structure 2 in such a way that it can be displaced about the axis A, between at least one upright position, in which the working axis B of the drum 13 is set in a substantially vertical direction, and at least one reclined position, in which the axis B is set in a substantially horizontal direction.

**[0027]** It should be noted that, in the present description, the terms "set in a substantially vertical direction" and "set in a substantially horizontal direction" referring to the working axis B are intended to designate positions of the axis itself that are at least approximately vertical or horizontal. In particular, in the preferred embodiment, in the at least one upright position, the axis B of the drum 13 forms an angle  $\alpha$  of between approximately 75° and 90° with respect to a horizontal plane (see Figure 2), whilst in the at least one reclined position, the angle  $\alpha$  is between approximately 0° and 15°, preferably approximately 5°-10° (see Figure 4). Furthermore, as will emerge more clearly hereinafter, in the preferred embodiment the oscillating assembly 10 may assume and maintain stably two different upright positions, in which the inclination of the working axis B of the drum with respect to the aforesaid horizontal plane is different. In particular, in the upright position represented in Figure 2, the angle  $\alpha$  (preferably approximately 75°-85°) is smaller than the one reached in the upright position, as represented in Figure 6 (preferably approximately 90°).

**[0028]** In order to keep the oscillating assembly 10 stably in the reclined position of Figures 3 and 4, the machine

is provided with retaining means, which can be electrically controlled by the control system of the machine. In one embodiment, these retaining means (not represented) can be obtained using the technology typical of door-lock devices for electrical household appliances. In said embodiment, for example, provided on the outside of the assembly 10 is an engagement element, which, when the assembly itself is in the reclined position, is engaged and withheld by a retention member, actuated by an electric actuator. Another technique that can be used for providing the aforesaid retaining means is that of drum-blocking devices, used in certain top-loaded washing machines for blocking rotation of the drum at the end of the washing cycle. The retaining means designed to prevent angular movement of the oscillating assembly 10 when this is in the reclined position can be integrated in at least one of the articulations 11, for example as in an embodiment described hereinafter with reference to Figures 9-12.

**[0029]** As mentioned previously, the control system of the machine is provided with command means, which can be switched by the user for controlling starting, or enabling execution of, a treatment program. According to one aspect of the invention, said command means are prearranged in such a way that the corresponding switching is obtained following upon a manual displacement of the oscillating assembly 10 from the at least one upright position to the at least one reclined position, and more precisely from the position of Figures 1-2 (obviously with the door 14 closed) to the position of Figures 3 and 4.

**[0030]** These switching means can be constituted, for example, by a simple electrical switch or push-button, which is switched by the assembly 10, when it reaches the position of Figures 3-4. Said switching of the switch enables electrical supply of the machine, and hence of its internal electrical components. In one embodiment, the aforesaid switching determines closing of an electrical switch that can be controlled by the control system, such as for example a relay, in such a way that the circuit for supply of the machine 1 is kept in a closed condition even when - as will be seen hereinafter - , in the course of a washing program, the assembly 10 displaces autonomously towards an upright position. A different embodiment of the aforesaid command means will be described hereinafter with reference to Figures 9-12.

**[0031]** Amongst the electrical components that are supplied once the reclined position has been reached there is the door-lock device, purposely controlled by the control system. The safety means of the machine are arranged in such a way that the door-lock device is brought to assume its operative condition, of locking of the door 14, once the reclined position is reached, and said operative condition is practically maintained up to the end of the washing program and/or until the electrical components carried by the oscillating assembly 10 can be supplied electrically. Consequently, as may be appreciated, the door 14 can be opened when the assembly 10 is located in an angular position comprised between

the upright one and the reclined one, prior to start of a washing program (i.e., until the assembly is brought manually from the position of Figures 1-2 to the position of Figures 3-4).

5 **[0032]** The machine 1 according to the invention is provided with driving means, for displacing in an automated way, in the course of execution of an operating program, the oscillating assembly 10 from the reclined position to an upright position, namely the position illustrated in Figures 5-6, where the axis B is substantially vertical.

10 **[0033]** In a preferred embodiment, the aforesaid driving means comprise at least one accumulator of mechanical energy, for example a spring, which is loaded following upon manual displacement of the oscillating assembly 10 from the position of Figures 1-2 to the position of Figures 3-4. As previously explained, when the assembly 10 is brought into the reclined position, it is kept in said position by the retaining means: also the accumulator of mechanical energy is thus kept in the respective loaded condition. In the course of execution of a washing program, the control system then sends a command for release of the retaining means, with the result that also the accumulator of mechanical energy is released in such a way that its elastic reaction causes a movement of the oscillating assembly 10 from the reclined position to the upright position of Figures 5-6. Such an accumulator of energy can for example be positioned in the area of each articulation 11, as in an embodiment described hereinafter with reference to Figures 9-12. Preferably, moreover, the aforesaid driving means comprise clutch means, which can be obtained with any technique in itself known, in order to slow down the movement induced in the assembly 10 by release of the spring or springs used.

20 **[0034]** The embodiment provided with means for accumulating mechanical energy is particularly simple and inexpensive to produce. It will be appreciated, however, that in more sophisticated embodiments the movement of the assembly 10 between the reclined and upright positions can be obtained via appropriate electric actuator means, such as for example a rotary motor.

30 **[0035]** Preferably, the machine 1 is also provided with retaining means operative for keeping the oscillating assembly 10 stably in the upright position of Figures 5 and 6. These retaining means can be electrically controlled by the control system of the machine and be conceived in a way similar to the ones used for keeping the assembly 10 in the reclined position. Possibly, retaining means of the same sort may be provided to keep the assembly both in the reclined position and in the upright position, as in an embodiment described hereinafter with reference to Figures 9-12. The retaining means for keeping the assembly 10 in the upright position of Figures 5 and 6 can also comprise a blocking device of a mechanical type, which can be switched manually via a release and reset element. In this case, when said upright position is reached by the assembly 10, the device is switched by the movement of the assembly itself (like a door lock of a motor vehicle), for example by clicking into position, to

block the assembly in the position reached. Subsequently, when it is necessary to bring the assembly from the position of Figures 5-6 to the position of Figures 1-2, the user of the machine intervenes on the command element, for example a mechanical key or a handle, which causes release of the device and resetting thereof.

**[0036]** In general terms, a washing program that can be run on the machine 1 includes at least one washing step, in the course of which the drum 13 is rotated in the presence of washing liquid in the tub 12, at least one rinsing step, in the course of which the drum 13 is rotated in the presence of rinsing liquid in the tub 12, and at least one centrifugation step, in the course of which the drum 13 is rotated at a relatively high speed, in the substantial absence of liquid in the tub 12.

**[0037]** In one embodiment, the control system is configured for controlling execution of the washing step when the oscillating assembly 10 is in a reclined position, and specifically the position of Figures 3-4, and for controlling execution of at least one between the rinsing step and the centrifugation step, and preferably both the rinsing step and the centrifugation step, when the oscillating assembly 10 is in an upright position, and specifically the position of Figures 5-6.

**[0038]** Figures 9-12 illustrate a possible embodiment of retaining means designed to maintain the oscillating assembly 10 in the reclined and upright positions, a possible embodiment of the command means, and a possible embodiment of the driving means.

**[0039]** With particular reference to Figures 9-10, in said embodiment, the structure of the oscillating assembly 10 has two opposite articulation pins, only one of which is visible, designated by 20 in Figure 10. The pin 20, here generally tubular, is for example designed to be coupled to a bearing (not visible), housed in a seat provided in the corresponding upright 4.

**[0040]** The pin 20 is surrounded by a ring or rim 21, in the outer surface of which recesses 22, 23 and 24 are made in predefined angular positions, each recess corresponding to a stable position that can be assumed by the oscillating assembly 10, as described hereinafter. The pin 20 and the ring 21 are in fixed relative positions and can be made integrally with the structure of the oscillating assembly, for example with the tub body.

**[0041]** Designated by 25 is a blocking device, which can be electrically controlled and forms the aforesaid retaining means and is fixed to the structure of the upright 4. The device 25 comprises an arrest element 25a, loaded by a spring (not shown) in a extracted or blocking position. In particular, the device 25 is positioned in such a way that the aforesaid spring pushes a head of the arrest element 25a towards the outer annular surface of the ring 21. The head of the element 25a is conveniently shaped to engage each time in the recesses 22-24, according to the angular position of the assembly 10. The device 25 further comprises electrically controlled actuator means (not visible), designed to produce recession and to block the element 25a selectively in position; said

actuator means can comprise, for example, a solenoid or an electric thermal-actuator.

**[0042]** Designated by 26 is a torsion spring, which forms the accumulator of mechanical energy referred to previously. In the example, the spring 26 is positioned in an annular region or seat 27 comprised between the pin 20 and the ring 21. The ends of the spring 26 are engaged one with the oscillating assembly 10 and the other with the structure of the upright 4 in such a way that, when the assembly 10 is brought from the position of Figures 1-2 to the position of Figures 3-4, the spring 26 is loaded.

**[0043]** In the example of Figures 9-10, and as may be seen also in Figure 12, the aforesaid command means comprise a movable contact, designated by 28, carried by the assembly 10, and specifically fixed at the outer surface of the ring 21, and a pair of fixed contacts 29a and 29b, which in the example are defined by an element 29, having an electrically conductive body, substantially shaped like the arc of a circumference and fixed on the structure of the upright 4, in a position facing the outer surface of the ring 21. The fixed contacts 29a and 29b are designed to cooperate with the movable contact 28, as will be explained hereinafter, only when the assembly 10 is in the positions of Figures 3-4 and Figures 5-6, respectively. From Figure 12 it may be noted how the switch means constituted by the contacts 28 and 29a-29b are connected in series on the supply line for electrical components mounted on the oscillating assembly 10, designated as a whole by 30 and comprising at least the motor 16, the door-lock device, and possibly the drain pump. In said Figure, the symbols "+" and "-" indicate, respectively, the live and the neutral of a supply voltage.

**[0044]** A typical example of use and operation of the machine 1 is described hereinafter, with reference to Figures 13-20.

**[0045]** In Figure 13, the machine is represented with the oscillating assembly 10 in its typical position that precedes start of an operating program, with the door 14 open (condition similar to those of Figures 1-2). As has been seen, in said position, the axis of the drum is slightly inclined with respect to the vertical, and this favours, from the ergonomic standpoint, the operations of loading (and unloading, at the end of cycle) of the laundry. The user can hence load the laundry into the drum and, when the desired loading is complete, re-close the door 14, as represented in Figure 14. In the simplest embodiment, the machine 1 is not provided with a dispenser of washing agents, so that the user introduces the detergent directly into the drum 13 with the door 14 open. In more sophisticated solutions, the machine 1 can in any case be provided with a dispenser designed to deliver the washing detergents and the possible rinsing additive in the appropriate points of the cycle, according to techniques in themselves known.

**[0046]** In the case of the embodiment of Figures 9-12, in the position of Figure 14, the electrical components 30 of the oscillating assembly 10 (the motor 16, the door-lock device and preferably the drain pump), cannot receive

supply voltage in so far as the movable contact 28 is not electrically in contact either with the fixed contact 29a or with the fixed contact 29b (Figure 12). In said position, moreover, the arrest element 25a is engaged in the recess 22 thanks to the action of the corresponding spring.

**[0047]** It is to be noted that, when an operating cycle is not in progress, the drum of the machine 1 can be advantageously exploited as container for accumulation of the laundry to be washed.

**[0048]** The user can then set the washing program via the user interface 17. In a simplified embodiment, the commands provided on the user interface comprise keys substantially of a push-push type, i.e., of the type in which closing of the corresponding electrical contacts is maintained mechanically until a new pressure is applied on the same key or on another key. A solution of this sort enables selection of the washing program, and the possible associated options, even if still electric power has not been yet supplied to the entire machine 1, as in one embodiment (not represented) in which the passage of the oscillating assembly 10 from the position of Figures 1-2 to the position of Figures 3-4 enables supply to the entire machine.

**[0049]** In another embodiment, for example - but not necessarily - that of Figures 9-12, the electrical circuit of the machine 1 is prearranged in such a way that the control system is supplied, following upon switching of an ON/OFF switch operable on the interface 17 in such a way that selection of the program, and of the various associated options, as well as starting thereof, can be performed by the user even after displacement of the oscillating assembly 10 into the reclined position, in which also supply of the electrical parts of the assembly 10 is enabled.

**[0050]** The user turns the oscillating assembly 10 manually, as may be seen in Figure 15, where rotation occurs in a clockwise direction, as far as into the reclined position, as may be seen in Figure 16 (condition similar to those of Figures 3-4). The assembly 10, preferably the door 14, is purposely provided with a handle, designated by 10a only in Figures 3, 5 and 7 to facilitate said operation. The movement exerted manually on the assembly 10 brings about disengagement of the arrest element 25a of the blocking device 25 (which in this step is not supplied) from the recess 22, by overcoming the reaction of the corresponding spring. After disengagement, said spring in any case brings about a pressure of the element 25 on the outer surface of the ring 21 (Figure 12; it is to be noted that the reference directions of Figure 12, on one side, and of Figures 13-20, on the other side, are different, so a movement in a clockwise direction in any one of Figures 13-20 corresponds to a counterclockwise movement in Figure 12). Furthermore, in the course of displacement of the assembly 10 the spring or springs 26 that provide the accumulator means with mechanical energy are loaded, as explained previously.

**[0051]** When the position of Figure 16 is reached, which may possibly be determined by a mechanical

end-of-travel device, the movable contact 28 (Figure 12) comes into contact with the fixed contact 29a, and the arrest element 25a of the blocking device 25 is engaged in the recess 23 (Figure 12) under the action of the corresponding spring.

**[0052]** When the position of Figure 16 is reached, it has the effect of enabling electrical supply to the components 30 of Figure 12, and closing of the contact 28-29a informs the control system that the device 25 can now receive an electrical command: consequently, the arrest element 25a, engaged in the recess 23, is blocked in position, thus blocking the assembly 10 in the reclined position. The control system can now control electrical supply to the door-lock device, which passes into the respective condition for locking the door 14. Also the electric motor 16 can now receive the supply voltage and is ready to be started by the control system.

**[0053]** The control system controls start of the washing program previously set via the interface 17. Following upon starting of the program, the control system controls charging of the tub with water from the water supply, heating thereof, and agitation of the drum by controlling the motor 16.

**[0054]** The drain pump of the machine can be set at the tub bottom such as to enable practically complete discharge of the liquid even with the drum in the reclined position, and this arrangement is useful whenever a treatment program envisages carrying out a number of distinct washing steps (for example, a pre-washing step and a washing step), each of which includes an initial charging and a final discharging of liquid. Complete discharge of the washing liquid from the tub can in any case be obtained even subsequently, when the assembly 10 is brought into the upright position and prior to start-up of a rinsing step.

**[0055]** At the end of the washing step (or of the last washing step envisaged), the control system control the device 25 in such a way as to cause a recession of the arrest element 25a. The head of the element 25a disengages from the recess 23 (Figure 12). In this way, the assembly 10 is released and, under the action of the spring 26 (Figures 10 and 12), is automatically displaced towards the upright position, as may be seen in Figure 17, with a rotation opposite to the previous one, and hence counterclockwise.

**[0056]** Attainment of the upright (visible in Figure 18, which is a condition similar to that of Figures 5-6) can be determined by a mechanical end-of-travel device, for example of a click releasable type. When said position is reached (which the control system recognizes thanks to closing of the contact 28-29b), the control system controls the device 25 so as to terminate recession of the element 25a: under the action of the corresponding spring, the element 25a can hence engage in the recess 24 of the ring 21. The control system then controls blocking in position of the element 25a, and hence of the assembly 10, in the upright position. In said condition, moreover, the electrical parts of the assembly 10 may again

be supplied.

**[0057]** In the course of automatic displacement of the assembly 10 between the reclined position and the raised position, the electrical parts of the assembly 10, amongst which the door-lock device, are not electrically supplied. In any case, according to techniques in themselves known and as envisaged by relevant standards, the door-lock device includes means (for example, a bi-metal element, or a thermal-actuator) designed to keep the device itself in a condition of blocking of the door 14 for a certain safety period after interruption of the corresponding electrical supply. Said safety period has a duration longer than the one required by the assembly 10 for automatic displacement from the reclined position to the raised one, without hence causing a reduction of the characteristics of operative safety. As already mentioned, moreover, clutch means can be applied to the machine 1, which are designed to reduce the angular velocity of rotation of the assembly 10 down to a safety speed.

**[0058]** When the assembly 10 is in the vertical position (Figure 18), the control system controls the drain pump to evacuated the washing liquid present in tub (if said draining has not been performed completely previously). The control system then controls charging of the water necessary for executing the rinsing step, with a new controlled movement of the drum by the motor 16.

**[0059]** At the end of the rinsing step, or of each rinsing step, the liquid is evacuated from the tub, via actuation of the drain pump. Next, the control system issues a command for the centrifugation step or steps. In the course of each centrifugation step the drain pump can be supplied in a pulsed mode in order to expel the liquid that is released by the laundry.

**[0060]** Once centrifugation has ended, the control system removes supply from the device 25. The user can then displace the oscillating assembly 10 manually towards the initial position, as illustrated in Figure 19. The movement exerted manually by the user upon the assembly 10 is such as to enable disengagement of the arrest element 25a of the blocking device 25 from the recess 24 (as well as release of the possible mechanical end-of-travel device referred to previously). Also in this case, after said disengagement and at a certain point of rotation of the assembly 10, the element 25a comes to engage with the recess 22 of the ring 21, in the starting position. This displacement moreover results in the movable contact 28 no longer being in contact either with the fixed contact 29b or with the fixed contact 29a: the electrical components of the assembly 10, including the door-lock device, can no longer receive electrical supply. After the safety period mentioned previously, then, the user can open the door 14 and unload the laundry from the drum 13; for this purpose, the container 7 for accumulation of the washed laundry can be exploited, as may be seen in Figure 20.

**[0061]** Previously, reference was made to an embodiment, alternative to those of Figures 9-12, in which the command means comprise an electrical switch or

push-button, switching of which is caused by the manual displacement of the assembly 10 from the upright position to the reclined position in order to bring about closing of a relay. In said embodiment, at the end of the washing cycle, it is the control system that brings about opening of the relay, in such a way that the electrical supply to the machine 1 is interrupted. Hence, also in this case the supply to the door-lock device ceases, and thus the door 14 can be opened by the user for unloading the laundry.

**[0062]** As explained previously, the machine is provided with wheels or rollers 8 at an inclined surface defined on the bottom of the structure 2, in the corresponding front area. This arrangement enables, if need be, convenient displacement of the machine 1 simply by tilting it slightly forwards, as shown in Figure 8.

**[0063]** The machine according to the present invention enables combination of the advantageous characteristics proper to machines with vertical axis (lightness, ergonomics of use, centrifugations that substantially do not feel any unbalancing of the load), with the advantageous characteristics proper to the machines with horizontal axis (effective washing with reduced amounts of water). The overall structure of the machine is relatively simple, far from cumbersome, and lighter than known machines, given the same laundry loading capacity. The fact that start of an operating program and/or electrical supply of the entire machine or its components associated to the oscillating assembly and/or locking of the door is enabled by the manual displacement of the assembly itself into a given position enables simplification of the user interface of the machine, its safety characteristics, and the modalities of use by the user. Direct accessibility to the assembly 10 from outside the structure 2, in addition to simplifying the operations of loading and unloading of the laundry, enables provision of the machine with a single door and a single door-lock device, as well as facilitation of visual control of loading of laundry, through the transparent part of said single door.

**[0064]** Of course, without prejudice to the principle of the invention, the details of construction and the embodiments may vary widely with respect to what is described and illustrated herein purely by way of example, without thereby departing from the scope of the present invention as defined in the annexed claims.

**[0065]** In a preferred embodiment, the drain pump carried directly by the oscillating assembly 10 is mounted at the tub bottom, which is preferably made of moulded plastic material, in which the seat for the impeller of the pump is advantageously defined; from said seat there branch off the corresponding suction and delivery branches. Once again preferably, in the plastic body of the tub there can be formed part of the drain duct, which rises along the body of the tub up to one of the regions 11 of articulation to the load-bearing structure 2.

**[0066]** Advantageously, and irrespective of the type of installation of the drain pump, at least one stretch of the drain duct can extend in an area corresponding to an articulation 11, substantially coaxial to the axis A, said

stretch of duct possibly being integrated with, or forming, the articulation pin or a hub thereof. In the same way, also the duct for loading liquid into the tub can have a respective stretch, substantially coaxial to the axis A, passing through an articulation, for example the articulation 11 opposite to the one in which a stretch of the drain duct passes.

**[0067]** In a particularly advantageous embodiment, the aforesaid stretches of the drain duct and of the loading duct pass through one and the same articulation and are made substantially coaxial or concentric to one another, in particular formed in one and the same member that functions as hub or supports the articulation pin. In this case, one of the stretches of duct gives out directly into the tub, for charging liquid, and the other is connected to the delivery of the drain pump, for evacuation of the liquid from the tub. In this perspective, in one possible embodiment, the hydraulic passages are concentrated at one of the side members 4, whilst in the other side member electrical parts pertaining to the movement of the assembly 10 are concentrated, such as the possible electrically actuated retaining means, the command means for starting the cycle and/or enabling electrical supply to the machine or to the assembly 10, the possible sensors/electrical contacts used for detecting that the positions that can be assumed by the assembly 10 have been reached, and possibly the interface 17, as in the examples illustrated.

**[0068]** In the embodiment exemplified in the figures, the oscillating assembly 10 may assume two different upright positions, one of which (Figures 1-2) slightly inclined with respect to the vertical in order to facilitate, from the ergonomic standpoint, the operations of loading and unloading of the laundry. It will be appreciated, however, that, in alternative embodiments, the machine 1 can be prearranged in such a way that the assembly 10 can assume just one upright position, preferably corresponding to that of Figures 5-6, with the axis B substantially vertical, both for carrying out the steps of rinsing and/or the steps of centrifugation and for carrying out the operations of loading and unloading of the laundry.

## Claims

1. A laundry-washing machine for household use, having a structure (2) supporting an oscillating assembly (10), the oscillating assembly including a washing tub (12) and a laundry drum (13) mounted in the tub (12) for rotating about a respective working axis (B), the tub (12) and the drum (13) having respective access openings (12a, 13a) that are substantially coaxial or aligned to each other, the machine (1) also comprising means (EV, IN) for loading the tub (12) with liquid, means (OUT) for draining liquid from the tub (12), a motor (16) for driving the drum (13), a control system (17) including command means (28,29) switchable by a user of the machine (1) for

controlling starting, or enabling execution of, a washing program,

wherein the oscillating assembly (10) also includes a door (14) for opening and closing at least the access opening (12a) of the tub (12),

wherein the oscillating assembly (10) is supported by the structure (2) in a rotatable manner, to be displaceable about a substantially horizontal inclination axis (A) between at least one upright position, in which the working axis (B) of the drum (13) is set in a substantially vertical direction, and at least one reclined position, in which the working axis (B) of the drum (13) is set in a substantially horizontal direction, **characterized in that** the structure (2) and the oscillating assembly (10) are configured such that the oscillating assembly (10) is manually displaceable from the at least one upright position to the at least one reclined position, and **in that** the command means (28, 29) are prearranged to be switched by means of a manual displacement of the oscillating assembly (10) from the at least one upright position to the at least one reclined position.

2. The machine according to Claim 1, wherein the command means (28, 29) are prearranged for enabling an electric supply to the machine (1) and/or to electrical components (16, 30) mounted on the oscillating assembly (10) following upon manual displacement of the oscillating assembly (10) into the at least one reclined position.
3. The machine according to Claim 1 or Claim 2, also comprising safety means, including a door-lock device, which is carried by the oscillating assembly (10) and switchable between an operative condition and an inoperative condition, in which opening of the door (14) is prevented or allowed, respectively, the safety means being prearranged such that the door-lock device assumes the aforesaid operative condition when the oscillating assembly (10) is displaced into at least one substantially predetermined angular position with respect to said substantially horizontal inclination axis (A), in particular into said at least one reclined position.
4. The machine according to any of Claims 1-3, wherein
  - in the at least one upright position, the driving axis (B) of the drum (13) has an inclination comprised between 75° and 90° with respect to a horizontal plane; and
  - in the at least one reclined position, the driving axis (B) of the drum (13) has an inclination comprised between 0° and 15° with respect to a horizontal plane.
5. The machine according to Claim 1 or Claim 4, wherein the at least one upright position comprises a first

- upright position and a second upright position, in the first upright position the inclination of the working axis (B) of the drum (13) with respect to a horizontal plane being greater than in the second upright position.
- 5
6. The machine according to Claims 3 and 5, wherein said at least one substantially predetermined angular position comprises the above said first upright position.
- 10
7. The machine according to Claim 1, further comprising driving means (26), for displacing in an automated manner the oscillating assembly (10) from the at least one reclined position to the at least one upright position.
- 15
8. The machine according to Claim 1, further comprising switchable retaining means (25), for keeping the oscillating assembly (10) in at least one of said at least one reclined position and said at least one upright position.
- 20
9. The machine according to Claims 7 and 8, wherein the driving means comprise at least one accumulator of mechanical energy (26), such as a spring, which is loaded following upon the above said manual displacement of the oscillating assembly (10) from the at least one upright position to the at least one reclined position, the at least one accumulator of mechanical energy (26) being released following upon a switching of the retaining means (25) controlled by the control system, to cause a movement of the oscillating assembly (10) from the at least one reclined position to the at least one upright position.
- 25
- 30
- 35
10. The machine according to any of the preceding claims, wherein
- 40
- at least one of the means for loading and the means for draining includes a duct having a respective section at an articulation (11) between the oscillating assembly (10) and the structure (2), and/or
  - the oscillating assembly (10) supports at least one of the electric motor (16) for driving the drum (13), an electrical door-lock device, and an electrical drain pump of the tub (12).
- 45
11. The machine according to Claim 1, wherein the control system is configured for the purposes of controlling execution of at least one washing program including
- 50
- at least one washing step, during which the drum (13) is made to rotate in the presence of a washing liquid in the tub (12),
  - at least one rinsing step, during which the drum (13) is made to rotate in the presence of a rinsing
- 55
- liquid in the tub (12), and
- at least one centrifugation step, during which the drum (13) is made to rotate in the substantial absence of liquid in the tub (12),
- and wherein the control system is further configured for controlling execution of the washing step when the oscillating assembly (10) is in the above said at least one reclined position and for controlling execution of at least one of the rinsing step and the centrifugation step, preferably both the rinsing step and the centrifugation step, when the oscillating assembly (10) is in the above said at least one upright position.
12. The machine according to Claims 5 and 11, wherein the control system is configured for controlling execution of at least one of the rinsing step and the centrifugation step when the oscillating assembly (10) is in the above said first upright position.
13. A process for washing laundry in a laundry-washing machine for household use, particularly but not exclusively a machine according to one or more of Claims 1 to 12, having a structure (2) supporting an oscillating assembly (10), the oscillating assembly including a washing tub (12), a laundry drum (13) mounted in the tub (12) for rotating about a respective working axis (B) and a door (14) for opening and closing a tub opening (12a), the machine (1) being configured for executing at least one washing program including at least one washing step, during which the drum (13) is made to rotate in the presence of a washing liquid in the tub (12), at least one rinsing step, during which the drum (13) is made to rotate in the presence of a rinsing liquid in the tub (12), and at least one centrifugation step, during which the drum (13) is made to rotate in the substantial absence of liquid in the tub (12), the process comprising the steps of:
- prearranging the machine (1) such that the oscillating assembly (10) is supported by the structure (2) in a rotatable manner, to be manually displaceable about a substantially horizontal inclination axis (A), between at least one upright position, in which the working axis (B) of the drum (13) is set in a substantially vertical direction, and at least one reclined position, in which the working axis (B) of the drum (13) is set in a substantially horizontal direction;
  - performing loading of the laundry into the drum (13), with the door (14) open and the oscillating assembly (10) in the at least one upright position;
  - closing the door (14) and manually displacing the oscillating assembly (10) into the at least one reclined position;

- enabling execution of the washing program and causing locking of the door (14) in a closed condition;
- executing the washing step with the oscillating assembly (10) in the above said at least one reclined position;
- at the end of the washing step, causing automated displacement of the oscillating assembly (10) into the above said at least one upright position; executing at least one between the rinsing step and the centrifugation step, preferably both the rinsing step and the centrifugation step, with the oscillating assembly (10) in the above said at least one upright position; and
- at the end of the rinsing step or of the centrifugation step, causing unlocking of the door (14).

14. The process according to Claim 13, wherein at least one of

- enabling execution of the washing program,
- electrically supplying the machine and/or electrical components (16, 30) of the machine carried by the oscillating assembly (10), and
- locking of the door (14) in the closed condition

is caused by manual displacement of the oscillating assembly (10) from the at least one upright position to the at least one reclined position.

15. The process according to Claim 13 or Claim 14, wherein said automated displacement of the oscillating assembly (10) from the at least one reclined position to the at least one upright position is caused by the release of an accumulator of mechanical energy (26), such as a spring, that has been previously loaded following upon manual displacement of the oscillating assembly (10) from the at least one upright position to the at least one reclined position.

### Patentansprüche

1. Haushalts-Waschmaschine mit einer Schwenkeinrichtung (10) abstützenden Struktur (2), wobei die Schwenkeinrichtung eine Waschwanne (12) und eine um eine Arbeitsachse (B) drehbar in der Wanne (12) befestigte Wäschtrommel (13) aufweist, wobei die Wanne (12) und die Trommel (13) jeweils Zugangsöffnungen (12a, 13a) aufweisen, welche im Wesentlichen koaxial oder ausgerichtet nacheinander sind, wobei die Maschine (1) ferner Einrichtungen (EV, IN), zum Befüllen der Wanne (12) mit Flüssigkeit, Einrichtungen (OUT) zum Abführen von Flüssigkeit aus der Wanne (12), einen Motor (16) zum Antreiben der Trommel (13) und ein Steuersystem (17) umfassend Steuereinrichtungen (28, 29) aufweist, welches vom Benutzer der Maschine

(1) schaltbar sind, um das Starten oder das Ausführen eines Waschprogramms zu steuern, wobei die Schwenkeinrichtung (10) gleichfalls eine Tür (14) zum Öffnen und Schließen wenigstens der Zugangsöffnung (12a) der Wanne (12) aufweist, und die Schwenkeinrichtung (10) von der Struktur (2) in drehbarer Weise abgestützt wird, um verlagerbar zu sein, um eine im Wesentlichen horizontale Neigungsachse (A) zwischen wenigstens einer Aufrechtstellung, in welcher die Arbeitsachse (B) der Trommel (13) im Wesentlichen vertikal gestellt ist, und wenigstens einer geneigten Position, in welcher die Arbeitsachse (B) der Trommel (13) in eine im Wesentlichen horizontale Richtung gestellt ist, **dadurch gekennzeichnet, dass** die Struktur (2) und die Schwenkeinrichtung (10) so konfiguriert sind, dass die Schwenkeinrichtung (10) von Hand aus der wenigstens einen Aufrechtstellung in die wenigstens eine geneigte Position verlagerbar ist und dass die Steuereinrichtungen (28, 29) voreingestellt sind, um mittels einer Verlagerung der Schwenkeinrichtung (10) von Hand aus der wenigstens einen Aufrechtstellung in die wenigstens eine geneigte Position geschaltet werden.

2. Maschine nach Anspruch 1, wobei die Steuereinrichtungen (28, 29) voreingestellt sind, um die Maschine (1) und/oder an der Schwenkeinrichtung (10) befestigte elektrische Komponenten (16, 30) mit Elektrizität zu versorgen, nachdem die Schwenkeinrichtung (10) von Hand in die wenigstens eine geneigte Position verlagert worden ist.

3. Maschine nach Anspruch 1 oder 2, ferner umfassend Sicherheitseinrichtungen, einschließlich einer Türverriegelungsvorrichtung, welches von der Schwenkeinrichtung (10) getragen und schaltbar zwischen einem wirksamen Zustand und einem unwirksamen Zustand ist, wobei ein Öffnen der Tür (14) verhindert bzw. zugelassen wird und die Sicherheitseinrichtungen so voreingestellt sind, dass die Türverriegelungsvorrichtung den wirksamen Zustand einnimmt, wenn die Schwenkeinrichtung (10) in wenigstens eine im Wesentlichen vorbestimmte Winkelstellung gegenüber der im Wesentlichen horizontalen Neigungsachse (A) verlagert ist, insbesondere in die wenigstens eine geneigte Position.

4. Maschine nach einem der Ansprüche 1 bis 3, wobei in der wenigstens einen Aufrechtstellung die Antriebsachse (B) der Trommel (13) eine Neigung zwischen 75° und 90° gegenüber einer Horizontalebene aufweist und in der wenigstens einen geneigten Position die Antriebsachse (B) der Trommel (13) eine Neigung zwischen 0° und 15° gegenüber einer Horizontalebene einnimmt.

5. Maschine nach Anspruch 1 oder Anspruch 4, wobei

- die wenigstens eine Aufrechtposition eine erste Aufrechtposition und eine zweite Aufrechtposition umfasst und in der ersten Aufrechtposition die Neigung der Arbeitsachse (B) der Trommel (13) gegenüber einer Horizontalebene größer ist als in der zweiten Aufrechtposition. 5
6. Maschine nach Anspruch 3 oder 5, wobei die wenigstens eine im Wesentlichen vorbestimmte Winkelposition die oben genannte erste Aufrechtposition umfasst. 10
7. Maschine nach Anspruch 1, ferner umfassend eine Antriebseinrichtung (26) zum automatischen Verlagern der Schwenkeinrichtung (10) aus der wenigstens einen geneigten Position in die wenigstens eine Aufrechtposition. 15
8. Maschine nach Anspruch 1, ferner umfassend schaltbare Halteeinrichtungen (25) zum Halten der Schwenkeinrichtung (10) in der wenigstens einen geneigten Position oder in der wenigstens einen Aufrechtposition. 20
9. Maschine nach Anspruch 7 oder 8, wobei die Antriebseinrichtungen wenigstens einen mechanischen Energiespeicher (26), wie eine Feder, umfassen, welcher durch die oben genannte mechanische Verlagerung der Schwenkeinrichtung (10) aus der wenigstens einen Aufrechtposition in die wenigstens eine geneigte Position vorgespannt wird, wobei der wenigstens eine mechanische Energiespeicher (26) zufolge eine von der Steuereinrichtung gesteuerten Schaltens der Halteeinrichtung (25) entspannt wird, um eine Bewegung der Schwenkeinrichtung (10) aus der wenigstens einen geneigten Stellung in die wenigstens eine Aufrechtstellung zu verursachen. 25  
30  
35
10. Maschine nach einem der vorhergehenden Ansprüche, wobei 40
- wenigstens die Einrichtung zum Befüllen oder die Einrichtung zum Entleeren eine Leitung aufweist, welche jeweils einen Abschnitt an einem Gelenk (11) zwischen der Schwenkeinrichtung (10) und der Struktur (2) aufweist, und/oder 45
  - die Schwenkeinrichtung (10) wenigstens den Elektromotor (16) für den Antrieb der Trommel (13), oder eine elektrische Türverriegelungsvorrichtung oder eine elektrische Entleerungspumpe für die Wanne (12) unterstützt. 50
11. Maschine nach Anspruch 1, wobei das Steuersystem konfiguriert ist, um das Ausführen wenigstens eines Waschprogrammes zu steuern, einschließlich 55
- wenigstens einer Waschstufe, während welcher die Trommel (13) bei Vorliegen von Wasch-
- flüssigkeit in der Wanne (12) in Rotation versetzt wird,
- wenigstens eine Spülstufe, während welcher die Trommel (13) bei Vorliegen einer Spülflüssigkeit in der Wanne (12) in Umdrehung versetzt wird, und
  - wenigstens eine Schleuderstufe, während welcher die Trommel (13) bei im Wesentlichen Abwesenheit von Flüssigkeit in der Wanne (12) in Umdrehung versetzt wird,
- wobei das Steuersystem außerdem konfiguriert ist, um das Ausführen der Waschstufe zu steuern, wenn die Schwenkeinrichtung (10) in ihrer oben genannten wenigstens einen geneigten Position ist und zum Steuern der Ausführung von wenigstens der Spülstufe oder der Schleuderstufe, vorzugsweise von sowohl der Spülstufe als auch der Schleuderstufe, wenn sich die Schwenkeinrichtung (10) in ihrer oben genannten wenigstens einen Aufrechtposition befindet.
12. Maschine nach Anspruch 5 oder 11, wobei das Steuersystem konfiguriert ist, um die Ausführung wenigstens der Spülstufe oder der Schleuderstufe zu steuern, wenn sich die Schwenkeinrichtung (10) in der oben genannten ersten Aufrechtposition befindet.
13. Verfahren zum Wäschewaschen in einer Haushalts-Waschmaschine, insbesondere, aber nicht ausschließlich, einer Maschine gemäß wenigstens einem der Ansprüche 1 bis 12 mit einer Schwenkeinrichtung (10) halternden Struktur (2), wobei die Schwenkeinrichtung umfasst eine Waschwanne (12), eine in der Wanne (12) drehbar um eine geeignete Arbeitsachse (B) gelagerte Wäschetrommel (13) und eine Tür (14) zum Öffnen und Schließen einer Wannenöffnung (12a), wobei die Maschine (1) konfiguriert ist, um wenigstens ein Waschprogramm auszuführen, einschließlich wenigstens eine Waschstufe, während welcher die Trommel (13) bei Vorliegen von Waschflüssigkeit in der Wanne (12) in Rotation versetzt wird, wenigstens eine Spülstufe, während welcher die Trommel (13) bei Vorliegen von Spülflüssigkeit in der Wanne in Rotation versetzt wird und wenigstens eine Schleuderstufe, während welcher die Trommel (13) bei im Wesentlichen Abwesenheit von Flüssigkeit in der Wanne (12) in Rotation versetzt wird, wobei das Verfahren die folgenden Stufen umfasst:
- Voreinstellen der Maschine (1) derart, dass die Schwenkeinrichtung (10) von der Struktur (2) auf drehbare Weise gehalten wird, um von Hand um eine im Wesentlichen horizontale Neigung (A) zwischen wenigstens einer Aufrechtstellung, in welcher die Arbeitsachse (B) der Trommel (13) in eine im Wesentlichen vertikale Rich-

- tung gestellt ist, und wenigstens einer geneigten Position, in welcher die Arbeitsachse (B) der Trommel (13) in einer im Wesentlichen horizontale Richtung gestellt ist, zu verlagern;
- Einbringen von Wäsche in die Trommel (13) bei geöffneter Tür (14) und der Schwenkeinrichtung (10) in ihrer wenigstens einen Aufrechtstellung;
  - Schließen der Tür (14) und von Hand Verlagern der Schwenkeinrichtung (10) in die wenigstens eine geneigte Position;
  - Ermöglichen das Ausführen des Waschprogramms und Veranlassen des Verriegelns der Tür (14) in einen geschlossenen Zustand;
  - Ausführen der Waschstufe mit der Schwenkeinrichtung (10) in der oben genannten wenigstens einen geneigten Stellung;
  - zum Ende der Waschstufe Veranlassen einer automatischen Verlagerung der Schwenkeinrichtung (10) in die oben genannte wenigstens eine Aufrechtstellung; Ausführen wenigstens einer Spülstufe oder der Schleuderstufe, vorzugsweise von sowohl der Spülstufe als auch der Schleuderstufe, wobei sich die Schwenkeinrichtung (10) der oben genannten wenigstens einen Aufrechtstellung befindet; und
  - am Ende der Spülstufe oder der Schleuderstufe Bewirken, dass die Tür (14) entriegelt wird.
14. Verfahren nach Anspruch 13, wobei durch Verlagerung der Schwenkeinrichtung (10) von Hand aus der wenigstens einen Aufrechtstellung in die wenigstens eine geneigte Stellung wenigstens einer der folgenden Schritte ausgeführt wird:
- Ausführen des Waschprogramms,
  - Versorgen der Maschine und/oder von der Schwenkeinrichtung (10) getragener elektrischer Komponenten (16, 30) mit Elektrizität, und
  - Verriegeln der Tür (14) in der geschlossenen Stellung.
15. Verfahren nach Anspruch 13 oder Anspruch 14, wobei das automatische Verlagern der Schwenkeinrichtung (10) aus der wenigstens einen geneigten Stellung in die wenigstens eine Aufrechtstellung verursacht wird durch das Entspannen eines mechanischen Energiespeichers (26), wie einer Feder, welcher zuvor infolge Verlagerung der Schwenkeinrichtung (10) von Hand aus der wenigstens einen Aufrechtstellung in die wenigstens eine geneigte Stellung gespannt worden ist.

## Revendications

1. Machine à laver le linge à usage domestique, ayant une structure (2) supportant un ensemble oscillant

(10), l'ensemble oscillant comprenant une cuve de lavage (12) et un tambour de linge (13) monté dans la cuve (12) pour tourner autour d'un axe de travail (B) respectif, la cuve (12) et le tambour (13) ayant des ouvertures d'accès (12a, 13a) respectives qui sont sensiblement coaxiales ou alignées les unes par rapport aux autres, la machine (1) comprenant également des moyens (EV, IN) pour charger la cuve (12) avec le liquide, des moyens (OUT) pour vidanger le liquide de la cuve (12), un moteur (16) pour entraîner le tambour (13), un système de commande (17) comprenant des moyens de commande (28, 29) commutables par un utilisateur de la machine (1) pour commander le démarrage ou permettre l'exécution d'un programme de lavage, dans laquelle l'ensemble oscillant (10) comprend également une porte (14) pour ouvrir et fermer au moins l'ouverture d'accès (12a) de la cuve (12), dans laquelle l'ensemble oscillant (10) est supporté par la structure (2) d'une manière rotative, pour pouvoir être déplacé autour d'un axe d'inclinaison sensiblement horizontal (A) entre au moins une position droite dans laquelle l'axe de travail (B) du tambour (13) est dans une direction sensiblement verticale, et une position au moins inclinée dans laquelle l'axe de travail (B) du tambour (13) est dans une direction sensiblement horizontale,

**caractérisée en ce que** la structure (2) et l'ensemble oscillant (10) sont configurés de sorte que l'ensemble oscillant (10) est manuellement déplaçable de la au moins une position droite à la au moins une position inclinée, et **en ce que** les moyens de commande (28, 29) sont pré-agencés pour être commutés au moyen d'un déplacement manuel de l'ensemble oscillant (10) de la au moins une position droite à la au moins une position inclinée.

2. Machine selon la revendication 1, dans laquelle les moyens de commande (28, 29) sont pré-agencés pour permettre d'alimenter électriquement la machine (1) et/ou des composants électriques (16, 30) montés sur l'ensemble oscillant (10) suite au déplacement manuel de l'ensemble oscillant (10) dans la au moins une position inclinée.
3. Machine selon la revendication 1 ou la revendication 2, comprenant également des moyens de sécurité comprenant un dispositif de verrouillage de porte, qui est porté par l'ensemble oscillant (10) et commutable entre une condition opérationnelle et une condition non opérationnelle, dans laquelle l'ouverture de la porte (14) est empêchée ou autorisée, respectivement, les moyens de sécurité étant pré-agencés de sorte que le dispositif de verrouillage de porte adopte la position opérationnelle mentionnée ci-dessus lorsque l'ensemble oscillant (10) est déplacé dans au moins une position angulaire sensiblement prédéterminée par rapport audit axe d'inclinaison

sensiblement horizontal (A), en particulier dans ladite au moins une position inclinée.

4. Machine selon l'une quelconque des revendications 1 à 3, dans laquelle :
- 5 dans la au moins une position droite, l'axe d'entraînement (B) du tambour (13) a une inclinaison comprise entre 75° et 90° par rapport à un plan horizontal ; et
- 10 dans la au moins une position inclinée, l'axe d'entraînement (B) du tambour (13) a une inclinaison comprise entre 0° et 15° par rapport à un plan horizontal.
5. Machine selon la revendication 1 ou la revendication 4, dans laquelle la au moins une position droite comprend une première position droite et une seconde position droite, dans la première position droite, l'inclinaison de l'axe de travail (B) du tambour (13) par rapport à un plan horizontal étant plus importante que dans la seconde position droite.
- 20 6. Machine selon les revendications 3 et 5, dans laquelle ladite au moins une position angulaire sensiblement prédéterminée comprend ladite première position droite ci-dessus.
- 25 7. Machine selon la revendication 1, comprenant en outre des moyens d'entraînement (26), pour déplacer d'une manière automatique, l'ensemble oscillant (10) de la au moins une position inclinée à la au moins une position droite.
- 30 8. Machine selon la revendication 1, comprenant en outre des moyens de retenue commutables (25) pour maintenir l'ensemble oscillant (10) dans au moins l'une parmi ladite au moins une position inclinée et ladite au moins une position droite.
- 35 9. Machine selon les revendications 7 et 8, dans laquelle les moyens d'entraînement comprennent au moins un accumulateur d'énergie mécanique (26) tel qu'un ressort, qui est chargé suite audit déplacement manuel ci-dessus de l'ensemble oscillant (10) de ladite au moins une position droite à ladite au moins une position inclinée, le au moins un accumulateur d'énergie mécanique (26) étant libéré suite à une commutation des moyens de retenue (25) commandée par le système de commande, pour provoquer un mouvement de l'ensemble oscillant (10) de ladite au moins une position inclinée à ladite au moins une position droite.
- 50 10. Machine selon l'une quelconque des revendications précédentes, dans laquelle :
- 55 au moins l'un parmi les moyens de chargement

et les moyens de vidange comprend un conduit ayant une section respective au niveau d'une articulation (11) entre l'ensemble oscillant (10) et la structure (2), et/ou

l'ensemble oscillant (10) supporte au moins l'un parmi le moteur électrique (16) pour entraîner le tambour (13), un dispositif de verrouillage de porte électrique, et une pompe de vidange électrique de la cuve (12).

11. Machine selon la revendication 1, dans laquelle le système de commande est configuré à des fins d'exécution de commande d'au moins un programme de lavage comprenant :

au moins une étape de lavage, pendant laquelle le tambour (13) tourne en présence d'un liquide de lavage dans la cuve (12),

au moins une étape de rinçage, pendant laquelle le tambour (13) tourne en présence d'un liquide de rinçage dans la cuve (12), et

au moins une étape de centrifugation, pendant laquelle le tambour (13) tourne en l'absence sensible de liquide dans la cuve (12),

et dans laquelle le système de commande est en outre configuré pour commander l'exécution de l'étape de lavage lorsque l'ensemble oscillant (10) est dans ladite au moins une position inclinée ci-dessus et pour commander l'exécution d'au moins l'une parmi l'étape de rinçage et l'étape de centrifugation, de préférence à la fois l'étape de rinçage et l'étape de centrifugation, lorsque l'ensemble oscillant (10) est dans ladite au moins une position droite ci-dessus.

12. Machine selon les revendications 5 et 11, dans laquelle le système de commande est configuré pour commander l'exécution d'au moins l'une parmi l'étape de rinçage et l'étape de centrifugation lorsque l'ensemble oscillant (10) est dans ladite première position droite ci-dessus.

13. Procédé pour laver du linge dans une machine à laver le linge à usage domestique, en particulier, mais non exclusivement, une machine selon une ou plusieurs des revendications 1 à 12, ayant une structure (2) supportant un ensemble oscillant (10), l'ensemble oscillant comprenant une cuve de lavage (12), un tambour de linge (13) monté dans la cuve (12) pour tourner autour d'un axe de travail (B) respectif et une porte (14) pour ouvrir et fermer une ouverture de cuve (12a), la machine (1) étant configurée pour exécuter au moins un programme de lavage comprenant au moins une étape de lavage pendant laquelle le tambour (13) tourne en présence d'un liquide de lavage dans la cuve (12), au moins une étape de rinçage pendant laquelle le tambour (13) tourne en présence d'un liquide de rinçage dans

la cuve (12), et au moins une étape de centrifugation pendant laquelle le tambour (13) tourne en l'absence sensible de liquide dans la cuve (12), le procédé comprenant les étapes consistant à :

5 pré-agencer la machine (1) de sorte que l'ensemble oscillant (10) est supporté par la structure (2) d'une manière rotative, pour être manuellement déplaçable autour d'un axe d'inclinaison sensiblement horizontal (A), entre au moins une position droite dans laquelle l'axe de travail (B) du tambour (13) est dans une direction sensiblement verticale, et au moins une position inclinée dans laquelle l'axe de travail (B) du tambour (13) est dans une position sensiblement horizontale ; 10

réaliser le chargement du linge dans le tambour (13), avec la porte (14) ouverte et l'ensemble oscillant (10) dans la au moins une position droite ; 15

fermer la porte (14) et déplacer manuellement l'ensemble oscillant (10) dans la au moins une position inclinée ; 20

permettre l'exécution du programme de lavage et provoquer le verrouillage de la porte (14) dans une condition fermée ; 25

exécuter l'étape de lavage avec l'ensemble oscillant (10) dans ladite au moins une position inclinée ci-dessus ;

à la fin de l'étape de lavage, provoquer le déplacement automatique de l'ensemble oscillant (10) dans ladite au moins une position droite ci-dessus ; exécuter au moins l'une entre l'étape de rinçage et l'étape de centrifugation, de préférence à la fois l'étape de rinçage et l'étape de centrifugation, avec l'ensemble oscillant (10) dans ladite au moins une position droite ci-dessus ; et 30

à la fin de l'étape de rinçage ou de l'étape de centrifugation, provoquer le déverrouillage de la porte (14). 40

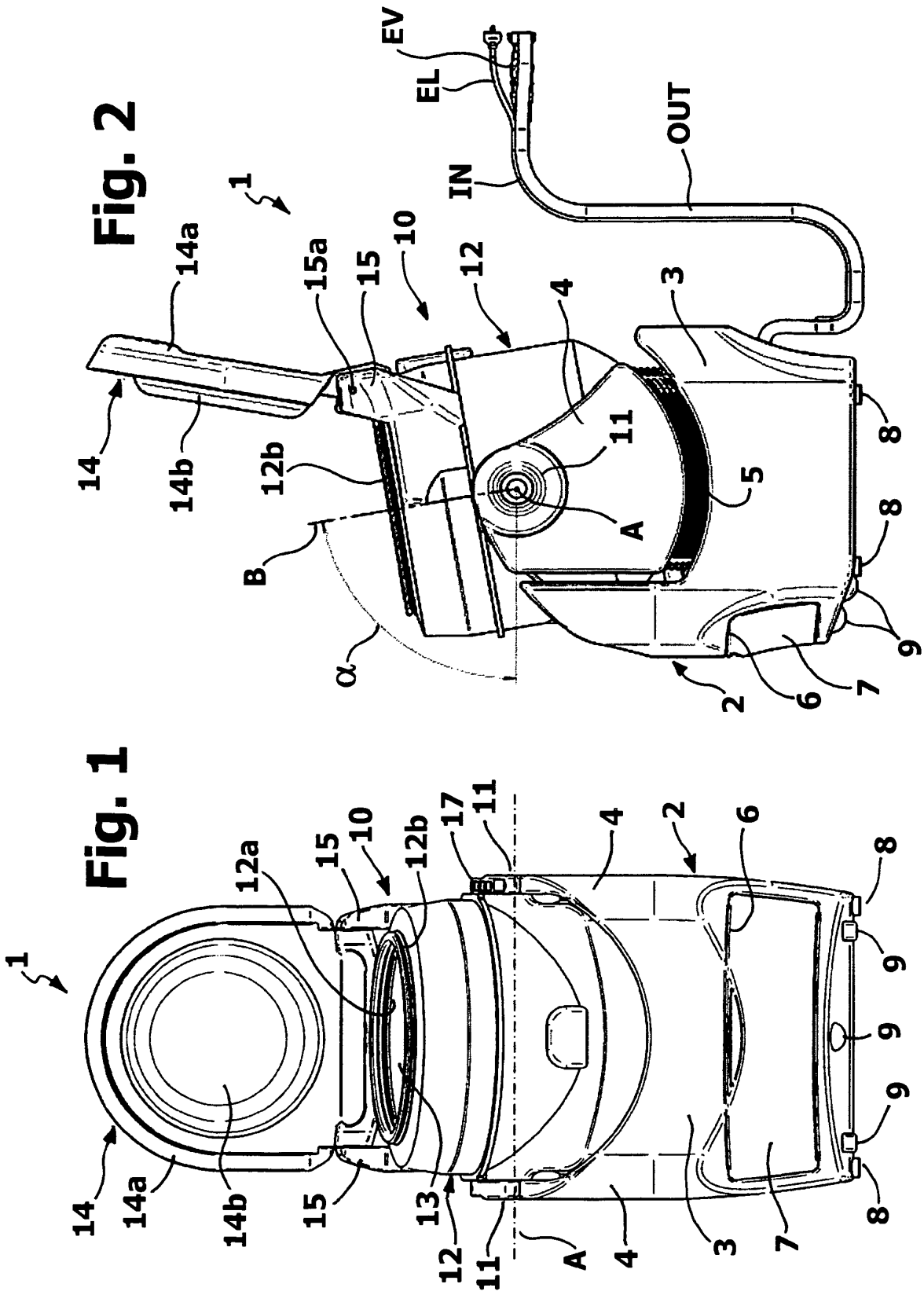
14. Procédé selon la revendication 13, dans lequel au moins une étape parmi les étapes suivantes consistant à : 45

permettre l'exécution du programme de lavage, alimenter électriquement la machine et/ou les composants électriques (16, 30) de la machine portés par l'ensemble oscillant (10), et 50

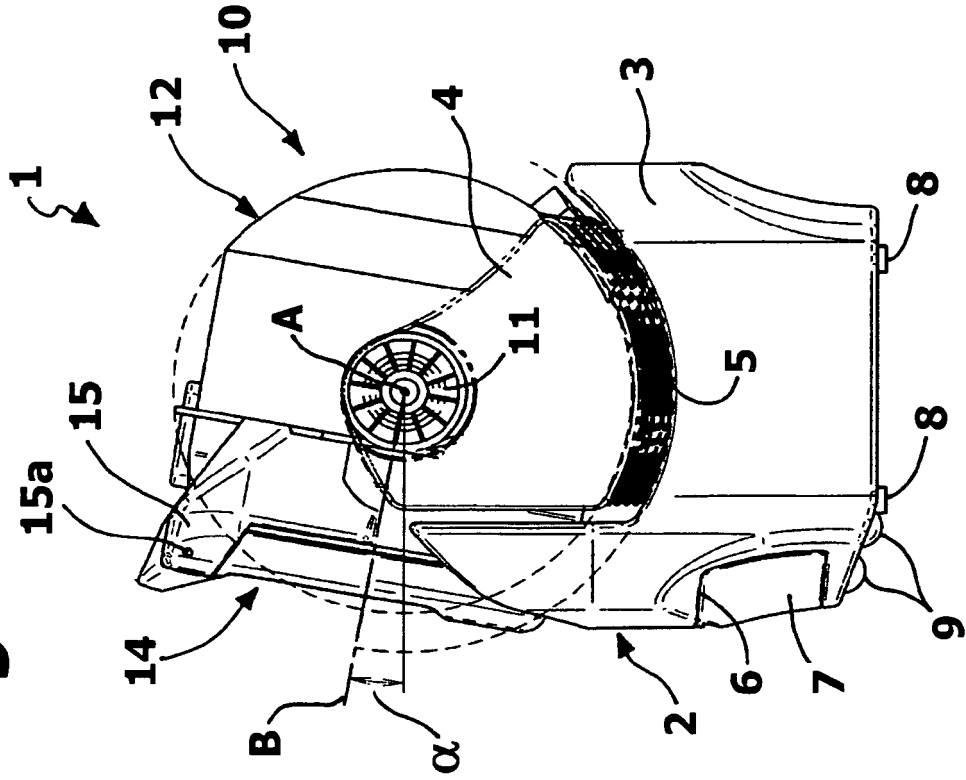
verrouiller la porte (14) dans la condition fermée, est provoquée par le déplacement manuel de l'ensemble oscillant (10) de la au moins une position droite à la au moins une position inclinée. 55

15. Procédé selon la revendication 13 ou la revendication 14, dans lequel ledit déplacement automatique de l'ensemble oscillant (10) de la au moins une po-

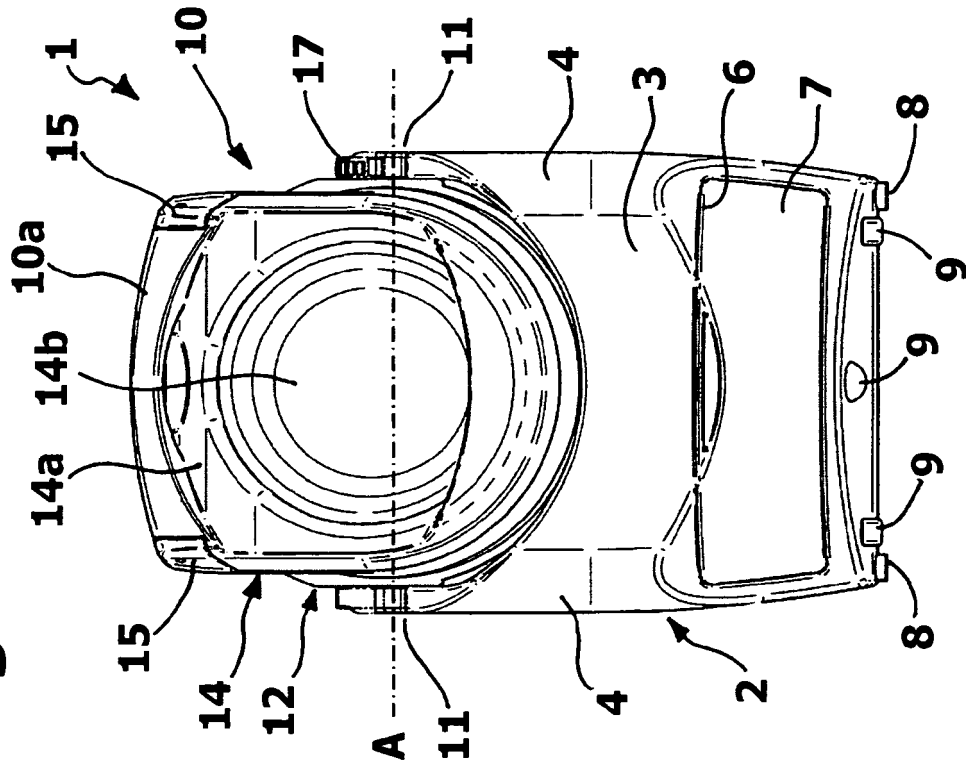
sition inclinée à la au moins une position droite est provoqué par la libération d'un accumulateur d'énergie mécanique (26) tel qu'un ressort, qui a été préalablement chargé suite au déplacement manuel de l'ensemble oscillant (10) de la au moins une position droite à la au moins une position inclinée.



**Fig. 4**



**Fig. 3**



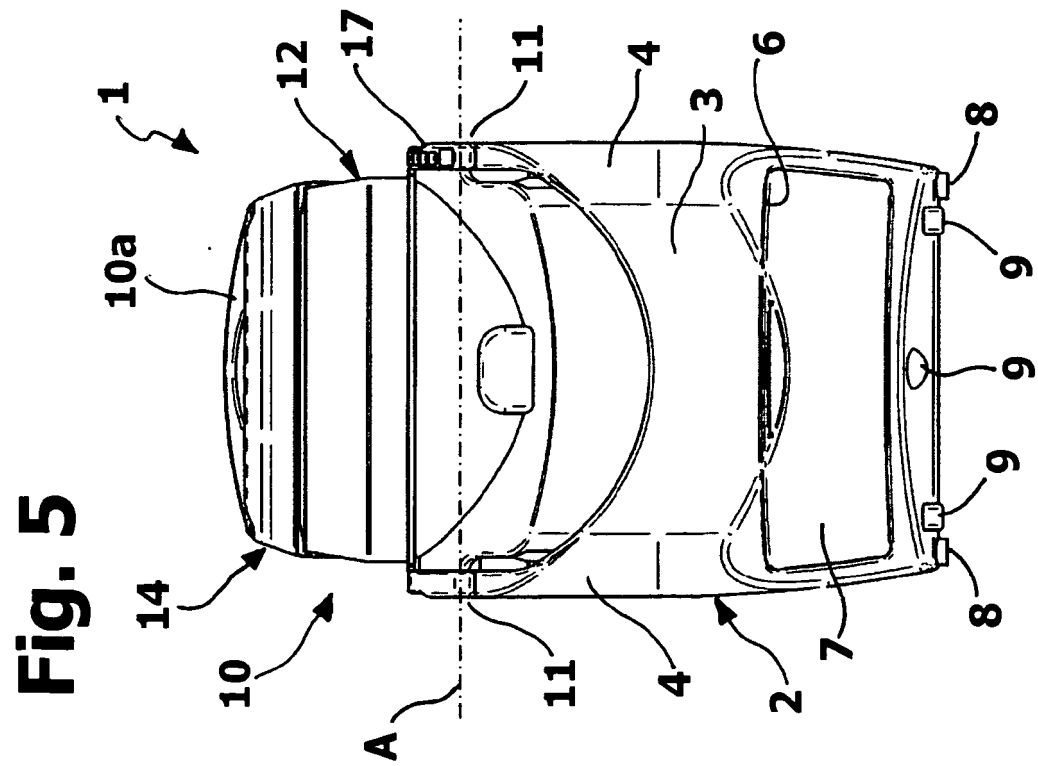
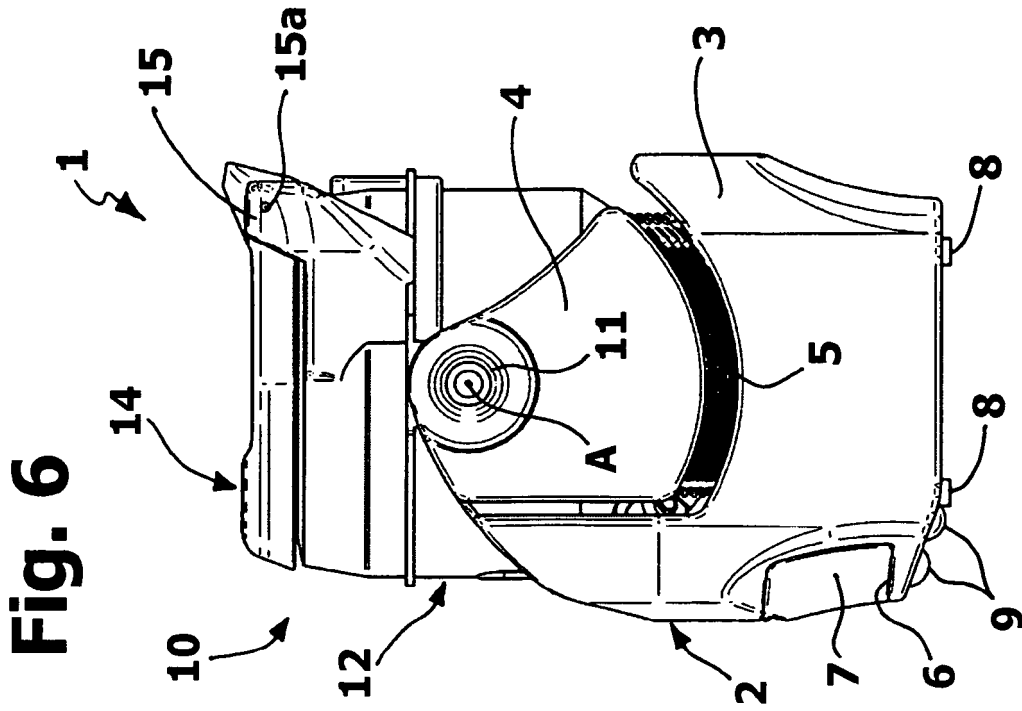


Fig. 8

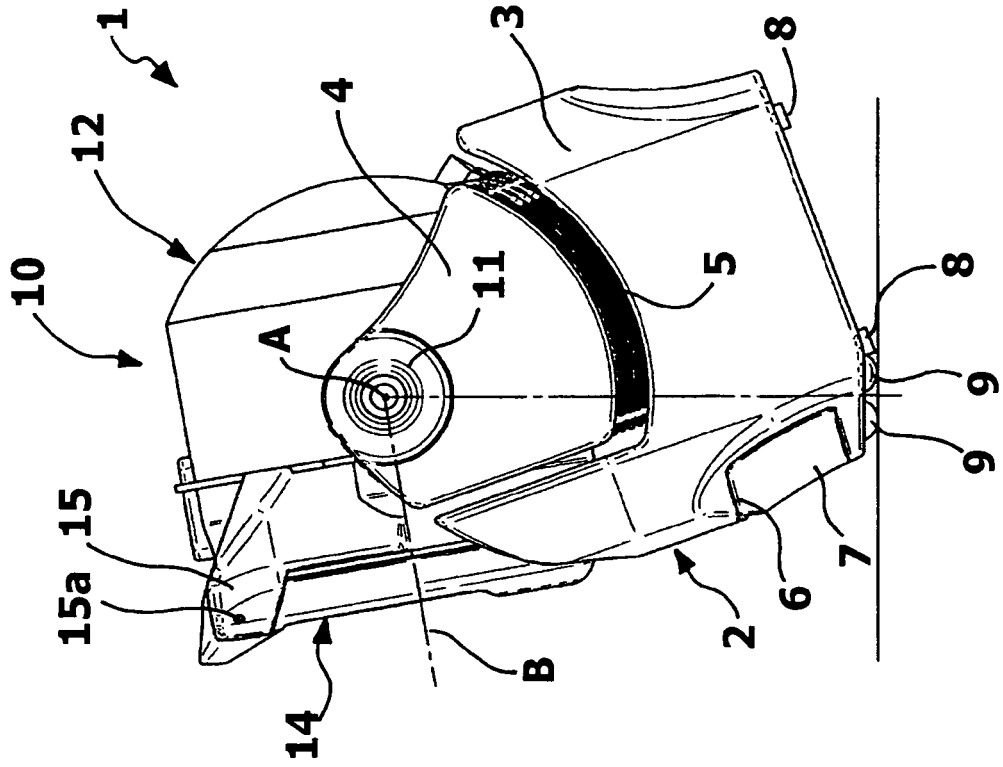
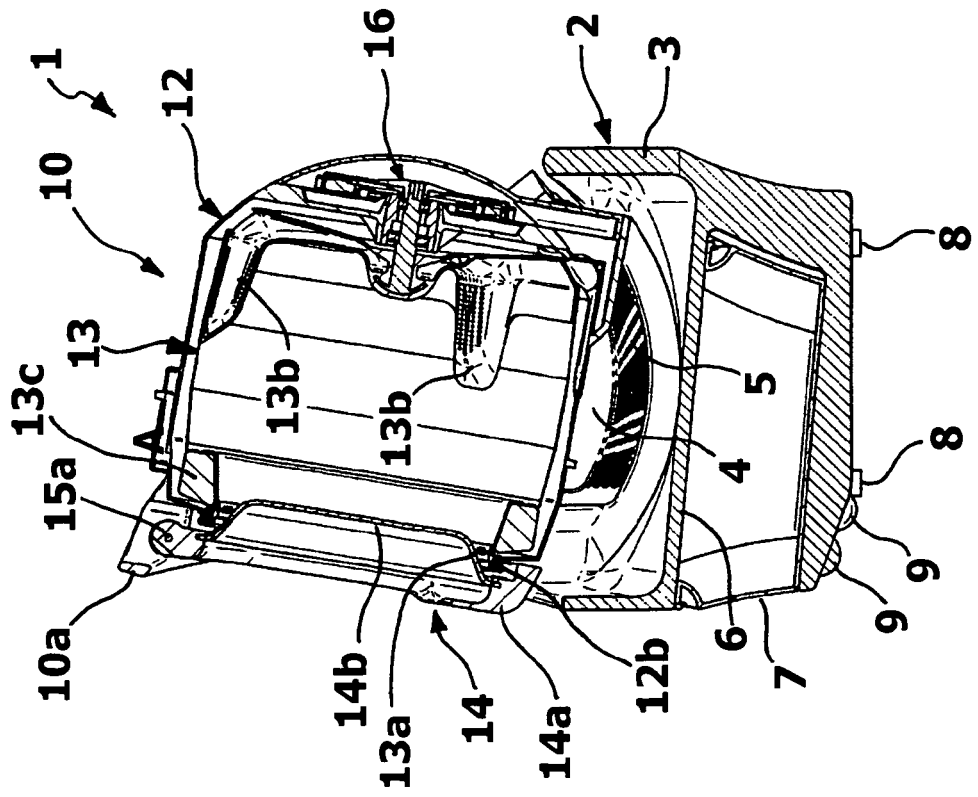
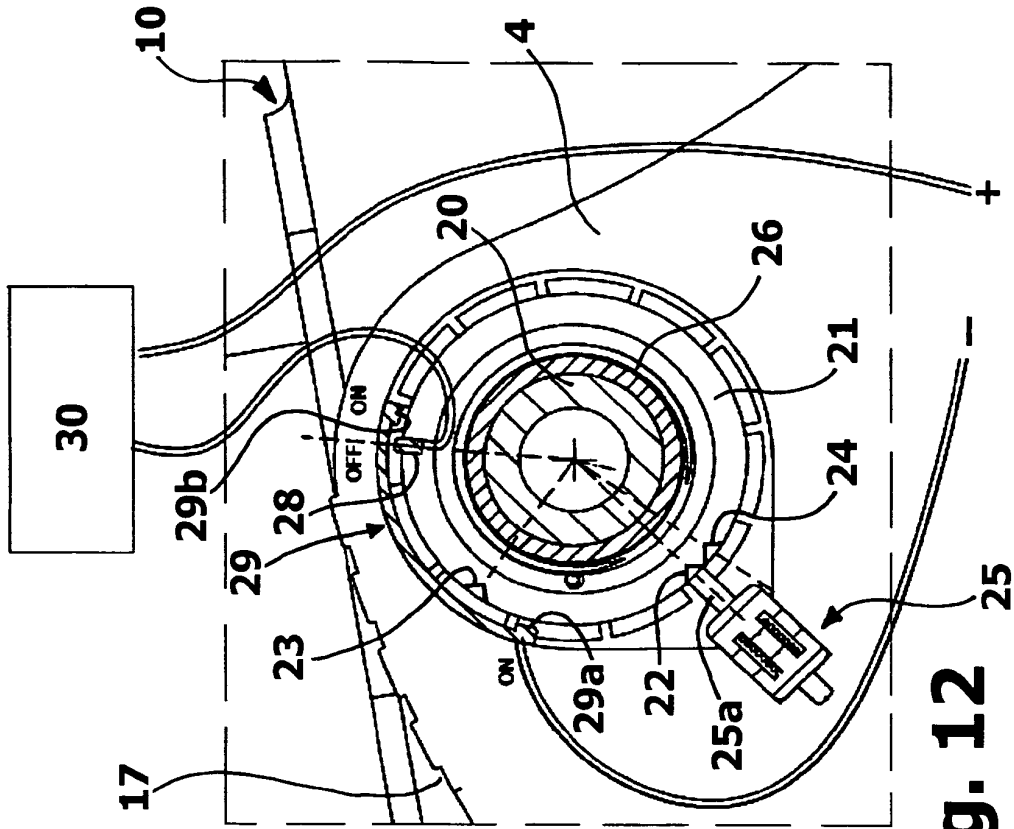


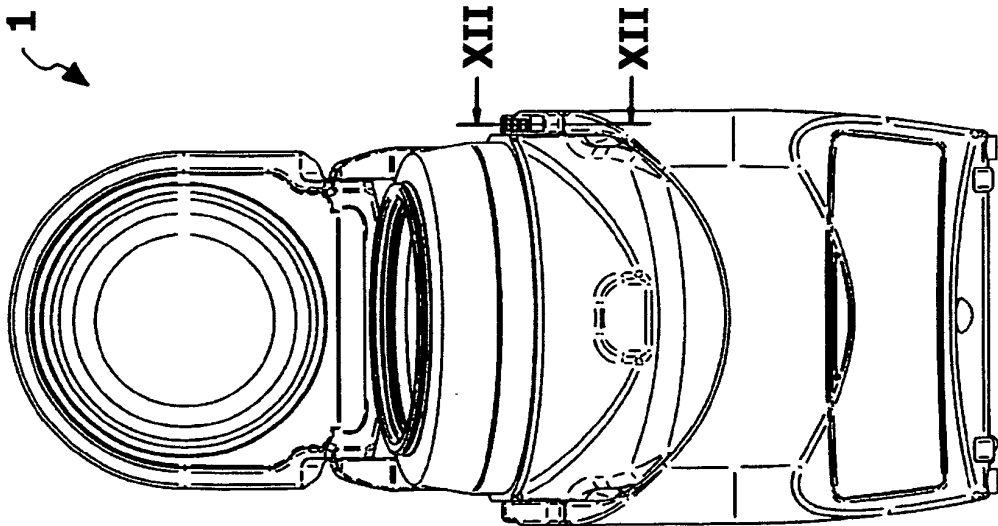
Fig. 7



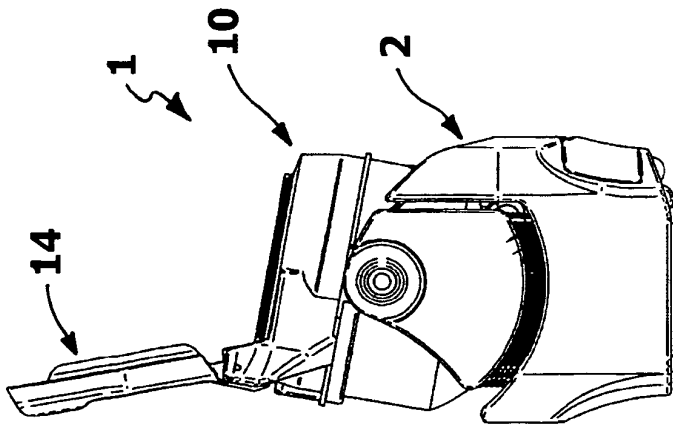




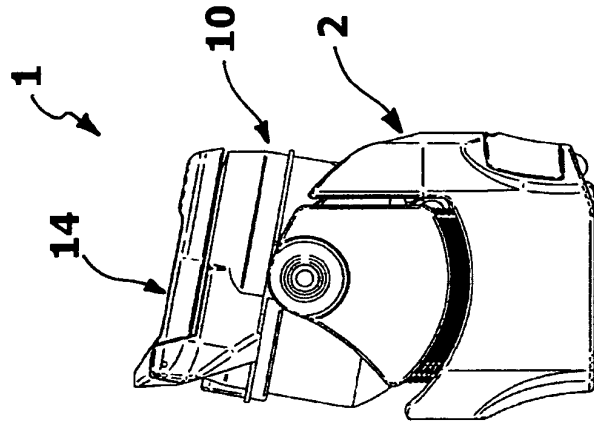
**Fig. 12**



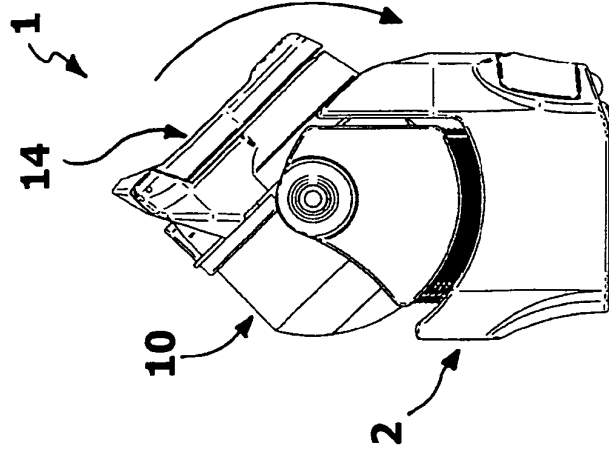
**Fig. 11**



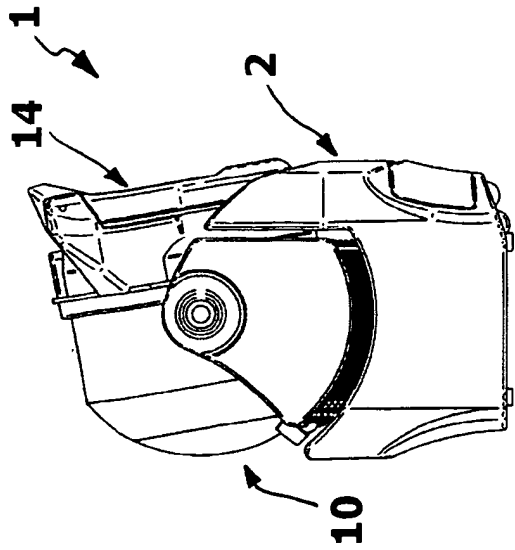
**Fig. 13**



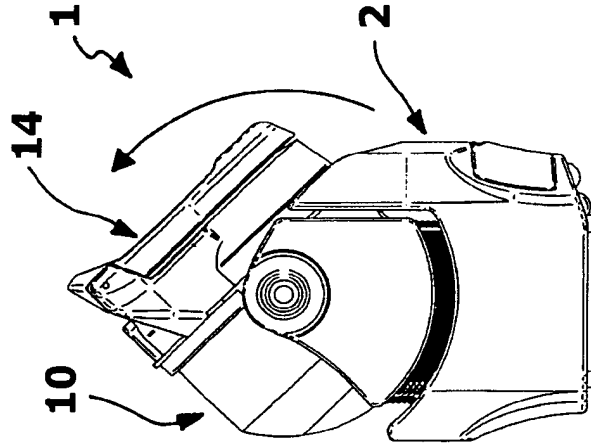
**Fig. 14**



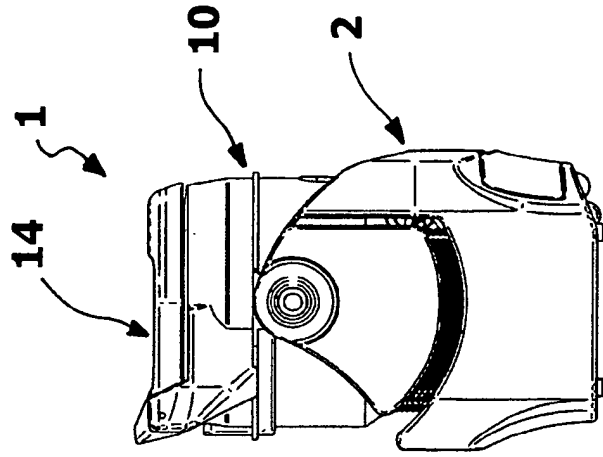
**Fig. 15**



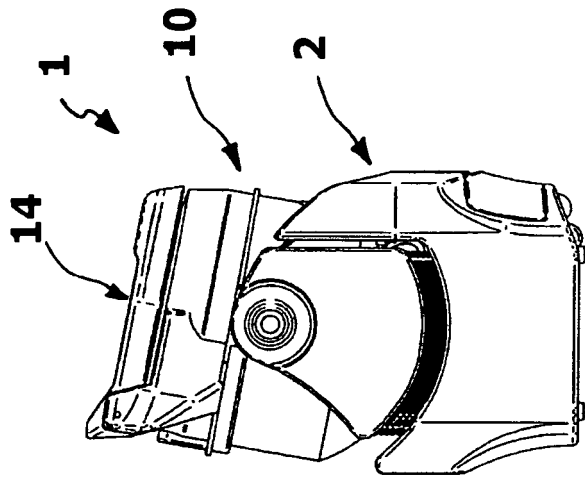
**Fig. 16**



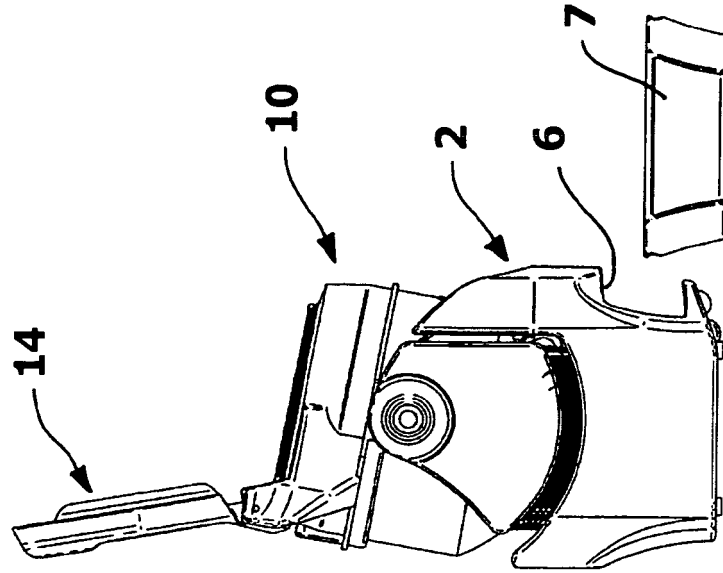
**Fig. 17**



**Fig. 18**



**Fig. 19**



**Fig. 20**

**REFERENCES CITED IN THE DESCRIPTION**

*This list of references cited by the applicant is for the reader's convenience only. It does not form part of the European patent document. Even though great care has been taken in compiling the references, errors or omissions cannot be excluded and the EPO disclaims all liability in this regard.*

**Patent documents cited in the description**

- US 5327603 A [0008] [0009]