

(19)



(11)

EP 2 488 330 B2

(12)

NEW EUROPEAN PATENT SPECIFICATION

After opposition procedure

(45) Date of publication and mention of the opposition decision:
02.05.2018 Bulletin 2018/18

(51) Int Cl.:
B26B 21/44 (2006.01)

(45) Mention of the grant of the patent:
29.07.2015 Bulletin 2015/31

(86) International application number:
PCT/US2010/052776

(21) Application number: **10770920.6**

(87) International publication number:
WO 2011/047221 (21.04.2011 Gazette 2011/16)

(22) Date of filing: **15.10.2010**

(54) **LUBRICATION BOX FOR A WET SHAVING IMPLEMENT**

SCHMIERBOX FÜR EIN NASSRASIERGERÄT

BOÎTIER DE LUBRIFICATION POUR UN ACCESSOIRE DE RASAGE HUMIDE

(84) Designated Contracting States:
AL AT BE BG CH CY CZ DE DK EE ES FI FR GB GR HR HU IE IS IT LI LT LU LV MC MK MT NL NO PL PT RO RS SE SI SK SM TR

• **HOBSON, SR., Wayne**
Shelton, CT 06484 (US)

(30) Priority: **16.10.2009 US 279148 P**

(74) Representative: **dompatent von Kreisler Selting Werner - Partnerschaft von Patent- und Rechtsanwälten mbB**
Deichmannhaus am Dom
Bahnhofsvorplatz 1
50667 Köln (DE)

(43) Date of publication of application:
22.08.2012 Bulletin 2012/34

(73) Proprietor: **Edgewell Personal Care Brands, LLC**
Chesterfield, MO 63017 (US)

(56) References cited:
EP-A1- 1 157 792 WO-A1-96/02369
WO-A1-03/064121 WO-A1-2004/110707
US-A- 4 170 821 US-A- 5 493 778
US-A1- 2005 120 559

(72) Inventors:
 • **BURGIO, Paul**
St. Paul, MN 55110 (US)
 • **KRAUSS, Gordon**
Ann Arbor, MI 48103 (US)
 • **COOPE-EPSTEIN, Janet**
Norwalk, CT 06851 (US)

• **LEVINA M. ET AL: 'Principles and application of ultrasound in Pharmaceutical powder compression' PHARMACEUTICAL RESEARCH**
vol. 17, no. 3, 2000, pages 257 - 265

EP 2 488 330 B2

Description

BACKGROUND OF THE INVENTION

Technical Field

[0001] The present invention is generally directed to a lubrication box for a wet shaving implement in general and, more particularly, to a mechanically assembled lubrication box that provides lubrication during shaving.

Background Information

[0002] Wet shaving implements generally consist of a shaving cartridge, also commonly known as a razor cartridge, and a handle. The shaving cartridge can be fixedly, or pivotally, attached to the handle. In addition, the shaving cartridge might be affixed to the handle such that, after several uses, a spent shaving cartridge can be replaced with a new shaving cartridge on the same handle. Such handles and shaving cartridges are often referred to as "system razors." Alternatively, the shaving cartridge can be affixed to the handle such that it is not intended to be removed from the handle during normal use and, once the shaving cartridge is spent, the entire shaving implement is discarded and an entirely new shaving implement is used in the now-discarded shaving implement's place. Such shaving implements are often referred to as "disposable razors." Shaving cartridges generally include a guard, a cap, and at least one blade. Prior art guards are located forward of the blade(s) and acts to flatten and/or pre-stretch the skin prior to encountering the blade. Prior art caps are often located aft of the blade(s) and, in addition to flattening the skin after the skin has been shaved, can also provide lubrication and/or other shaving aids to the recently-shaved skin. Typically, the lubrication and/or shaving aids are provided by a lubrication strip that is affixed to the cap.

[0003] In many cases, these lubrication strips utilize two components: a water soluble component that is dispersed throughout a water insoluble matrix. The water insoluble matrix maintains the integrity of the lubrication strip during normal use, permitting water soluble components to dissolve in the water present during normal shaving. Once dissolved in water, the water soluble shaving aid leaches onto the surface to be shaved, providing a shaving benefit. These lubrication strips are typically adhered to or mechanically fastened to the wet-shave razor cartridge. These forms of lubrication strips have deficiencies. At first, the shaving aid tends to leach superfluously during first few shaves. However, the amount of water soluble shaving aid lessens with each subsequent shave, thereby dissipating and often outlasted by the other components of the razor cartridge. Accordingly, the last several shaves also provide insufficient lubrication to the surface being shaved. Furthermore, current insoluble matrices do not permit complete leaching of all shaving aid, and are thus wasteful.

[0004] WO-A-96/02369 discloses a lubrication box, comprising a first portion of the lubrication box, = the first portion having a skin-engaging surface and at least one sidewall, the skin-engaging surface and the at least one side walls forming a cavity, holes extending through the skin-engaging surface of the first portion, a shaving aid material disposed into the cavity, the shaving aid at least partially filling at least one of the holes in the skin-engaging surface and at least a portion of the cavity; and a second portion of the lubrication box, the second portion being attached to the first portion such that the cavity is substantially closed.

[0005] Other wet-shave razors embed lubrication elements, such as U.S.-A-5,711,076 teach a co-extruded core and sheath set-up, where the water soluble core is co-extruded with a water insoluble sheath. The sheath portion according to US-A-5,711,076 includes holes through which dissolved core material leaches during normal shaving. However, Tseng, and similar lubrication devices also have deficiencies. These deficiencies include, among others, limited flexibility due to the co-extruded/co-molded manufacturing process; high temperatures and pressures required in extrusion and molding processes that tend to degrade the active shaving aid ingredients; and the fact that the co-molded/co-extruded set-up provides substantially problems when the core swells during normal use.

[0006] Accordingly, it is an object of the present invention to provide a lubrication agent and method of manufacture that improves the effectiveness and life expectancy of lubrication agents.

DISCLOSURE OF THE INVENTION

[0007] The invention provides a lubrication box according to claim 1 and a method of making a lubrication box according to claim 16. The dependent claims relate to individual embodiments of the invention.

[0008] According to one aspect of the present invention, a lubrication box includes a first portion, a shaving aid material, and a second portion. The first portion of the lubrication box has a skin-engaging surface and at least one sidewall that, together, form a cavity. There are at least two holes extending through the skin-engaging surface of the first portion. The shaving aid material (referred to hereinbelow as shaving aid) is ultrasonically compressed (also known as ultrasonically compacted) into the cavity such that it at least partially fills at least one of the holes in the skin-engaging surface and at least a portion of the cavity. The second portion of the lubrication box is attached to the first portion such that the cavity is substantially closed. A gap exists in the cavity between the shaving aid and the second portion of the lubrication box to permit the shaving aid material to expand during normal use.

[0009] According to another aspect of the invention, the shaving aid is distributed into the cavity in a series of layers (e.g., first, second, third, or more).

[0010] According to a further aspect of the present invention, the various layers of shaving aid can be of the same or different color, amount and/or chemical composition as one or more of the other layers of shaving aid.

[0011] According to an even further aspect of the present invention, the second portion of the lubrication box can include support structures that extend into the cavity to a position near or directly in contact with the shaving aid.

[0012] These and other aspects of the present invention are achieved by the apparatus and method of making the present invention disclosed herein. The invention will be clear to one of skill in the art in light of the Detailed Description and Drawings provided.

BRIEF DESCRIPTION OF THE SEVERAL VIEWS OF THE DRAWINGS

[0013]

Fig. 1 depicts a front view of one embodiment of a wet shaving cartridge of the present invention;
 Fig. 1A depicts a front view of another embodiment of a wet shaving cartridge of the present invention;
 Fig. 1B depicts a front view of a further embodiment of a wet shaving cartridge of the present invention;
 Fig. 1C depicts a front view of an even further embodiment of a wet shaving cartridge of the present invention;

Fig. 2 depicts a cross-sectional view along line II-II of the cartridge of Fig. 1 on a razor handle;

Fig. 3 depicts an isometric view of one embodiment of a lubrication box of the present invention;

Fig. 4 depicts a cut-away view along line IV-IV of the first portion of the lubrication box of Fig. 3 with a first layer of shaving aid therein;

Fig. 4A depicts a cut-away view along line IV-IV of a second layer of shaving aid in the first portion of the lubrication box of Fig. 4;

Fig. 4B depicts a cut-away view along line IV-IV of a third layer of shaving aid in the first portion of the lubrication box of Fig. 4A;

Fig. 5 depicts a cut-away view along line V-V of one embodiment of a second portion of the lubrication box affixed to the first portion of the lubrication box of Fig. 4A;

Fig. 5A depicts another embodiment of the second portion of the lubrication box of Fig. 3;

Fig. 5B depicts a further embodiment of the second portion of the lubrication box of Fig. 3;

Fig. 6 depicts a step in the method of making a lubrication box;

Fig. 6A depicts another step in the method of making a lubrication box;

Fig. 6B depicts a further step in the method of making a lubrication box;

Fig. 6C depicts a further step in the method of making a lubrication box;

Fig. 6D depicts a further step in the method of making a lubrication box; and

Fig. 6E depicts a further step in the method of making a lubrication box.

DETAILED DESCRIPTION OF THE INVENTION

[0014] Referring to Figs. 1, 1A, 1B, and 1C several embodiments of the shaving cartridge 102 of the present invention are shown. The shaving cartridge 102 of the present invention includes at least a frame 104, at least one razor blade 106, and a lubrication box 108.

[0015] The shaving cartridge 102 of the present invention is often used in conjunction with a handle 10 (see e.g., Fig. 2). The handle 10 is connected to the shaving cartridge 102, either pivotally or fixedly. The handle 10 can be connected to the shaving cartridge 102 in any suitable manner. For example, the handle 10 can be permanently connected to the razor cartridge 102, as is well known in disposable wet shaving implements. Alternatively, the handle can be selectively detachable from the shaving cartridge, as is well known in system wet shaving implements. The handle 10 can be made of any suitable materials and is, typically, ergonomically shaped such that it is easy to hold by the end user during shaving.

[0016] The shaving cartridge 102 of the present invention includes a frame 104 and at least one blade 106. The frame 104, which can be made of one or more distinct pieces, typically forms an opening 105 sized to accommodate razor blade(s) 106 (discussed *infra*). In some embodiments, such as the one shown in Fig. 1, the frame 104 includes a guard 12 in front of the blades 106. In these embodiments, the guard 12 can be of any suitable type known in the art.

[0017] The frame 104 can be made of any suitable material. Molded polymeric materials, or plastics, have proven to be the most effective. The frame 104 is also often either permanently connected to a handle 10 or includes connectors (not shown) such that a user can selectively attach and detach the cartridge from a handle 10.

[0018] The guard 12 is, generally, disposed lengthwise on the frame forward of the blades 106 and includes an outer skin-engaging surface 14. The guard 12 may be made of any suitable material known (e.g., rubber) to those of skill in the art and may include additional elements, such as one or more protrusions 16 that flex when in contact with the skin during normal shaving. The guard 12 generally stretches, flattens and otherwise prepares the skin prior to the skin encountering the sharpened blade tips 22. Guards 12 are well known in the art and will therefore not be discussed in detail further herein other than to point out that the present invention is not limited to being used with any particular type of guard 12.

[0019] The opening 105 in the frame 104 is sized and shaped to accommodate razor blades 106 positioned therein. Any suitable number of blades 106 (e.g., one, two, three, four, five, six or more) can be positioned within the opening 105 of the frame 104. Generally, the opening

105 is larger in shaving cartridges 102 having more blades 106, and smaller for shaving cartridges 102 having fewer blades 106. Each blade 106 is generally planar and defines a length 18 and a width 20 and is disposed in the opening 105 of the frame 104 such that the sharpened blade tip 22 is appropriately angled for shaving. In embodiments having more than one blade 106, the blades 106 are generally positioned in parallel relation to one another between the front 58 and rear 60 of the frame 104. Each of the blades 106 has a front side 24 and a rear side (not shown) that extend along the length 18 of the blade 106 on opposing sides. A sharpened blade tip 22 extends along at least a portion of a blade 106 width 20 on the front side 24. Each blade 106 is disposed on the frame 104 such that the sharpened blade tip 22 of each blade 106 is located substantially near the shave plane. In other words, the sharpened blade tip 22 of each blade 106 may be substantially contiguous with, slightly above, or slightly below the shave plane. Furthermore, each blade 106 may be mounted on the frame 104 such that the sharpened blade tip 22 is movable relative to the shave plane under forces encountered during normal shaving. For example, in some embodiments, the sharpened blade tip 22 may be located above the shave plane when the shaving cartridge 102 is at rest, but may deflect to a position below the shave plane under the forces on the blade 106 during normal shaving. The location of each blade 106 relative to the shave plane is independent to the location of each of the other blade(s) 106 relative to the shave plane.

[0020] Typically, blades 106 are made of flexible material and are supported in the frame 104 to prevent, or at least somewhat inhibit, flexing of the blades 106 during normal shaving. Several manners for supporting the blades 106 are known in the art. For example, in some embodiments, each blade 106 may be welded to a bent blade support (see e.g., Fig. 2) that provides a rigid support structure to the blades 106.

[0021] Referring to, e.g., Figs. 3, 4, 4A and 4B, according to one embodiment of the present invention, a lubrication box 108 includes a first box portion 28, a shaving aid 30, and a second box portion 32. One embodiment of the lubrication box 108 of the present invention is shown, separate from the frame 104, in Fig. 2. The lubrication box 108 is attached to the frame 104, directly or indirectly. For example, as shown in Fig. 1, the lubrication box 108 can be located aft of the blade(s) 106. Or, as shown in Fig. 1A, in other embodiments, the lubrication box 108 can be located forward of the blade(s) 106. In further embodiments, as shown in Fig. 1B, the lubrication box 108 can be located forward and aft of the blade(s) 106. And, in even further embodiments, as shown in Fig. 1C, the lubrication box 108 can substantially surround the blade(s) 106.

[0022] One embodiment of the first portion 28 of the lubrication box 108 can be seen in Fig. 3. The first portion 28 includes a skin-engaging surface 34 and at least one side wall 36 that extend(s) from the skin-engaging sur-

face 34 to create a cavity 40. The skin-engaging surface 34 can be of any suitable shape and size and includes at least two holes 38 extending into the cavity. As shown in FIGS. 1, 1A and 1B, the skin-engaging surface 34 can be generally rectangular and is approximately 3mm in width and approximately 40mm in length. Alternatively, as shown in Fig. 1C, the skin-engaging surface 34 can be generally oval with a center hole through which a shaving cartridge 102 can pass. However, the present invention is not limited by the shapes and/or size shown and disclosed, and can be of any shape suitable to the designer. Likewise, the at least two holes 38 can be of any suitable size and shape, depending on the needs and wants of the designer. Although the at least two holes 38 are shown in the FIGS. as being in a single row, they can be arranged in any suitable pattern, including multiple rows, and symmetrical and asymmetrical patterns. The first portion 28 can be made of any suitable material, including, but not limited to, plastics, metals, and rubber. Preferably, the entire first portion 28 is a unitary piece made from a single piece of material; however the present invention is not so limited. For example, although not shown, the skin-engaging surface 34 can be made of a different material than the sidewall(s) 36.

[0023] The sidewall(s) 36 extend from skin-engaging surface 34 to create a cavity 40. As shown, for example, in FIGS. 1-1C, the sidewall(s) 36 can extend generally at a right angle to the skin-engaging surface 34, but one of skill in the art recognizes that the present invention is not so limited. For example, the skin-engaging surface 34 could gently transition into the sidewall(s) 36 via a smooth curve so that the edge of the lubrication box 108 gently flattens to the user's skin during normal shaving. The sidewall(s) 36 can be of any suitable height, depending on the needs and wants of the designer. As shown in FIGS. 2 and 3, the sidewall(s) 36 are approximately 4mm in height, creating a cavity 40 that has a volume of approximately 480mm³, not including the volume of the at least two holes 38.

[0024] A first layer of shaving aid 50 is ultrasonically compressed into the first portion 28 of the lubrication box 108 such that the first layer of shaving aid 50 is compacted in at least a portion of the cavity 40 and, preferably, compacted such that a portion of the first layer of shaving aid 50 substantially fills at least one of the holes 38. Even more preferably, the first layer of shaving aid 50 substantially fills all of the holes 38. And, most preferably, the first layer of shaving aid 50 completely fills all of the holes 38. The shaving aid 30 is generally added in solid form (e.g., in a powder) and ultrasonically compressed to form a unitary solid body that generally matches the interior shape of the cavity 40 and holes 38. The compaction of the material further frictionally locks the first layer of shaving aid 50 into the desired position (i.e., in at least a portion the holes 38 and the portion of the cavity 40 adjacent the holes 38).

[0025] The shaving aid 30, preferably, includes 100% water soluble shaving aid materials, although water in-

soluble shaving aid materials are acceptable. For example, the shaving aid 30 can include any substance that enhances shaving performance. It may, for example, improve shaving comfort (e.g., by lubricating the skin, improve shaving efficiency, condition the beard, or condition the skin). Examples of appropriate shaving aids 30 include lubricous water-soluble polymers such as polyethylene oxide, polyvinyl pyrrolidone, polyacrylamide, hydroxyethyl cellulose, hydroxypropyl cellulose, polyvinyl imidazoline, polyhydroxyethylmethacrylate, polyvinyl alcohol. The preferred lubricous water-soluble polymer is polyethylene oxide. The more preferred polyethylene oxides will preferably have molecular weights of about 100,000 to 8 million, most preferably about 300,000 to 5 million. The most preferred polyethylene oxide comprises a blend of about 40 to 80% of polyethylene oxide having an average molecular weight of about 5 million and about 20 to 60% of polyethylene oxide having an average molecular weight of about 300,000.

[0026] The polyethylene oxide blend may also advantageously contain plasticizers. The use of the plasticizers allows the utilization of substantially lower temperatures during the time of processing to produce a flowability of the polyethylene oxide during ultrasonic compressing without substantially reducing its molecular weight. Preferred plasticizers are polyethylene glycol particularly with molecular weight between 400 and 20,000, water soluble polypropylene glycol particularly with molecular weight between 400 and 4,000, water-soluble copolymers of ethylene and propylene oxide, water-soluble alkyl phenol ethoxylates, glycerine, sorbitol and water. Particularly preferred plasticizers are propylene glycol and octyl phenol ethoxylate with 9 moles of ethylene oxide. Additional ingredients to the shaving aid 30 can include:

- A. A lubricating agent for reducing the frictional forces between the skin engaging elements and the skin, e.g., a micro-encapsulated silicone oil.
- B. Any additional agent which reduces the drag between the skin engaging elements and the shaver's face, e.g., a non-ionic polyacrylamide; and/or a natural polysaccharide derived from plant materials such as "guar gum."
- C. An agent which modifies the chemical structure of the hair to allow the at least one razor blade 106 to pass through the whiskers very easily, e.g., a depilatory agent is one example.
- D. A cleaning agent which allows the whisker and skin debris to be washed more easily from the skin engaging elements during shaving, e.g., a silicon polyethylene oxide block copolymer and detergent such as sodium lauryl sulphate.
- E. A medicinal agent for killing bacteria, or repairing skin damage and abrasions.
- F. A cosmetic agent for softening, smoothing, conditioning or improving the skin.
- G. A blood coagulant for the suppression of bleeding that occurs from nicks and cuts.

H. An astringent for constricting blood vessels thereby stemming the flow of bodily fluids such as lymph, which can exude from skin which has been irritated during shaving.

5

10

15

20

25

30

35

40

45

50

55

[0027] Additional layer(s) of shaving aid 54 can be added to the cavity 40 of the first portion of the lubrication box 28. In some embodiments, a designer may choose to have the subsequent layers 54 included in the lubrication box 102 be generally the same, if not identical, in amount and/or chemical composition to previous layer(s). However, a designer may prefer that a subsequent layer 54 be different than a previous layer in one or more aspects. For example, a subsequent layer 54 may be designed such that it is a different in amount, chemical composition, and/or color than a previous layer. Such a change could be used to provide a varied shaving benefit to the user and/or notify a user that, for example, the lubrication box 108 has almost reached its usable lifespan.

[0028] The second portion 32 of the lubrication box 108, as shown in FIGS. 5, 5A and 5B, is affixed to the first portion 28 of the lubrication box 108, substantially encasing the shaving aid 30 therein. The second portion 32 of the lubrication box 108 can be of any suitable shape and size, provided that the second portion 32 of the lubrication box 108 substantially covers the open end of the cavity 40 formed by the sidewall(s) 36 and skin-engaging surface 34 of the first portion 28 of the lubrication box 108. In addition, the second portion 32 of the lubrication box 108, preferably, is shaped such that a gap 42 exists between the shaving aid 30 and the inner surface 44 of the second portion 32 of the lubrication box 108. The air gap 42 provides space for the shaving aid 30 to expand when wetted. The expansion of the shaving aid 30 can, otherwise, cause an excessive amount of shaving aid 30 to exit through the at least two holes 38 and/or cause the first 28 and/or second portion 32 of the lubrication box 108 to separate from one another, deform and/or crack.

[0029] The second portion 32 of the lubrication box 108 can be made from any material; however, it is often preferable for the material to be made of plastic, metal or rubber. The second portion 32 of the lubrication box 108 can be attached to the first portion 28 of the lubrication box 108 in any suitable manner. The most suitable manner for attaching the two portions 28,32 of the lubrication box 108 often depends on the type of material used. For example, ultrasonically welding the two portions 28,32 of the lubrication box 108 together has been shown to have particular utility when, for example, the two portions 28,32 of the lubrication box 108 are made from plastic materials. However, the present invention is not so limited, and the two portions 28,32 of the lubrication box 108 can be glued or otherwise bonded together. In addition, in some embodiments, a physical connection (e.g., male/female connectors, press fit) is suitable.

[0030] The size of the gap 42 between the shaving aid

30 and the second portion 32 of the lubrication box 108 depends on a number of factors, including, but not limited to, the size of the lubrication box 108, and the amount of shaving aid 30 added to the cavity 40. In some cases, a small hole 55 through the first portion 28 or second portions 32 of the lubrication box 108 (see e.g., Fig. 5B) can assist to alleviate the build-up of excessive pressure inside the lubrication box 108 during normal use.

[0031] In some embodiments, and specifically referring to Fig. 5A, the second portion 32 of the lubrication box 108 can include one or more additional support features 46 that extend into the cavity 40 that are in close proximity to, or in direct contact with, the shaving aid 30. During use, as water mixes with the shaving aid 30, a portion of the shaving aid 30 begins to dissolve. As more and more shaving aid 30 dissolves, the compacted shaving aid 30 will often, undesirably, become dislodged from its position in the cavity 40. The support feature(s) 46 tend to hold the shaving aid 30 forwards in the cavity 40 in close proximity to the at least two holes 38, where the shaving aid 30 is most likely to mix with water and provide the maximum shaving benefit to the skin during normal use. The support features 46 can be located adjacent the side wall(s) 36, and/or away from the side wall(s) 36 and towards the center of the cavity 40. Preferably, the support feature(s) 46 provide support for the shaving aid 30 at several locations within the cavity 40.

[0032] One method of making the shaving cartridge 102 of the present invention includes, first, providing a first portion 28 of the lubrication box 108. As noted above, the first portion 28 of the lubrication box 108 can be made of any suitable material by any known means (e.g., molding a plastic first portion of the lubrication box 28). The first portion 28 of the lubrication box 108 is placed in a support nest 62 and a first amount of shaving aid 30 is distributed in the cavity 40.

[0033] Once the first amount of shaving aid 30 is distributed in the cavity 40 of the first portion 28 of the lubrication box 108, a piston 48 then repeatedly applies pressure, ultrasonically compacting the shaving aid 30, forming a first layer of shaving aid 50. For example, in an embodiment using 25-45mg polyethylene oxide with a Vitamin E additive, the piston applies approximately 445 N - 627 N (100-150 lbs) of force, 15-20J of energy provided by an ultrasonic source for approximately .1 to .2 seconds hold time during a single cycle. The actual number of times, length of time, amount of energy and/or amount of force applied may vary depending on numerous factors, including but not limited to the amount of shaving aid being compacted, the type of shaving aid being compacted, the actual size and shape of the lubrication box, and the desired level of compaction. The ultrasonic compaction process enables good compaction of materials while not subjecting active ingredients to conditions (e.g., high temperatures and/or pressures for extended periods of time) that tend to degrade the active ingredients in the shaving aid 30, thus hindering the ability of the materials to provide the intended shaving benefit.

As a benefit of the ultrasonic compaction process, a high percentage of active ingredients in the shaving aid 30 survive and are available during normal use to provide the anticipated benefit.

[0034] Once the first layer of shaving aid 50 is formed, or compacted, a second amount of shaving aid 30 is, optionally, distributed into the cavity 40 of the first portion of the lubrication box 28. The above ultrasonic compaction process is repeated.

[0035] Optionally, once the second layer of shaving aid 52 is compacted, a third, fourth, or more layers of additional amounts of shaving aid 54 can be distributed and compacted within the cavity 40 of the lubrication box 108. During the compaction process, due to the speed of the piston 48, and the gap between the side edge of the piston 48 and the inner side of the side walls 36, shaving aid 30 particles are often stirred during the compaction process. A vacuum (not shown) can be provided to remove any portion of shaving aid 30 that is not compacted during the ultrasonic compaction process.

[0036] Once the shaving aid layer(s) 50, 52, 54 are compacted within the first portion 28 of the lubrication box 108, the second portion 32 of the lubrication box 108 is placed on the opening of the cavity 40 of the first portion 28 of the lubrication box 108 and affixed. The lubrication box 108 is then affixed, directly or indirectly, to the frame 104 of the shaving cartridge 102 such that the skin-engaging elements are, or can be, in contact with the user's skin during normal shaving. In some embodiments, the lubrication box 108 is removable and replaceable on the frame 104 of the shaving cartridge 102.

[0037] In use, the shaving cartridge 102 is affixed to a handle 10 and a user wets the shaving cartridge 102. The water enters the at least two holes 38 of the lubrication box 108 and mixes with the shaving aid 30. The shaving aid 30, when wet, typically expands, filling at least a portion of the gap 42 within the lubrication box 108. Simultaneously, a portion of the shaving aid 30 dissolves in the water, and exits through the at least two holes 38. The shaving cartridge 102 is then put into contact with the user and drawn across the skin. The blade(s) 106 of the shaving cartridge 102 shave the hair as the now-dissolved shaving aid 102 is distributed on the skin, providing a benefit.

[0038] Only some embodiments of the present invention have been illustrated in the drawings, but it should be pointed out that many other modifications are conceivable within the scope of the following claims.

Claims

1. A lubrication box, comprising:

- a first portion (28) of the lubrication box (108), the first portion (28) having a skin-engaging surface (34) and at least one sidewall (36), the skin-engaging surface (34) and the at least one side

walls (36) forming a cavity (40),
 - at least two holes (38) extending through the skin-engaging surface (34) of the first portion (28),
 - a shaving aid material (30,50,52,54) disposed into the cavity (40), the shaving aid material (30) at least partially filling at least one of the holes (38) in the skin-engaging surface (34) and at least a portion of the cavity (40), and
 - a second portion (32) of the lubrication box (108), the second portion (32) being attached to the first portion (28) such that the cavity (40) is substantially closed,

characterized in that

- the shaving aid material (30,50,52,54) is ultrasonically compressed into the cavity (40), and
 - a gap (42) exists in the cavity (40) between the shaving aid material (30,50,52,54) and the second portion (32) of the lubrication box (108) to permit the shaving aid material (30,50,52,54) to expand during normal use.

2. The lubrication box of claim 1, wherein the skin-engaging surface (34) is generally rectangular.
3. The lubrication box of claim 1 or 2, wherein the skin-engaging surface (34) includes at least five holes (38).
4. The lubrication box of any one of claims 1 to 3, wherein the skin-engaging surface (34) includes at least ten holes (38).
5. The lubrication box of claim 4, wherein the skin-engaging surface (34) includes at least fifteen holes (38).
6. The lubrication box of any one of claims 1 to 3, wherein holes (38) are aligned in a single row.
7. The lubrication box of any one of claims 1 to 6, wherein the shaving aid material (30,50,52,54) includes a first layer (50) of shaving aid material (30,50,52,54) that at least partially fills at least one hole (38), as well as at least a portion of the cavity (40) of the first portion (28) of the lubrication box (108).
8. The lubrication box of claim 7, wherein the shaving aid material (30,50,52,54) includes a second layer (52) of shaving aid material (30,50,52,54) that is located in the cavity (40) of first portion (28) of the lubrication box (108).
9. The lubrication box of claim 8, wherein the second layer (52) is directly adjacent the first layer (50) of shaving aid material (30,50,52,54).

5
10
15
20
25
30
35
40
45
50
55

10. The lubrication box of claim 7 or 8, wherein the first and second layers (50,52) of shaving aid material (30,50,52,54) have substantially the same chemical composition or different chemical compositions.
11. The lubrication box of any one of claims 8 to 10, wherein the first and second layers (50,52) of shaving aid material (30,50,52,54) are provided in substantially the same amounts or in unequal amounts.
12. The lubrication box of any one of claims 8 to 11, wherein the shaving aid material (30,50,52,54) includes a third layer (54) of shaving aid material (30,50,52,54) that is located in the cavity (40) of first portion (28) of the lubrication box (108).
13. The lubrication box of claim 12, wherein the third layer (54) of shaving aid material (30,50,52,54) is directly adjacent the second layer (52) of shaving aid material (30,50,52,54).
14. The lubrication box of any one of claims 8 to 13, wherein at least one layer of shaving aid material (30,50,52,54) is a different color than at least one other layer of shaving aid material (30,50,52,54).
15. The lubrication box of any one of claims 1 to 14, wherein the second portion (32) includes at least one support structure that is in close proximity to or in direct contact with the shaving aid material (30,50,52,54).
16. A method of making a lubrication box, the method comprising the steps of:
 - providing a first portion (28) of the lubrication box (108), the first portion (28) having a skin-engaging surface (34) and at least one sidewall (36) that form a cavity (40), the skin-engaging surface (34) having at least two holes (38) there-through,
 - distributing a first amount of shaving aid material (30,50,52,54) into the cavity (40) of the first portion (28) of the lubrication box (108),
 - ultrasonically compressing the first amount shaving aid material (30,50,52,54) to form a first layer (50) of shaving aid material (30,50,52,54) such that the first layer (50) fills at least a portion of one of the holes (38),
 - providing a second portion (32) of the lubrication box (108) that covers an open end of the cavity (40) of the first portion (28) such that a gap (42) remains between the ultrasonically compressed shaving aid material (30,50,52,54) and an inner surface of the second portion (32) of the lubrication box (108), and
 - affixing the second portion (32) of the lubrication box (108) to the first portion (28) of the lu-

brication box (108).

17. The method of making a lubrication box of claim 16, wherein the step of providing a first portion (28) of the lubrication box (108) includes molding the first portion (28) of a polymeric material. 5
18. The method of making a lubrication box of claim 16, wherein the method includes additional steps of distributing a second amount of shaving aid material (30,50,52,54) into the cavity (40) of the first portion (28) of the lubrication box (108) onto the ultrasonically compressed first layer (50), then ultrasonically compressing the second amount shaving aid material (30,50,52,54) to form a second layer (52) of shaving aid material (30,50,52,54) that is adjacent to the first layer (50) of shaving aid material (30,50,52,54) in the cavity (40) such that the second layer (52) fills at least a portion of the cavity (40). 10
19. The method of making a lubrication box of claim 18, wherein the method includes additional steps of distributing a third amount of shaving aid material (30,50,52,54) into the cavity (40) of the first portion (28) of the lubrication box (108) onto the ultrasonically compressed second layer (52), then ultrasonically compressing the third amount shaving aid material (30,50,52,54) to form a third layer (54) of shaving aid material (30,50,52,54) that is adjacent to the second layer (52) of shaving aid material (30,50,52,54) in the cavity (40) such that the third layer (54) fills at least a portion of the cavity (40). 15 20 25 30

Patentansprüche

1. Gleitmittelbox mit:

- einem ersten Abschnitt (28) der Gleitmittelbox (108), wobei der erste Abschnitt (28) eine Hautanlagefläche (34) und mindestens eine Seitenwand (36) aufweist, wobei die Hautanlagefläche (34) und die mindestens eine Seitenwand (36) einen Hohlraum (40) bilden, 40
- mindestens zwei Löchern (38), die sich durch die Hautanlagefläche (34) des ersten Abschnitts (28) erstrecken, 45
- einem Rasierhilfsmaterial (30,50,52,54), das in dem Hohlraum (40) angeordnet ist, wobei das Rasierhilfsmaterial (30) mindestens eines der Löcher (38) in der Hautanlagefläche (34) und mindestens einen Abschnitt des Hohlraums (40) mindestens teilweise ausfüllen, und 50
- einem zweiten Abschnitt (32) der Gleitmittelbox (108), wobei der zweite Abschnitt (32) an dem ersten Abschnitt (28) derart befestigt ist, dass der Hohlraum (40) im Wesentlichen geschlossen ist, 55

dadurch gekennzeichnet, dass

- das Rasierhilfsmaterial (30,50,52, 54) mittels Ultraschall in den Hohlraum (40) gepresst ist, 5
 - in dem Hohlraum (40) zwischen dem Rasierhilfsmaterial (30,50,52, 54) und dem zweiten Abschnitt (32) der Gleitmittelbox (108) ein Spalt (42) existiert, um dem Rasierhilfsmaterial (30,50,52,54) zu erlauben, sich während der normalen Verwendung auszudehnen. 10
2. Gleitmittelbox nach Anspruch 1, bei der die Hautanlagefläche (34) im Wesentlichen rechteckig ist. 15
 3. Gleitmittelbox nach Anspruch 1 oder 2, bei der die Hautanlagefläche (34) mindestens fünf Löcher (38) aufweist. 20
 4. Gleitmittelbox nach einem der Ansprüche 1 bis 3, bei der die Hautanlagefläche (34) mindestens zehn Löcher (38) aufweist. 25
 5. Gleitmittelbox nach Anspruch 4, bei der die Hautanlagefläche (34) mindestens fünfzehn Löcher (38) aufweist. 30
 6. Gleitmittelbox nach einem der Ansprüche 1 bis 3, bei der Löcher (38) in einer einzelnen Reihe ausgerichtet sind. 35
 7. Gleitmittelbox nach einem der Ansprüche 1 bis 6, bei der das Rasierhilfsmaterial (30,50,52,54) eine erste Lage (50) von Rasierhilfsmaterial (30,50,52,54) aufweist, die mindestens ein Loch (38) sowie mindestens einen Abschnitt des Hohlraums (40) des ersten Abschnitts (28) der Gleitmittelbox (108) mindestens teilweise ausfüllt. 40
 8. Gleitmittelbox nach einem der Anspruch 7, bei der das Rasierhilfsmaterial (30,50,52,54) eine zweite Lage (52) von Rasierhilfsmaterial (30,50,52, 54) aufweist, die in dem Hohlraum (40) des ersten Abschnitts (28) der Gleitmittelbox (108) angeordnet ist. 45
 9. Gleitmittelbox nach einem der Anspruch 8, bei der die zweite Lage (52) direkt an die erste Lage (50) von Rasierhilfsmaterial (30,50,52,54) angrenzt. 50
 10. Gleitmittelbox nach einem der Anspruch 7 oder 8, bei der die ersten und zweiten Lagen (50,52) von Rasierhilfsmaterial (30,50,52,54) im Wesentlichen die gleiche chemische Zusammensetzung oder verschiedene chemische Zusammensetzungen aufweisen. 55
 11. Gleitmittelbox nach einem der Ansprüche 8 bis 10, bei der die ersten und zweiten Lagen (50,52) von Rasierhilfsmaterial (30,50,52,54) in im Wesentli-

chen gleichen Mengen oder in unterschiedlichen Mengen vorgesehen sind.

12. Gleitmittelbox nach einem der Ansprüche 8 bis 11, bei der das Rasierhilfsmaterial (30,50,52,54) eine dritte Lage (54) von Rasierhilfsmaterial (30,50,52,54) aufweist, die in dem Hohlraum (40) des ersten Abschnitts (28) der Gleitmittelbox (108) angeordnet ist. 5
13. Gleitmittelbox nach Anspruch 12, bei der die dritte Lage (54) von Rasierhilfsmaterial (30,50,52,54) direkt an die zweite Lage (52) von Rasierhilfsmaterial (30,50,52,54) angrenzt. 10
14. Gleitmittelbox nach einem der Ansprüche 8 bis 13, bei der mindestens eine Lage von Rasierhilfsmaterial (30,50,52,54) eine unterschiedliche Farbe hat als mindestens eine weitere Lage von Rasierhilfsmaterial (30,50,52,54). 15
15. Gleitmittelbox nach einem der Ansprüche 1 bis 14, bei der der zweite Abschnitt (32) mindestens eine Haltestruktur aufweist, die in enger Nähe zu oder in direktem Kontakt mit dem Rasierhilfsmaterial (30,50,52,54) angeordnet ist. 20
16. Verfahren zum Herstellen einer Gleitmittelbox, wobei das Verfahren folgende Schritte aufweist: 25
- Erzeugen eines ersten Abschnitts (28) der Gleitmittelbox (108), wobei der erste Abschnitt (28) eine Hautanlagefläche (34) und mindestens eine Seitenwand (36) aufweist, die einen Hohlraum (40) bilden, wobei die Hautanlagefläche (34) mindestens zwei durch sie hindurch verlaufende Löcher (38) aufweist, 30
 - Verteilen einer ersten Menge von Rasierhilfsmaterial (30,50,52,54) in dem Hohlraum (40) des ersten Abschnitts (28) der Gleitmittelbox (108), 35
 - Ultraschall-Verdichten der ersten Menge von Rasierhilfsmaterial (30,50,52,54) zur Bildung einer ersten Lage (50) von Rasierhilfsmaterial (30,50,52,54) derart, dass die erste Lage (50) mindestens einen Abschnitt eines der Löcher (38) ausfüllt, 40
 - Erzeugen eines zweiten Abschnitts (32) der Gleitmittelbox (108), der ein offenes Ende des Hohlraums (40) des ersten Abschnitts (28) derart bedeckt, dass zwischen dem ultraschallverdichteten Rasierhilfsmaterial (30,50,52,54) und einer Innenfläche des zweiten Abschnitts (32) der Gleitmittelbox (108) ein Spalt (42) verbleibt, und 45
 - Befestigen des zweiten Abschnitts (32) der Gleitmittelbox (108) an dem ersten Abschnitt (28) der Gleitmittelbox (108). 50

17. Verfahren zum Herstellen einer Gleitmittelbox nach Anspruch 16, bei dem der Schritt des Erzeugens eines ersten Abschnitts (28) der Gleitmittelbox (108) das Formen des ersten Abschnitts (28) aus einem Polymermaterial umfasst. 5
18. Verfahren zum Herstellen einer Gleitmittelbox nach Anspruch 16, wobei das Verfahren die zusätzlichen Schritte des Verteilens einer zweiten Menge von Rasierhilfsmaterial (30,50,52,54) in dem Hohlraum (40) des ersten Abschnitts (28) der Gleitmittelbox (108) auf die ultraschallverdichtete erste Lage (50) und des anschließenden Ultraschallverdichtens der zweiten Menge von Rasierhilfsmaterial (30,50,52,54) zur Bildung einer zweiten Lage (52) von Rasierhilfsmaterial (30,50,52,54) umfasst, die derart an die erste Lage (50) von Rasierhilfsmaterial (30,50,52,54) in dem Hohlraum (40) angrenzt, dass die zweite Lage (52) mindestens einen Abschnitt des Hohlraums (40) ausfüllt. 10
19. Verfahren zum Herstellen einer Gleitmittelbox nach Anspruch 18, wobei das Verfahren die zusätzlichen Schritte des Verteilens einer dritten Menge von Rasierhilfsmaterial (30,50,52,54) in dem Hohlraum (40) des ersten Abschnitts (28) der Gleitmittelbox (108) auf die ultraschallverdichtete zweite Lage (52) und des anschließenden Ultraschallverdichtens der dritten Menge von Rasierhilfsmaterial (30,50,52,54) zur Bildung einer dritten Lage (54) von Rasierhilfsmaterial (30,50,52,54) umfasst, die derart an die zweite Lage (52) von Rasierhilfsmaterial (30,50,52,54) in dem Hohlraum (40) angrenzt, dass die dritte Lage (54) mindestens einen Abschnitt des Hohlraums (40) ausfüllt. 15

Revendications

1. Boîte de lubrification, comprenant : 40
- une première partie (28) de la boîte de lubrification (108), la première partie (28) ayant une surface de contact avec la peau (34) et au moins une paroi latérale (36), la surface de contact avec la peau (34) et l'au moins une paroi latérale (36) formant une cavité (40), 45
 - au moins deux trous (38) s'étendant à travers la surface de contact avec la peau (34) de la première partie (28), 50
 - une matière d'aide au rasage (30, 50, 52, 54) disposée dans la cavité (40), la matière d'aide au rasage (30) remplissant au moins partiellement au moins un des trous (38) de la surface de contact avec la peau (34) et au moins une partie de la cavité (40), et 55
 - une seconde partie (32) de la boîte de lubrification (108), la seconde partie (32) étant atta-

chée à la première partie (28) de manière que la cavité (40) soit sensiblement fermée,

caractérisée en ce que

- la matière d'aide au rasage (30, 50, 52, 54) est comprimée dans la cavité (40) au moyen d'ultrasons, un espace libre (42) existe dans la cavité (40) entre la matière d'aide au rasage (30, 50, 52, 54) et la seconde partie (32) de la boîte de lubrification (108) pour permettre à la matière d'aide au rasage (30, 50, 52, 54) de se dilater pendant l'utilisation normale.
2. Boîte de lubrification selon la revendication 1, dans laquelle ladite surface de contact avec la peau (34) est de forme générale rectangulaire.
 3. Boîte de lubrification selon la revendication 1 ou 2, dans laquelle la surface de contact avec la peau (34) présente au moins cinq trous (38).
 4. Boîte de lubrification selon une quelconque des revendications 1 à 3, dans laquelle la surface de contact avec la peau (34) présente au moins dix trous (38).
 5. Boîte de lubrification selon la revendication 4, dans laquelle la surface de contact avec la peau (34) présente au moins quinze trous (38).
 6. Boîte de lubrification selon une quelconque des revendications 1 à 3, dans laquelle les trous (38) sont alignés en une seule rangée.
 7. Boîte de lubrification selon une quelconque des revendications 1 à 6, dans laquelle la matière d'aide au rasage (30, 50, 52, 54) comprend une première couche (50) de matière d'aide au rasage (30, 50, 52, 54) qui remplit au moins partiellement au moins un trou (38) ainsi qu'au moins une partie de la cavité (40) de la première partie (28) de la boîte de lubrification (108).
 8. Boîte de lubrification selon la revendication 7, dans laquelle la matière d'aide au rasage (30, 50, 52, 54) comprend une seconde couche (52) de matière d'aide au rasage (30, 50, 52, 54) qui est située dans la cavité (40) de la première partie (28) de la boîte de lubrification (108).
 9. Boîte de lubrification selon la revendication 8, dans laquelle la seconde couche (52) est directement adjacente à la première couche (50) de matière d'aide au rasage (30, 50, 52, 54).
 10. Boîte de lubrification selon la revendication 7 ou 8, dans laquelle les première et seconde couches (50, 52) de matière d'aide au rasage (30, 50, 52, 54) ont sensiblement la même composition chimique ou ont

des compositions chimiques différentes.

11. Boîte de lubrification selon une quelconque des revendications 8 à 10, dans laquelle les première et seconde couches (50, 52) de matière d'aide au rasage (30, 50, 52, 54) sont prévues en quantités sensiblement égales ou en quantités inégales.
12. Boîte de lubrification selon une quelconque des revendications 8 à 11, dans laquelle la matière d'aide au rasage (30, 50, 52, 54) comprend une troisième couche (54) qui est située dans la cavité (40) de la première partie (28) de la boîte de lubrification (108).
13. Boîte de lubrification selon la revendication 12, dans laquelle la troisième couche (54) de matière d'aide au rasage (30, 50, 52, 54) est directement adjacente à la seconde couche (52) de matière d'aide au rasage (30, 50, 52, 54).
14. Boîte de lubrification selon une quelconque des revendications 8 à 13, dans laquelle l'au moins une couche de matière d'aide au rasage (30, 50, 52, 54) est d'une couleur différente de celle d'au moins une autre couche de matière d'aide au rasage (30, 50, 52, 54).
15. Boîte de lubrification selon une quelconque des revendications 1 à 14, dans laquelle la seconde partie (32) comprend au moins une structure de support qui est à proximité immédiate de la matière d'aide au rasage (30, 50, 52, 54) ou en contact direct avec cette dernière.
16. Procédé de fabrication d'une boîte de lubrification, le procédé comprenant les étapes consistant à :
 - prévoir une première partie (28) de la boîte de lubrification (108), la première partie (28) ayant une surface de contact avec la peau (34) et au moins une paroi latérale (36) qui forment une cavité (40), la surface de contact avec la peau (34) étant traversée par au moins deux trous (38),
 - distribuer une première quantité de matière d'aide au rasage (30, 50, 52, 54) dans la cavité (40) de la première partie (28) de la boîte de lubrification (108),
 - comprimer la première quantité de matière d'aide au rasage (30, 50, 52, 54) au moyen d'ultrasons pour former une première couche (50) de matière d'aide au rasage (30, 50, 52, 54) de manière que la première couche (50) remplisse au moins une partie de l'un des trous (38),
 - prévoir une seconde partie (32) de la boîte de lubrification (108) qui recouvre une extrémité ouverte de la cavité (40) de la première partie (28) de manière qu'il subsiste un espace libre

(42) entre la matière d'aide au rasage (30, 50, 52, 54) comprimée au moyen d'ultrasons et une surface interne de la seconde partie (32) de la boîte de lubrification (108) et

- fixer la seconde partie (32) de la boîte de lubrification (108) à la première partie (28) de la boîte de lubrification (108). 5

17. Procédé de fabrication d'une boîte de lubrification selon la revendication 16, dans lequel l'étape consistant à prévoir une première partie (28) de la boîte de lubrification (108) consiste à mouler la première partie (28) en une matière polymère. 10

18. Procédé de fabrication d'une boîte de lubrification selon la revendication 16, dans lequel le procédé comprend des étapes additionnelles consistant à distribuer une seconde quantité de matière d'aide au rasage (30, 50, 52, 54) dans la cavité (40) de la première partie (28) de la boîte de lubrification (108) sur la première couche (50) comprimée au moyen d'ultrasons, puis comprimer la seconde quantité de matière d'aide au rasage (30, 50, 52, 54) au moyen d'ultrasons pour former une seconde couche (52) de matière d'aide au rasage (30, 50, 52, 54) qui est adjacente à la première couche (50) de matière d'aide au rasage (30, 50, 52, 54) dans la cavité (40) de manière que la seconde couche (52) remplisse au moins une partie de la cavité (40). 15
20
25

19. Procédé de fabrication d'une boîte de lubrification selon la revendication 18, dans lequel le procédé comprend des étapes additionnelles consistant à distribuer une troisième quantité de matière d'aide au rasage (30, 50, 52, 54) dans la cavité (40) de la première partie (28) de la boîte de lubrification (108) sur la seconde couche (52) comprimée au moyen d'ultrasons, puis comprimer la troisième quantité de matière d'aide au rasage (30, 50, 52, 54) au moyen d'ultrasons pour former une troisième couche (54) de matière d'aide au rasage (30, 50, 52, 54) qui est adjacente à la seconde couche (52) de matière d'aide au rasage (30, 50, 52, 54) dans la cavité (40) de manière que la troisième couche (54) remplisse au moins une partie de la cavité (40). 30
35
40
45

50

55

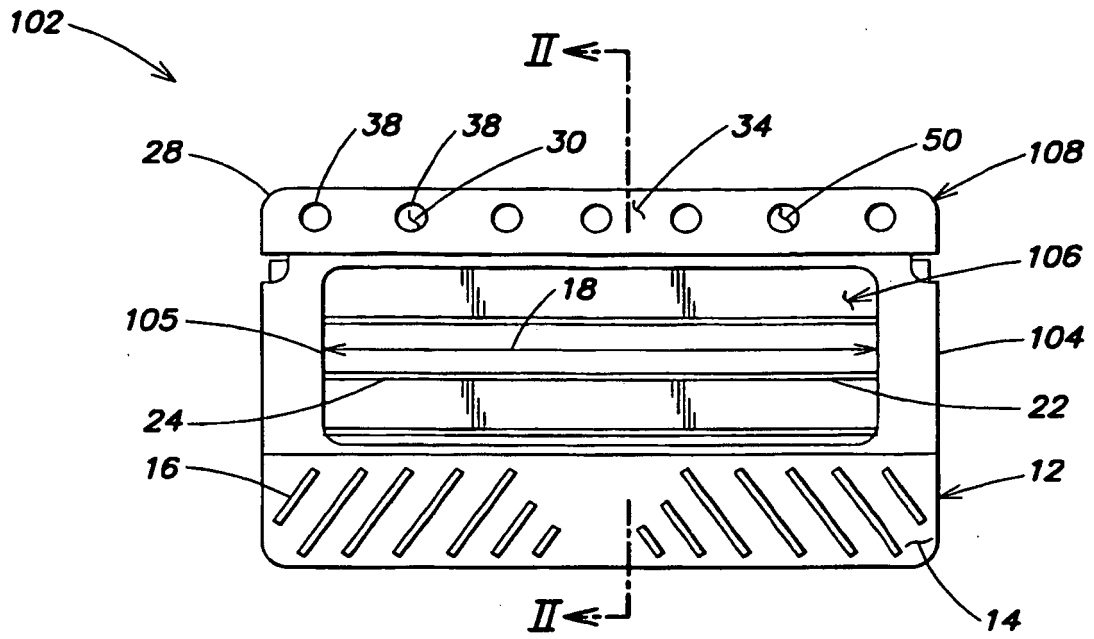

FIG. 1

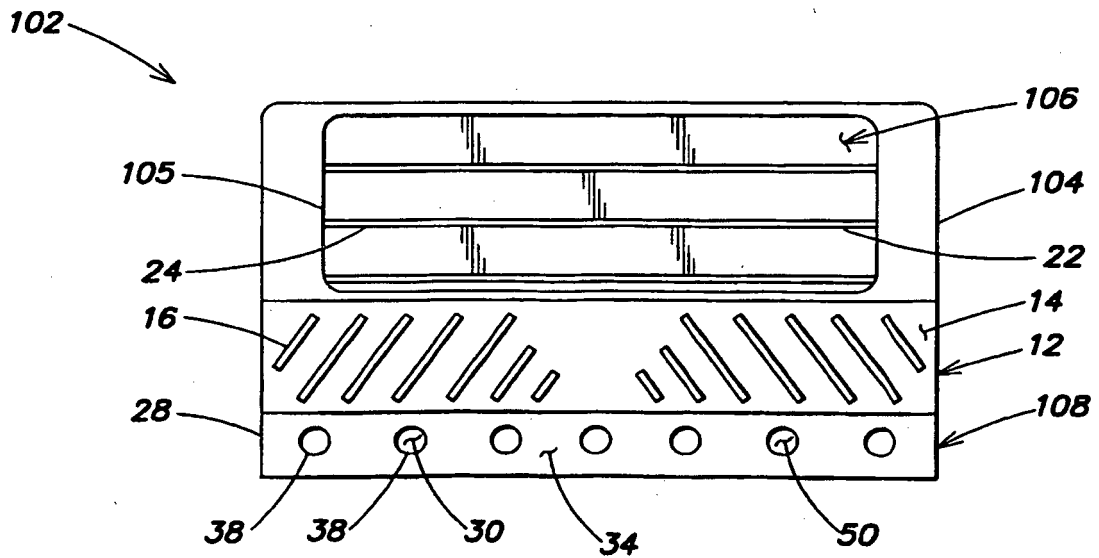

FIG. 1A

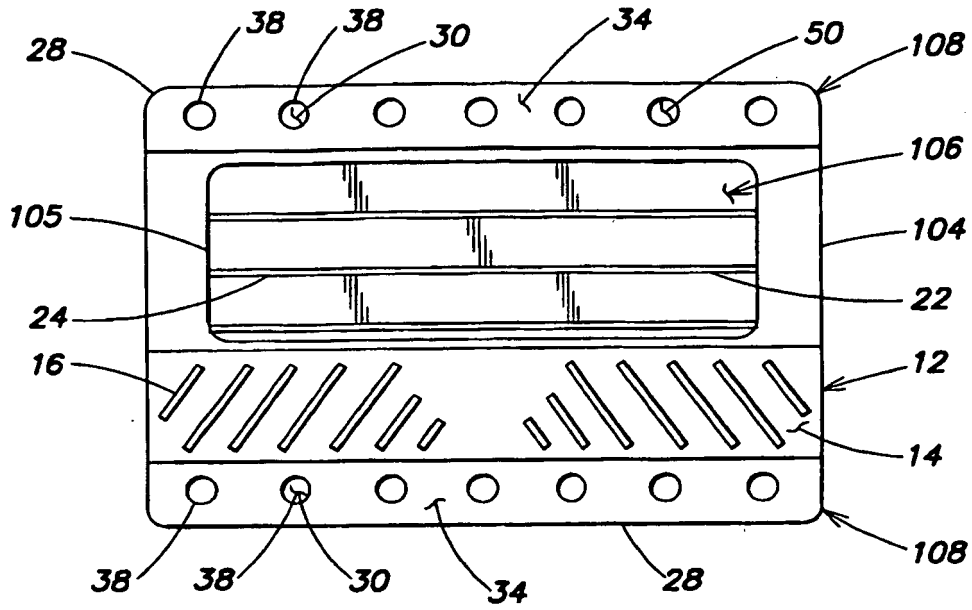

FIG. 1B

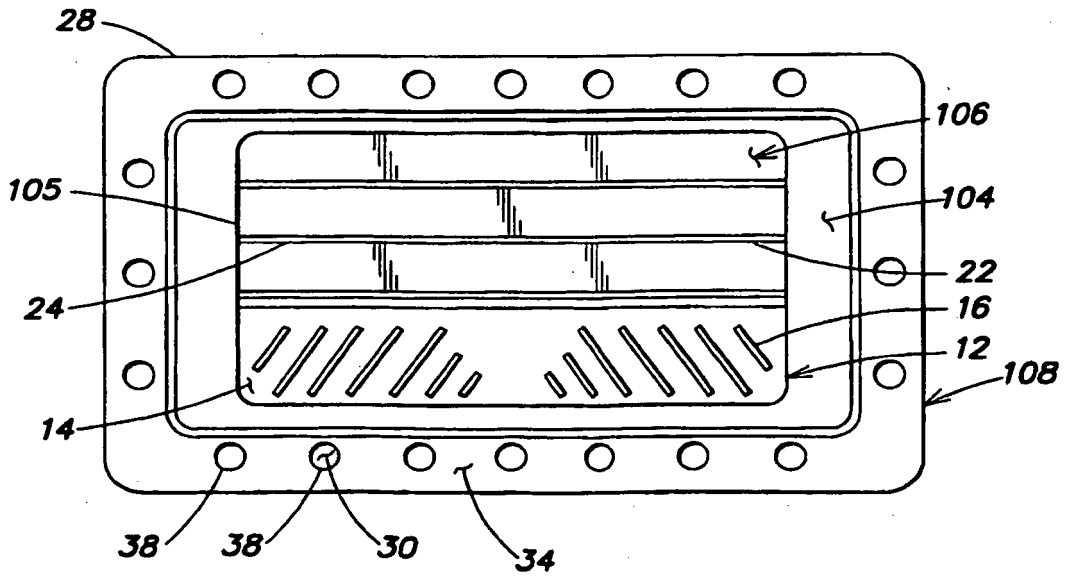

FIG. 1C

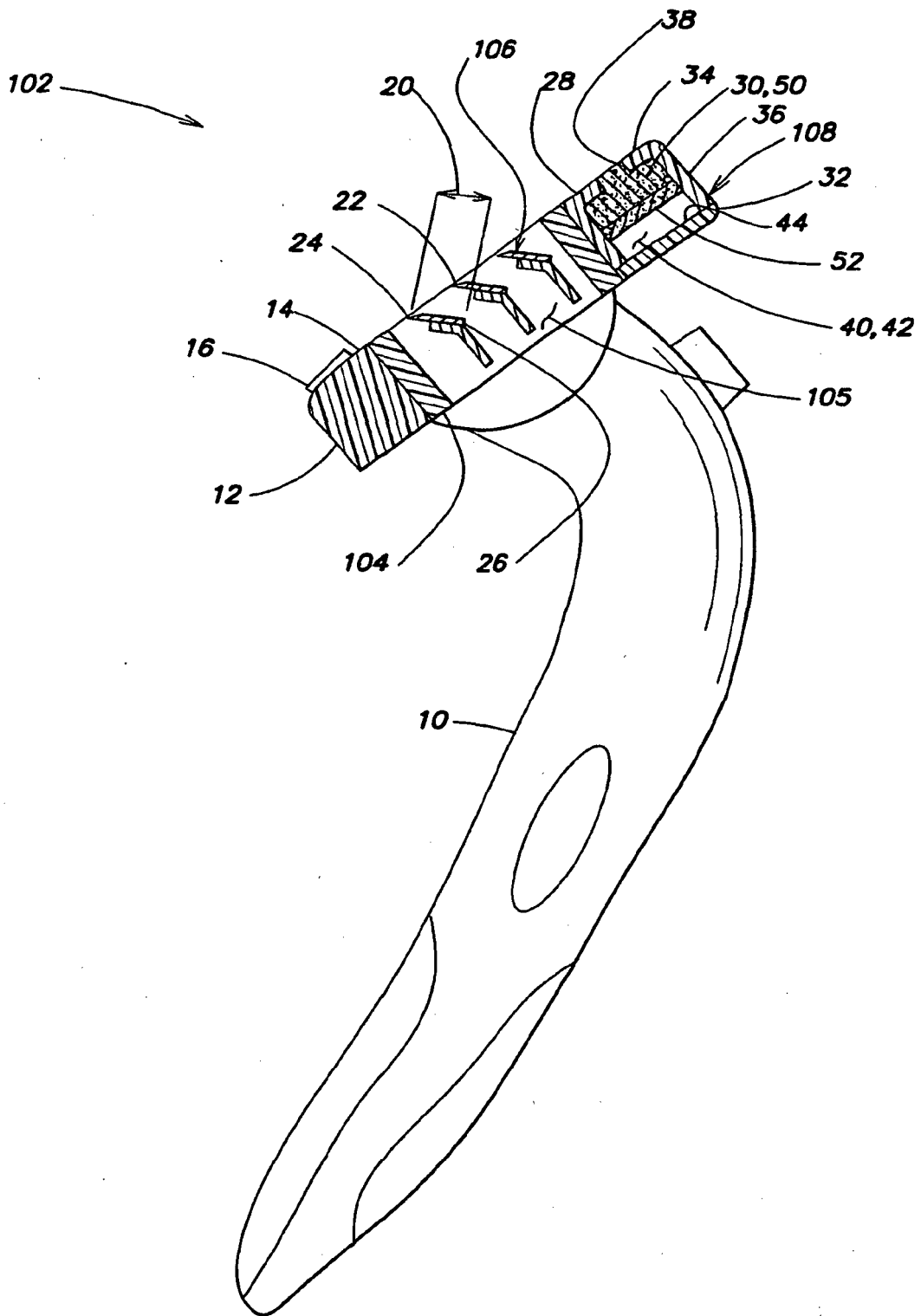

FIG. 2

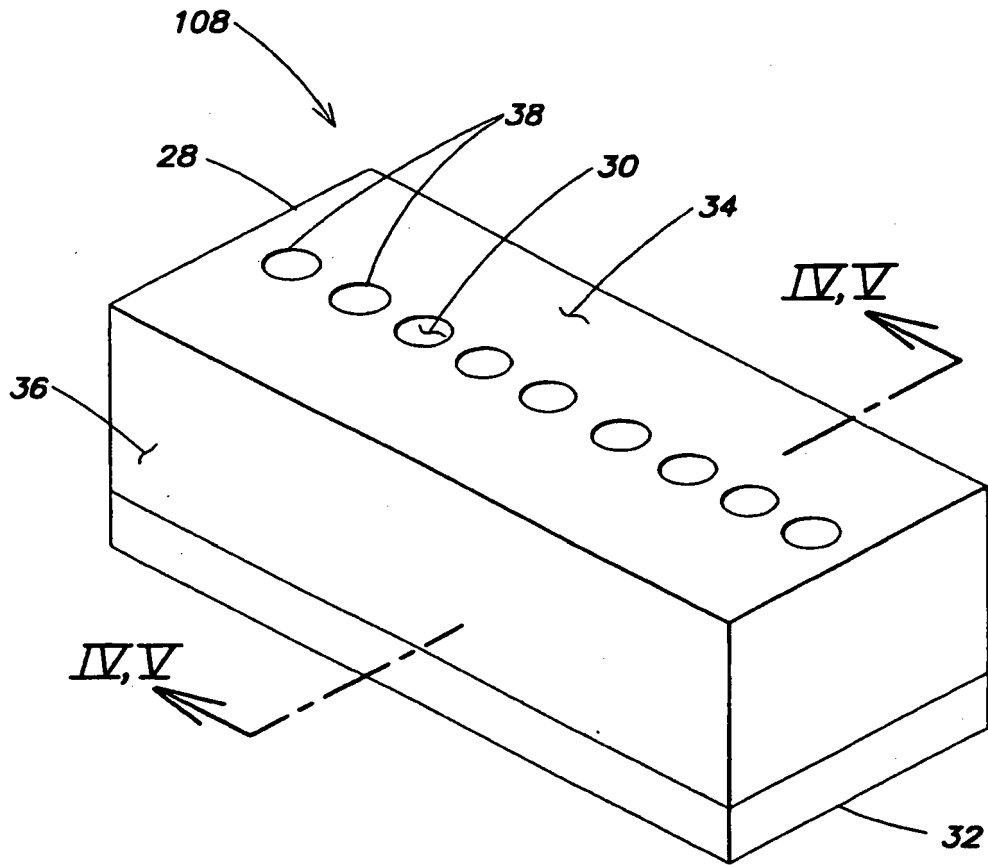

FIG. 3

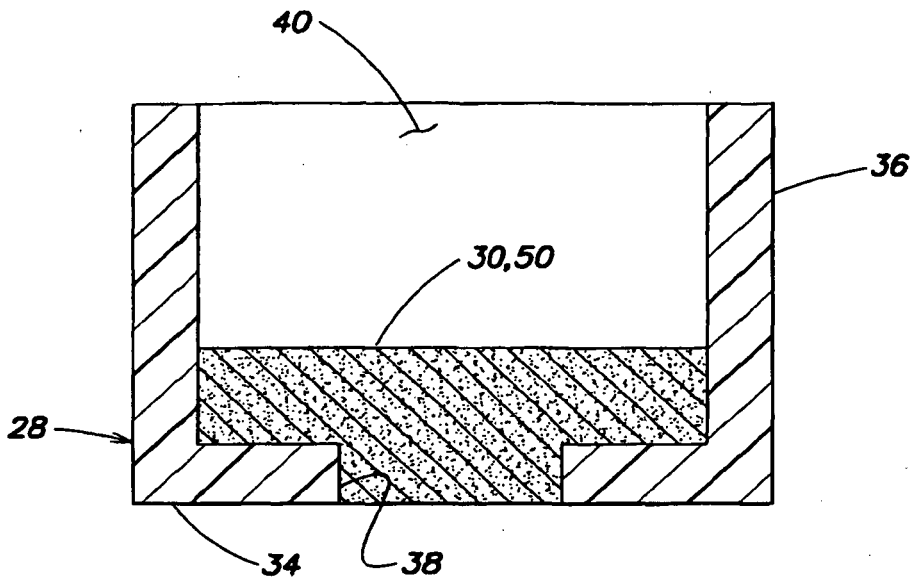

FIG. 4

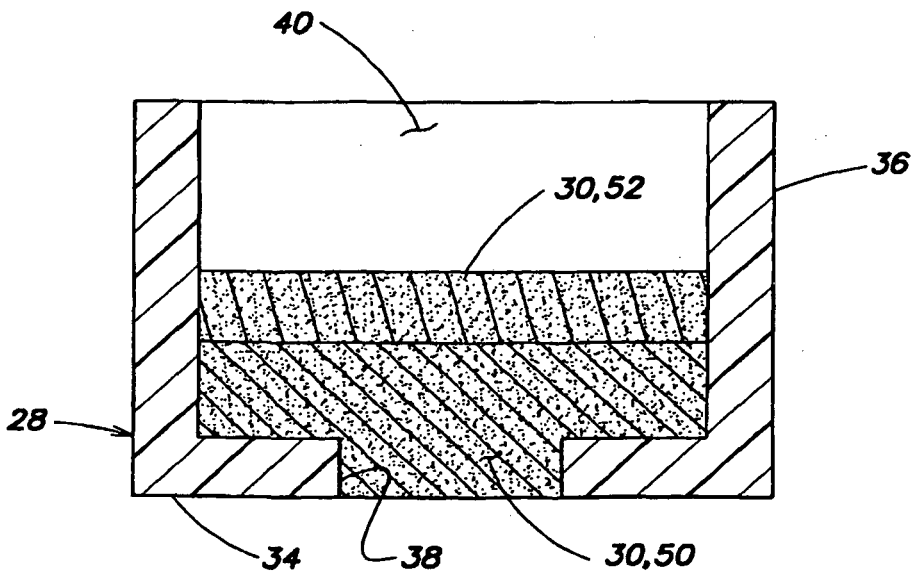

FIG. 4A

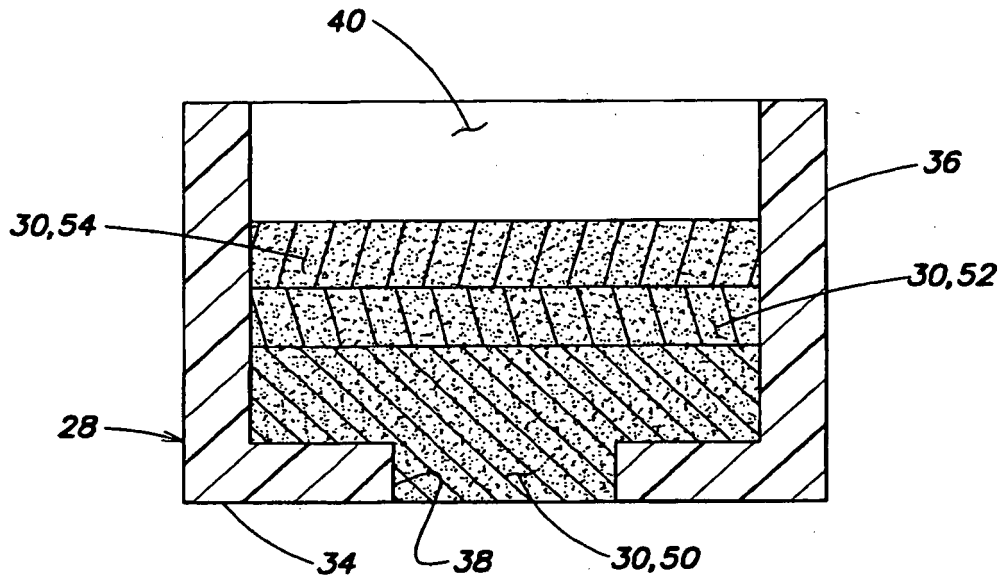

FIG. 4B

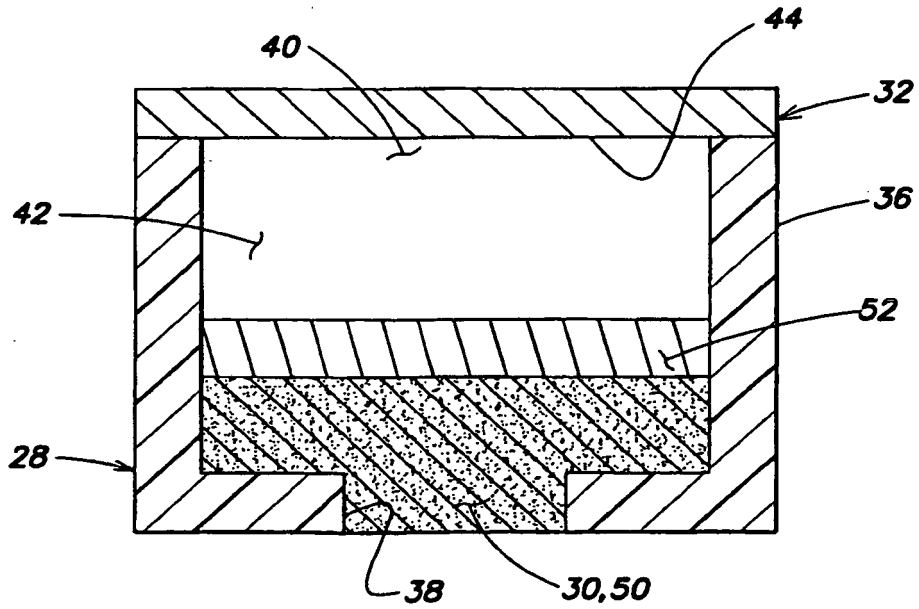

FIG. 5

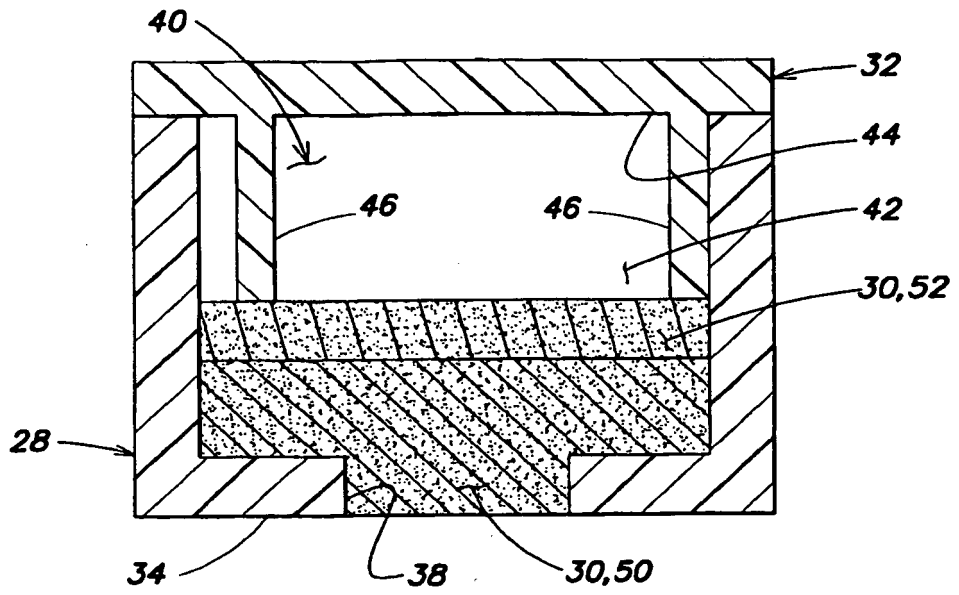

FIG. 5A

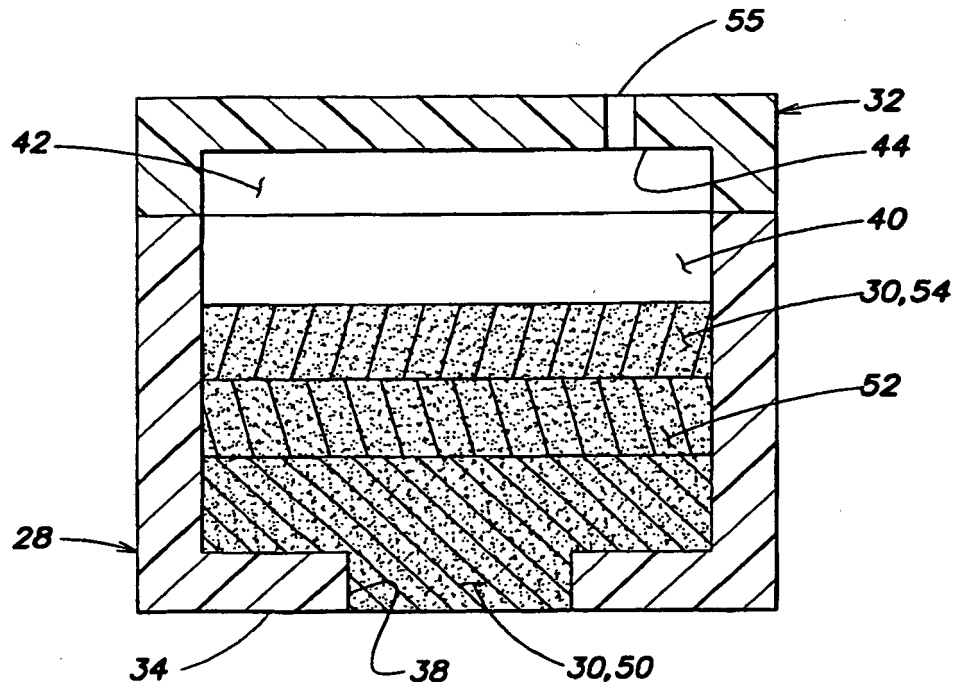

FIG. 5B

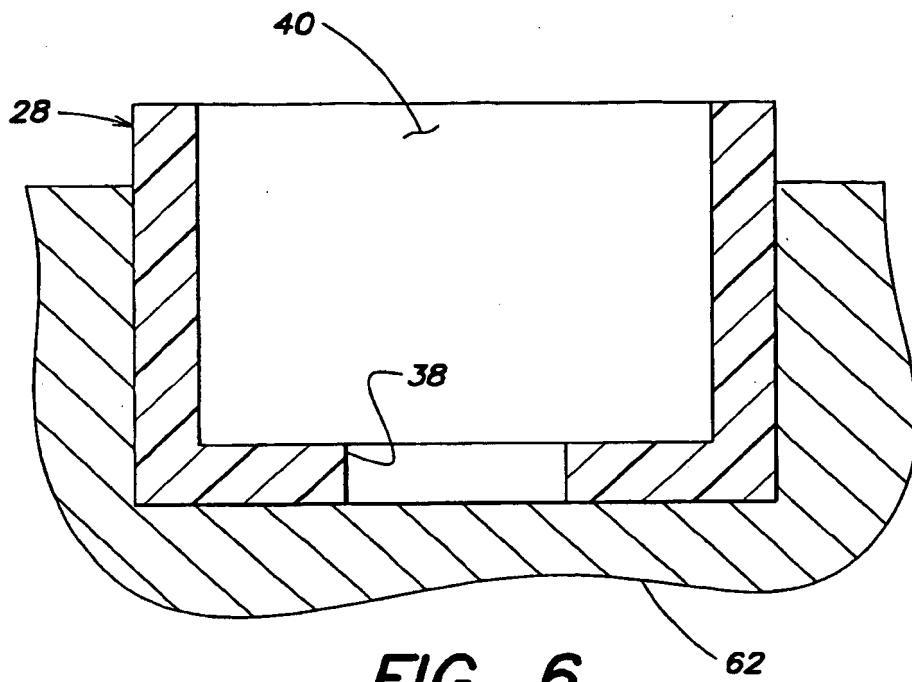

FIG. 6

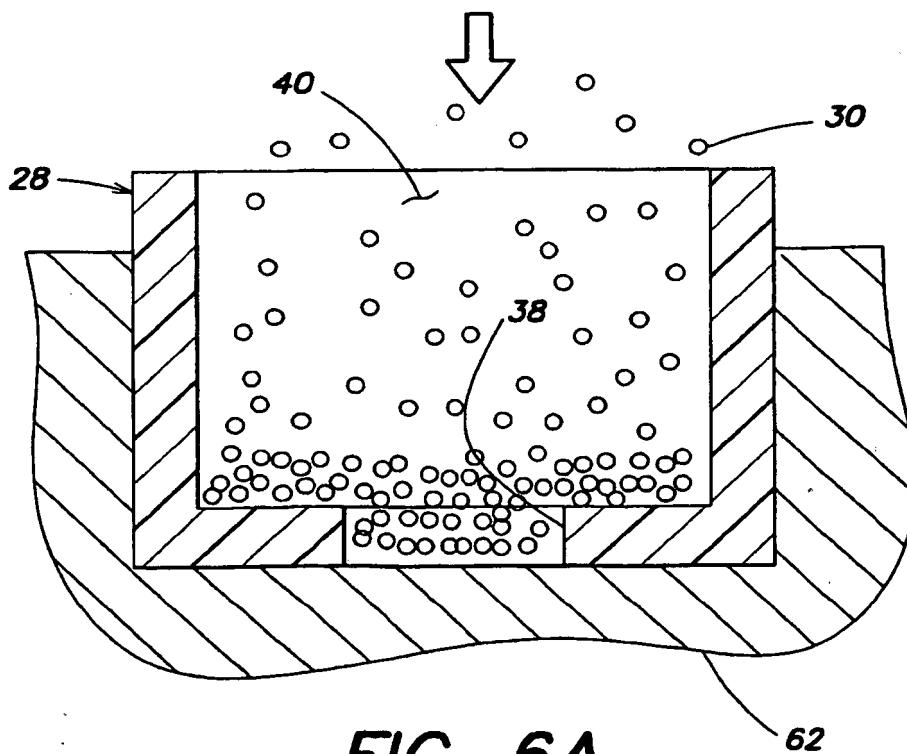

FIG. 6A

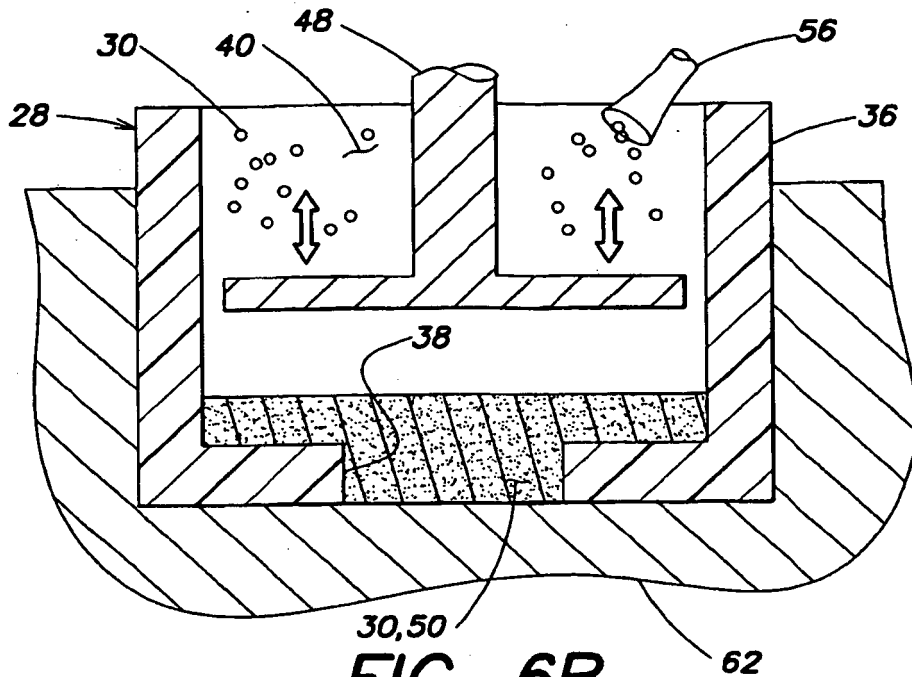

FIG. 6B

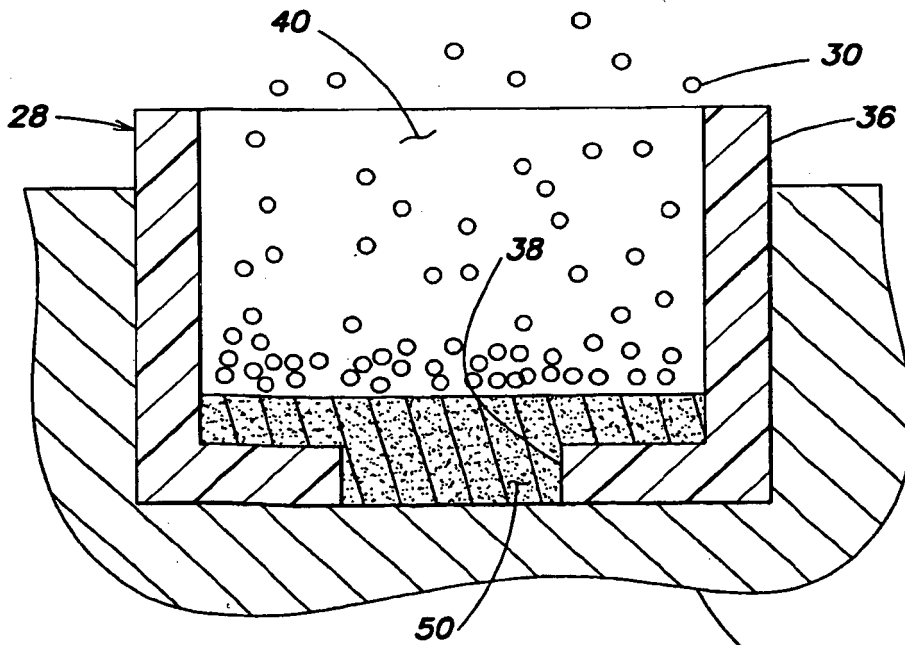

FIG. 6C

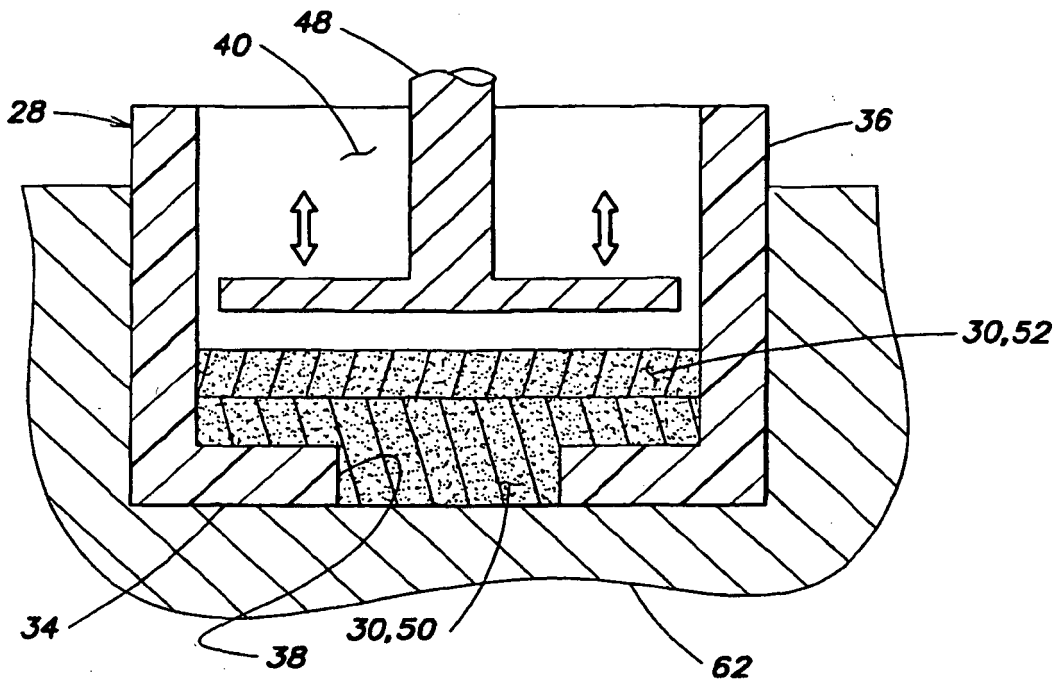

FIG. 6D

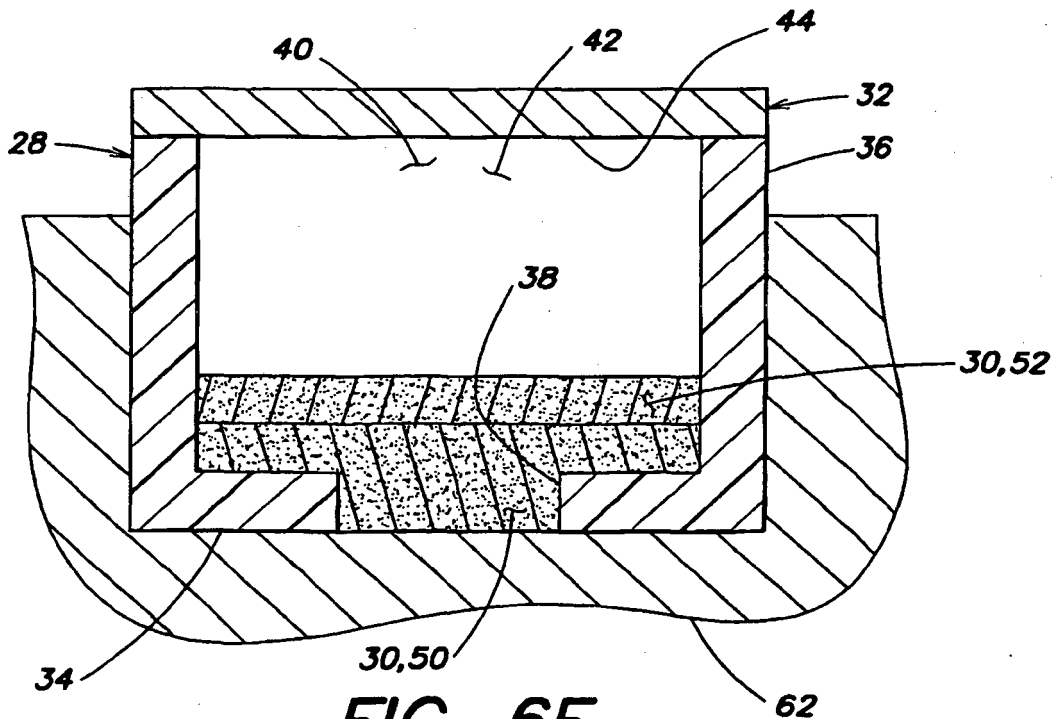

FIG. 6E

REFERENCES CITED IN THE DESCRIPTION

This list of references cited by the applicant is for the reader's convenience only. It does not form part of the European patent document. Even though great care has been taken in compiling the references, errors or omissions cannot be excluded and the EPO disclaims all liability in this regard.

Patent documents cited in the description

- WO 9602369 A [0004]
- US 5711076 A [0005]