



(11) **EP 2 503 585 A1**

(12) **EUROPEAN PATENT APPLICATION**

(43) Date of publication:  
**26.09.2012 Bulletin 2012/39**

(51) Int Cl.:  
**H01H 85/20 (2006.01) H01H 85/22 (2006.01)**

(21) Application number: **11006159.5**

(22) Date of filing: **27.07.2011**

(84) Designated Contracting States:  
**AL AT BE BG CH CY CZ DE DK EE ES FI FR GB GR HR HU IE IS IT LI LT LU LV MC MK MT NL NO PL PT RO RS SE SI SK SM TR**  
Designated Extension States:  
**BA ME**

- **Bartos, Dalibor**  
**66441 Troubsko (CZ)**
- **Halamíček Josef**  
**74787 Budisov nad Budisovkou (CZ)**
- **Ottich, Jaroslav**  
**69125 Vranovice (CZ)**

(30) Priority: **21.03.2011 CZ 20110143**

(74) Representative: **Sedlák, Jirí**

(71) Applicant: **DRIBO, spol. s.r.o.**  
**61900 Brno (CZ)**

**Husova 5**  
**P.O. Box 1**  
**CZ-370 01 České Budejovice (CZ)**

(72) Inventors:

- **Bartos, Stanislav**  
**66441 Troubsko (CZ)**

(54) **An extender for placement of a roller fuse in contact of current conductive path of electric switching and/or fuse device of high or very high voltage**

(57) The extender (1) is mainly used for installation of the cylindrical fuse (2) in the contacts (3) of the current conducting path (4) designed for shorter fuse of different terminal diameter (17). The extender (1) includes the fixing part (5) fitted with at least one external contact surface (6) and the sleeve (7) fitted with at least one internal contact surface (8). The sleeve (7) has a fixed, demountable or movable connection with the fixing part (5). The external dimension (D) of the fixing part (5) specified by the external contact surface (6) or multiple external contact surfaces (6) is larger or smaller than the internal bore diameter (d) of the sleeve (7) defined by the internal contact surface (8) or multiple internal contact surfaces (8).

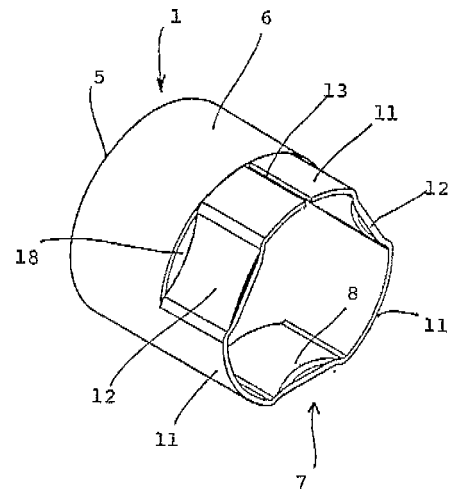

**FIG. 4**

**EP 2 503 585 A1**

## Description

### Field of the invention

**[0001]** The invention relates an extender for placement of a cylindrical fuse in contact of current conductive path of electric switching and/or fuse device of high or very high voltage, e.g. terminator, disconnecter, fuse holder, fuse receptacle etc.

### Background of the invention

**[0002]** At present, particularly the fuses with dimensions defined in IEC 60282-1 and differentiated by the voltage value are used for practical line protection of high or very high voltage grids. However in the past, fuses of different dimensions and types were used, particularly with longer length and larger diameters of the fuse terminals.

**[0003]** This situation of concurrent use of different fuse types for many years resulted in that today, there are many switching or fuse devices of different types of current-conductive paths and contacts adapted after installation of fuses of specific type and dimension in the high voltage and very high voltage networks. However, older types of fuses are not produced at all in some cases; in other cases these are the fuses at the end of their production cycle and therefore, they are very expensive their price being several times higher than the price of currently prevailing fuses.

**[0004]** Of course, operators of switching and fuse devices are trying to use the benefits of new, smaller and cheaper fuses in maintenance, repairs and reconstructions. However, they must deal with the problem of adaptation of these devices to smaller fuses in case of their installation in the existing devices. At present, the problem is resolved by either replacement of the full fuse receptacle including insulators and contacts with a new fuse receptacle with contacts dimensionally adapted to smaller fuses or replacement of the current path alone with the new contacts dimensionally adapted to smaller fuses.

**[0005]** Adaptation of the devices is technically feasible but the disadvantages are that all work with the fuse receptacle must be carried out when the line is down, i.e. during operation shutdown, which results in loss of energy consumption by customers, contractual sanctions, penalties etc. Also, labour costs of the assembly companies are rather high for works required for adaptation works. Bolts used on the old current conductive paths arc usually corroded, it is not possible to loose them and if damaged, the assembly time is much more longer and total costs are higher. For work under voltage, albeit this is technically feasible as well, these adaptations are rare with respect to their extent and number and for price reasons, it is not economically justifiable to employ special assembly groups trained and equipped for working under voltage.

**[0006]** There are extenders for extension of the fuse length and their fitting to a longer current conducting path with identical diameter of contacts, e.g. extender for extension of fuses for 12kV and their implementation in 24kV devices. In fact, this is a cylinder body fitted on terminal of the fuse, the diameter of which is reduced outside the fuse with the use of fitting so that the diameter identical to the fuse terminal is achieved and to fix it to a remote device contact. However, these extenders do not deal with the technical troubles of installations of shorter fuses where the contacts are of diameter different from the fuse terminals.

**[0007]** The purpose of the invention is formation of a universal extender designed for installation of a shorter cylinder fuse of smaller diameter to the contact of the current conductive path adapted to older fuses of longer length and larger diameter, which would remove all these imperfections and deal with less often situation where a stronger fuse must be installed in a smaller contact.

### Summary of the invention

**[0008]** These drawbacks are fully removed by the extender according to present invention. The subject matter of the invention is that the extender includes a fixing part fitted with at least one outer connection part adapted to electrically conductive fitting of fixing part in the contact and a sleeve fitted with at least one contact part adapted to electrically conductive fitting of the sleeve to the end of the cylindrical fuse. The external dimension of the fixing part defined by the external contact part(s) differs from internal bore diameter of the sleeve defined by the contact part(s). The sleeve and fixing part offer different connection methods: fixed, demountable or movable, e.g. by sliding. The fixing part may, but does not have to, be identical to the fuse terminal as regards shape, i.e. it may be either cylindrical or of different shape and the sleeve may offer a wide range of shape variants and construction designs. In one favourable embodiment of the invention, the external diameter of the fixing part is larger than the inner bore diameter of the sleeve and therefore, the extender is designed for installation of a shorter cylindrical fuse of smaller diameter to the contacts of the current conductive path designed for older fuses of longer length and larger diameter, which corresponds to vast majority of known devices. In another favourable embodiment of the invention, the dimensions of the extender are opposite and therefore, the external diameter of the fixing part is smaller than the inner bore diameter of the sleeve, i.e. the extender is designed for installation of a shorter cylindrical fuse of smaller diameter to the contacts of the current conductive path designed for older fuses of longer length and larger diameter.

**[0009]** For the purpose of this description, the term "external dimension of the fixing part" refers to both external diameter or similar dimension of in fact rotary part with at least one contact surface and diameter or similar dimension of a case, usually circumscribed circle or other

curve around multiple contact points that form the fixing part. The term "inner bore diameter of the sleeve" refers to internal diameter or similar dimension of in fact rotary part with at least one internal contact surface as well as internal distance between two opposite internal contact surfaces as well as diameter or similar dimension of a circle or a different curve inscribed among more internal contact parts of the sleeve. The term "contact part" refers especially to the parts of internal and external cylindrical surfaces, as well as explicitly any other construction elements with shapes formed by surfaces and parts of the surfaces, sets of points or discrete points the purpose of which is formation of electric-conductive link of two components.

**[0010]** In an advantageous embodiment of the invention, the sleeve is designed to allow change to inner bore diameter and fitted with a clamping jig to clamp the sleeve to the terminal of cylindrical fuse by reducing the inner bore diameter. Production of pressure is favourable in cases where construction design of the sleeve alone would not allow for sufficiently strong link connection, electric conductivity, and low transient resistance.

**[0011]** It is advantageous from the functional and production point of view when the fixing part consists of a cylindrical body shell of which forms external contact surface. Strictly speaking, the fixing part of this design corresponds to the original fuse terminal and fits easily in the contact of the current conducting path designed for this shape as regards diameter and shape.

**[0012]** From the production point of view, it is more advantageous when the sleeve is firmly connected with the fixing part of at least one bridge and therefore, the extender may be produced of a tube or as an extrusion from metal sheet to reduce production costs for the extender considerably.

**[0013]** In another advantageous embodiment of the invention focused on both low production costs as well as easy handling with the extender and achieving of good parameters in connection and conductivity, the sleeve consists, in fact, of a cylindrical body the shell of which is formed by alternating arches and inner arches created as extrusions of external arches, whereas tops of the internal arches touching the terminal of the cylindrical fuse form internal contact surfaces and define the internal bore diameter of the sleeve as diameter of the circle inscribed among tops of the internal arches.

**[0014]** For improved contact of the design described above, it is advantageous when at least one larger arc is terminated by a longitudinal cut in the sleeve axis direction and the clamping jig consists of either shaped gripper spring or screwing clamp that snugs the sleeve. Both favourable embodiments of the clamping jigs are sufficiently effective and easy for handling; in addition, a hosc clamp is favourable because this is a purchased part, achieves higher contact pressure and retains alignment of the sleeve with the fuse terminal in a better way, which is beneficial especially for the fuses with a dispatching pin.

**[0015]** Finally, it is advantageous when an insert with a movable small piston, which engages with the dispatching pin of the cylindrical fuse, is inserted inside the clamping part. This design is intended for use of the fuses with the dispatching pin, which activates after the fuse melts and the pin moves forward to the extender space where it pushes on the movable small piston, which makes a contact of the device with mechanically accumulated energy, e.g. spring device, which opens all line phases at the same time. These devices are mainly used for protection of motors and transformers.

**[0016]** The benefits of the extender according to this invention are especially that they allow simple use of modem, cheaper and shorter fuses of smaller diameter universally for all switching and fuse devices designed for longer fuses of larger diameter without any modifications of these devices. Installation of the fuse with the extender is usually possible under voltage without any shutdown. For installations where replacement of fuses under voltage is not possible, the shutdown time is very short and it counts to minutes compared to time required for modification of the devices counting to several hours.

#### Brief description of the drawings

**[0017]** The invention will be described using the drawings, where Fig. 1 shows side profile of the extender, Fig. 2 shows cross-section of the extender in A-A plane, Fig. 3 shows ground plan of the extender, Fig. 4 shows panoramic axonometric view on the extender, Fig. 5 shows panoramic axonometric view on the extender with clamping jig consisting of gripper spring, Fig. 6 shows panoramic axonometric view on the extender with clamping jig consisting of the hose clamp, Fig. 7 shows panoramic axonometric view on part of the fuse with the extender in contact with the current conducting path, Fig. 8 shows panoramic axonometric view on the full current conducting path with the fuse fitted with the extenders on both ends and located in the contacts, Fig. 9 shows the cross section of the extender with the insert with movable small piston and fitted on the fuse terminal with the dispatching pin, Fig. 10 shows the extender in longitudinal cross-section on the interface of the internal and external arc, Fig. 11 shows the extender with protruding external contact parts, Fig. 12 shows the extender with the sleeve tightened with the pin and spring, Fig. 13 shows the extender with the sleeve installed inside the fixing part, Fig. 14 shows the cylindrical extender with the sleeve consisting of the shell trim of the fixing part, Fig. 15 shows the cross-section of the extender according to Fig. 14. Fig. 16 shows the extender consisting of two cylindrical surfaces, Fig. 17 shows tube longitudinally-divided extender with the sleeve tightened with the tightening bolts, Fig. 18 shows the extender with bayonet-installed and axially shifted sleeve.

Examples of the preferred embodiments of the invention

**[0018]** It is assumed that the examples of embodiment of the invention are given as indicative examples and not as limitations of potential design of the invention to the examples given herein. The experts skilled in the art will find or will be able to find, with the use of routine experimentation, either higher or lower number of equivalents to specific embodiments of the invention specifically described herein. These equivalents will also be included in the extent of the following patent claims.

**[0019]** Fig. 1 to Fig. 9 shows example of the extender **1** embodiment, advantageously created from a tube or as an extrusion from metal sheet from current conducting copper alloy. Other material suitable from the electric properties and target operation equipment point of view may be used.

**[0020]** The extender **1** forms an integral extrusion where the fixing part **5** produced as a tube passes to the sleeve **7** via the bridge **10**. The fixing part **5**, the contact surface **6** of which consists of the tube shell, which defines the external dimension, here **D** diameter of the fixing part **5**, is designed for installation to the contact **3** of the current conducting path **4** of the relevant device. The sleeves **7** of two extenders **1** are installed to the terminals **17** of the cylindrical fuse **2** before the fuse **2** and the extenders **1** are installed in the contacts **3** of the current conducting path **4**.

**[0021]** The sleeve **7** is a body of roughly cylindrical shape the shell of which consists of alternating three external arches **11** and three internal arches **12**, whereas the tops of the internal arches **12** make contact with the terminals **17** of the cylindrical fuse **2** and they form internal contact surfaces **8** that define the internal bore diameter **d** of the sleeve **7** that is smaller than the external diameter **D** of the fixing part **5**. The bore diameter **d** indicates diameter of the circle inscribed among the tops of the internal arches **12**. The whole sleeve **7** may be favourably made of one tube semi-finished product with the fixing part **5** with the use of cuts **18**, which separate individual parts of the sleeve **7** from the fixing part **5** except for the bridge **10** forming the connection component.

**[0022]** One larger arc **11** is terminated by longitudinal section **13** made in the extender axis direction **1** along the length of the external arc **11**. The section **13** allows tightening of the sleeve **7** and thereby reducing of its internal bore diameter **d**, which is important both from the point of view of installation and conductivity of the extender **1** as well as achieving of alignment of the extenders **1** and the fuse **2**. The clamping jig **9** used for reduction may advantageously be formed from the gripper spring as shown on Fig. 5 and Fig. 8 or screwing clamp shown on Fig. 6 and 7. The clamping jig **9** may, however, have a wide range of examples of embodiment not shown here, for example clamps, clamping jaws made of a single piece or a double piece, pre-stressed springs and sleeves of various design, clamping screw joints, collets, rubber segments, strips and other binding components

etc.

**[0023]** Fig. 9 shows special example of the extender **1** where the fixing part **5** houses the insert **14** with the movable small piston **15**. This insert **14** is intended for the fuses **2** fitted with the dispatching pin **16**, which is activated for forward movement when the fuse **2** melts. The dispatching pin **16** pushes on the small piston **15**, which activates a device contact not displayed herein with mechanically accumulated energy, which disconnects all device phases at the same, in its ejected position inside the extender **1**.

**[0024]** It should be noted that the depicted example of the extender **1** is not the one and only possible. The fixing part **5** may be of different shapes and number of the external contact surfaces **6**, which do not have to form a continuous cylindrical surface but they must be capable of being fixed in the contact **3**. The sleeve **7** has more design options. It may be connected with the fixing part **5** with movable option, e.g. sliding to cover a wider range of the fuse lengths. It may be connected with the fixing part **5** as demountable option with either fixed or variable length. It may have a different number of internal contact surfaces **8** that may have different shape or design. The sleeve **7** may be of shape, among other, identical to the contact shape **3** but of smaller diameter. In each case, it must be able to fit to a terminal **17** of the fuse **2**.

**[0025]** Fig. 10 to Fig. 18 shows some other potential embodiments of the extender **1**.

Industrial applicability

**[0026]** The extender according to the invention can be used for installation of the cylindrical fuse in contact of the current conducting path of the electric switching and/or protection device of very high voltage or high voltage where the contacts are arranged for installation of longer fuse of either higher or smaller terminal diameter.

Summary of the numbers used in the drawings

**[0027]**

1	extender
2	cylindrical fuse
3	contact
4	current conducting path
5	fixing part
6	external contact surface
7	sleeve
8	internal contact surface

- 9 clamping jig
- 10 bridge
- 11 external arc
- 12 internal arc
- 13 cross-section
- 14 insert
- 15 small piston
- 16 dispatching pin
- 17 cylindrical fuse terminal
- 18 cut out
- D external dimension of the fixing part
- d internal bore diameter

#### Claims

1. The extender (1) for installation of the cylindrical fuse (2) in contact (3) of the current conducting path (4) of the electric switching and/or protection device of very high voltage or high voltage is **characterized by that** it includes the fixing part (5) fitted with at least one external contact surface (6) adapted to electrically conductive connection of the fixing part (5) in the contact (3) and the sleeve (7), which is either fixed, moveable or demountable and connected to the fixing part (5) and equipped with at least one internal contact surface (8) adapted for electrically conductive fixing of the sleeve (7) to the terminal (17) of the cylindrical fuse (2), whereas the external dimension (D) of the fixing part (5) specified by the external contact surface (6) or multiple contact surfaces (6) differs from the internal bore diameter (d) of the sleeve (7) defined by the internal contact surface (8) or multiple internal contact surfaces (8).
2. The extender according to claim 1 **characterized by that** the external dimension (D) of the fixing part (5) specified by the external contact surface (6) or multiple external contact surfaces (6) is larger than the internal bore diameter (d) of the sleeve (7) defined by the internal contact surface (8) or multiple internal contact surfaces (8).
3. The extender according to claim 1 **characterized by that** the external dimension (D) of the fixing part (5) specified by the external contact surface (6) or multiple external contact surfaces (6) is smaller than

the internal bore diameter (d) of the sleeve (7) defined by the internal contact surface (8) or multiple internal contact surfaces (8).

4. The extender according to claims 1 to 3 **characterized by that** the sleeve (7) is created with the possibility of change to the internal bore diameter (d) and fitted with the clamping jig (9) for clamping of the sleeve (7) to the terminal (17) of the cylindrical fuse (2) by lessening the bore diameter (d).
5. The extender according to claims 1 to 4 **characterized by that** the fixing part (5) consists of the cylindrical body the shell of which is formed by the external contact surface (6).
6. The extender according to claims 1 to 5 **characterized by that** the sleeve (7) is firmly fixed to the fixing part (5) with at least one bridge (10).
7. The extender according to claims 1 to 6 **characterized by that** the sleeve (7) is in fact formed by the cylindrical body the shell of which is formed by alternating external arches (11) and internal arches (12) formed as extrusions of external arches (11), whereas the tops of the internal arches (12) contacting the terminal (17) of the cylindrical fuse (2) form the internal contact surfaces (8) and define the internal bore diameter (d) of the sleeve (7).
8. The extender according to claim 7 **characterized by that** at least one external arc (11) is terminated by longitudinal cut (13) in the direction of the sleeve axis (7).
9. The extender according to claim 4 **characterized by that** the clamping jig (9) consists of the shaped gripper spring or screw joint clamp that snugs the sleeve (7).
10. The extender according to claims 1 to 9 **characterized by that** inside the fixing part (5) there is an insert (14) with moveable small piston (15) for the cylindrical fuses (2) with the dispatching pin (16).

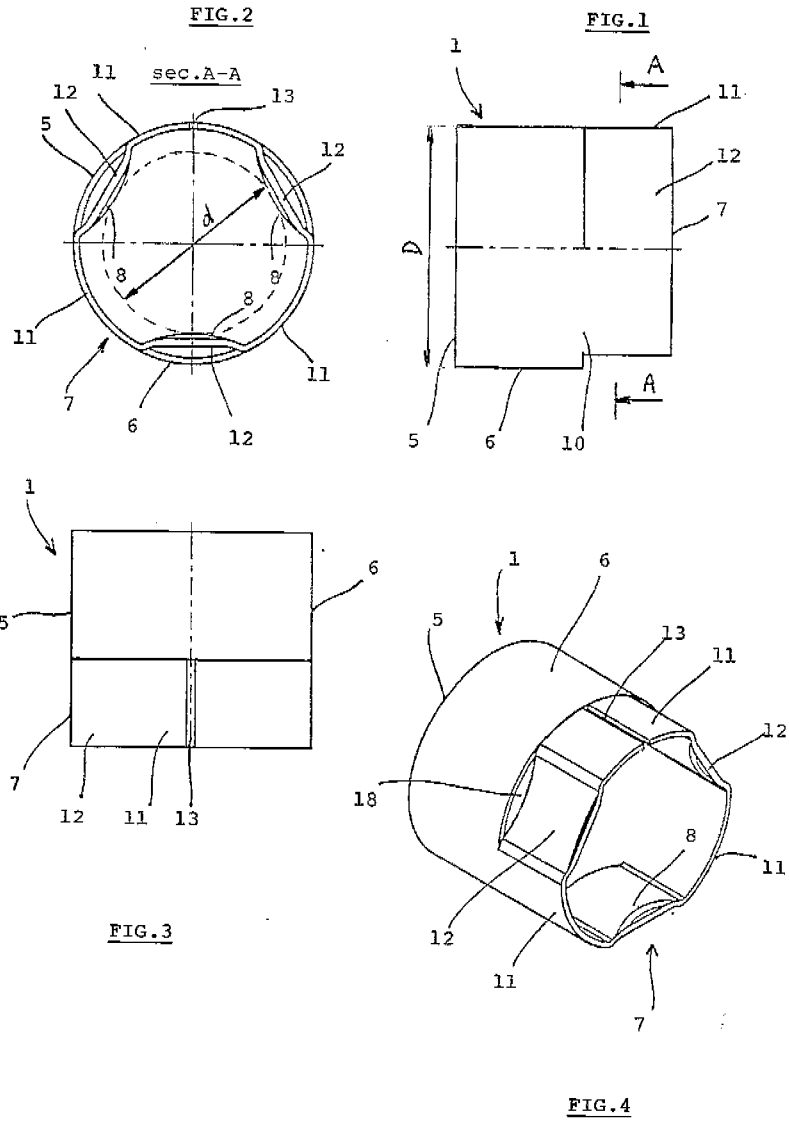

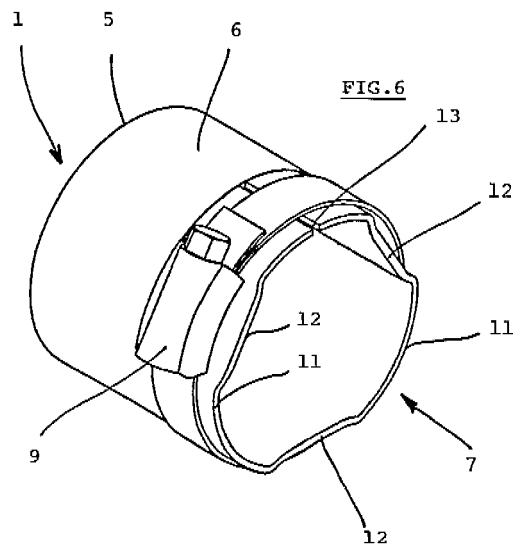
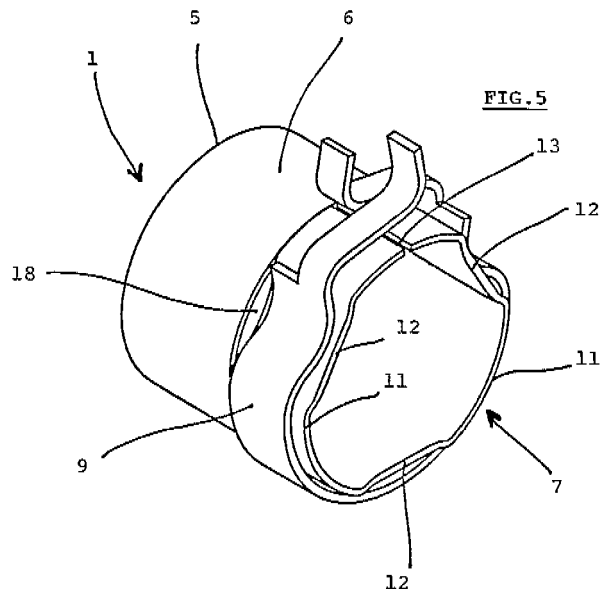

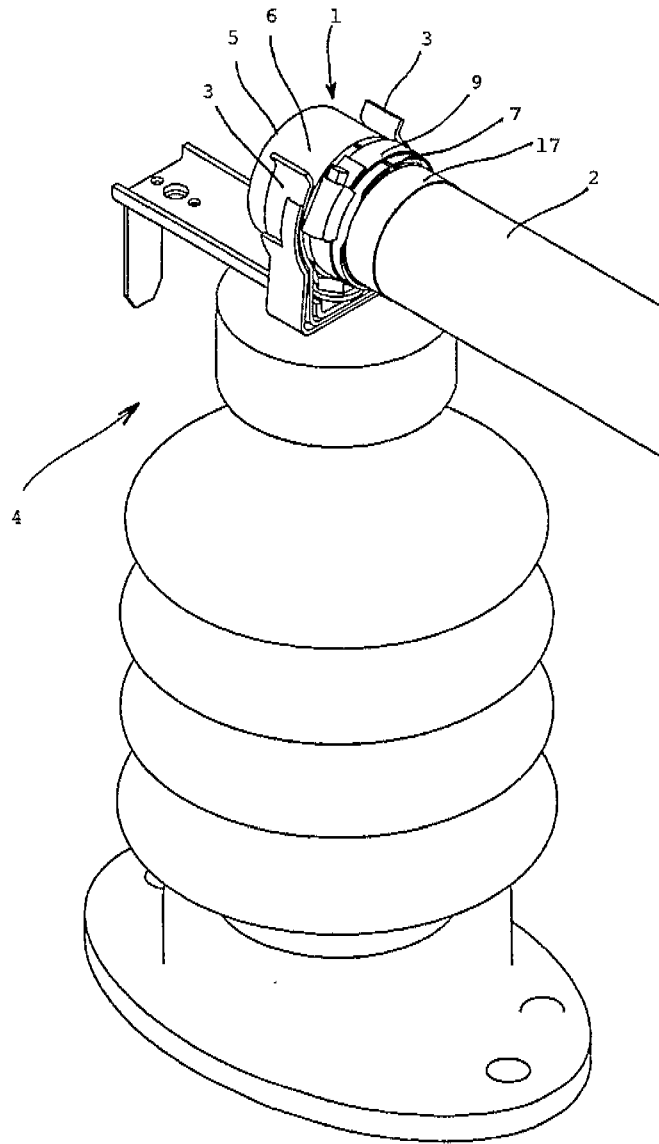
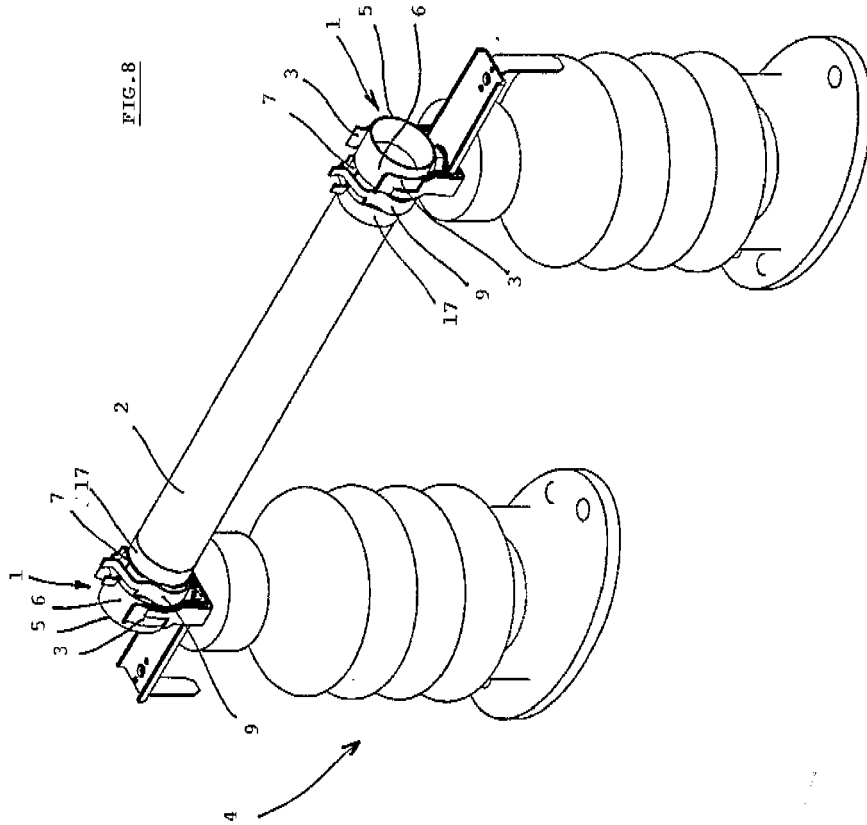
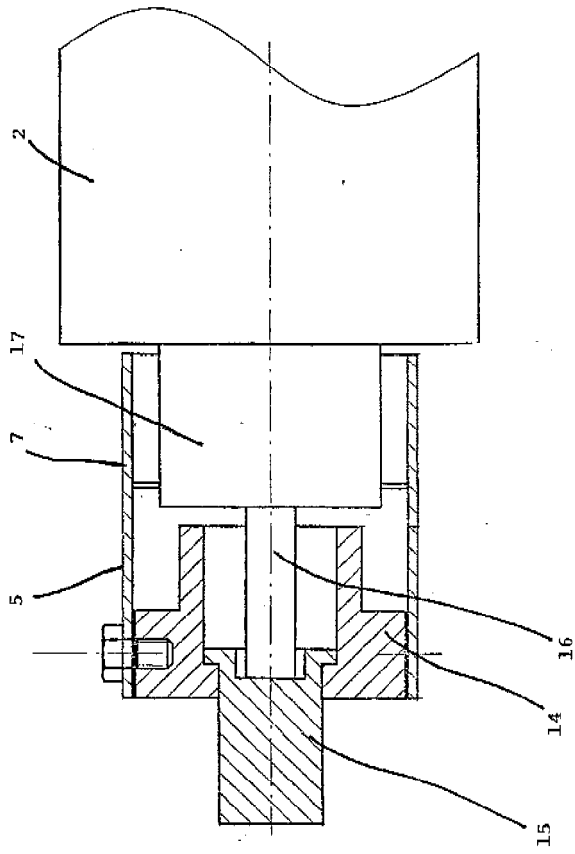
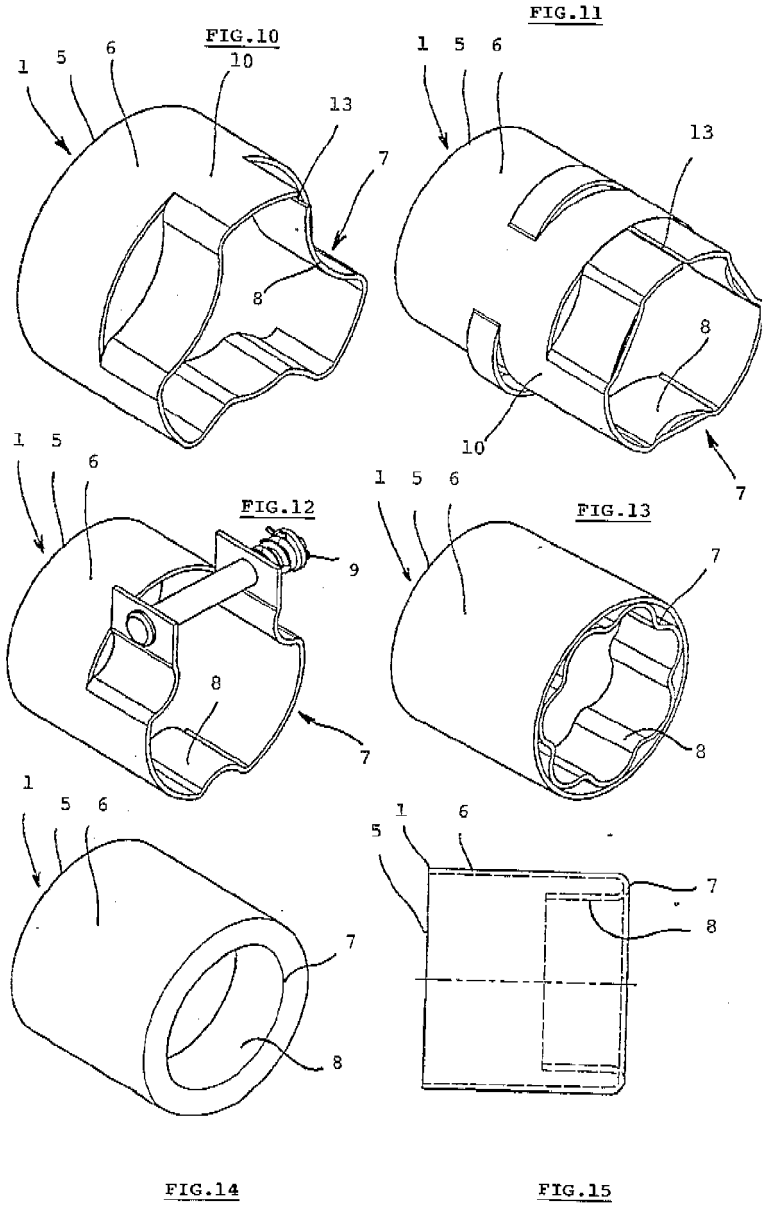
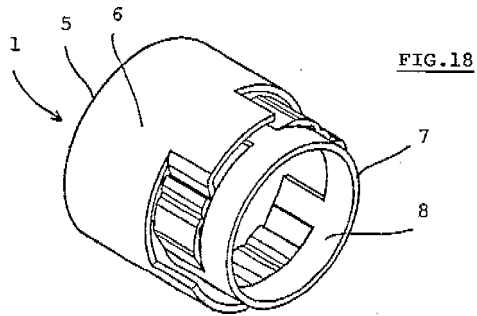
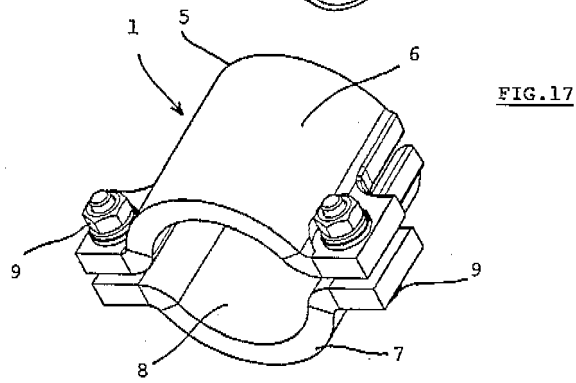
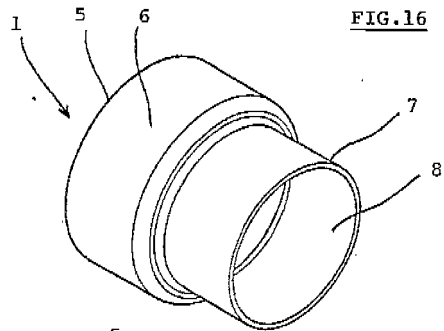

FIG. 7











EUROPEAN SEARCH REPORT

Application Number  
EP 11 00 6159

DOCUMENTS CONSIDERED TO BE RELEVANT			
Category	Citation of document with indication, where appropriate, of relevant passages	Relevant to claim	CLASSIFICATION OF THE APPLICATION (IPC)
X A	US 4 950 195 A (PERREAULT RICHARD J [US] ET AL) 21 August 1990 (1990-08-21) * figures 1-7 *	1-6,9 7,8,10	INV. H01H85/20 H01H85/22
X	----- Anonymous: "Online Catalog - Fuse Reducers", Grainger-Industrial Supply  25 May 2010 (2010-05-25), page 1, XP002678235, Retrieved from the Internet: URL:http://web.archive.org/web/20100525130915/http://www.grainger.com/Grainger/fuse-reducers/fuses/electrical/ecatalog/N-8cz?p=search&sst=subset [retrieved on 2012-06-19] * the whole document *	1-10	
X	----- Anonymous: "Miscellaneous Products - Fuse Reducers", Powr-Gard (TM) Products Catalog  5 December 2006 (2006-12-05), page 157, XP002678236, Retrieved from the Internet: URL:http://www.littelfuse.com/data/en/Data_sheets/lru.pdf [retrieved on 2012-06-19] * Third fuse with adaptor from left side.; page 157; figure 1 *	1-10	TECHNICAL FIELDS SEARCHED (IPC) H01H
The present search report has been drawn up for all claims			
Place of search Munich		Date of completion of the search 21 June 2012	Examiner Ernst, Uwe
CATEGORY OF CITED DOCUMENTS X : particularly relevant if taken alone Y : particularly relevant if combined with another document of the same category A : technological background O : non-written disclosure P : intermediate document		T : theory or principle underlying the invention E : earlier patent document, but published on, or after the filing date D : document cited in the application L : document cited for other reasons ----- & : member of the same patent family, corresponding document	

2  
EPO FORM 1503 03.82 (P/4C01)

**ANNEX TO THE EUROPEAN SEARCH REPORT  
ON EUROPEAN PATENT APPLICATION NO.**

EP 11 00 6159

This annex lists the patent family members relating to the patent documents cited in the above-mentioned European search report. The members are as contained in the European Patent Office EDP file on The European Patent Office is in no way liable for these particulars which are merely given for the purpose of information.

21-06-2012

Patent document cited in search report	Publication date	Patent family member(s)	Publication date
US 4950195 A	21-08-1990	CA 1311005 C US 4950195 A	01-12-1992 21-08-1990
-----			

EPO FORM P0459

For more details about this annex : see Official Journal of the European Patent Office, No. 12/82