

(19)



(11)

**EP 2 518 239 A1**

(12)

**EUROPEAN PATENT APPLICATION**

(43) Date of publication:

**31.10.2012 Bulletin 2012/44**

(51) Int Cl.:

**E04G 21/32 (2006.01)**

(21) Application number: **11382122.7**

(22) Date of filing: **28.04.2011**

(84) Designated Contracting States:

**AL AT BE BG CH CY CZ DE DK EE ES FI FR GB GR HR HU IE IS IT LI LT LU LV MC MK MT NL NO PL PT RO RS SE SI SK SM TR**

Designated Extension States:

**BA ME**

(72) Inventor: **Zuloaga Agirrebaltzategi, Aritz**  
**20560 OÑATI (Guipúzcoa) (ES)**

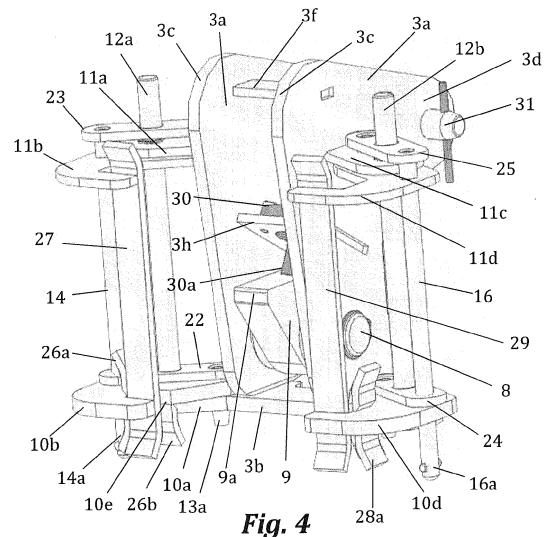
(74) Representative: **Carpintero Lopez, Francisco et al**  
**Herrero & Asociados, S.L.**  
**Alcalá 35**  
**28014 Madrid (ES)**

(71) Applicant: **ULMA C y E, S. COOP.**  
**20560 Oñati (Guipuzcoa) (ES)**

(54) **A climbing head for hoisting a self-climbing protection system for construction works in buildings**

(57) A climbing head being releasably fastenable to a mast (1) with longitudinal rear lateral flanges (1c) and support elements (2, 2a) at different heights; and comprising two vertical side plates (3a), hinging means (3e) for tiltably coupling the the side plates (3a) to a hoist cylinder (4) which is also coupled to anchoring means (5,6) fastened to a floor slab (7) of a building, a rocker member (9) pivotal between a hoist position where its front portion (9a) protrudes from the side plates (3a) and engages the mast (1) when the hoist cylinder (4) extends towards said extended position for hoisting the mast (1), and a passing position, in which it allows the passage of the mast (1) when the hoist cylinder (4) retracts, a lower and an claw (10, 11), locking means to lock each of the claws (10, 11) in a locked position where it embraces said lateral flanges (1c) and an open position in which the claw (10, 11) releases said flanges (1c); each claw (10, 11) comprises comprises two claw members, each comprising a fixed claw portion (10a, 10c, 11a, 11c) and movable claw portion (10b, 10d, 11 b, 11d) that is pivotal about a vertical rotation axis (12a, 12b), provided in the fixed claw portion (10a, 10c, 11a, 11c), between said locked and said open position, in vertically aligned first throughholes (17a, 17b; 18a, 18b; 19a, 19b; 20a, 20b) in the fixed (10a, 10c, 11 a, 11c) and in the movable claw portion (10b, 10d, 11 b, 11 d) and a second throughhole (21 a, 21 b; 21 c, 21 d) in the movable claw portion (10b, 10d, 11 b, 11 d) ; the locking means comprise each a vertical bolt (13a, 13b; 15a, 15b) which, in the claws' (10, 11) locked position, remains inserted in said first throughholes (17a, 17b; 18a, 18b; 19a, 19b; 20a, 20b), whereby left vertical bolts (13a, 13b) are connected to a left vertical rod (14) that extends slidingly through the left movable claw portions

(10a, 10b), the right vertical bolts (15a, 15b) are connected to a right vertical rod (16) that extends slidingly through the right movable claw portions (10d, 11d); the vertical rods (14, 16) each having a length such that their lower end portions (14a, 16a) remain guided in the respective second throughholes (21 a, 21 c) in the lower movable claw portions (10b, 10d) when said vertical bolts (13a, 13b, 15a, 15b) are pulled upwards out of said first throughholes (17a, 17b; 18a, 18b; 19a, 19b; 20a, 20b).



**Fig. 4**

**EP 2 518 239 A1**

**Description****TECHNICAL FIELD OF THE INTENTION**

[0001] The present invention is comprised within the technical field of construction of buildings and, more particularly, in the sector of formworks and of self-climbing perimetric protection systems for construction works in buildings and, specifically it relates to a climbing head for hoisting such protection systems.

**BACKGROUND OF THE INVENTION**

[0002] In the construction of high building, the need of working safely at great heights and at adverse meteorological conditions (wind or rain) has made it indispensable to install in the periphery of the framing perimetric protections which safeguard the physical integrity of workers.

[0003] These protections have historically been made up of simple railings. However, the concept of protection that is currently used, entirely covers the framing, for example the last three framing structures being worked on, with canvas, wooden boards, fences, wire mesh, etc. Such protection systems were first introduced on the Spanish market in non self-climbing versions, such as the protection system used by the Spanish company UL-MA Construcción in the Sacyr tower works in Madrid. In this version, each part of the peripheral protection system has to be hoisted by a crane and this took time away from the availability of the crane for performing other tasks on site. As can be concluded from the foregoing, it makes no sense to install a complex self-climbing system for the wall formworks of the central core of a building if the crane is later occupied for long periods of time to raise the peripheral protection system. On the other hand, automatic hoisting of the protection system is safer because it is not necessary for there to be people guiding the assemblies in dangerous working positions. To that end, there is currently a growing demand for the peripheral protection systems to be self-climbing, such that they can be hoisted independently from the remaining work tasks.

[0004] To meet this demand, self-climbing protection systems have been developed, such as, for example, those described in documents EP-A-1899548, EP-A-1899549 and EP-A-1902185. Basically, these self-climbing protection systems for construction works in a building comprise at least two masts spaced away from each other, each mast comprising two vertical beams having respective longitudinal outwardly protruding lateral flanges at their rear portions and a plurality of support elements fixed between the vertical beams at different heights. A vertical protection panel is attached to the masts, and a plurality of pairs of support elements is arranged in different horizontal planes between the beams of each of the masts for supporting the masts during the hoisting process for hoisting the masts and a working phase, and a plurality of pairs of anchor members im-

mobilized at different heights in a building for guiding the masts. These systems further comprise, in respect of each mast to be hoisted, a climbing head which is releasably fastenable to the mast and comprises two vertical side plates which are distanced from each other and linked together at their lower end portions and at their upper end portions; hinging means for tiltably coupling the upper portions of the side plates to the upper end of a hoist cylinder the lower end of which is coupled to an anchor member that is fastened to a rim portion of a floor slab of a building. The hoist cylinder is of adopting an extended position and a retracted position. The climbing head further comprises a rocker member that is pivotal between the hoist position where its front portion protrudes from the side plates and engages the mast when the hoist cylinder extends towards said extended position for hoisting the mast, and a passing position, in which it allows the passage of the mast when the hoist cylinder retracts to said retracted position. A lower left claw member and a lower right claw member each protruding laterally beyond one of the side plates and lower locking means to lock each of the lower claw members in a locked position where it embraces one of said lateral flanges and an open position in which the claw members release said lateral flanges are also provided.

[0005] Nevertheless, there continues to be a need in the construction sector to be able to have alternative self-climbing perimetric protection systems with respect to those known, which are reliable, easy and quick enough to handle and not excessively expensive, and which ensure effective and safe hoisting, the climbing head being one of the crucial elements of such systems inasmuch it is essential for hoisting and has to secure and bear the weight of all other elements of the system during hoisting.

**DESCRIPTION OF THE INVENTION**

[0006] The present invention is intended to improve the known self-climbing perimetric protection systems by providing a climbing head for hoisting a self-climbing protection system for construction works in buildings, the climbing head being releasably fastenable to a mast comprising two vertical beams having respective longitudinal outwardly protruding longitudinal lateral flanges at their rear portions and a plurality of support elements fixed between the vertical beams at different heights; and comprising two vertical side plates, distanced from each other and linked together at their lower end portions and at their upper end portions; hinging means for tiltably coupling the upper portions of the side plates to the upper end of a hoist cylinder the lower end of which is coupled to anchoring means fastened to a rim portion of a floor slab of a building, the hoist cylinder being capable of adopting an extended position and a retracted position; a rocker member that is pivotal between a hoist position where its front portion protrudes from the side plates and engages the mast when the hoist cylinder extends towards said extended position for hoisting the mast, and

a passing position, in which it allows the passage of the mast when the hoist cylinder retracts to said retracted position; a lower left claw member and a lower right claw member each protruding laterally beyond one of the side plates; lower locking means to lock each of the lower

claw members in a locked position where it embraces one of said lateral flanges and an open position in which the lower claw members release said lateral flanges, the climbing head being characterized in that

the climbing head further comprises an upper left claw member and an upper right claw member each protruding laterally beyond one of the side plates, and upper locking means to lock each of the upper claw members in a locked position where it embraces one of said lateral flanges and an open position in which the upper claw members release said lateral flanges;

each of the claw members comprises a fixed claw portion emerging from one side plate and movable claw portion that is pivotal about a vertical rotation axis provided in the fixed claw portion to which it is mounted, between said locked and said open position,;

the locking means comprise lower and upper left locking means and lower and upper right locking means, the locking means comprising each a vertical bolt which, in the claw member's locked position, remains removably inserted in vertically aligned first throughholes respectively provided in the fixed and in the movable claw portion between the respective vertical rotation axis and the respective side plate;

the vertical bolts of the left locking means are connected to a left vertical rod that extends slidingly through second throughholes provided respectively in the left movable claw portions at a position between its rotation axis and its free end;

the vertical bolts of the right locking means are connected to a right vertical rod that extends slidingly through second throughholes provided respectively in the right movable claw portions at a position between its rotation axis and its free end;

the vertical rods each have a length such that their lower end portions remain guided in the respective second throughholes in the lower movable claw portions when said vertical bolts are pulled upwards out of said first throughholes.

**[0007]** In accordance with an embodiment of the invention, the vertical bolts of the left locking means are connected respectively to a lower portion of the left vertical rod by means of a left lower connecting member and respectively to an upper portion of the left vertical rod by means of a left upper connecting member, and the vertical bolts of the right locking means are connected respectively to a lower portion of the right vertical rod by means of a right lower connecting member and respectively to an upper portion of the right vertical rod by means of a right upper connecting member. According to this embodiment, the left lower and upper movable claw members may pivot about a common left rotation axis comprised of a left vertical shaft that is mounted to the

left lower and upper fixed claw members; and the right lower and upper movable claw members may pivot about a common right rotation axis comprised of a right vertical pivot shaft that is mounted to the right lower and upper fixed claw members. In this latter case, an intermediate portion of each left connecting member may be additionally slidingly and rotably connected to the left vertical shaft and an intermediate portion of each right connecting member is additionally slidingly and rotably connected to the right vertical shaft. The vertical shafts each have a length such that the upper connecting member to which is connected remains guided on its upper portion when said vertical bolts are pulled upwards out of said first throughholes.

**[0008]** The rocker member may be pivotally mounted on a rotation shaft arranged between the side plates, and comprising a front portion and rear portion and an intermediate portion, the rocker member being pivotal between said hoist position where its rear portion abuts against a first limiting element arranged between the side plates and its front portion protrudes from the side plates towards the mast and supports one of the support elements when the hoist cylinder extends towards said extended position for hoisting the mast, and said passing position, in which it allows the passage of at least one of the support elements when the hoist cylinder retracts to said retracted position. The vertical side plates may be linked together at their lower end portions by an attachment plate, and at their upper end portions by an attachment bar. Also, each side plate may comprise a front edge facing the mast, with a convex upper section and an inclined section extending backwards between the first convex upper section and the attachment plate, whereas on the side opposite the convex upper section, each of the side plates may have a rear protuberance with a coupling opening for a coupling bolt that is coupleable the upper end of the hoist cylinder is coupled.

**[0009]** In a preferred embodiment, each of the movable claw portions has a free end portion provided with a recess in which, in said closed position of the claw member, at least a portion of one of said lateral flanges is guided.

**[0010]** According to this preferred embodiment, the climbing head may comprise a left vertical front guiding plate provided at respective front walls of the recesses of the movable left claw portions, and a right vertical front guiding plate provided at respective front walls of the recesses of the movable right claw portions. Each of the front guiding plates may comprise an outwardly-arched upper end portion protruding upwardly beyond the upper movable claw portion and an outwardly-arched lower end portion protruding downwardly below the lower movable claw portion.

**[0011]** The climbing head may also be provided with a left and a right vertical lateral guiding plate provided at respective lateral walls of the recesses of the lower movable claw portions. Each of the vertical lateral guiding plates may comprise an outwardly-arched upper end por-

tion protruding upwardly beyond the lower movable claw portion, and an outwardly-arched lower end portion protruding downwardly below the lower movable claw portion.

**[0012]** Also, the climbing head may comprise a left and a right vertical rear guiding plate provided at respective rear walls of the recesses of the lower movable claw portions. Each of the vertical rear guiding plates may comprise an outwardly-arched lower end portion protruding downwardly below the lower movable claw portion.

### **BRIEF DESCRIPTION OF THE DRAWINGS**

**[0013]** Hereinafter, aspects and embodiments of the invention will be described on the grounds of drawings wherein

figure 1 is a side view of a self-climbing protection system including a climbing head according to an embodiment of the present invention;

figure 2 is an enlarged view of the climbing head shown in figure 1;

figure 3 is a sectional view corresponding to line A-A of the mast shown in figure 1;

figure 4 is a front perspective view of the climbing head shown in figure 2 with its lower and upper claws in their closed positions;

figure 5 is a front elevational view of the climbing head shown in figure 3;

figure 6 is a top plan view of the climbing head shown in figure 3;

figure 7 is a front elevational view of the climbing head shown in figure 3 where the left and right locking means for the claws are in their upper positions to unlock the claws which are still in the closed position;

figure 8 is a top plan view of the climbing head shown in figure 3 with its claws in their open position;

figure 9 is a top plan view of the climbing head in the position shown in figure 8.

**[0014]** In these figures, there are reference numerals identifying the following elements

1 mast

1a vertical beams

1b central section

1c lateral flanges

2 support element

2a projection

5 3 climbing head

3a vertical side plates

3b attachment plate

10 3c upper convex sections

3d rear protuberances

15 3e coupling openings

3f attachment bar

3g first limiting element

20 3h support plate

4 hoist cylinder

25 4a upper end of the hoist cylinder

4b lower end of the hoist cylinder

5 anchor member

30 5a front portion

5b rear portion

35 5c fastening bolt

6 anchor head

6a front portion

40 6b rear portion

6c horizontal rotation shaft

45 6d stopper

6e vertical guides

7 floor slab

50 8 rotation shaft

9 rocker member

55 9a front portion of the rocker member

9b rear portion of the rocker member

10	lower claw	24	right lower connecting member
10a	lower fix left claw portion	25	right upper connecting member
10b	lower movable left claw portion	5 27	left vertical front guiding plate
10c	lower fix right claw portion	26a, 28a	left and a right vertical lateral guiding plate
10d	lower movable right claw portion	26b, 28b	rear guiding plate
11	upper claw	10 29	right vertical front guiding plate
11 a,	upper fix left claw portion	30	damper
11 b	upper movable left claw portion	15 30a	damper rod
11 c	upper fix right claw portion	31	coupling bolt
11 d	upper movable right claw portion		
10e	recess		
12a	left vertical pivot shaft		
12b	right vertical pivot shaft	25	
13a, 13b	left vertical bolts		
14	left vertical rod		
14a	lower portion of the left vertical rod	30	
14b	upper portion of the left vertical rod		
15a, 15b	right vertical bolts	35	
16	right vertical rod		
16a	lower portion of the right vertical rod		
16b	upper portion of the right vertical rod	40	
17a, 17b	first left lower throughholes		
18a, 18b	first left upper throughholes	45	
19a, 19b	first right lower throughholes		
20a, 20b	first right upper throughholes		
21 a, 21 b	second left throughholes	50	
21 c, 21 d	second right throughholes		
22	left lower connecting member	55	
23	left upper connecting member		

### EMBODIMENTS OF THE INVENTION

**[0015]** Figure 1 illustrates an embodiment of a climbing head -3-, hoist cylinder -4-, anchor member -5- and anchor head -6-, applied a mast -1- as part of a self-climbing protection system. Although figure 1 shows only one vertical mast -1- and thus only one climbing head -3-, hoist cylinder -4-, anchor member and anchor head -6-, it is understood, that the self-climbing protection system should comprise at least two parallel masts -1- to support the perimetric protection elements -as for example one or more protection panels (not shown in the drawings), and therefore at least two climbing heads -3-, two hoist cylinders -4- and two anchor heads -6-, as well as at least a pair of anchor members -5- fixed each to at least two floor slabs -7- arranged at different heights of the building structure. The hoist cylinder -4- is capable of adopting an extended position and a retracted position.

**[0016]** As shown in figure 1, the climbing head -3- is connected by means of a connecting bolt -3e- traversing through holes in the upper portions of the side plates -3a- (the left side plate is shown in dotted lines in figures 1 and 2) of the climbing head -3-, to the upper end -4a- of the hydraulic hoist cylinder -4- the lower end -4b- of which is connected the anchor head -5-. The hoist cylinder -4- operating the climbing head -3- may be powered and controlled by means of a hydraulic generation system (not shown in the drawings), which is preferably capable of simultaneously powering a plurality of hoist cylinders -4-. As also apparent from figure 3, the mast -1- comprises two vertical beams -1a- having respective outwardly-protruding longitudinal lateral flanges -1 c- at its front and rear portions. A plurality of support elements -2- having projections -2a- protruding from the rear portion of the mast -1- are fastened, for example by means of bolts or screws (not shown in the drawings) , each at a different height of the mast -1-, between the central portions -1 b- of the beams -1a-. The beams -1a- can be, for example, standard beams having a U-shaped cross section, such as UPN-180 channel irons of determined lengths provid-

ed with openings with an MK-type configuration which allows incorporating standard MK-type braces with a continuous configuration of standard simple attachments and openings which allows a great versatility when forming different types of protection structures: adapted to the desired floor height in each case, different sections adapted to the needs of each work, etc. Depending on the configuration of the protection panel conceived for each case, the latter can also be attached directly to the masts -1-. For example, if the panel is made with boards, the panel can be supported by standard horizontal wooden beams attached directly to the masts -1- with standard connectors.

**[0017]** The climbing head -3- comprises two vertical side plates -3a-, distanced from each other and linked together at their lower end portions by means of an attachment plate -3b- and at their upper end portions by means of an attachment bar -3f-, as well as hinging means -3e, 31- for tiltably coupling the upper portions of the side plates -3a- to the upper end -4a- of the hoist cylinder -4- the lower end -4b- of which is coupled to the anchor head -5- that is coupled to the anchor head -6- fastened to a rim portion of the floor slab -7-.

**[0018]** The vertical side plates -3a- comprise each a front edge facing the mast -1-, with a convex upper section -3c- and an inclined section extending backwards between the first convex upper section -3c- and the attachment plate -3b-, whereas on the side opposite the convex upper section -3c-, each of the side plates -3a- comprises a rear protuberance -3d- where the hinging means -3e, 31- i.e. a coupling openings -3e- for a coupling bolt -31-, are located for coupling the upper end -4a- of the hoist cylinder -4- to the climbing head -3-.

**[0019]** The rocker member -9- is pivotally mounted on a rotation shaft -8- arranged between the side plates -3a-, and comprises a front portion -9a- and rear portion -9b- and an intermediate portion, the rocker member -9- being pivotal between said hoist position where its rear portion -9b- abuts against a first limiting element -3g- arranged between the side plates -3a- and its front portion -9a- protrudes from the side plates -3a- towards the mast -1- and supports one of the support elements -2, 2a- when the hoist cylinder -4- extends towards said extended position for hoisting the mast -1-, and said passing position, in which it allows the passage of at least one of the support elements -2, 2a- when the hoist cylinder -4- retracts to said retracted position. The upward movement of the front portion -9a- of the rocker member -9- is limited by a damper 30- mounted to an inclined support plate -3h-. The damper -30- has a damper rod -30a- which contacts the upper side of the front portion -9a- of the rocker member -9- such that the rocker member -9- remains in the hoisting position unless when being in contact with a projection -2a- of a support element -2- when the climbing head -3- descends along the mast -1-.

**[0020]** The climbing head further comprises a lower claw -10- comprising a lower left claw member -10a, 10b- and a lower right claw member -10c, 10d- each protruding

laterally beyond one of the side plates -3a-, lower locking means to lock each of the lower claw members -10a, 10b, 10c, 10d- in a locked position where it embraces one of said lateral flanges -1 c- and an open position in which the claw members -10a, 10b, 10c, 10d- release said lateral flanges -1 c-, as well as an upper claw -11- comprising an upper left claw member -11 a, 11 b- and an upper right claw member -11c, 11 d- each protruding laterally beyond one of the side plates -3a-, and upper locking means to lock each of the claw members -11a, 11 b, 11c, 11 d- in a locked position where it embraces one of said lateral flanges -1 c- and an open position in which the claw members -11a, 11b, 11c, 11d- release said lateral flanges -1 c-.

**[0021]** Each of the claws members -10a, 10b, 10c, 10d, 11a, 11 b, 11c, 11d- comprises a fixed claw portion -10a, 10c, 11a, 11 c- and movable claw portion -10b, 10d, 11 b, 11 d- that is pivotal about a vertical rotation axis -12a, 12b-, provided in the fixed claw portion -10a, 10c, 11a, 11c- to which it is mounted, between said locked and said open position.

**[0022]** The left lower and upper movable claw members -10b, 11 b- pivot about a common left rotation axis comprised of a left vertical shaft -12a- that is mounted to the left lower and upper fixed claw members -10a, 11a-, and the right lower and upper movable claw members -10d, 11d- pivot about a common right rotation axis comprised of a right vertical pivot shaft -12b- that is mounted to the right lower and upper fixed claw members -10c, 11c-. An intermediate portion of each left connecting member -22, 23- is additionally slidingly and rotably connected to the left vertical shaft -12a- and an intermediate portion of each right connecting member -24, 25- is additionally slidingly and rotably connected to the right vertical shaft -12b-. The vertical shafts -12a, 12b- each have a length such that the upper connecting member -23, 25- to which is connected remains guided on its upper portion when said vertical bolts -13a, 13b, 15a, 15b- are pulled upwards out of said first throughholes -17a, 17b; 18a, 18b; 19a, 19b; 20a, 20b-. Each of the movable claw portions -10b, 11b; 10c, 10d- has a free end portion provided with a recess -10e- in which, in said closed position of the claw member -10a, 10b, 10c, 10d, 11 a, 11b, 11c, 11 d-, at least a portion of one of said lateral flanges -1 c- is guided.

**[0023]** The climbing head -3- further comprises a left vertical front guiding plate -27- provided at respective front walls of the recesses -3f- of the movable left claw portions -10b, 11b-, and a right vertical front guiding plate -29- provided at respective front walls of the recesses -10e- of the movable right claw portions -10d, 11 d-. Each of the front guiding plates -27, 29- comprises an outwardly-arched upper end portion protruding upwardly beyond the upper movable claw portion -11 b, 11 d-, and an outwardly-arched lower end portion protruding downwardly below the lower movable claw portion -10b, 10d-. The climbing head -3- is also be provided with a left and a right vertical lateral guiding plate -26a, 28a- provided at

respective lateral walls of the recesses -10e- of the lower movable claw portions -10b, 10d-. Each of the vertical lateral guiding plates -26a, 28a- comprises an outwardly-arched upper end portion protruding upwardly beyond the lower movable claw portion -10b, 10d-, and an outwardly-arched lower end portion protruding downwardly below the lower movable claw portion -10b, 10d-. Additionally, the climbing head -3- has a left and a right vertical rear guiding plate -26b, 28b- provided at respective rear walls of the recesses -10e- of the lower movable claw portions -10b, 10d-. Each of the vertical rear guiding plates -26b, 28b- may comprise an outwardly-arched lower end portion protruding downwardly below the lower movable claw portion -10b, 10d-. These guiding plates ensure proper guidance of the climbing head -3- when moving along the rear lateral flanges -1a- of the mast -1-.

**[0024]** Each claw -10, 11- has vertically aligned first throughholes -17a, 17b; 18a, 18b; 19a, 19b; 20a, 20b- respectively provided in the fixed -10a, 10c, 11 a, 11c- and in the movable claw portion -10b, 10d, 11b, 11 d- between the respective vertical pivot shaft -12a, 12b- and the respective side plate -3a-, and a second throughhole -21 a, 21 b; 21 c, 21 d- provided in the movable claw portion -10b, 11 b, 10d, 11 d- at a position between said pivot shaft -12a, 12b- and the free end of the movable claw portion -10b, 11b, 10d, 11 d-.

**[0025]** The locking means comprise lower and upper left locking means and lower and upper right locking means. The locking means comprise each a vertical bolt -13a, 13b; 15a, 15b- which, in the claw member's -10a, 10b, 10c, 10d, 11a, 11 b, 11c, 11 d- locked position, remains removably inserted in said first throughholes -17a, 17b; 18a, 18b; 19a, 19b; 20a, 20b-, the vertical bolts -13a, 13b- of the left locking means being connected to a left vertical rod -14- that extends slidingly through the second throughholes -21 a, 21b- in the left movable claw portions -10b, 11b-, the vertical bolts -15a, 15b- of the right locking means being connected to a right vertical rod -16- that extends slidingly through the second throughholes -21 c, 21 d- provided in the right movable claw portions -10d, 11 d-. Each of the vertical rods -14, 16- has a length such that their lower end portions -14a, 16a- remain guided in the respective second throughholes -21 a, 21 c- in the lower movable claw portions -10a, 11a- when said vertical bolts -13a, 13b, 15a, 15b- are pulled upwards out of said first throughholes -17a, 17b; 18a, 18b; 19a, 19b; 20a, 20b-. The vertical bolts -13a, 13b- of the left locking means are connected respectively to a lower portion -14a- of the left vertical rod -14- by means of a left lower connecting member -22- and respectively to an upper portion -14b- of the left vertical rod -14- by means of a left upper connecting member -23-. The vertical bolts -15a, 15b- of the right locking means are connected respectively to a lower portion -16a- of the right vertical rod -16- by means of a right lower connecting member -24- and respectively to an upper portion -16b- of the right vertical rod -16- by means of a right upper connecting member -25-.

**[0026]** As shown in figure 1, the anchor head -6- is releasably coupled to a front portion -5a- of the anchor member -5- which in turn is fixed to the floor slab -5- by means of fastening bolts-. Only one bolt -5c- is shown in figure 1 but it is understood that a plurality of bolts may be provided. The front portion -5a- of the anchor member -5- is fastened to the rear portion -5b- thereof, and protrudes beyond the outer rim of the floor slab -7-. The anchor member -6- comprises two mobile horizontal claw members -6a- which, in the closed position, brace the rear flanges -1 c- of the mast -1-, and a supporting rocker -6b- with a front portion -6b'- adjacent to the mast -1-, an intermediate portion traversed by a horizontal rotation shaft -6c- and a rear part -6b-, such that the bearing rocker -6- is pivots between a working position in which said front portion -6a- protrudes towards the mast -1- and supports the projection -2a- of one of the support elements -2- of the mast -1- and a release position in which it is distanced from the mast -1- to allow said projection -2a- to be overcome when the mast is hoisted by action of the climbing head -3- and the hoist cylinder -4-. In the working position of the supporting rocker -6-, the rear portion -6b- thereof abuts against a stopper -6d-. The supporting rocker -6b-, the claw members -6a- and the stopper -6d- are mounted to a pair of side plates (not shown in the drawings). The movable portions of the claw members -6a- are provided with vertical guides -6e- that embrace the front lateral flanges -1c- of the mast -1- to enhance secure positioning of the mast -1- both when supported by the anchor member -6- and when being hoisted.

**[0027]** When the climbing head -3- is pulled upwards by means of the hoist cylinder -4-, due to the eccentricity of the thrusting force caused by the position of the coupling bolt -3e- to which the hydraulic cylinder -4- is articulated, the upper portion of the climbing head -3- tilts towards the mast -1- such that the arched sections -3c- of the front edges of the side plates -3a- contact the mast -1-. Upon following its upward path, the upper surface of the front portion -9a- of the rocker member -9- abuts with the lower surface of the projection -2a- of the corresponding self-climbing block -2- and then pushes the block -2- upwards so that the mast -1- is hoisted.

**[0028]** Once one of support members -2- located at a selected height of the mast -1- has surpassed the anchor member -6- and the hydraulic cylinder -4- is retracted, the projection -2a- of the support element -2- comes to rest on the front portion -6a- of the supporting rocker -6-. In turn, the climbing head -3- moves downward along the mast -1- guided by the closure of its claws -10, 11- and the front portion -9a- of its rocker member -9- rotates backwards against the action of the damper -30-, allowing the passage of the projection or projections -2a- of one or more of the support elements -2-.

**[0029]** When the hydraulic cylinder -25- has reached the desired retracted position, it is again extended, pulling the climbing head -3- upwards again such that the front portion -9a- of the rocker member -9- again abuts with the lower surface of the projection -2a- of a subsequent

support element -2- and pushes it upwards whereby the mast -1- is hoisted to the next position. Thereby, the masts -1- and the thereto attached elements are hoisted successively to higher positions until they are arranged at the desired height.

## Claims

1. A climbing head for hoisting a self-climbing protection system for construction works in buildings, the climbing head (3) being releasably fastenable to a mast (1) comprising two vertical beams (1a) having respective longitudinal outwardly protruding longitudinal lateral flanges (1c) at their rear portions and a plurality of support elements (2, 2a) fixed between the vertical beams (1 a) at different heights; and comprising two vertical side plates (3a), distanced from each other and linked together at their lower end portions and at their upper end portions; hinging means (3e) for tiltably coupling the upper portions of the side plates (3a) to the upper end (4a) of a hoist cylinder (4) the lower end (4b) of which is coupled to anchoring means (5, 6) fastened to a rim portion of a floor slab (7) of a building, the hoist cylinder (4) being capable of adopting an extended position and a retracted position; a rocker member (9) that is pivotal between a hoist position where its front portion (9a) protrudes from the side plates (3a) and engages the mast (1) when the hoist cylinder (4) extends towards said extended position for hoisting the mast (1), and a passing position, in which it allows the passage of the mast (1) when the hoist cylinder (4) retracts to said retracted position; a lower claw (10) comprising a lower left claw member (10a, 10b) and a lower right claw member (10c, 10d) each protruding laterally beyond one of the side plates (3a); lower locking means to lock each of the lower claw members (10a, 10b, 10c, 10d) in a locked position where it embraces one of said lateral flanges (1c) and an open position in which the lower claw members (10a, 10b, 10c, 10d) release said lateral flanges (1c); **characterized in that** the climbing head (3) further comprises an upper claw (11) comprising an upper left claw member (11 a, 11 b) and an upper right claw member (11c, 11 d) each protruding laterally beyond one of the side plates (3a), and upper locking means to lock each of the upper claw members (11a, 11 b, 11c, 11 d) in a locked position where it embraces one of said lateral flanges (1c) and an open position in which the upper claw members (11 a, 11 b, 11c, 11 d) release said lateral flanges (1 c); each of the claws members (10a, 10b, 10c, 10d, 11a, 11 b, 11c, 11 d) comprises a fixed claw portion (10a, 10c, 11a, 11c) emerging from one side plate (3a) and a movable claw portion (10b, 10d, 11 b, 11 d) that is pivotal about a vertical rotation axis (12a, 12b),

provided in the fixed claw portion (10a, 10c, 11a, 11c) to which it is mounted, between said locked and said open position ;

the locking means comprise lower and upper left locking means and lower and upper right locking means, the locking means comprising each a vertical bolt (13a, 13b; 15a, 15b) which, in the claw member's (10a, 10b, 10c, 10d, 11a, 11b, 11c, 11 d) locked position, remains removably inserted in vertically aligned first throughholes (17a, 17b; 18a, 18b; 19a, 19b; 20a, 20b) respectively provided in the fixed (10a, 10c, 11a, 11c) and in the movable claw portion (10b, 10d, 11 b, 11 d) between the respective vertical rotation axis (12a, 12b) and the respective side plate (3a);

the vertical bolts (13a, 13b) of the left locking means are connected to a left vertical rod (14) that extends slidingly through second throughholes (21 a, 21 b) provided respectively in the left movable claw portions (10b, 11 b) at a position between its rotation axis (12a) and its free end;

the vertical bolts (15a, 15b) of the right locking means are connected to a right vertical rod (16) that extends slidingly through second throughholes (21 c, 21 d) provided respectively in the right movable claw portions (10d, 11d) at a position between its rotation axis (12b) and its free end;

each of the vertical rods (14, 16) has a length such that their lower end portions (14a, 16a) remain guided in the respective second throughholes (21 a, 21 c) in the lower movable claw portions (10b, 10d) when said vertical bolts (13a, 13b, 15a, 15b) are pulled upwards out of said first throughholes (17a, 17b; 18a, 18b; 19a, 19b; 20a, 20b).

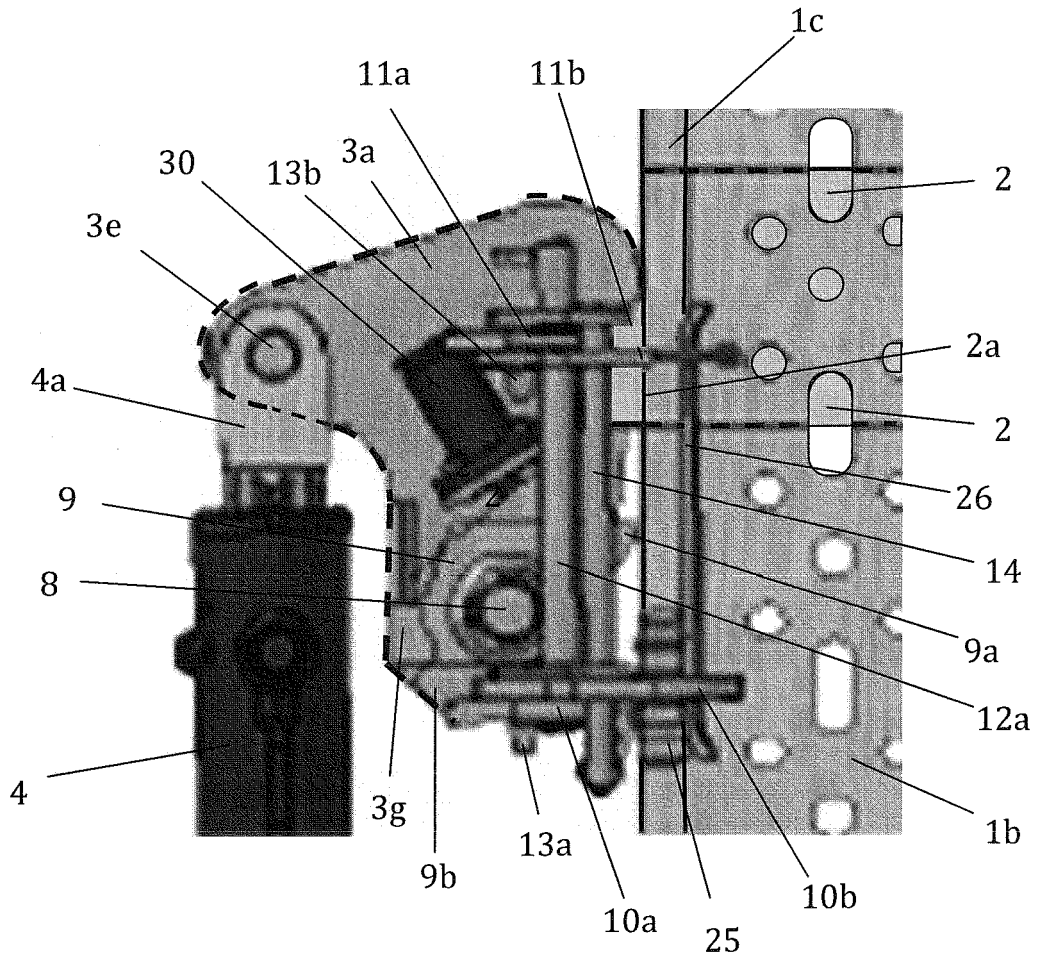
2. A climbing head according to claim 1, **characterized in that** the vertical bolts (13a, 13b) of the left locking means are connected respectively to a lower portion (14a) of the left vertical rod (14) by means of a left lower connecting member (22) and respectively to an upper portion (14b) of the left vertical rod (14) by means of a left upper connecting member (23), and the vertical bolts (15a, 15b) of the right locking means are connected respectively to a lower portion (16a) of the right vertical rod (16) by means of a right lower connecting member (24) and respectively to an upper portion (16b) of the right vertical rod (16) by means of a right upper connecting member (25).

3. A climbing head according to claim 2, **characterized in that** the left lower and upper movable claw members (10b, 11 b) pivot about a common left rotation axis comprised of a left vertical shaft (12a) that is mounted to the left lower and upper fixed claw members (10a, 11 a); the right lower and upper movable claw members (10d, 11 d) pivot about a common right rotation axis

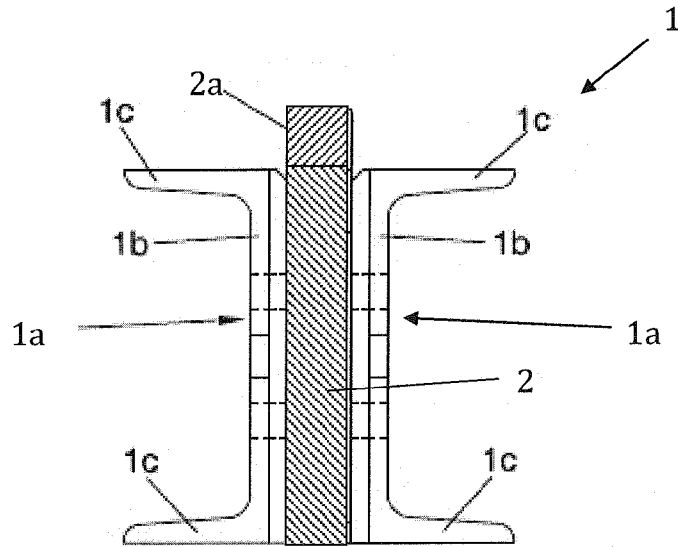
comprised of a right vertical pivot shaft (12b) that is mounted to the right lower and upper fixed claw members (10c, 11 c).

4. A climbing head according to claim 3, **characterized in that** an intermediate portion of each left connecting member (22, 23) is additionally slidingly and rotably connected to the left vertical shaft (12a) and an intermediate portion of each right connecting member (24, 25) is additionally slidingly and rotably connected to the right vertical shaft (12b); the vertical shafts (12a, 12b) each having a length such that the upper connecting member (23, 25) to which is connected remains guided on its upper portion when said vertical bolts (13a, 13b, 15a, 15b) are pulled upwards out of said first throughholes (17a, 17b; 18a, 18b; 19a, 19b; 20a, 20b).
5. A climbing head according to any of the preceding claims, **characterized in that** the rocker member (9) is pivotally mounted on a rotation shaft (8) arranged between the side plates (3a), and comprising a front portion (9a) and rear portion (9b) and an intermediate portion, the rocker member (9) being pivotal between said hoist position where its rear portion (9b) abuts against a first limiting element (3g) arranged between the side plates (3a) and its front portion (9a) protrudes from the side plates (3a) towards the mast (1) and supports one of the support elements (2, 2a) when the hoist cylinder (4) extends towards said extended position for hoisting the mast (1), and said passing position, in which it allows the passage of at least one of the support elements (2, 2a) when the hoist cylinder (4) retracts to said retracted position.
6. A climbing head according to claim 5, **characterized in that** the vertical side plates (3a) are linked together at their lower end portions by an attachment plate (3b), and at their upper end portions by an attachment bar (3f).
7. A climbing head according to claim 6, **characterized in that** each side plate (3a) comprises a front edge facing the mast (1), with a convex upper section (3c) and an inclined section extending backwards between the first convex upper section (3c) and the attachment plate (3b); on the side opposite the convex upper section (3c), each of the side plates (3a) has a rear protuberance (3d) with a coupling opening (3e) for a coupling bolt (31) that is couplable the upper end of the hoist cylinder (4) is coupled.
8. A climbing head according to any of the preceding claims, **characterized in that** each of the movable claw portions (10b, 11b; 10c, 10d) has a free end portion provided with a recess (10e) in which, in said closed position of the claw member (10a, 10b, 10c, 10d, 11 a, 11 b, 11c, 11 d), at least a portion of one of said lateral flanges (1c) is guided;
9. A climbing head according to claim 8, **characterized in that** it comprises a left vertical front guiding plate (27) provided at respective front walls of the recesses (3f) of the movable left claw portions (10b, 11b), and a right vertical front guiding plate (29) provided at respective front walls of the recesses (10e) of the movable right claw portions (10d, 11d).
10. A climbing head according to claim 9, **characterized in that** each front guiding plate (27, 29) comprises an outwardly-arched upper end portion protruding upwardly beyond the upper movable claw portion (11 b, 11 d), and an outwardly-arched lower end portion protruding downwardly below the lower movable claw portion (10b, 10d).
11. A climbing head according to claim 8, **characterized in that** it comprises a left and a right vertical lateral guiding plate (26a, 28a) provided at respective lateral walls of the recesses (10e) of the lower movable claw portions (10b, 10d) .
12. A climbing head according to claim 11, **characterized in that** each vertical lateral guiding plate (26a, 28a) comprises an outwardly-arched upper end portion protruding upwardly beyond the lower movable claw portion (10b, 10d), and an outwardly-arched lower end portion protruding downwardly below the lower movable claw portion (10b, 10d).
13. A climbing head according to claim 8, **characterized in that** it comprises a left and a right vertical rear guiding plate (26b, 28b) provided at respective rear walls of the recesses (10e) of the lower movable claw portions (10b, 10d).
14. A climbing head according to claim 13, **characterized in that** each vertical rear guiding plate (26b, 28b) comprises an outwardly-arched lower end portion protruding downwardly below the lower movable claw portion (10b, 10d).

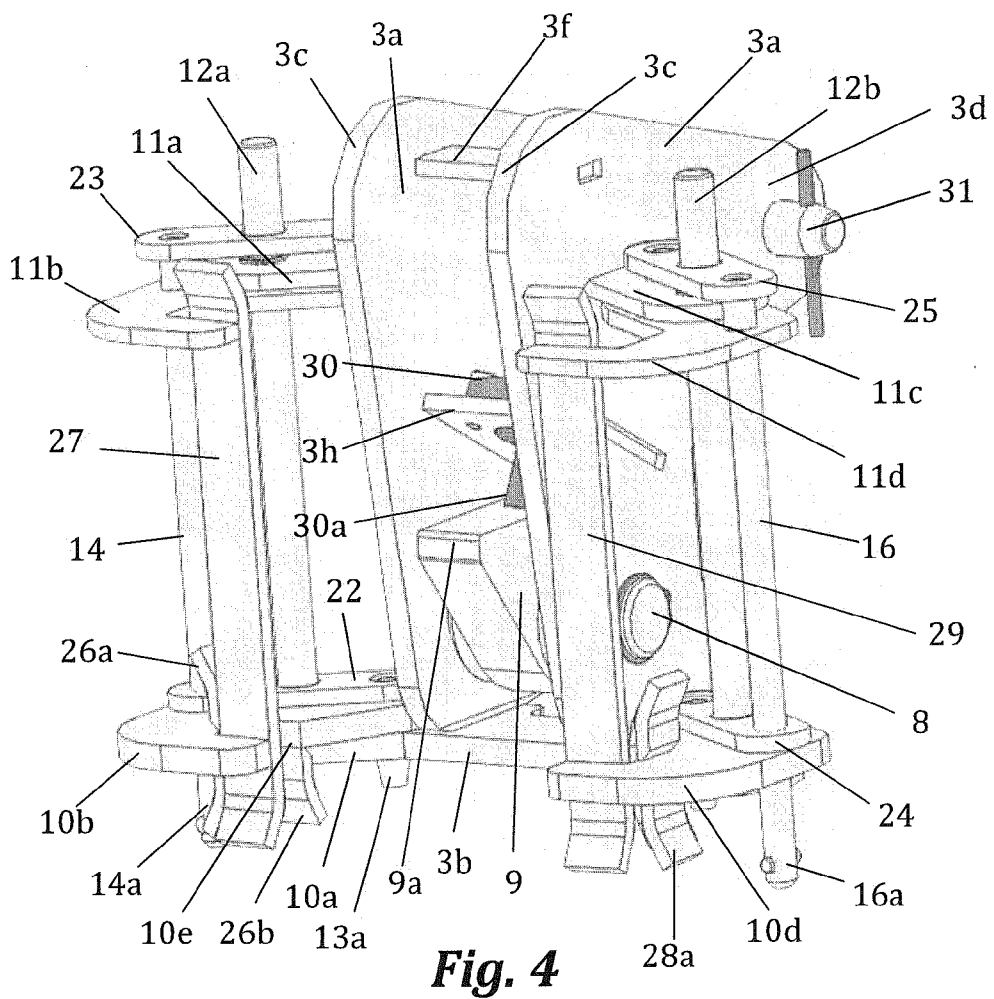




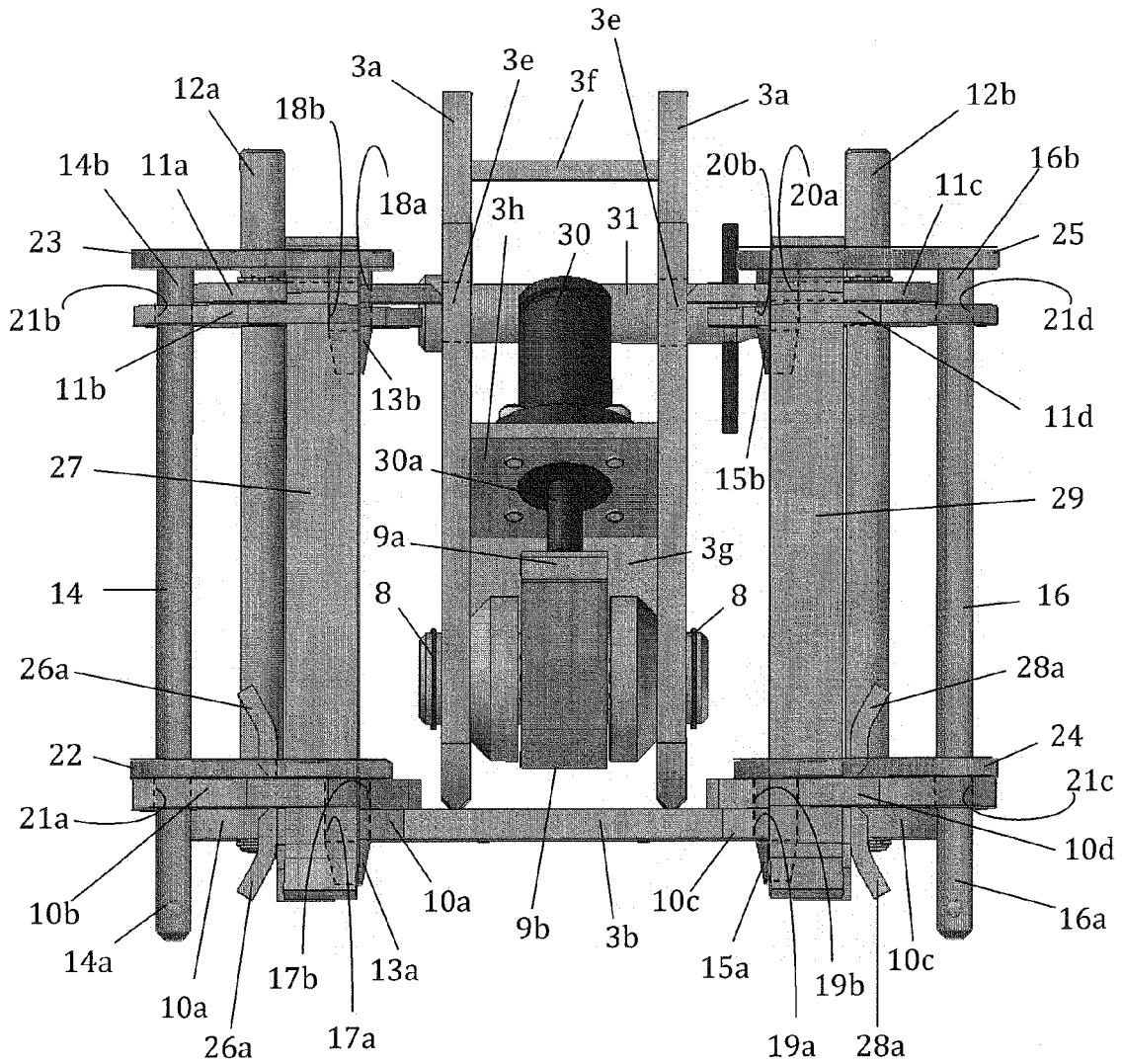
**Fig. 2**



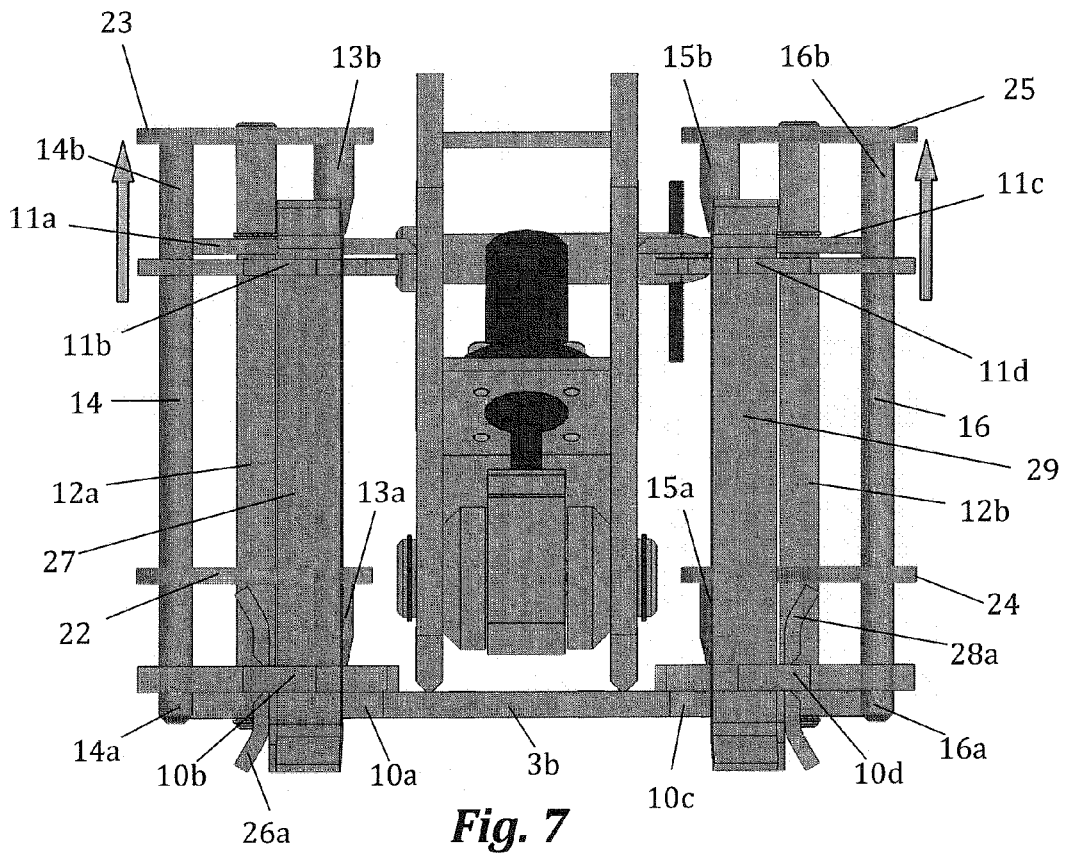
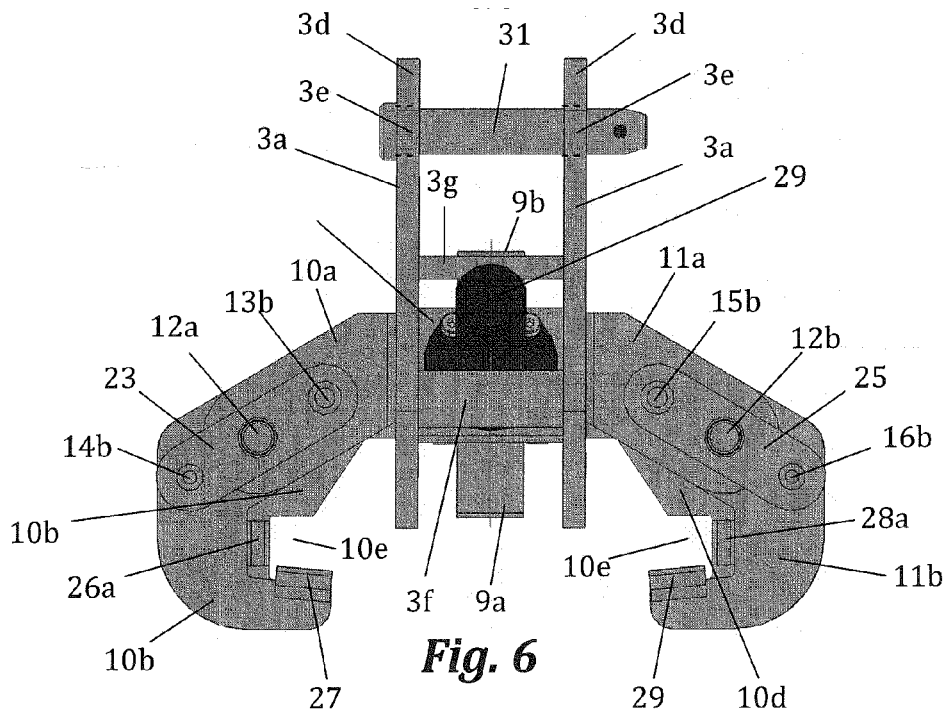
**Fig. 3**

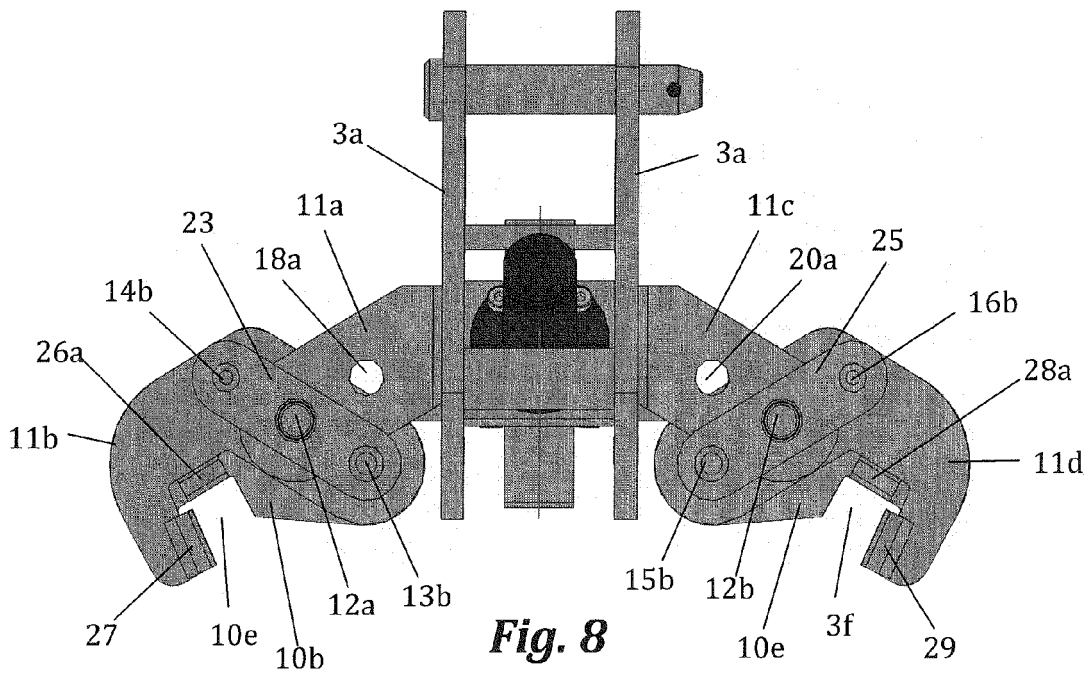


**Fig. 4**

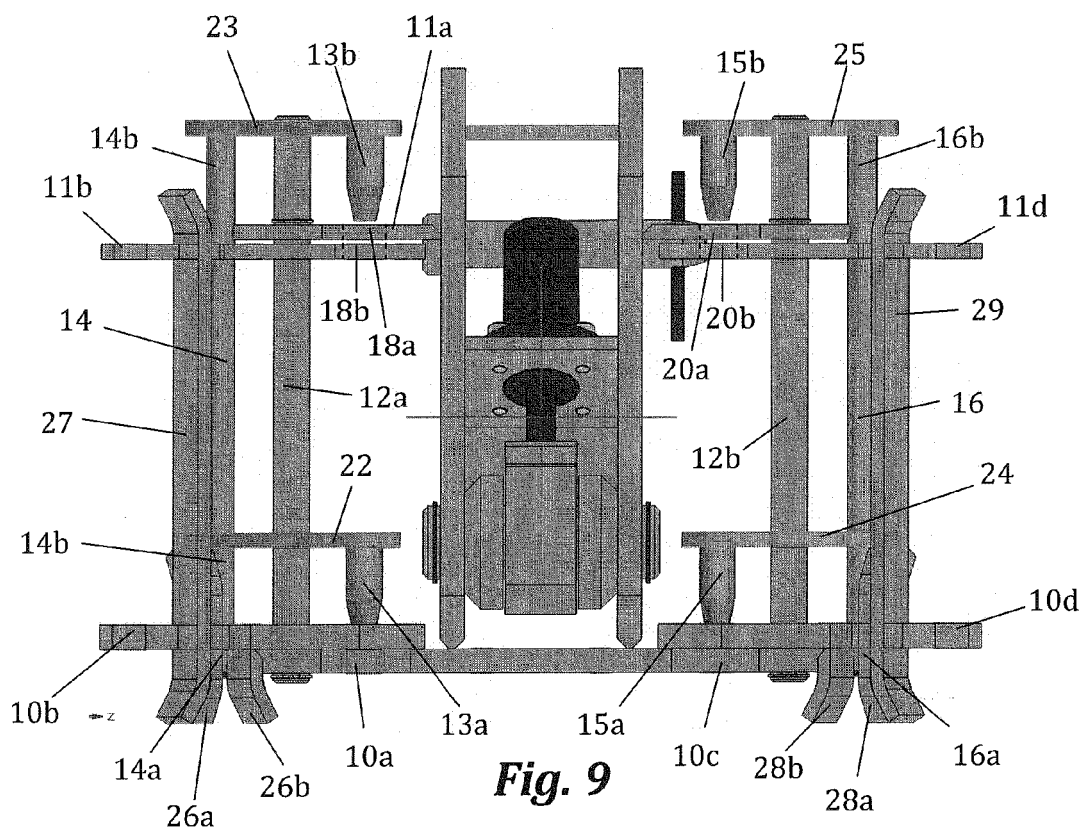


**Fig. 5**





**Fig. 8**



**Fig. 9**



EUROPEAN SEARCH REPORT

Application Number  
EP 11 38 2122

DOCUMENTS CONSIDERED TO BE RELEVANT			
Category	Citation of document with indication, where appropriate, of relevant passages	Relevant to claim	CLASSIFICATION OF THE APPLICATION (IPC)
A	WO 2007/036300 A1 (DOKA IND GMGH [AT]; PENEDER JOHANN [AT]) 5 April 2007 (2007-04-05) * pages 11-12; figure 3 * -----	1-14	INV. E04G21/32
A	WO 2008/126999 A1 (KUMKANG INDUSTRY CO LTD [KR]; HONG YOUNG-KUN [KR]) 23 October 2008 (2008-10-23) * pages 6-9; figure 4 * -----	1	
			TECHNICAL FIELDS SEARCHED (IPC)
			E04G
The present search report has been drawn up for all claims			
Place of search <b>Munich</b>		Date of completion of the search <b>30 September 2011</b>	Examiner <b>Saretta, Guido</b>
<b>CATEGORY OF CITED DOCUMENTS</b> X : particularly relevant if taken alone Y : particularly relevant if combined with another document of the same category A : technological background O : non-written disclosure P : intermediate document		T : theory or principle underlying the invention E : earlier patent document, but published on, or after the filing date D : document cited in the application L : document cited for other reasons ..... & : member of the same patent family, corresponding document	

2  
EPO FORM 1503 03 82 (P04C01)

**ANNEX TO THE EUROPEAN SEARCH REPORT  
ON EUROPEAN PATENT APPLICATION NO.**

EP 11 38 2122

This annex lists the patent family members relating to the patent documents cited in the above-mentioned European search report. The members are as contained in the European Patent Office EDP file on  
The European Patent Office is in no way liable for these particulars which are merely given for the purpose of information.

30-09-2011

Patent document cited in search report	Publication date	Patent family member(s)	Publication date
WO 2007036300 A1	05-04-2007	AT 502173 T	15-04-2011
		DE 102005045527 A1	19-04-2007
		EP 1929107 A1	11-06-2008
		ES 2362535 T3	07-07-2011
		HK 1123589 A1	03-06-2011
-----	-----	-----	-----
WO 2008126999 A1	23-10-2008	KR 100841011 B1	24-06-2008
-----	-----	-----	-----

**REFERENCES CITED IN THE DESCRIPTION**

*This list of references cited by the applicant is for the reader's convenience only. It does not form part of the European patent document. Even though great care has been taken in compiling the references, errors or omissions cannot be excluded and the EPO disclaims all liability in this regard.*

**Patent documents cited in the description**

- EP 1899548 A [0004]
- EP 1899549 A [0004]
- EP 1902185 A [0004]