

(19)



(11)

EP 2 522 403 A1

(12)

EUROPEAN PATENT APPLICATION

(43) Date of publication:
14.11.2012 Bulletin 2012/46

(51) Int Cl.:
A63B 22/02 (2006.01) **A63B 24/00 (2006.01)**
A63B 69/00 (2006.01) **A63B 71/06 (2006.01)**

(21) Application number: **11165490.1**

(22) Date of filing: **10.05.2011**

(84) Designated Contracting States:
AL AT BE BG CH CY CZ DE DK EE ES FI FR GB GR HR HU IE IS IT LI LT LU LV MC MK MT NL NO PL PT RO RS SE SI SK SM TR
Designated Extension States:
BA ME

(72) Inventors:
• **Schmitz, Micael**
343 21, ÄLMHULT (SE)
• **Johansson, Daniel**
343 21, ÄLMHULT (SE)

(71) Applicant: **MSE Weibull AB**
343 21 Älmhult (SE)

(74) Representative: **Simonsson, Erik**
Awapatent AB
Västra Esplanaden 9 A
Box 99
351 04 Växjö (SE)

(54) **A device for allowing a user to walk or run on the spot in an arbitrary direction and control method therefor**

(57) The invention concerns a device (1) for allowing a user (25) to walk or run on the spot in an arbitrary direction and a method for controlling the device (9). The device (1) comprises a stationary central platform (9) surrounded by a convex polygon shaped deck (6) in level therewith, said deck (6) being divided into trapezoid shaped roller conveyors. Each conveyor has rollers in parallel with the trapezoid bases, the shorter one of these adjoining said platform and the longer one of these form-

ing a side of said polygonal shape. The rollers of said conveyors are driven in order to move a user (25) stepping thereon back to said central platform (9). The rollers as such are continuous circular cylindrical, and beneath them there is a driving means for frictional driving engagement with the rollers from below. According to the method a marker (26) placed on top of the user (25) is monitored by means of video cameras (24) and the speed of the roller conveyors adjusted depending on the perceived marker size and position.

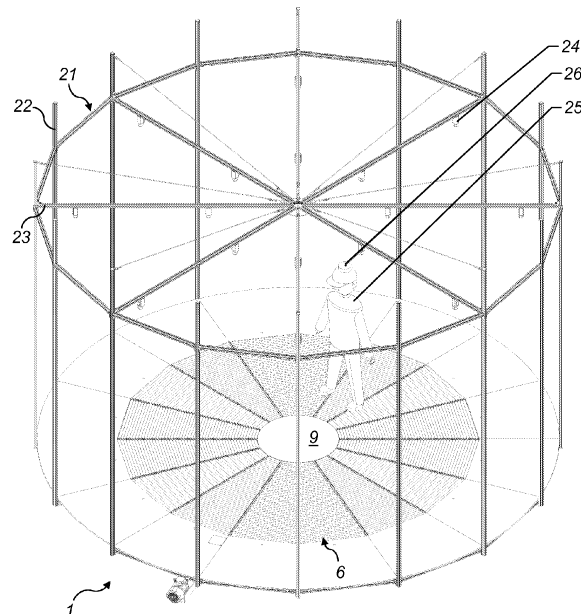

Fig. 6

EP 2 522 403 A1

DescriptionTechnical Field

[0001] The present invention concerns a device for allowing a user to walk or run on the spot in an arbitrary direction, the device comprising a stationary central platform surrounded by a convex polygon shaped deck in level therewith, said deck being divided into trapezoid shaped roller conveyors, wherein each conveyor has rollers in parallel with the trapezoid bases, the shorter one of these adjoining said platform and the longer one of these forming a side of said polygonal shape, and wherein the rollers of said conveyors are driven in order to move a user stepping thereon back to said central platform. Further, the present invention concerns a method of controlling such a device.

Prior Art

[0002] A device of the kind in question is previously known from the international application WO 96/35481 A2. In that application an embodiment of the device according to the preamble is revealed, comprising trapezoid roller conveyors having rollers divided into two equally long circular cylindrical parts with a central waist part in-between. Further revealed is a method of controlling the device according to the preamble based upon data from accelerometers provided on the user of the device.

[0003] The known device and method raise several concerns about safety. For one thing, the waist part of the rollers increases risk of a user's clothing getting entangled in a hazardous way, even if said waist part, as indicated, is partly covered by means of a countersunk cover strip. Furthermore, the accelerometers used for the known method are hardly of any use when it comes to detecting the user stumbling, which for safety reasons would necessitate an immediate halt of the conveyors in order to avoid risk of squeezing for instance a finger.

[0004] Then the known device has some practical drawbacks, too. The mounting of the rollers is rendered quite complicated by the way chosen to drive the rollers, regardless if a belt is used, encompassing the rollers and thus hampering their mounting or dismounting, or cog wheels are used, necessitating use of intermediate gears in order to get neighboring rollers rotate in the same and not opposite directions.

Object of the Invention

[0005] Against that background an object of the invention is to provide a device according to the preamble with improved trapezoid shaped roller conveyors. A further object of the invention is to devise a method of controlling the device in an advantageous way.

Short Summary of the Invention

[0006] According to the invention this is achieved in that the rollers of the device are continuous circular cylindrical, and in that beneath each conveyor there is a driving means for frictional driving engagement with said rollers from below. By choosing a friction drive solution instead the invention renders use of all smooth and continuously shaped rollers possible despite the trapezoid shape of the roller conveyors of the device. This facilitates not only the production and mounting of the trapezoid roller conveyors and their rollers, but also service measures, because for example no driving belts have to be dismantled in order to lift off a conveyor. Further the device according to the invention improves safety in that the roller conveyor surfaces become smoother and less rugged than before, thereby reducing risk of clothing entanglement or finger squeezing.

[0007] Said driving means preferably comprises an endless belt extending along the roller conveyor in frictional driving engagement with all rollers thereof. A solution like that is much easier to accomplish than other conceivable friction drive solutions, like individual rubber wheels for at least every second roller. However, that does not mean that solutions like that are not feasible as well.

[0008] Preferably the driving shafts of said driving means are interconnected by flexible joints and driven by a single motor. It is well known to use flexibel joints, also known as universal joints, to transmit a rotational movment around a corner, if the angle of that corner is within reasonable limits. Thus, in the device according to the invention one such joint may be used at every transition between two adjoining roller conveyors in order to transmit power from a single motor to all of the conveyors in minor angular steps that do not cause any blocking problems.

[0009] The deck of the device according to the invention is prefereably circumferentially enclosed by a stationary floor plate in level therewith. The floor plate marks the outer limits of the device and can be used as a safety retreat, for example if the speed of the roller conveyors of the device is to slow to carry the user back to the central platform.

[0010] Preferably said floor plate covers parts of said driving means. This is very advantageous, because it simplifies access to the driving means. Further, it makes it possible to minimise height of the device, because for example the preferred single motor, which has to be of considerable size, thus can be hidden below the rather thin floor plate instead of below a rather thick roller conveyor.

[0011] Preferably said driving means frictionally engages the conveyor rollers in a central part of these, said rollers being journalled at end parts thereof in resiliently mounted bearings. This solution is advantageous out of two reasons. The first one is that the roller conveyor by this measure become more pleasant to walk or run upon,

just like a slightly resilient sporting floor. The second one is that the resiliency assures good driving contact between the rolls of a conveyor and said driving means even if a user steps on rolls far from the central parts of these.

[0012] According to a preferred embodiment of the invention said deck is of regular convex polygon shape and its roller conveyors are of uniform isosceles trapezoid shape. A solution like that is the most advantageous one if a device is to be created allowing walking or running in arbitrary directions without any limits, which could be the case if the outer limits of some of the roller conveyors were close to the central platform while others were not.

[0013] The device according to the invention is preferably controlled by means of a method characterized by the following steps: mounting a plurality of video cameras above the device on a height well above a user thereof, said cameras being arranged in a defined matrix and directed downwardly; providing a direction indicating marker on top of said user; monitoring the position and size of said marker by means of said cameras; controlling the speed of the roller conveyors depending on said markers distance from said central platform as seen from above by said cameras at an elevated speed when said distance is large and at a lower speed when said distance is small; and halting the roller conveyors when said distance is nil. By using video cameras instead of accelerometers, like in the prior art device, the user only has to wear only a simple marker, e.g. on top of a cap or helmet, to get connected to the device. Thus, there is no need of wiring or fitting battery packs or the like, which enhances both convenience and safety. Further, by placing the marker on top of the user instead of on his arm or legs, which are moving to and fro while walking or running, monitoring of the users actual position and adapting the roller conveyor speed thereto becomes more safe and a lot easier.

[0014] The method according to the invention preferably comprises the further step of halting the roller conveyors when the size of said marker as seen from above by said cameras is substantially decreased or when the marker can no longer be seen at all by said cameras. This step marks another important safety feature, because it ensures that the roller conveyors of the device according to the invention come to an immediate halt should the user kneel or lie down or trip and fall or just lose the marker.

[0015] The method according to the invention preferably comprises the further steps of mounting video displays or screens, that can be viewed by the user, and of adapting the content shown on said video displays or screens to the speed of the roller conveyors, the actual position and size of said marker and to its direction. This makes it possible to greatly enhance the users overall perception in a virtual reality environment created by means of said video displays or screens. Further, according to a preferred embodiment the theme to be shown on said video displays or screens can be chosen depend-

ing on the type of marker used. This makes the device according to the invention more user friendly and adaptable, for instance by simply changing from one cap, having one type of marker thereon, to another cap, having another type of marker thereon.

[0016] The method according to the invention preferably comprises the further step of lowering the speed of the roller conveyors if the direction of the marker on top of the user indicates that the user, having stepped on the deck is facing in a non-radial direction in relation to the central platform. This step takes into consideration that a user, who for example turns his head while walking, usually slows his walking speed and therefor could become unbalanced if moved to fast by the roller conveyors of the device according to the invention.

Short Description of the Drawings

[0017] In the drawings a preferred embodiment of the device according to the invention is shown and a preferred embodiment of the method according to the invention illustrated, wherein:

Fig. 1 shows the preferred embodiment of the device according to the invention in a perspective view; Fig. 2 shows the device according to Fig. 1 from above; Fig. 3 shows portion A of Fig. 2 in greater detail with some parts broken away; Fig. 4 shows the device in a side view along section B-B in Fig. 2; Fig. 5 shows portion C of Fig. 4 in greater detail; and Fig. 6 shows, in a perspective view, a user of the device, the device itself and other means needed to perform the method according to the invention.

Description of a Preferred Embodiment

[0018] The device 1 according to the preferred embodiment of the invention is generally circular when seen from above. The circle periphery is created by a horizontal ringshaped floor plate 2, which by radial lines is divided into several sectors 3. In total there are sixteen identical floor sectors 3, all of them resting on a framing structure 4 including radial beams 5 underneath the division lines. The framing structure 4 with its radial beams 5 is best seen in Fig. 3, where two floor sectors 3 are removed to reveal the substructure of the device 1. At the inner circumference of the ringshaped floor plate 2 each floor sector 3 forms a line, that runs straight from one of the division lines to the next. This makes the sixteen floor sectors 3 create a regular hexadecagon shaped ring opening.

[0019] Inside of the ring opening of the ring shaped floor plate 2 a horizontal deck 6 is provided in level with the floor plate 2. The deck 6 too is ring shaped and concentric with the floor plate 2. The deck 6 consists of a total of sixteen identical roller conveyors 7, each one of

an isosceles trapezoid shape with rollers 8 in parallel with the trapezoid bases. The sixteen roller conveyors 7 are radially aligned each with one of the sixteen floor sectors 3 and connect to these without any major interruption each with a roller 8 along the longer baseline of the roller conveyor 7 in question. The opposite rollers 8 along the shorter baselines of the roller conveyors 7 define a regular hexadecagon shaped opening, which forms the inner circumference of the deck 6.

[0020] Finally, inside of the ring opening of the ring shaped deck 6 a horizontal central platform 9 is provided in level with both the floor plate 2 and the deck 6. The platform 9 is stationary and has the shape of a regular hexadecagon and a size that fits the inner circumference of the deck 6 without leaving any major interruption. Like the floor plate 2 the central platform 9 is resting on said framing structure 4, which has its radial beams 5 running all the way into the center of the circular device 1.

[0021] The deck 6 is also resting on the framing structure 4, however not directly on the radial beams 5 but, as can be seen in the detailed view in Fig. 5, on resilient elastomer strips 10 mounted on top of these. On said strips 10 side boards 11 of the roller conveyors 7 rest. The side boards 11 are kept in place by means of studs 12 which are attached to the radial beams 5 and freely pass orifices in said side boards 11, thus enabling some suspended side board movement within limits given by heads of the studs 12 protruding on top of said orifices.

[0022] The rollers 8 of the roller conveyors 7 are journaled in bearings 13 held by said side boards 11 and mounted as close as possible to each other without touching each other both in parallel within one and the same roller conveyor 7 as well as sideways between two roller conveyors 7 adjoining on top of a radial beam 5 of said frame structure 4. Thus, the rollers 8 would be freely rotatable if there was not a driving means 14 arranged underneath them in frictional contact with each of them.

[0023] As can be seen in Fig. 3, according to the preferred embodiment of the invention the driving means 14 for every roller conveyor 7 comprises an endless belt 15. The belt 15 extends radially towards the center of the device 1, centrally in relation to the roller conveyor 7 in question. By means of a sliding support 16 under the upper course of each endless belt 15 these courses are pushed into frictional engagement with all rollers 8 of the roller conveyors 7, wherein the resilient suspension of the roller conveyors 7 ensures perfect belt-roller contact even in situations where the rollers 8 are loaded eccentrically.

[0024] Each one of the endless belts 15 runs about end pulleys 16, 17, of which preferably the inner one 16 is a idling pulley and the outer one 17 is a driving pulley. Further, the driving pulleys 17 are driven by means of a cardan shaft arrangement 18, that comprises flexible joints 19 on both sides of the driving pulleys 17 and runs from a single electric motor 20 to a first driving pulley 17 and from there to the next driving pulley 17, and so on.

[0025] As can be seen best in Fig. 3, the cardan shaft

arrangement 18 is well hidden below the floor plate 2 and yet easily accessible by simple removal of chosen floor sectors 3. The same goes for the roller conveyors 7, which are fairly easy to remove thanks to the fact that they are frictionally driven and thus can be lifted off easily once the securing studs 12 are removed.

[0026] In Fig. 6 the device 1 according to the preferred embodiment described above is shown together with some extra features provided in order to render a method of controlling the device 1 possible. In Fig. 6 the previous reference numbers are mostly omitted, because the perspective view of the device 1 as such is identical with the one in Fig. 1.

[0027] Besides device 1 the arrangement in Fig. 6 comprises a cage 21, that surrounds the device 1. The cage 21 has erect post 22 and a roof comprising diagonally extending rails 23. The posts 22 are preferably used to mount video displays or screens (not shown) that enable creation of a per se known virtual reality environment. The rails 23 carry video cameras 24, which are directed downwardly. As can be seen the video cameras 24 are arranged in a well defined matrix at a height well above a user 25 of the device 1. The user wears a cap on top of which there is a marker 26 of a defined pattern that is direction indicating.

[0028] In the method according to the invention the video cameras 24 track the position of the marker 26, the size thereof and its direction and use that information in order to decide where the user 25 of the device 1 presently is and where he is heading or facing. If the user is not in the center of the device 1 on the stationary platform 9 or leaves the platform 9, the electric motor 20 is activated in order to drive the roller conveyors 7 and make them return the user 25 stepping thereon to the platform 9. According to the method the speed with which the user 25 is returned to the stationary platform 9 is higher the further away the user 25 is from the platform, which means too that speed is lowered once the user 25 comes close to or is close to the stationary platform 9. Once the user 25 is back on the stationary platform 9, the electric motor 20 is again stopped and thus the roller conveyors 7 halted. In the method according to the invention they are halted as well if the marker 26 on top of the user 25 becomes obscured or no longer is detectable, which can be due to the user 25 stumbling and falling or stepping past the deck 6 and onto the floor plate 4, or due to the marker 26 coming off for some reason. Further, a detected change of perceived size of the marker 26, which can be due to the user 25 kneeling or lying down, can be used as an indicator to immediately stop the roller conveyors 7 for safety reasons.

[0029] In a more advanced control mode based upon the method according to the invention the speed of the roller conveyors 7 is based on the position of the user 25 relative to the central platform 9 with thereto optionally derivating elements to account for the time over which user positional changes occur and adapt the speed of the roller conveyors 7 accordingly, and integrating ele-

ments to allow faster maximum conveyor speeds over time.

[0030] The method according to the invention can comprise the further steps of mounting video displays or screens (not shown), that can be viewed by the user 25, and of adapting the content, that is the viewing angle or the moving speed, of the content shown on said video displays or screens to the speed of the roller conveyors 7, the actual position and size of said marker 26 and to its direction. Further, it is well possible to chose the theme to be shown on said video displays or screens in dependence on the type of marker 26 used, such as a marker 26 on military helmet for initiating a combat scene or a marker 26 on a station-master cap for initiating a train platform scene.

[0031] Finally, the method according to the invention can further comprise the the step of lowering the speed of the roller conveyors 7 if the direction of the marker 26 on top of the user 25 indicates that the user 25, having stepped on the deck 6 is facing in a non-radial direction in relation to the central platform 9. This takes into consideration the fact that a user 25, who turns his head while walking, usually slows his walking speed and therefore could become unbalanced if moved to fast by the roller conveyors 7 of the device 1 according to the invention.

Claims

1. A device (1) for allowing a user (25) to walk or run on the spot in an arbitrary direction, the device (1) comprising a stationary central platform (9) surrounded by a convex polygon shaped deck (6) in level therewith, said deck (6) being divided into trapezoid shaped roller conveyors (7), wherein each conveyor (7) has rollers (8) in parallel with the trapezoid bases, the shorter one of these adjoining said platform (9) and the longer one of these forming a side of said polygonal shape, and wherein the rollers (8) of said conveyors (7) are driven in order to move a user (25) stepping thereon back to said central platform (9),
characterized in that said rollers (8) are continuous circular cylindrical, and
that beneath each conveyor (7) there is a driving means (14) for frictional driving engagement with said rollers (7) from below.
2. The device (1) according to claim 1, in which said driving means (14) comprises an endless belt (15) extending along the roller conveyor (7) in frictional driving engagement with all rollers (8) thereof.
3. The device (1) according to claim 1 or 2, in which driving shafts (18) of said driving means (14) are interconnected by flexible joints (19) and driven by a single motor (20).

4. The device (1) according to any one of the previous claims, in which said deck (16) is circumferentially enclosed by a stationary floor plate (2) in level therewith.
5. The device (1) according to claim 4, in which said floor plate (2) covers parts of said driving means (14).
6. The device (1) according any one of the previous claims, in which said driving means (14) frictionally engages the conveyor rollers (8) in a central part of these, said rollers (8) being journalled at end parts thereof in resiliently mounted bearings (13).
7. The device (1) according to any one of the previous claims, in which said deck (16) is of regular convex polygon shape and its roller conveyors (7) are of uniform isosceles trapezoid shape.
8. A method of controlling a device (1) according to any one of the previous claims, **characterized by** the following steps:
mounting a plurality of video cameras (24) above the device (1) on a height well above a user (25) thereof, said cameras (24) being arranged in a defined matrix and directed downwardly;
providing a direction indicating marker (26) on top of said user (25),
monitoring the position and size of said marker (26) by means of said cameras (24);
controlling the speed of the roller conveyors (7) depending on said marker's (26) distance from said central platform (9) as seen from above by said cameras (24) at an elevated speed when said distance is large and at a lower speed when said distance is small; and
halting the roller conveyors (7) when said distance is nil.
9. The method according to claim 8, further comprising the step of halting the roller conveyors (7) when the size of said marker (26) as seen from above by said cameras (24) is substantially decreased or when the marker (26) can no longer be seen at all by said cameras (24).
10. The method according to claim 8 or 9, further comprising the steps of mounting video displays or screens, that can be viewed by the user (25), and of adapting the content shown on said video displays or screens to the speed of the roller conveyors (7), the actual position and size of said marker (26) and to its direction.
11. The method according to claim 10, further comprising the step of choosing the theme to be shown on said video displays or screens depending on the type

of marker (26) used.

12. The method according to any one of claims 8-11, further comprising the step of lowering the speed of the roller conveyors (7) if the direction of the marker (26) on top of the user (25) indicates that the user (25), having stepped on the deck (6) is facing in a non-radial direction in relation to the central platform (9).

5

10

15

20

25

30

35

40

45

50

55

6

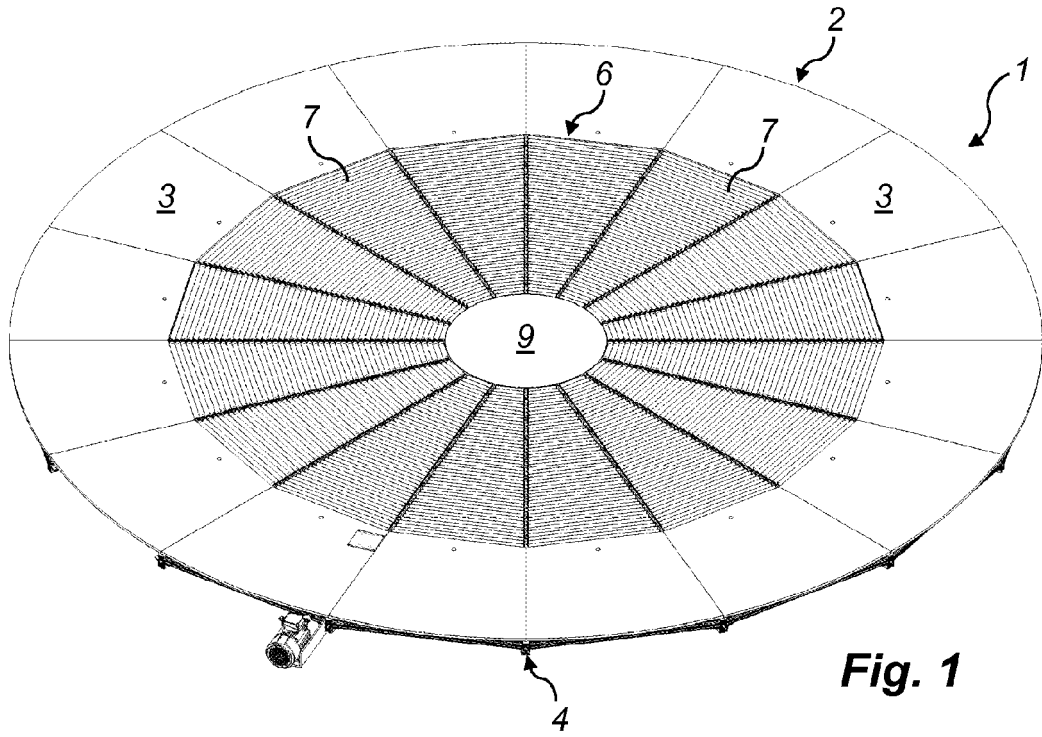

Fig. 1

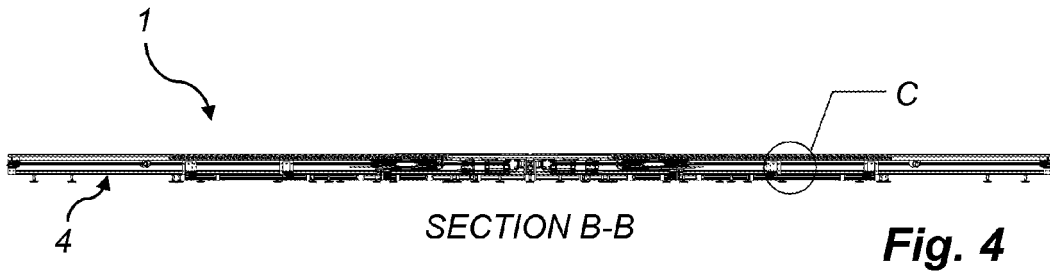
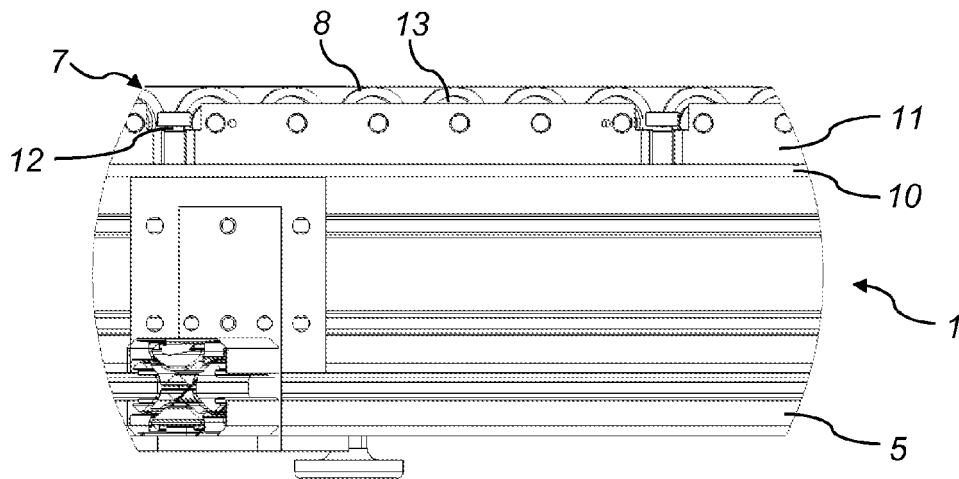

Fig. 4



DETAIL C

Fig. 5

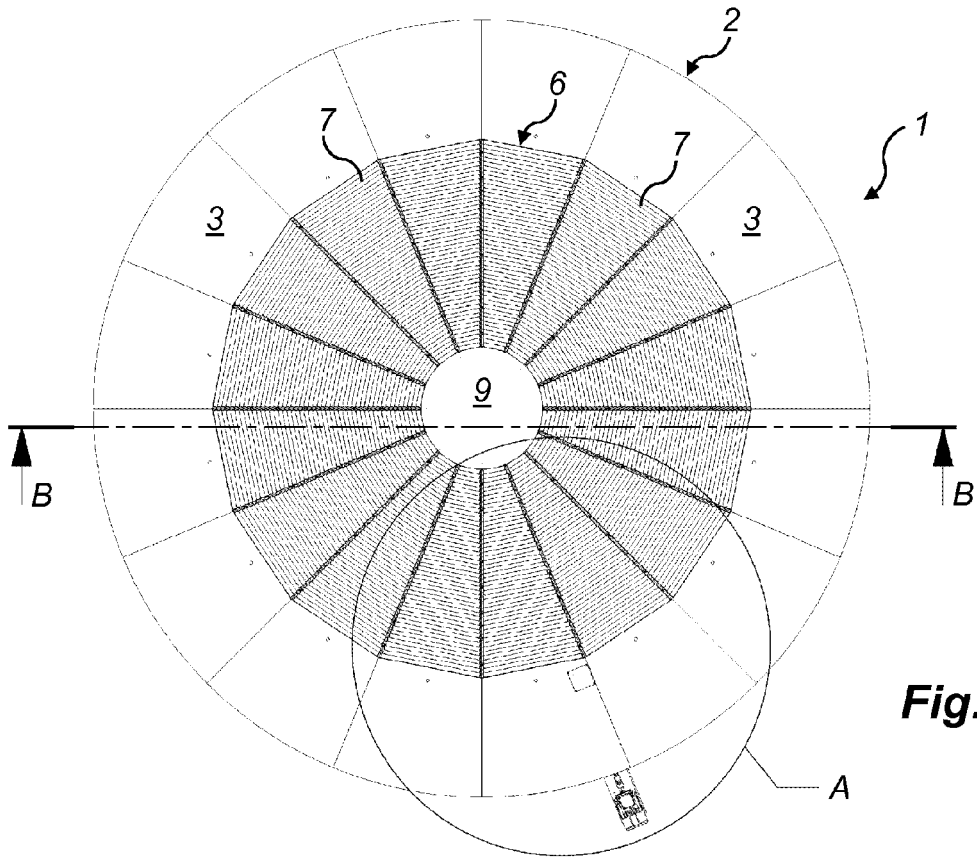

Fig. 2

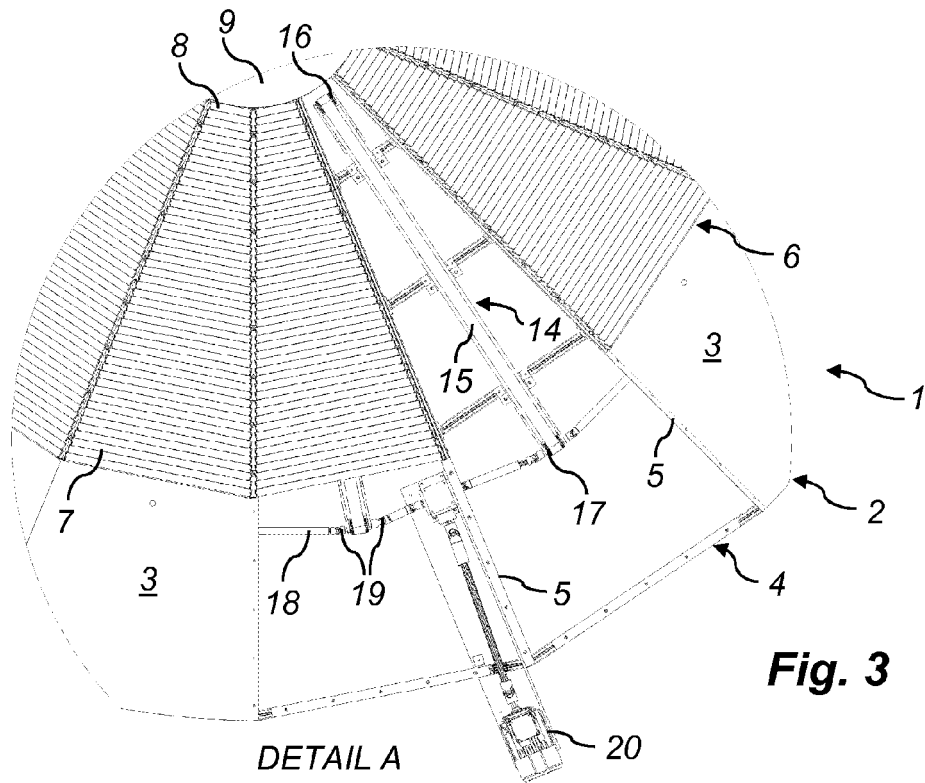

Fig. 3

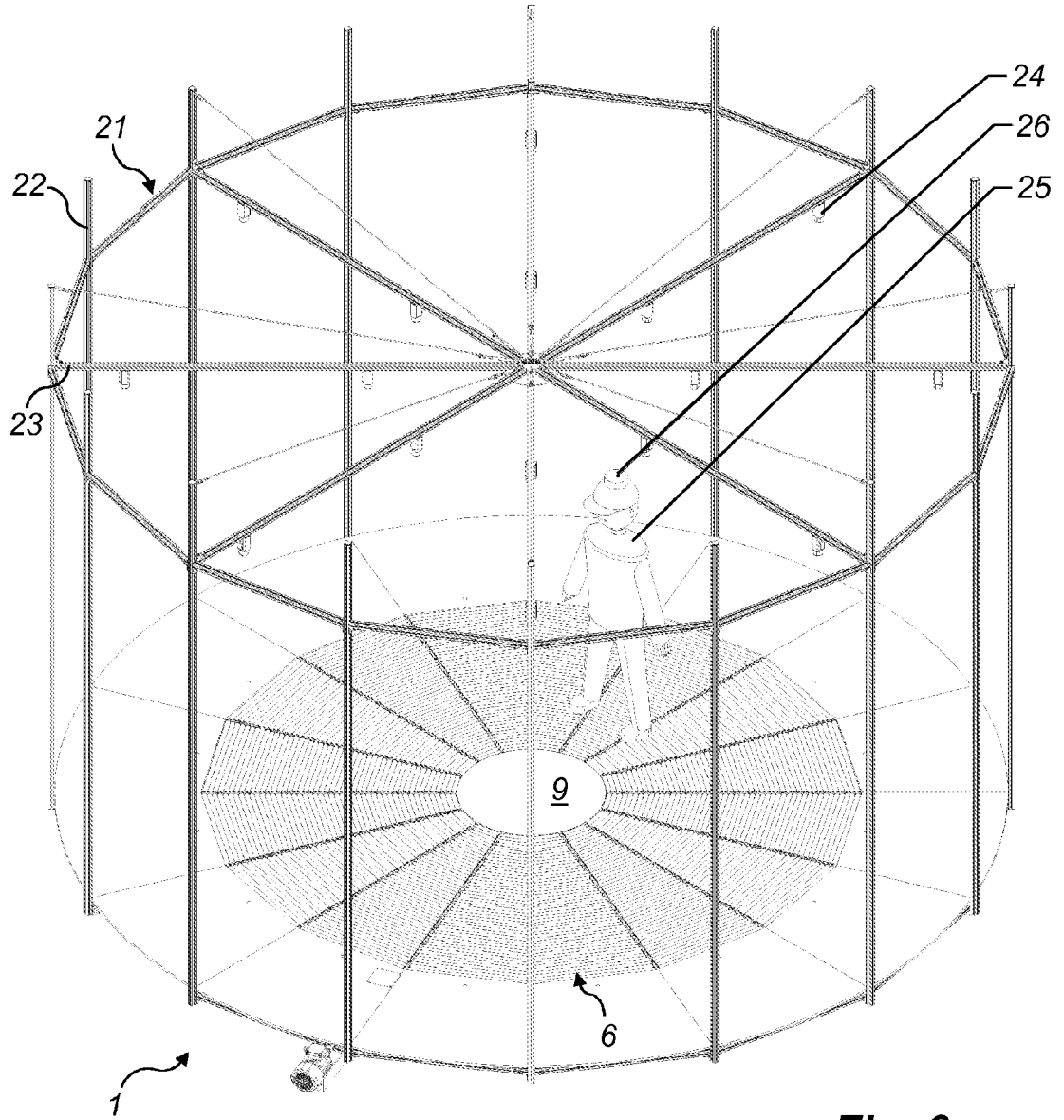

Fig. 6

**ANNEX TO THE EUROPEAN SEARCH REPORT
ON EUROPEAN PATENT APPLICATION NO.**

EP 11 16 5490

This annex lists the patent family members relating to the patent documents cited in the above-mentioned European search report. The members are as contained in the European Patent Office EDP file on
The European Patent Office is in no way liable for these particulars which are merely given for the purpose of information.

05-10-2011

Patent document cited in search report	Publication date	Patent family member(s)	Publication date
WO 9635481 A2	14-11-1996	DE 29507690 U1	03-08-1995
DE 102004016429 A1	20-10-2005	NONE	
US 7399258 B1	15-07-2008	NONE	
WO 2010089618 A2	12-08-2010	NONE	
US 6152854 A	28-11-2000	NONE	

EPO FORM P0469

For more details about this annex : see Official Journal of the European Patent Office, No. 12/82

REFERENCES CITED IN THE DESCRIPTION

This list of references cited by the applicant is for the reader's convenience only. It does not form part of the European patent document. Even though great care has been taken in compiling the references, errors or omissions cannot be excluded and the EPO disclaims all liability in this regard.

Patent documents cited in the description

- WO 9635481 A2 [0002]