



(11) **EP 2 524 740 A1**

(12) **EUROPEAN PATENT APPLICATION**

(43) Date of publication:
21.11.2012 Bulletin 2012/47

(51) Int Cl.:
B21D 5/06 (2006.01) B21D 22/02 (2006.01)
B21D 22/22 (2006.01) B21D 53/88 (2006.01)

(21) Application number: **11166738.2**

(22) Date of filing: **19.05.2011**

(84) Designated Contracting States:
AL AT BE BG CH CY CZ DE DK EE ES FI FR GB GR HR HU IE IS IT LI LT LU LV MC MK MT NL NO PL PT RO RS SE SI SK SM TR
Designated Extension States:
BA ME

(72) Inventors:
• **Tanaka, Yasuharu**
Tokyo 100-8071 (JP)
• **Miyagi, Takashi**
Tokyo 100-8071 (JP)
• **Ogawa, Misao**
Tokyo 100-8071 (JP)
• **Uchiyama, Shigeru**
Tokyo 100-8071 (JP)

(71) Applicant: **Nippon Steel Corporation**
Chiyoda-ku
Tokyo
100-8071 (JP)

(74) Representative: **Vossius & Partner**
Siebertstrasse 4
81675 München (DE)

(54) **Press-forming method of component having L shape**

(57) A forming method of a press component having an L shape for forming a component having a top sheet section and a vertical wall section, which is connected to the top sheet section with a bent section having a part curved in an arc shape and has a flange section on the opposite side to the bent section, the top sheet section being on the outside of the arc of the vertical wall section,

from a blank metal sheet, includes: disposing the blank metal sheet between a die or a pad and a bending die; and in a state where the pad is caused to approach or come in contact with the blank metal sheet, forming the vertical wall section and the flange section while at least a part of the blank metal sheet is caused to slide on a part of the die corresponding to the top sheet section.

FIG. 1

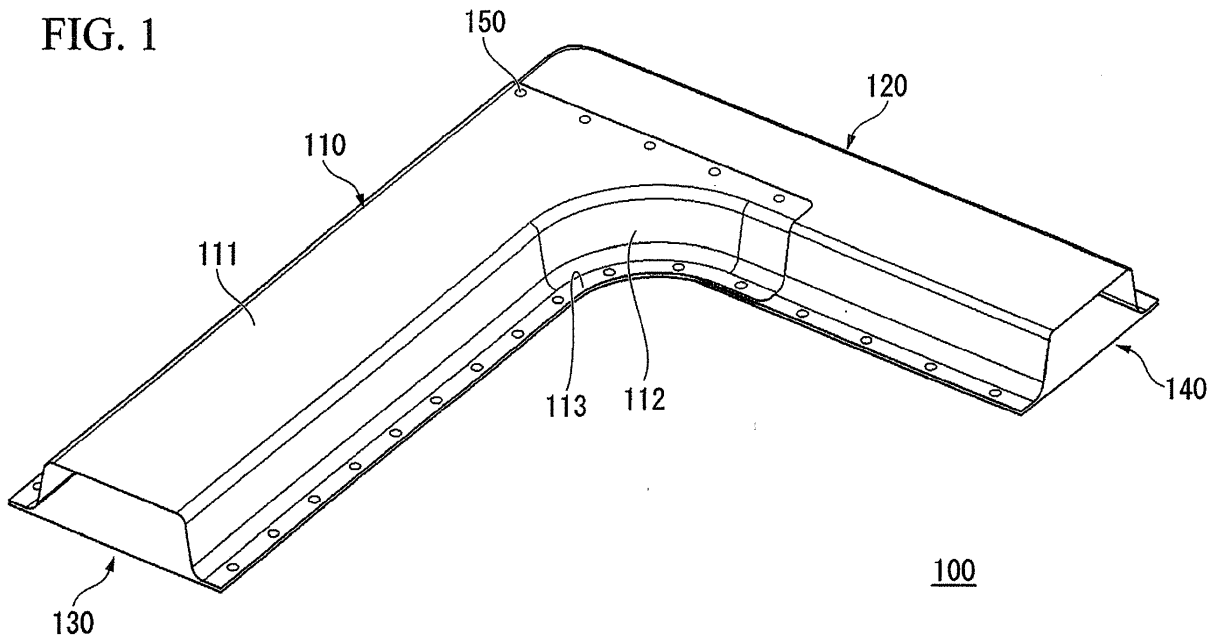

EP 2 524 740 A1

Description

BACKGROUND OF THE INVENTION

5 Field of the Invention

[0001] The present invention relates to a press-forming method of a component having an L shape used as a framework member or the like of an automobile.

10 Description of Related Art

[0002] An automobile framework structure is formed by joining framework members such as a front pillar reinforcement, a center pillar reinforcement, or a side sill outer reinforcement manufactured by press-forming a blank metal sheet. For example, FIG. 1 shows a framework structure 100 formed by joining framework members 110, 120, 130, and 140 using spot welding. The framework member 110 has an L shape including a top sheet section 111, a vertical wall section 112, and a flange section 113, thereby ensuring strength and rigidity of the framework structure 100.

[0003] In general, when a component having an L shape (hereinafter, sometimes called an L-shaped component) such as the framework member 110 is press-formed, a drawing method is employed in order to suppress generation of wrinkles. In the drawing method, as shown in (a) and (b) of FIG. 3, a blank metal sheet 300A is drawn into a formed body 300B using a die 201, a punch 202, and a blank holder 203 (holder). For example, when a component 300 shown in FIG. 4A is manufactured by the drawing method, (1) the blank metal sheet 300A shown in FIG. 4B is installed between the die 201 and the punch 202, (2) a clamped area T in the periphery of the blank metal sheet 300A shown in FIG. 4C is strongly clamped by the blank holder 203 and the die 201, (3) the blank metal sheet 300A is drawn into a drawn body 300B shown in FIG. 4D by relatively moving the die 201 and the punch 202 in a press direction (vertical direction), and (4) unnecessary portions of the periphery of the drawn body 300B are trimmed, thereby obtaining the component 300. By the drawing method, a flow of a metal material of the blank metal sheet 300A can be controlled by the blank holder 203, and therefore generation of wrinkles due to an excessive inflow of the blank metal sheet 300A can be suppressed. However, since a large trim area is needed in the periphery of the blank metal sheet 300A, the yield is reduced, resulting in an increase in costs. In addition, during the drawing, in the drawn body 300B, as shown in FIG. 5, wrinkles are more likely to be generated in an area (α area) into which the metal material excessively flows, and cracks are more likely to be generated in an area (β area) in which the thickness is locally reduced. In order to prevent such cracks and wrinkles, typically, a metal sheet having excellent ductility and relatively low strength needs to be used as the blank metal sheet 300A.

[0004] As described above, a blank metal sheet to be drawn requires high ductility. For example, when a steel sheet having small ductility and high strength is used as the blank metal sheet to draw an L-shaped component, cracks or wrinkles are likely to be generated due to insufficient ductility. Accordingly, typically, the L-shaped component such as a front pillar reinforcement or a center pillar reinforcement is manufactured using a steel sheet having excellent ductility and relatively low strength as the blank metal sheet. Therefore, in order to ensure strength, the thickness of the blank metal sheet needs to be high, so that there is a problem with increases in component weight and costs. Such a problem also occurs when a framework member 110' having a T shape is press-formed by combining two L shapes as shown in FIG. 2.

[0005] In JP-A-2003-103306, JP-A-2004-154859, JP-A-2006-015404, and JP-A-2008-307557, bend-forming methods for manufacturing components having simple cross-sectional shapes such as a hat shape or a Z shape are described. However, such methods cannot be used for manufacturing the L-shaped component.

45 SUMMARY OF THE INVENTION

[0006] In consideration of the problem, an object of the invention is to provide a press-forming method of a component having an L shape, the method being capable of press-forming a component having an L shape from a blank metal sheet with high yield even though a high-tensile material with low ductility and high strength is used for the blank metal sheet.

[0007] In order to accomplish the object, the invention uses the following methods.

(1) According to a first aspect of the invention, there is provided a forming method of a press component having an L shape for forming a component having a top sheet section and a vertical wall section, which is connected to the top sheet section with a bent section having a part curved in an arc shape and has a flange section on the opposite side to the bent section, the top sheet section being on the outside of the arc of the vertical wall section, from a blank metal sheet, including: disposing the blank metal sheet between a die or a pad, and a bending die; and in a

state where the pad is caused to approach or come in contact with the blank metal sheet, forming the vertical wall section and the flange section while at least a part of the blank metal sheet is caused to slide on a part of the die corresponding to the top sheet section.

5 (2) In the forming method of a press component having an L shape described in (1), in the forming of the vertical wall section and the flange section, a part of the metal sheet may be pressurized as an out-of-plane deformation suppressing area by the pad.

10 (3) In the forming method of a press component having an L shape described in (1), in the forming of the vertical wall section and the flange section, a portion of the metal sheet that approaches or comes in contact with an out-of-plane suppressing area of the pad as the out-of-plane deformation suppressing area may be formed in a state where a clearance between the pad and the die is equal to or greater than the thickness of the blank metal sheet and is maintained to be equal to or smaller than 1.1 times the thickness of the blank metal sheet.

15 (4) In the forming method of a press component having an L shape described in (2) or (3), the out-of-plane deformation suppressing area may be, in a first end portion which is one end portion of the part curved in the arc shape of the bent section when viewed in a direction perpendicular to a surface of the top sheet section, from an area of the top sheet section halved by a tangent line of a boundary line between the bent section and the top sheet section, an area of the blank metal sheet which abuts on the part of the die corresponding to the top sheet section on a side including a second end portion which is the other end portion of the part curved in the arc shape of the bent section.

20 (5) In the forming method of a press component having an L shape described in any one of (2) to (4), in the end portion of the blank metal sheet, from the part of the blank metal sheet corresponding to the out-of-plane deformation suppressing area of the blank metal sheet, a portion which becomes the end portion of the part further on the top sheet side than the bent section may be on the same plane as the top sheet section.

(6) In the forming method of a press component having an L shape described in any one of (1) to (5), the top sheet section may have an L shape, a T shape, or a Y shape.

25 (7) In the forming method of a press component having an L shape described in any one of (1) to (6), a height of the vertical wall section may be equal to or greater than 0.2 times a length of the part curved in the arc shape of the bent section, or equal to or greater than 20 mm.

30 (8) In the forming method of a press component having an L shape described in any one of (1) to (7), in a part of the top sheet section in the blank metal sheet, which abuts on a boundary line between the top sheet section and the part curved in the arc shape of the bent section, an area within at least 5 mm from the boundary line may be caused to approach or come in contact with the pad.

35 (9) In the forming method of a press component having an L shape described in any one of (4) to (8), in the flange section, in a portion of the vertical wall section connected to the part curved in the arc shape of the bent section, widths of a flange portion of the first end portion side from a center portion in a longitudinal direction of the flange of the portion connected to the opposite side to the top sheet section and a flange portion in front of the flange portion of the first end portion side by 50 mm or greater may be equal to or greater than 25 mm and equal to or smaller than 100 mm.

40 (10) In the forming method of a press component having an L shape described in any one of (1) to (9), a radius of curvature of a maximum curvature portion of the boundary line between the part curved in the arc shape of the bent section and the top sheet section may be equal to or greater than 5 mm and equal to or smaller than 300 mm.

(11) In the forming method of a press component having an L shape described in any one of (1) to (10), a pre-processed blank metal sheet may be press-formed as the blank metal sheet.

45 (12) In the forming method of a press component having an L shape described in any one of (1) to (11), a blank metal sheet having a breaking strength of equal to or higher than 400 MPa and equal to or lower than 1,600 MPa may be used as the blank metal sheet.

(13) According to a second aspect of the invention, there is provided a forming method of a press component having an L shape, including: performing forming by the method according to any one of (1) to (12) to form a shape of a single L character, a shape of a plurality of L characters, or a shape of any L character, when a shape having a plurality of L characters is press-formed.

50 (14) According to a third aspect of the invention, there is provided a forming method of a press component having an L shape, for forming an L shape which has a vertical wall section, a flange section connected to one end portion of the vertical wall section, and a top sheet section that is connected to an end portion of the vertical wall section on the opposite side to a side connected to the flange section and extends in the opposite direction to the flange section and in which a part or the entirety of the vertical wall section is curved so that the flange section is on the inside, by pressing a blank metal sheet, including: performing forming by disposing a blank metal sheet having a shape in which an end portion of a part of the blank metal sheet corresponding to a lower side of the L shape is inside the top sheet section, on a die, and pressing the vertical wall section and the flange section with a bending die while pressing the top sheet section with a pad.

55 (15) In the forming method of a press component having an L shape described in (14), a width of the flange section

on the upper side from the center of the curve of the vertical wall section may be equal to or greater than 25 mm and equal to or smaller than 100 mm.

(16) According to a fourth aspect of the invention, there is provided a forming method of a press component having an L shape, for forming an L shape which has a vertical wall section, a flange section connected to one end portion of the vertical wall section, and a top sheet section that is connected to an end portion of the vertical wall section on the opposite side to a side connected to the flange section and extends in the opposite direction to the flange section and in which a part or the entirety of the vertical wall section is curved so that the flange section is on the inside, by pressing a blank metal sheet, including: disposing the blank metal sheet having a shape in which an end portion of a part of the blank metal sheet corresponding to the lower side of the L shape is inside the top sheet section, a margin thickness is provided in the flange section on the upper side from the center of the curve of the vertical wall section, and the sum of the thickness of the flange section and the margin thickness is equal to or greater than 25 mm and equal to or smaller than 100 mm, on a die; performing forming by pressing the vertical wall section and the flange section with a bending die while pressing the top sheet section with a pad; and trimming the margin thickness of the flange section.

(17) In the forming method of a press component having an L shape described in (16), a radius of curvature of a maximum curvature portion of the curve of the vertical wall section may be equal to or greater than 5 mm and equal to or smaller than 300 mm.

(18) In the forming method of a press component having an L shape described in (16) or (17), a pre-processed blank metal sheet may be press-formed as the blank metal sheet.

(19) In the forming method of a press component having an L shape described in any one of (16) to (18), a steel sheet having a breaking strength of equal to or higher than 400 MPa and equal to or lower than 1,600 MPa may be used as the blank metal sheet.

(20) According to a fifth aspect of the invention, there is provided a forming method of a press component having an L shape, including: performing forming by the method according to any one of (16) to (19) to form a shape of a single L character, a shape of a plurality of L characters, or a shape of any L character, when a shape having a plurality of L characters is press-formed.

[0008] According to the invention, when the component having the L shape (L-shaped component) is press-formed from the blank metal sheet, a part of the blank metal sheet corresponding to the lower side portion of the L shape of the L-shaped component is drawn toward the vertical wall section. As a result, in the flange section in which cracks are more likely to be generated due to a reduction in the thickness of the sheet during typical drawing, excessive drawing of the member is reduced, so that generation of cracks is suppressed. In addition, in the top sheet section in which wrinkles are more likely to be generated due to an inflow of an excessive metal material during typical drawing, the member is drawn, so that generation of wrinkles is suppressed.

[0009] In addition, since a large trim area for blank holding does not need to be provided in the part of the blank metal sheet corresponding to the lower side portion of the L shape of the L-shaped component, unlike a typical forming method, the area of the blank metal sheet can be reduced, thereby enhancing the yield. Moreover, since ductility needed by the blank metal sheet for forming is reduced, in addition to a steel sheet which has excellent ductility and relatively low strength and is thus typically used, a steel sheet having relatively low ductility and high strength can be used as the blank metal sheet. Accordingly, the thickness of the blank metal sheet can be reduced, thereby contributing to a reduction in weight of the automobile.

BRIEF DESCRIPTION OF THE DRAWINGS

[0010]

FIG 1 is a perspective view showing a framework structure 100 including a framework member 110 having an L shape.

FIG. 2 is a perspective view showing a framework member 110' having a T shape.

FIGS. 3 is an explanatory view of a drawing method.

FIG 4A is a perspective view showing a component 300 obtained by the drawing method.

FIG. 4B is a perspective view showing a blank metal sheet 300A which is to be formed into the component 300.

FIG. 4C is a perspective view showing a clamped area T in the periphery of the blank metal sheet 300A.

FIG 4D is a perspective view showing a formed body 300B obtained by drawing the blank metal sheet 300A.

FIG. 5 is a perspective view showing α portions in which wrinkles are more likely to be generated and β portions in which cracks are more likely to be generated in the formed body 300B.

FIG. 6 is a perspective view of an L-shaped component 10 obtained by a press component forming method according to an embodiment of the invention.

FIG. 7 is a schematic diagram of a die unit 50 used for the press component forming method according to the

embodiment of the invention.

FIG. 8 is a schematic view showing a press forming process performed by the die unit 50 used in the press component forming method according to the embodiment of the invention.

FIG. 9A is a diagram showing a steel sheet S used in the press component forming method according to the embodiment of the invention.

FIG. 9B is a perspective view showing a state where the steel sheet S is installed on a die 51.

FIG. 9C is a perspective view showing a state where the steel sheet S is formed into the L-shaped component 10.

FIG. 10 is a diagram showing an out-of-plane deformation suppressing area (area F) of the steel sheet S as a hatched section.

FIG. 11 is a diagram for explaining formed bodies in Examples 1 to 3 and 41 to 52.

FIG. 12 is a diagram for explaining a formed body in Example 4.

FIG. 13 is a diagram for explaining a formed body in Example 5.

FIG. 14 is a diagram for explaining a formed body in Example 6.

FIG. 15 is a diagram for explaining a formed body in Example 7.

FIG. 16 is a diagram for explaining a formed body in Example 8.

FIG. 17 is a diagram for explaining a formed body in Example 9.

FIG. 18 is a diagram for explaining a formed body in Example 10.

FIG. 19 is a diagram for explaining a formed body in Example 11.

FIG. 20 is a diagram for explaining a formed body in Example 12.

FIG. 21 is a diagram for explaining a formed body in Example 13.

FIG. 22 is a diagram for explaining formed bodies in Examples 14 to 17.

FIG. 23 is a diagram for explaining formed bodies in Examples 18 to 20.

FIG. 24 is a diagram for explaining a formed body in Example 21.

FIG. 25 is a diagram for explaining a formed body in Example 22.

FIG. 26 is a diagram for explaining a formed body in Example 23.

FIG. 27 is a diagram for explaining formed bodies in Examples 24 to 28.

FIG. 28 is a diagram for explaining formed bodies in Examples 29 to 32.

FIG. 29 is a diagram for explaining formed bodies in Examples 33 to 36.

FIG. 30 is a diagram for explaining formed bodies in Examples 37 to 38.

FIG. 31 is a diagram for explaining a formed body in Example 39.

FIG. 32 is a diagram for explaining a formed body in Example 40.

FIG. 33 is a diagram showing the shape of a pre-processed metal sheet used in Examples 37 and 38.

DETAILED DESCRIPTION OF THE INVENTION

[0011] Hereinafter, a press-forming method according to an embodiment of the invention will be described in detail.

[0012] In the press-forming method according to this embodiment, a component having a top sheet section 11, and a vertical wall section 12 which is connected to the top sheet section 11 with a bent section 15 having a part 15a curved in an arc shape and has a flange section 13 on the opposite side to the bent section 15, is formed of a steel sheet (a blank metal sheet). The top sheet section 11 exists on the outside of the arc of the vertical wall section 12. In this press-forming method, the vertical wall section 12 and the flange section 13 are formed in a state where sliding (in-plane movement) of at least a part of the area of the steel sheet S (at least a part of the area of the steel sheet S corresponding to the top sheet section 11) is allowed on a part of a die 51 corresponding to the top sheet section 11. More specifically, the steel sheet S is disposed between the die 51 or a pad 52 and a bending die 53, and in a state where the pad 52 is caused to approach or come in contact with the steel sheet S, the vertical wall section 12 and the flange section 13 are formed while at least a part of the steel sheet S is caused to slide on the part of the die 51 corresponding to the top sheet section 11.

[0013] In addition, "the state where the pad is caused to approach the steel sheet" means a state where the steel sheet and the pad do not come in contact with each other when the steel sheet slides on the part of the die corresponding to the top sheet section and the steel sheet and the pad come in contact with each other when the steel sheet is likely to undergo out-of-plane deformation (or buckling) on the corresponding part.

[0014] During forming of the vertical wall section 12 and the flange section 13, a part of a metal sheet S may be pressurized as an out-of-plane deformation suppressing area (area F) at a predetermined load pressure by the pad 52.

[0015] For example, when a pad load pressure is set to be high and thus "the portion that abuts on the top of the die 51" of the steel sheet S cannot sufficiently slide (perform in-plane movement) between the die 51 and the pad 52 during pressing, cracks are generated in the flange section 13.

[0016] In addition, when the load pressure by the pad 52 is set to be low and thus out-of-plane deformation of "the portion that abuts on the top of the die 51" of the steel sheet S cannot be restrained during pressing, wrinkles are

generated in the top sheet section 11.

[0017] When a metal sheet which is generally used for automobile components and the like and has a tensile strength of 200 MPa to 1,600 MPa is formed, when the metal sheet is pressured at a pressure of equal to or higher than 30 MPa, cracks are generated in the flange section 13. On the other hand, when the metal sheet is pressurized at a pressure of equal to or lower than 0.1 MPa, out-of-plane deformation of the top sheet section 11 cannot be sufficiently suppressed. Therefore, it is preferable that pressurizing by the pad 52 be performed at a pressure of equal to or higher than 0.1 MPa and equal to or lower than 30 MPa.

[0018] Moreover, in consideration of a pressing machine or a die unit for manufacturing general automobile components, since a load is low at a pressure of equal to or lower than 0.4 MPa, it is difficult to stably pressurize the pad 52 using a cushion gas. In addition, at a pressure of equal to or greater than 15 MPa, a high-pressure pressurizing apparatus is needed, and thus equipment costs are increased. Therefore, it is more preferable that pressurizing by the pad 52 be performed at a pressure of equal to or higher than 0.4 MPa and equal to or lower than 15 MPa.

[0019] The pressure mentioned herein is an average surface pressure obtained by dividing a pad pressurizing force by the area of the contact portion of the pad 52 and the steel sheet S, and may be slightly locally uneven.

[0020] In addition, during forming of the vertical wall section 12 and the flange section 13, a portion of the steel sheet S that approaches or comes in contact with an out-of-plane suppressing area of the pad as the out-of-plane deformation suppressing area (the area F) may be formed in a state where a clearance between the pad 52 and the die 51 is equal to or greater than the thickness of the steel sheet S and is maintained to be equal to or smaller than 1.1 times the thickness thereof.

[0021] For example, when the portion corresponding to the top sheet section 11 is formed in the state where the clearance between the pad 52 and the die 51 is equal to or greater than the thickness of the steel sheet S and is maintained to be equal to or smaller than 1.1 times the thickness thereof, the steel sheet S can sufficiently slide (perform in-plane movement) in the die unit 50 since an excessive surface pressure is not applied to the sheet S. Moreover, when a surplus thickness is provided in the top sheet section 11 as the forming proceeds and thus a force to cause the steel sheet S to undergo out-of-plane deformation is exerted, out-of-plane deformation of the steel sheet S is restrained by the pad 52, so that generation of cracks or wrinkles can be suppressed.

[0022] When the portion corresponding to the top sheet section 11 is formed by setting the clearance between the pad 52 and the die 51 to be smaller than the thickness of the steel sheet S, an excessive surface pressure is exerted between the steel sheet S and the die 51, and thus the steel sheet S cannot sufficiently slide (perform in-plane movement) in the die unit 50 and cracks are generated in the flange section 13.

[0023] On the other hand, when the portion corresponding to the top sheet section 11 is formed by setting the clearance between the pad 52 and the die 51 to be equal to or greater than 1.1 times the thickness of the steel sheet S, out-of-plane deformation of the steel sheet S cannot be sufficiently strained during pressing, so that the steel sheet S is significantly left at the top sheet section 11 as the forming proceeds. Therefore, in addition to the generation of significant wrinkles, buckling occurs in the top sheet section 11, so that the portion cannot be formed into a predetermined shape.

[0024] With regard to a portion of the metal sheet which is generally used for automobile components and the like and has a tensile strength of 200 MPa to 1,600 MPa, the portion being caused to approach or come in contact with the out-of-plane suppressing area of the pad 52 as the out-of-plane deformation suppressing area (the area F), when the portion is formed in the state where the clearance between the pad 52 and the die 51 is equal to or greater than the thickness of the sheet and is maintained to be equal to or smaller than 1.1 times the thickness of the sheet, small wrinkles are generated if the clearance between the pad 52 and the die 51 is equal to or greater than 1.03 times the thickness of the sheet. Therefore, it is more preferable that the clearance between the pad 52 and the die 51 be equal to or greater than the thickness of the sheet and equal to or smaller than 1.03 times the thickness of the sheet.

[0025] Specifically, in the press-forming method according to this embodiment, as shown in (a) and (b) of FIG. 8, when a steel sheet S is pressed to be formed into an L shape which has the vertical wall section 12, the flange section 13 connected to the vertical wall 12 with the one end portion, and the top sheet section 11 connected to an end portion of the vertical wall section 12 on the opposite side to the side connected to the flange section 13 and extends in the opposite direction to the flange section 13, and which is curved so that a part or the entirety of the vertical wall becomes the inside of the flange section 13, the steel sheet S having a shape in which an end portion of a part of the steel sheet S corresponding to the lower side of the L shape of the steel sheet S is inside the top sheet section 11 is disposed on a die 51, and the vertical wall section 12 and the flange section 13 are pressed by the bending die 53 while pressing the top sheet section 11 with the pad 52 or causing the top sheet section 11 to approach the pad 52. In FIG. 8, (a) shows the behavior of the steel sheet S along the arrow a-a of FIG. 6 during pressing, and FIG. 8B shows the behavior of the steel sheet S along the arrow b-b of FIG. 6 during pressing.

[0026] An L-shaped component 10 has the planar top sheet section 11 having an L shape, the vertical wall section 12, and the flange section 13 as shown in FIG. 6. The top sheet section 11 is connected to the vertical wall section 12 with the bent section 15 including the part 15a curved in the arc. The arc of the part 15a curved in the arc shape has a shape having a predetermined curvature, an elliptical shape, a shape having a plurality of curvatures, a shape having

a straight portion, or the like as viewed in the press direction. That is, in the L-shaped component 10, the top sheet section 11 exists on the outside of the arc of the part 15a curved in the arc shape, and the flange section 13 exists on the inside of the arc (on the center point side of the arc) of the part 15a curved in the arc shape. In addition, the top sheet section 11 does not need to be completely planar, and may have various additional shapes on the basis of the design of a press product.

[0027] According to the invention, as shown in FIG. 6, from both end portions of the part 15a curved in the arc shape in the L-shaped component 10, the end portion at a position distant from the end portion (the end portion of the lower side of the L shape) of the bent section 15 is referred to as an end portion A (first end portion), and the end portion at a position close to the end portion (the end portion of the lower side of the L shape) of the bent section 15 is referred to as an end portion B (second end portion). The bent section 15 has a part 15b extending substantially in a straight shape from the outside of the end portion A (the opposite side to the end portion B), and a part 15c extending substantially in a straight shape from the outside of the end portion B (the opposite side of the end portion A). Here, there may be a case where the end portion B of the part 15a curved in the arc shape is the same as an end portion of the bent section 15. In this case, the part 15c extending substantially in the straight shape from the outside of the end portion B (the opposite side of the end portion A) does not exist.

[0028] The steel sheet S has a shape from which the L-shaped component 10 is developed. That is, the steel sheet S has parts corresponding to the top sheet section 11, the vertical wall section 12, the flange section 13, and the like in the L-shaped component 10.

[0029] As the steel sheet S (the blank metal sheet), a pre-processed steel sheet (blank metal sheet) which is subjected to pre-processing such as press-forming, bend-forming, or perforating may also be used.

[0030] During forming of the vertical wall section 12 and the flange section 13, it is preferable that, in the end portion A (first end portion) which is one end portion of the part 15a curved in the arc shape of the bent section 15 when viewed in a direction perpendicular to a surface of the top sheet section 11 (press direction), from an area of the top sheet section 11 halved by a tangent line of a boundary line between the bent section 15 and the top sheet section 11, an area (a hatched portion of FIG 10) that abuts on the top sheet surface of the die 51 (a surface corresponding to the top sheet section of the steel sheet S) in an area of a side including the end portion B (second end portion) which is the other end portion of the part 15a curved in the arc shape of the bent section 15 be pressurized as an out-of-plane deformation suppressing area (area F). In this case, generation of wrinkles of the top sheet section 11 or the vertical wall section 12 can be suppressed. During pad pressurization, it is preferable that a pad having a shape to cover the entire surface of the part of the steel sheet S that abuts on the top sheet surface of the die 51 to a part of the steel sheet S that abuts on the top sheet surface of the die 51 while including the entire out-of-plane deformation suppressing area (the area F) be used. However, for example, when an additional shape exists in the out-of-plane deformation suppressing area (the area F) due to the design of a product, in order to avoid the additional shape, a pad having a shape to include, at least from a part of the out-of-plane deformation suppressing area (the area F) which abuts on a boundary line with the part of the bent section curved in the arc shape, an area within 5 mm from the boundary line, and to cover an area of 50% or greater of the out-of-plane deformation suppressing area (the area F) may be used. Moreover, a pad in which pressurizing surfaces are separated may be used.

[0031] In addition, it is preferable that, in the steel sheet S, in a part of the top sheet section 11, which abuts on a boundary line between the top sheet section 11 and the part 15a curved in the arc shape of the bent section 15, an area within at least 5 mm from the boundary line be pressurized by the pad 52. On the other hand, for example, when only an area within 4 mm from the boundary line is pressurized by the pad 52, wrinkles are more likely to be generated in the top sheet section 11. Here, the generation of wrinkles does not have a significant effect on product strength compared to the generation of cracks.

[0032] In FIG. 7, the die unit 50 used in the press-forming method according to this embodiment is shown. The die unit 50 includes the die 51, the pad 52, and the bending die 53.

[0033] A driving mechanism of the pad 52 used to pressurize the steel sheet S so that in-plane movement can be allowed in the part corresponding to the out-of-plane deformation suppressing area (the area F) may be a spring or a hydraulic pressure, and a cushion gas may be used as the pad 52.

[0034] In addition, with regard to part that approaches or comes in contact with the out-of-plane deformation suppressing area (the area F), a driving mechanism of the pad 52 used to form the vertical wall section 12 and the flange section 13 in a state where a clearance of the pad 52 and the die 51 is maintained to be equal to or greater than the thickness of the steel sheet S and to be equal to or smaller than 1.1 times the thickness thereof may be a motor cylinder, a hydraulic servo apparatus, or the like.

[0035] In the press-forming method according to this embodiment, the steel sheet S having a shape from which a formed body is developed, which is shown in FIG 9A, is installed on the die 51 as shown in FIG. 9B. In addition, in the state where the part corresponding to the top sheet section 11 of the L-shaped component 10 is pressurized against the die 51 by the pad 52, the bending die 53 is lowered in the press direction P, such that the vertical wall section 12 and the flange section 13 are formed as shown in FIG. 9C.

[0036] As described above, as the bending die 53 is lowered in the press direction, the steel sheet S is deformed along the shapes of the vertical wall section 12 and the flange section 13. Here, in the steel sheet S, the part corresponding to the vertical wall section 12 of the lower side portion of the L shape flows into the vertical wall section 12. That is, since the position in the steel sheet S corresponding to the top sheet section 11 of the lower side portion of the L shape is stretched, generation of wrinkles in the top sheet section 11, in which wrinkles are more likely to be generated due to an inflow of an excessive metal material during typical drawing, is suppressed. In addition, since the position in the steel sheet S corresponding to the flange section 13 of the lower side portion of the L shape is not excessively stretched, generation of cracks in the flange section 13, in which cracks are more likely to be generated due to a reduction in the thickness of the sheet during typical drawing, is suppressed. As the generation of wrinkles and cracks is suppressed as described above, a large trim area for blank holding does not need to be provided in the part of the steel sheet S corresponding to the lower side portion of the L shape of the L-shaped component, unlike a typical forming method.

[0037] The shape of the steel sheet S may be a shape in which an end portion of at least a part thereof is on the same plane as the top sheet section 11 (a shape in which the end portion is not wound during press-forming). That is, as shown in FIG. 10, it is preferable that the end portion of the part corresponding to the out-of-plane deformation suppressing area (the area F) in the steel sheet S be on the same plane as the top sheet section 11.

[0038] If the height H of the vertical wall section 12 to be formed is smaller than 0.2 times the length of the part 15a curved in the arc shape of the bent section 15 or smaller than 20 mm, wrinkles are more likely to be generated in the vertical wall section 12. Therefore, it is preferable that the height H of the vertical wall section 12 be equal to or greater than 0.2 times the length of the part 15a curved in the arc shape of the bent section 15 or equal to or greater than 20 mm.

[0039] In addition, since a reduction in the thickness of the sheet due to forming is suppressed, in addition to a steel sheet having high ductility and relatively low strength (for example, a steel sheet having a breaking strength of about 1,600 MPa), even a steel sheet having low ductility and relatively high strength (for example, a steel sheet having a breaking strength of about 400 MPa) can be properly press-formed. Therefore, as the steel sheet S, a high-strength steel sheet having a breaking strength of equal to or higher than 400 MPa and equal to or lower than 1,600 MPa may be used.

[0040] Moreover, in the press-forming method according to this embodiment, the width h_i of the flange section 13 on the upper side from the center of the curve of the vertical wall may be equal to or greater than 25 mm and equal to or smaller than 100 mm. More specifically, it is preferable that the press-forming be performed so that in the flange section 13, in a portion of the vertical wall section 12 connected to the part 15a curved in the arc shape of the bent section 15, the widths h_i of a flange portion 13a of the end portion A side from a center line C in a longitudinal direction (peripheral direction) of the flange section 13 of the portion connected to the opposite side to the top sheet section 11 and a flange portion 13b (that is, an area O) in front of the flange portion of the end portion A side by 50 mm are equal to or greater than 25 mm and equal to or smaller than 100 mm.

[0041] The width h_i is defined as a shortest distance from an arbitrary position in the flange end portions of the flange portions 13a and 13b, to a position on the boundary line between the vertical wall section and the flange section.

[0042] When points of which the widths h_i are smaller than 25 mm exist in the flange portions 13a and 13b, a reduction in the thickness of the flange section is increased, and therefore cracks are more likely to be generated. This is because a force to draw the front end portion of the lower side portion of the L shape into the vertical wall section 12 during forming is concentrated on the vicinity of the flange section.

[0043] When points of which the widths h_i are greater than 100 mm exist in the flange portions 13a and 13b, an amount of the flange section 13 compressed is increased, and therefore wrinkles are more likely to be generated.

[0044] Therefore, by causing the width h_i to be equal to and greater than 25 mm and equal to and smaller than 100 mm, generation of wrinkles and cracks in the flange section 13 can be suppressed.

[0045] Accordingly, when a component having a shape in which the width h_i of the flange section on the inside of the L shape is smaller than 25 mm is manufactured, it is preferable that after press-forming the L shape having the flange section of which the width is equal to or greater than 25 mm, unnecessary portions be trimmed.

[0046] Furthermore, a radius of curvature of a maximum curvature portion of the curve of the vertical wall section 12, that is, a radius (RMAX) of curvature of a maximum curvature portion of the boundary line between the part 15a curved in the arc shape of the bent section 15 and the top sheet section 11, be equal to or greater than 5 mm and equal to or smaller than 300 mm.

[0047] When the radius of curvature of the maximum curvature portion is smaller than 5 mm, the periphery of the maximum curvature portion is locally pulled outward, and therefore cracks are more likely to be generated.

[0048] When the radius of curvature of the maximum curvature portion is greater than 300 mm, the length of the front end of the lower portion of the L shape is lengthened and thus the distance drawn into the inside (the vertical wall section 12) of the L shape is increased during press-forming, so that a sliding distance between the die unit 50 and the steel sheet S is increased. Therefore, wear of the die unit is accelerated, resulting in a reduction in the life-span of the die. It is more preferable that the radius of curvature of the maximum curvature portion be smaller than 100 mm.

[0049] In the above-described embodiment, the forming method of a member having a single L shape is exemplified.

However, the invention can also be applied to forming of a component having a shape of two L characters (a T-shaped component and the like), or a component having a shape of two or more L characters (a Y-shaped component and the like). That is, when a shape having a plurality of L characters is to be press-formed, forming may be performed by the forming method of the L shape described above to form a shape of a single L character, a plurality of L characters, or any L character. In addition, the top sheet section 11 may have an L shape, a T shape, or a Y shape. Moreover, the top sheet section 11 may have a T shape or Y shape which is left-right asymmetric.

[0050] In addition, a vertical positional relationship between the die 51 and the bending die 53 is not limited to that of the invention.

[0051] Moreover, the blank metal sheet according to the invention is not limited only to the steel sheet S. For example, blank metal sheets suitable for press-forming, such as, an aluminum sheet or a Cu-Al alloy sheet may also be used.

Examples

[0052] In Examples 1 to 52, formed bodies each of which has a top sheet section, a vertical wall section, and a flange section were formed using a die unit having a pad mechanism. Perspective views ((a) in the figures) of the formed bodies formed in Examples 1 to 52, and plan views of an area O (an area of (arc length)/2 mm+50 mm), an area F (an out-of-plane deformation suppressing area), and a pressurized position which was actually pressurized and is shown as hatched sections ((b), (c), and (d) in the figures) are shown in FIGS. 11 to 32. The unit of dimensions indicated in FIGS. 11 to 32 is mm. In addition, the end portion A (the first end portion) and the end portion B (the second end portion) of the formed body which is press-formed in each example are shown as A and B in the figures, respectively.

[0053] In Tables 1A and 1B, figures corresponding to the respective examples are indicated, and with regard to the material of the blank metal sheet used in each example, "blank metal sheet type", "sheet thickness (mm)", and "breaking strength (MPa)" are shown.

[0054] In Tables 2A and 2B, with regard to the shape of the formed body formed in each example, "top sheet shape", "arc length (mm)", "arc length \times 0.2", "radius of curvature of maximum curvature portion of arc", "height H of vertical wall section", "A end flange width (mm)", "shape of arc", "winding of end portion", "shape of front of A end", and "additional shape of top sheet section" are shown.

[0055] In Tables 3A and 3B, with regard to the forming condition, "pressurized position", "pressurized range from boundary line (mm)", "pre-processing", "forming load (ton)", "pad load pressure (MPa)", and "ratio of clearance between pad and die to sheet thickness (clearance between pad and die/sheet thickness)" are shown.

[0056] In Tables 4A and 4B, results of "wrinkle evaluation of flange section", "crack evaluation of flange section", "wrinkle evaluation of top sheet section", "crack evaluation of top sheet section", and "wrinkle evaluation of vertical wall section" are shown.

[0057] In the wrinkle evaluations of the flange section, the top sheet section, and the vertical wall section, a case where no wrinkle was observed by visual inspection was evaluated as A, a case where small wrinkles were observed was evaluated as B, a case where wrinkles were observed was evaluated as C, a case where significant wrinkles were observed was evaluated as D, and a case where buckling deformation was observed was evaluated as X. In addition, in the crack evaluations of the flange section and the top sheet section, a case where no crack was generated was evaluated as O, a case where necking (a portion where the sheet thickness is locally reduced by 30% or higher) was generated was evaluated as Δ , and a case where cracks were generated was evaluated as X.

[Table 1A]

[Table 1B]

[Table 2A]

[Table 2B]

[Table 3A]

[Table 3B]

[Table 4A]

[Table 4B]

[0058] In Examples 1 and 41, a formed body shown in FIG. 11 was press-formed by employing an appropriate forming condition. No crack and wrinkle was generated in the formed body.

[0059] In Examples 2 and 42, the formed body shown in FIG. 11 was press-formed by setting the pad load pressure to be lower than that of Example 1. In the formed body, wrinkles were generated in the top sheet section and small wrinkles were generated in the vertical wall section. However, since no crack was generated, there was no problem with product strength.

[0060] In Examples 3, 43, and 44, the formed bodies shown in FIG. 11 were press-formed by setting the pad load pressure to be higher than that of Example 1. Accordingly, the blank metal sheet could not sufficiently slide (perform in-

plane movement) in the pressurized position, and cracks were generated in the flange section.

[0061] In Examples 45 to 52, the formed bodies shown in FIG. 11 were press-formed by setting the ratio of the clearance between the pad and the die to the sheet thickness (the clearance between the pad and the die/the sheet thickness) to 1.00 to 2.00. As a result, in Example 49 in which the ratio of the clearance between the pad and the die to the sheet thickness is set to 1.80 and in Example 52 in which the ratio of the clearance between the pad and the die to the sheet thickness is set to 2.00, buckling deformation had occurred in the top sheet section, so that a desired product shape could not be obtained.

[0062] In Example 4, a formed body shown in FIG. 12 was press-formed by pressurizing an area other than the out-of-plane deformation suppressing area (the area F) with the pad. In the formed body, significant wrinkles were generated in the top sheet section, and small wrinkles were generated in the vertical wall section. However, since no crack was generated, there was no problem with product strength.

[0063] In Example 5, a formed body shown in FIG. 13 was press-formed by pressurizing an area including the entire out-of-plane suppressing area (the area F) with the pad. In the formed body, no wrinkle and crack was generated.

[0064] In Example 6, a formed body shown in FIG. 14 was press-formed. In this example, as shown in FIG. 14, since the end portion of the part corresponding to the out-of-plane formation suppressing (the area F) does not exist on the same plane as the top sheet section, that is, since the end portion is wound, cracks were generated in the flange section.

[0065] In Examples 7 to 10, formed bodies shown in FIGS. 15, 16, 17, and 18 were press-formed. In these examples, even when the arc is elliptical (Example 7), the arc has a plurality of curvatures (R) (Example 8), the arc has a straight portion (Example 9), or the front end of the arc is the end portion of the bent section (Example 10), it could be seen that the effects of the invention were sufficiently obtained.

[0066] In Examples 11 to 13, formed bodies shown in FIGS. 19, 20, and 21 were press-formed. In these examples, according to the product designs, even when the shape of the front of the A end is non-straight (Examples 11 and 13), or the top sheet section has an additional shape (Example 13), it could be seen that the effects of the invention were sufficiently obtained. Particularly, in Example 13, even when the entire out-of-plane deformation suppressing area (the area F) could not be pressurized by the pad since a small additional shape existed in a part of the out-of-plane deformation suppressing area (the area F), it could be seen that the effects of the invention were obtained.

[0067] In Examples 14 to 17, formed bodies shown in FIG. 22 were press-formed by setting the height H of the vertical wall section to 10 mm (Example 14), 15 mm (Example 15), 20 mm (Example 16), and 30 mm (Example 17). In these examples, it could be seen that wrinkles of the vertical wall section could be suppressed by setting the height H of the vertical wall section to 20 mm or greater. In Examples 14 and 15 in which the heights of the vertical wall sections were smaller than 20 mm, wrinkles were generated in the vertical wall sections. However, since no crack was generated, there was no problem with product strength.

[0068] In Examples 18 to 20, formed bodies shown in FIG. 23 were press-formed by setting the height H of the vertical wall section to 5 mm (Example 18), 14 mm (Example 19), and 18 mm (Example 20) after setting the arc length to 66 mm (arc length \times 0.2=13.2). In this example, it could be seen that by setting the height H of the vertical wall section to be equal to or greater than 0.2 times the arc length, wrinkles of the vertical wall section could be suppressed even though the height of the vertical wall section was smaller than 20 mm. In Example 18 in which the height H of the vertical wall section is smaller than 0.2 times the arc length, wrinkles were generated in the vertical wall section. However, since no crack was generated, there was no problem with product strength.

[0069] In Example 21 to 23, formed bodies shown in FIGS. 24, 25, and 26 were press-formed by pressurizing, in a part which abuts on a boundary line between the top sheet section and the part curved in the arc shape of the bent section, an area within 3 mm (Example 21), 5 mm (Example 22), or 8 mm (Example 23) from the boundary line, with the pad. In these examples, it could be seen that by pressurizing the area within at least 5 mm from the boundary line with the pad, generation of wrinkles in the top sheet section could be suppressed.

[0070] In Examples 24 to 28, formed bodies shown in FIG. 27 were press-formed by setting the flange width at the A end to 20 mm (Example 24), 25 mm (Example 25), 80 mm (Example 26), 100 mm (Example 27), and 120 mm (Example 28). In these examples, it could be seen that by setting the flange width to be in the range of 25 mm to 100 mm, generation of wrinkles and cracks could be suppressed. In Example 24, necking had occurred in the flange section by setting the flange width to 20 mm, and in Example 28, significant wrinkles were generated in the flange section and necking had occurred in the top sheet section by setting the flange width to 120 mm. However, since no crack was exhibited, there was no significant problem with strength characteristics.

[0071] In Examples 29 to 32, formed bodies shown in FIG. 28 were press-formed by setting the radius of curvature of the maximum curvature portion of the arc to 3 mm (Example 29), 5 mm (Example 30), 10 mm (Example 31), and 20 mm (Example 31) when the arc has a straight portion (R+Straight+R). In these examples, it could be seen that by setting the radius of curvature of the maximum curvature portion of the arc to be equal to or greater than 5 mm, wrinkles of the vertical wall section could be suppressed.

[0072] In Examples 33 to 36, formed bodies were press-formed by setting the maximum radius of curvature of the arc to 200 mm (Example 33), 250 mm (Example 34), 300 mm (Example 35), and 350 mm (Example 36). In these

examples, it could be seen that by setting the radius of curvature of the maximum curvature portion of the arc to be 300 mm or smaller, generation of wrinkles of the vertical wall section could be suppressed.

[0073] In Examples 37 and 38, a T-shaped formed body shown in FIG. 30 was press-formed. As the blank metal sheet, a steel sheet (Example 37) obtained by pre-processing the shape shown in FIG. 33 and a pre-processed aluminum sheet (Example 38) were used. In these examples, it could be seen that the press-forming method according to the invention could be employed for forming the T-shaped formed body, and the blank metal sheet according to the invention was not limited to the steel sheet.

[0074] In Examples 39 and 40, a T-shaped formed body shown in FIG 31, which is left-right asymmetric (Example 39), and a Y-shaped formed body shown in FIG. 32 (Example 40) were press-formed. In these examples, it could be seen that the press-forming method according to the invention could be adequately applied to forming of a formed body having a shape of one or more L characters.

[0075] According to the invention, even when the blank metal sheet having low ductility and high strength is used, the component having the L shape can be press-formed while suppressing generation of wrinkles and cracks.

Table 1A

	Corresponding figure	Material		
		Metal sheet type	Sheet thickness	Breaking strength
			(mm)	MPa
Example 1	FIG. 11	Steel sheet	1,2	980
Example 2	FIG. 11	Steel sheet	1,2	980
Example 3	FIG. 11	Steel sheet	1,2	980
Example 41	FIG. 11	Steel sheet	1,6	590
Example 42	FIG. 11	Steel sheet	1,6	590
Example 43	FIG. 11	Steel sheet	1,6	590
Example 44	FIG. 11	Steel sheet	1,8	270
Example 45	FIG. 11	Steel sheet	1,2	980
Example 46	FIG. 11	Steel sheet	1,2	980
Example 47	FIG. 11	Steel sheet	1,2	980
Example 48	FIG. 11	Steel sheet	1,2	980
Example 49	FIG. 11	Steel sheet	1,2	980
Example 50	FIG. 11	Steel sheet	1,6	590
Example 51	FIG. 11	Steel sheet	1,6	590
Example 52	FIG. 11	Steel sheet	1,6	590
Example 4	FIG. 12	Steel sheet	1,2	980
Example 5	FIG. 13	Steel sheet	1,2	980
Example 6	FIG. 14	Steel sheet	1,2	980
Example 7	FIG. 15	Steel sheet	2,3	440
Example 8	FIG. 16	Steel sheet	0,8	590
Example 9	FIG. 17	Steel sheet	1,6	1180
Example 10	FIG. 18	Steel sheet	1,2	1380
Example 11	FIG. 19	Steel sheet	1,2	980
Example 12	FIG. 20	Steel sheet	1,2	980
Example 13	FIG. 21	Steel sheet	1,2	980
Example 14	FIG. 22	Steel sheet	1,2	980

Table 1B

	Corresponding figure	Material		
		Metal sheet type	Sheet thickness	Breaking strength
			(mm)	MPa
Example 15	FIG. 22	Steel sheet	1,2	980
Example 16	FIG. 22	Steel sheet	1,2	980
Example 17	FIG. 22	Steel sheet	1,2	980
Example 18	FIG. 23	Steel sheet	0,8	980
Example 19	FIG. 23	Steel sheet	0,8	980
Example 20	FIG. 23	Steel sheet	0,8	980
Example 21	FIG. 24	Steel sheet	1,2	980
Example 22	FIG. 25	Steel sheet	1,2	980
Example 23	FIG. 26	Steel sheet	1,2	980
Example 24	FIG. 27	Steel sheet	1,2	980
Example 25	FIG. 27	Steel sheet	1,2	980
Example 26	FIG. 27	Steel sheet	1,2	980
Example 27	FIG. 27	Steel sheet	1,2	980
Example 28	FIG. 27	Steel sheet	1,2	980
Example 29	FIG. 28	Steel sheet	1,2	270
Example 30	FIG. 28	Steel sheet	1,2	270
Example 31	FIG. 28	Steel sheet	1,2	270
Example 32	FIG. 28	Steel sheet	1,2	270
Example 33	FIG. 29	Steel sheet	1,2	270
Example 34	FIG. 29	Steel sheet	1,2	270
Example 35	FIG. 29	Steel sheet	1,2	270
Example 36	FIG. 29	Steel sheet	1,2	270
Example 37	FIGS. 30,33	Steel sheet	1,8	980
Example 38	FIGS. 30,33	Aluminum	1,8	296
Example 39	FIG. 31	Steel sheet	1,8	980
Example 40	FIG. 32	Steel sheet	1,8	980

Table 2A

	Shape									
	Top sheet shape	Arc length (mm)	Arc length ×0.2	Radius of curvature of maximum curvature portion of arc (mm)	Height H of vertical wall section (mm)	End flange width (mm)	Shape of arc	Winding of end portion	Shape of front of A end	Additional shape of top sheet section
Example 1	L	217	43,4	138	60	40	R	No	Straight	No
Example 2	L	217	43,4	138	60	40	R	No	Straight	No
Example 3	L	217	43,4	138	60	40	R	No	Straight	No
Example 41	L	217	43,4	138	60	40	R	No	Straight	No
Example 42	L	217	43,4	138	60	40	R	No	Straight	No
Example 43	L	217	43,4	138	60	40	R	No	Straight	No
Example 44	L	217	43,4	138	60	40	R	No	Straight	No
Example 45	L	217	43,4	138	60	40	R	No	Straight	No
Example 46	L	217	43,4	138	60	40	R	No	Straight	No
Example 47	L	217	43,4	138	60	40	R	No	Straight	No
Example 48	L	217	43,4	138	60	40	R	No	Straight	No
Example 49	L	217	43,4	138	60	40	R	No	Straight	No
Example 50	L	217	43,4	138	60	40	R	No	Straight	No
Example 51	L	217	43,4	138	60	40	R	No	Straight	No
Example 52	L	217	43,4	138	60	40	R	No	Straight	No
Example 4	L	217	43,4	138	60	40	R	No	Straight	No
Example 5	L	217	43,4	138	60	40	R	No	Straight	No
Example 6	L	217	43,4	138	60	40	R	Yes	Straight	No
Example 7	L	211	42,2	80	60	40	Elliptical	No	Straight	No

5
10
15
20
25
30
35
40
45
50
55

(continued)

Shape										
Top sheet shape	Arc length		Radius of curvature of maximum curvature portion of arc (mm)	Height H of vertical wall section (mm)	End flange width		Shape of arc	Winding of end portion	Shape of front of A end	Additional shape of top sheet section
	(mm)	$\times 0.2$			(mm)	(mm)				
Example 8	L	220	44	89	60	40	Complex R	No	Straight	No
Example 9	L	157	31,4	68	60	40	R+Straight+R	No	Straight	No
Example 10	L	217	43,4	138	60	40	R	No	Straight	No
Example 11	L	217	43,4	138	60	40	R	No	Non-straight ₁	No
Example 12	L	294	58,8	138	60	40	R	No	Non-straight ₂	No
Example 13	L	217	43,4	138	60	40	R	No	Non-straight ₃	Yes
Example 14	L	217	43,4	138	10	40	R	No	Straight	No

Table 2B

	Shape									
	Top sheet shape	Arc length (mm)	Arc length ×0.2	Radius of curvature of maximum curvature portion of arc (mm)	Height H of vertical wall section (mm)	End flange width (mm)	Shape of arc	Winding of end portion	Shape of front of A end	Additional shape of top sheet section
Example 15	L	217	43,4	138	15	40	R	No	Straight	No
Example 16	L	217	43,4	138	20	40	R	No	Straight	No
Example 17	L	217	43,4	138	30	40	R	No	Straight	No
Example 18	L	66	13,2	42	5	25	R	No	Straight	No
Example 19	L	66	13,2	42	14	25	R	No	Straight	No
Example 20	L	66	13,2	42	18	25	R	No	Straight	No
Example 21	L	66	13,2	42	14	25	R	No	Straight	No
Example 22	L	66	13,2	42	14	25	R	No	Straight	No
Example 23	L	66	13,2	42	14	25	R	No	Straight	No
Example 24	L	217	43,4	138	60	20	R	No	Straight	No
Example 25	L	217	43,4	138	60	25	R	No	Straight	No
Example 26	L	217	43,4	138	60	80	R	No	Straight	No
Example 27	L	217	43,4	138	60	100	R	No	Straight	No
Example 28	L	217	43,4	138	60	120	R	No	Straight	No
Example 29	L	108	21,6	3	60	40	R+Straight+R	No	Straight	No
Example 30	L	110	22	5	60	40	R+Straight+R	No	Straight	No
Example 31	L	113	22,6	10	60	40	R+Straight+R	No	Straight	No
Example 32	L	121	24,2	20	60	40	R+Straight+R	No	Straight	No
Example 33	L	268	53,6	200	60	40	R	No	Straight	No

5
10
15
20
25
30
35
40
45
50
55

(continued)

Shape										
Additional shape of top sheet section	Shape of front of A end	Winding of end portion	Shape of arc	End flange width		Height H of vertical wall section	Radius of curvature of maximum curvature portion of arc	Arc length		Top sheet shape
				(mm)	(mm)			$\times 0.2$	(mm)	
No	Straight	No	R	40	60	250	59	295	L	Example 34
No	Straight	No	R	40	60	300	64,6	323	L	Example 35
No	Straight	No	R	40	60	350	68,6	343	L	Example 36
No	Straight	No	R	40	60	138	43,4	217	T1	Example 37
No	Straight	No	R	40	60	138	43,4	217	T1	Example 38
No	Straight	No	R	40	60	138	36,2	181	T2	Example 39
No	Straight	No	R	40	60	138	36,2	181	Y	Example 40

EP 2 524 740 A1

Table 3A

	Forming condition							
	Pressurized position		Pressurized range from boundary line	Pre-processing	Forming load (ton)	Pad load pressure (MPa)	Ratio of clearance between pad and die to sheet thickness	
	Area F of top sheet section	Other than area F of top sheet section						
5	Example 1	Entire surface	Entire surface	8 mm or greater	No	200	3,8	-
10	Example 2	Entire surface	Entire surface	8 mm or greater	No	200	0,1	-
15	Example 3	Entire surface	Entire surface	8 mm or greater	No	200	35,0	-
20	Example 41	Entire surface	Entire surface	8 mm or greater	No	200	10,0	-
25	Example 42	Entire surface	Entire surface	8 mm or greater	No	200	0,1	-
30	Example 43	Entire surface	Entire surface	8 mm or greater	No	150	32,0	-
35	Example 44	Entire surface	Entire surface	8 mm or greater	No	150	32,0	-
40	Example 45	Entire surface	Entire surface	8 mm or greater	No	200	-	1,00
45	Example 46	Entire surface	Entire surface	8 mm or greater	No	200	-	1,02
50	Example 47	Entire surface	Entire surface	8 mm or greater	No	200	-	1,03
55	Example 48	Entire surface	Entire surface	8 mm or greater	No	200	-	1,09
	Example 49	Entire surface	Entire surface	8 mm or greater	No	200	-	1,80
	Example 50	Entire surface	Entire surface	8 mm or greater	No	200	-	1,00
	Example 51	Entire surface	Entire surface	8 mm or greater	No	200	-	1,07
	Example 52	Entire surface	Entire surface	8 mm or greater	No	200	-	2,00
	Example 4	-	Entire surface	8 mm or greater	No	200	3,9	-
	Example 5	Entire surface	Partial	8 mm or greater	No	200	6,2	-
	Example 6	Entire surface	Entire surface	8 mm or greater	No	200	3,8	-
	Example 7	Entire surface	Entire surface	8 mm or greater	No	300	3,8	-

EP 2 524 740 A1

(continued)

5	Forming condition							
	Pressurized position		Pressurized range from boundary line	Pre-processing	Forming load (ton)	Pad load pressure MPa	Ratio of clearance between pad and die to sheet thickness	
	Area F of top sheet section	Other than area F of top sheet section						
10	Example 8	Entire surface	Entire surface	8 mm or greater	No	200	3,8	-
15	Example 9	Entire surface	Entire surface	8 mm or greater	No	400	5,1	-
20	Example 10	Entire surface	Entire surface	8 mm or greater	No	450	4,7	-
25	Example 11	Entire surface	Entire surface	8 mm or greater	No	200	3,8	-
	Example 12	Entire surface	Entire surface	8 mm or greater	No	200	3,8	-
	Example 13	Partial	Partial	8 mm or greater	No	200	6,0	-
	Example 14	Entire surface	Entire surface	8 mm or greater	No	150	3,0	-

30 Table 3B

35	Forming condition							
	Pressurized position		Pressurized range from boundary line	Pre-processing	Forming load (ton)	Pad load pressure MPa	Ratio of clearance between pad and die to sheet thickness	
	Area F of top sheet section	Other than area F of top sheet section						
40	Example 15	Entire surface	Entire surface	8 mm or greater	No	150	3,0	-
45	Example 16	Entire surface	Entire surface	8 mm or greater	No	150	3,0	-
50	Example 17	Entire surface	Entire surface	8 mm or greater	No	150	3,0	-
	Example 18	Entire surface	Entire surface	8 mm or greater	No	150	3,0	-
	Example 19	Entire surface	Entire surface	8 mm or greater	No	150	3,0	-
	Example 20	Entire surface	Entire surface	8 mm or greater	No	150	3,0	-
55	Example 21	Partial	Partial	Within 3 mm	No	150	6,2	-
	Example 22	Partial	Partial	Within 5 mm	No	150	6,2	-

EP 2 524 740 A1

(continued)

5	Forming condition							
	Pressurized position		Pressurized range from boundary line	Pre-processing	Forming load	Pad load pressure	Ratio of clearance between pad and die to sheet thickness	
	Area F of top sheet section	Other than area F of top sheet section			(ton)	MPa		
10	Example 23	Partial	Partial	Within 8 mm	No	150	6,2	-
15	Example 24	Entire surface	Entire surface	8 mm or greater	No	200	3,8	-
	Example 25	Entire surface	Entire surface	8 mm or greater	No	200	3,8	-
20	Example 26	Entire surface	Entire surface	8 mm or greater	No	200	3,8	-
	Example 27	Entire surface	Entire surface	8 mm or greater	No	200	3,8	-
	Example 28	Entire surface	Entire surface	8 mm or greater	No	200	3,8	-
25	Example 29	Entire surface	Entire surface	8 mm or greater	No	70	3,8	-
	Example 30	Entire surface	Entire surface	8 mm or greater	No	70	3,8	-
30	Example 31	Entire surface	Entire surface	8 mm or greater	No	70	3,8	-
	Example 32	Entire surface	Entire surface	8 mm or greater	No	70	3,8	-
35	Example 33	Entire surface	Entire surface	8 mm or greater	No	200	3,8	-
	Example 34	Entire surface	Entire surface	8 mm or greater	No	200	3,8	-
40	Example 35	Entire surface	Entire surface	8 mm or greater	No	200	3,8	-
	Example 36	Entire surface	Entire surface	8 mm or greater	No	200	3,8	-
45	Example 37	Entire surface	Entire surface	8 mm or greater	Yes	300	5,2	-
	Example 38	Entire surface	Entire surface	8 mm or greater	Yes	150	1,4	-
50	Example 39	Entire surface	Entire surface	8 mm or greater	Yes	300	5,2	-
55	Example 40	Entire surface	Entire surface	8 mm or greater	Yes	300	5,2	-

EP 2 524 740 A1

Table 4A

	Evaluation					
	Wrinkle evaluation of flange section	Crack evaluation of flange section	Wrinkle evaluation of top sheet section	Crack evaluation of top sheet section	Wrinkle evaluation of vertical wall section	
5	Example 1	A	○	A	○	A
	Example 2	A	○	D	○	B
10	Example 3	A	×	A	○	A
	Example 41	A	○	A	○	A
	Example 42	A	○	D	○	B
15	Example 43	A	×	A	○	A
	Example 44	A	×	A	○	A
	Example 45	A	○	A	○	A
	Example 46	A	○	A	○	A
20	Example 47	A	○	A	○	A
	Example 48	A	○	C	○	B
	Example 49	A	○	×	○	C
25	Example 50	A	○	A	○	A
	Example 51	A	○	C	○	A
	Example 52	A	○	×	○	C
	Example 4	A	○	D	○	B
30	Example 5	A	○	A	○	A
	Example 6	A	×	B	○	B
	Example 7	A	○	A	○	A
35	Example 8	A	○	A	○	A
	Example 9	A	○	A	○	A
	Example 10	A	○	A	○	A
	Example 11	A	○	A	○	A
40	Example 12	A	○	A	○	A
	Example 13	A	○	A	○	A
	Example 14	A	○	A	○	C

45

Table 4B

	Evaluation					
	Wrinkle evaluation of flange section	Crack evaluation of flange section	Wrinkle evaluation of top sheet section	Crack evaluation of top sheet section	Wrinkle evaluation of vertical wall section	
50	Example 15	A	○	A	○	C
	Example 16	A	○	A	○	A
55	Example 17	A	○	A	○	A
	Example 18	A	○	A	○	C

(continued)

	Evaluation					
	Wrinkle evaluation of flange section	Crack evaluation of flange section	Wrinkle evaluation of top sheet section	Crack evaluation of top sheet section	Wrinkle evaluation of vertical wall section	
5	Example 19	A	○	A	○	A
	Example 20	A	○	A	○	A
10	Example 21	A	○	D	○	A
	Example 22	A	○	B	○	A
	Example 23	A	○	A	○	A
15	Example 24	A	△	A	○	A
	Example 25	A	○	A	○	A
	Example 26	A	○	A	○	A
	Example 27	B	○	A	○	A
20	Example 28	D	○	A	△	A
	Example 29	A	○	A	○	D
	Example 30	A	○	A	○	B
25	Example 31	A	○	A	○	A
	Example 32	A	○	A	○	A
	Example 33	A	○	A	○	A
	Example 34	A	○	A	○	B
30	Example 35	A	○	A	○	B
	Example 36	A	○	A	○	D
	Example 37	A	○	A	○	A
35	Example 38	A	○	A	○	A
	Example 39	A	○	A	○	A
	Example 40	A	○	A	○	A

40

Claims

1. A forming method of a press component having an L shape for forming a component having a top sheet section and a vertical wall section, which is connected to the top sheet section with a bent section having a part curved in an arc shape and has a flange section on the opposite side to the bent section, the top sheet section being on the outside of the arc of the vertical wall section, from a blank metal sheet, comprising:

disposing the blank metal sheet between a die or a pad and a bending die; and
 in a state where the pad is caused to approach or come in contact with the blank metal sheet, forming the vertical wall section and the flange section while at least a part of the blank metal sheet is caused to slide on a part of the die corresponding to the top sheet section.

2. The method according to claim 1, wherein, in the forming of the vertical wall section and the flange section, a part of the metal sheet is pressurized as an out-of-plane deformation suppressing area by the pad.

3. The method according to claim 1, wherein, in the forming of the vertical wall section and the flange section, a portion of the metal sheet that approaches or comes in contact with an out-of-plane suppressing area of the pad as the out-of-plane deformation suppressing area is formed in a state where a clearance between the pad and the die is

equal to or greater than the thickness of the blank metal sheet and is maintained to be equal to or smaller than 1.1 times the thickness of the blank metal sheet.

- 5
4. The method according to claim 2 or 3, wherein the out-of-plane deformation suppressing area is in a first end portion which is one end portion of the part curved in the arc shape of the bent section when viewed in a direction perpendicular to a surface of the top sheet section, from an area of the top sheet section halved by a tangent line of a boundary line between the bent section and the top sheet section, an area of the blank metal sheet which abuts on the part of the die corresponding to the top sheet section on a side including a second end portion which is the other end portion of the part curved in the arc shape of the bent section.
- 10
5. The method according to any one of claims 2 to 4, wherein, in the end portion of the blank metal sheet, from the part of the blank metal sheet corresponding to the out-of-plane deformation suppressing area, a portion which becomes the end portion of the part further on the top sheet side than the bent section is on the same plane as the top sheet section.
- 15
6. The method according to any one of claims 1 to 5, wherein the top sheet section has an L shape, a T shape, or a Y shape.
- 20
7. The method according to any one of claims 1 to 6, wherein a height of the vertical wall section is equal to or greater than 0.2 times a length of the part curved in the arc shape of the bent section, or equal to or greater than 20 mm.
- 25
8. The method according to any one of claims 1 to 7, wherein, in a part of the top sheet section in the blank metal sheet, which abuts on a boundary line between the top sheet section and the part curved in the arc shape of the bent section, an area within at least 5 mm from the boundary line is caused to approach or come in contact with the pad.
- 30
9. The method according to any one of claims 4 to 8, wherein, in the flange section, in a portion of the vertical wall section connected to the part curved in the arc shape of the bent section, widths of a flange portion of the first end portion side from a center portion in a longitudinal direction of the flange of the portion connected to the opposite side to the top sheet section and a flange portion in front of the flange portion of the first end portion side by 50 mm or greater are equal to or greater than 25 mm and equal to or smaller than 100 mm.
- 35
10. The method according to any one of claims 1 to 9, wherein a radius of curvature of a maximum curvature portion of the boundary line between the part curved in the arc shape of the bent section and the top sheet section is equal to or greater than 5 mm and equal to or smaller than 300 mm.
- 40
11. The method according to any one of claims 1 to 10, wherein a pre-processed blank metal sheet is press-formed as the blank metal sheet.
- 45
12. The method according to any one of claims 1 to 11, wherein a blank metal sheet having a breaking strength of equal to or higher than 400 MPa and equal to or lower than 1,600 MPa is used as the blank metal sheet.
- 50
13. A forming method of a press component having an L shape, comprising:
- performing forming by the method according to any one of claims 1 to 12 to form a shape of a single L character, a shape of a plurality of L characters, or a shape of any L character, when a shape having a plurality of L characters is press-formed.
- 55
14. A forming method of a press component having an L shape, for forming an L shape which has a vertical wall section, a flange section connected to one end portion of the vertical wall section, and a top sheet section that is connected to an end portion of the vertical wall section on the opposite side to a side connected to the flange section and extends in the opposite direction to the flange section and in which a part or the entirety of the vertical wall section is curved so that the flange section is on the inside, by pressing a blank metal sheet, comprising:
- performing forming by disposing a blank metal sheet having a shape in which an end portion of a part of the blank metal sheet corresponding to a lower side of the L shape is inside the top sheet section, on a die, and pressing the vertical wall section and the flange section with a bending die while pressing the top sheet section with a pad.

15. The method according to claim 14, wherein a width of the flange section on the upper side from the center of the curve of the vertical wall section is equal to or greater than 25 mm and equal to or smaller than 100 mm.

5 16. A forming method of a press component having an L shape, for forming an L shape which has a vertical wall section, a flange section connected to one end portion of the vertical wall section, and a top sheet section that is connected to an end portion of the vertical wall section on the opposite side to a side connected to the flange section and extends in the opposite direction to the flange section and in which a part or the entirety of the vertical wall section is curved so that the flange section is on the inside, by pressing a blank metal sheet, comprising:

10 disposing the blank metal sheet having a shape in which an end portion of a part of the blank metal sheet corresponding to the lower side of the L shape is inside the top sheet section, a margin thickness is provided in the flange section on the upper side from the center of the curve of the vertical wall section, and the sum of the thickness of the flange section and the margin thickness is equal to or greater than 25 mm and equal to or smaller than 100 mm, on a die;

15 performing forming by pressing the vertical wall section and the flange section with a bending die while pressing the top sheet section with a pad; and
trimming the margin thickness of the flange section.

20 17. The method according to claim 16, wherein a radius of curvature of a maximum curvature portion of the curve of the vertical wall section is equal to or greater than 5 mm and equal to or smaller than 300 mm.

18. The method according to claim 16 or 17, wherein a pre-processed blank metal sheet is press-formed as the blank metal sheet.

25 19. The method according to any one of claims 16 to 18, wherein a steel sheet having a breaking strength of equal to or higher than 400 MPa and equal to or lower than 1,600 MPa is used as the blank metal sheet.

20. A forming method of a press component having an L shape, comprising:

30 performing forming by the method according to any one of claims 16 to 19 to form a shape of a single L character, a shape of a plurality of L characters, or a shape of any L character, when a shape having a plurality of L characters is press-formed.

FIG. 1

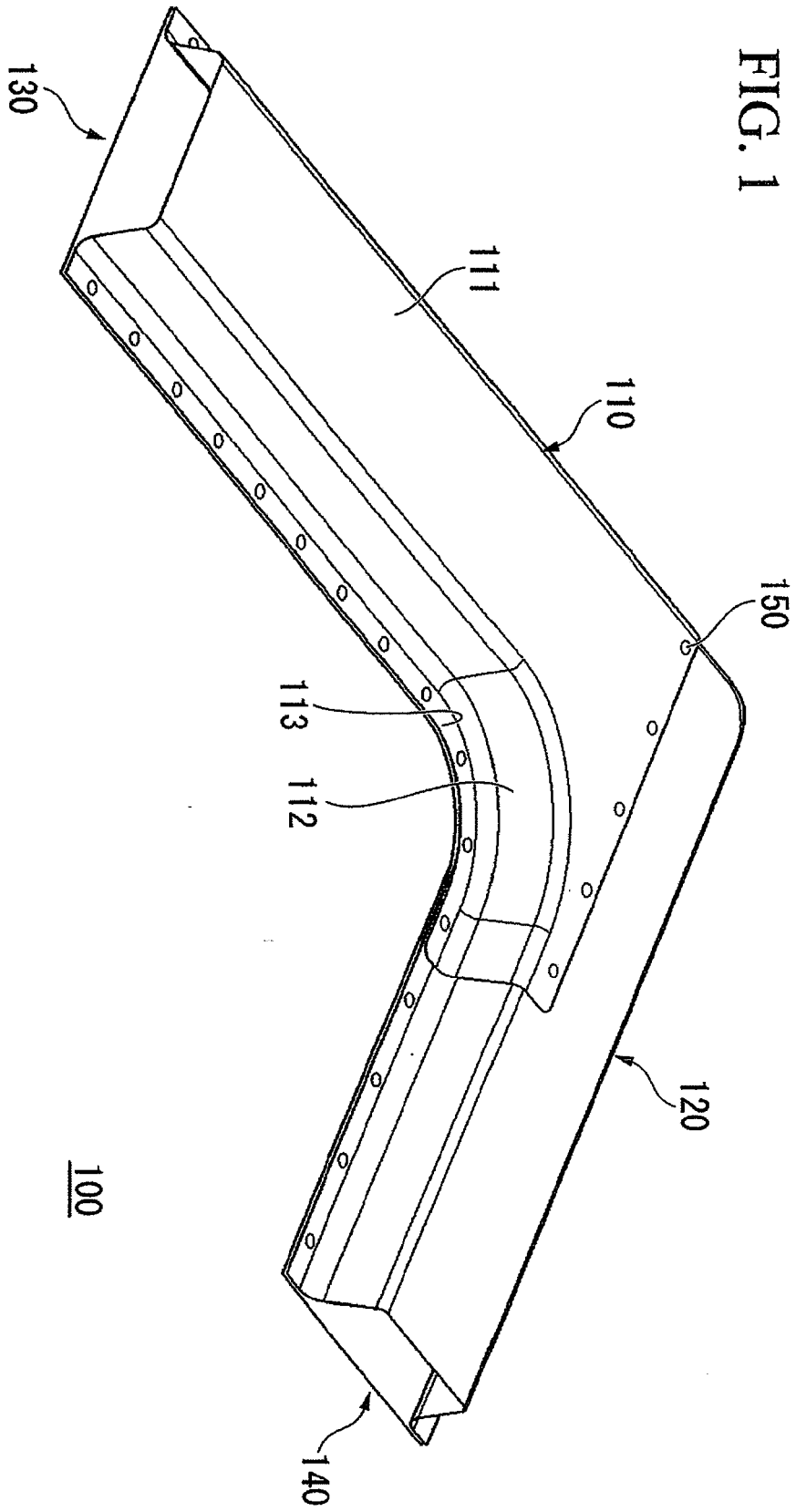
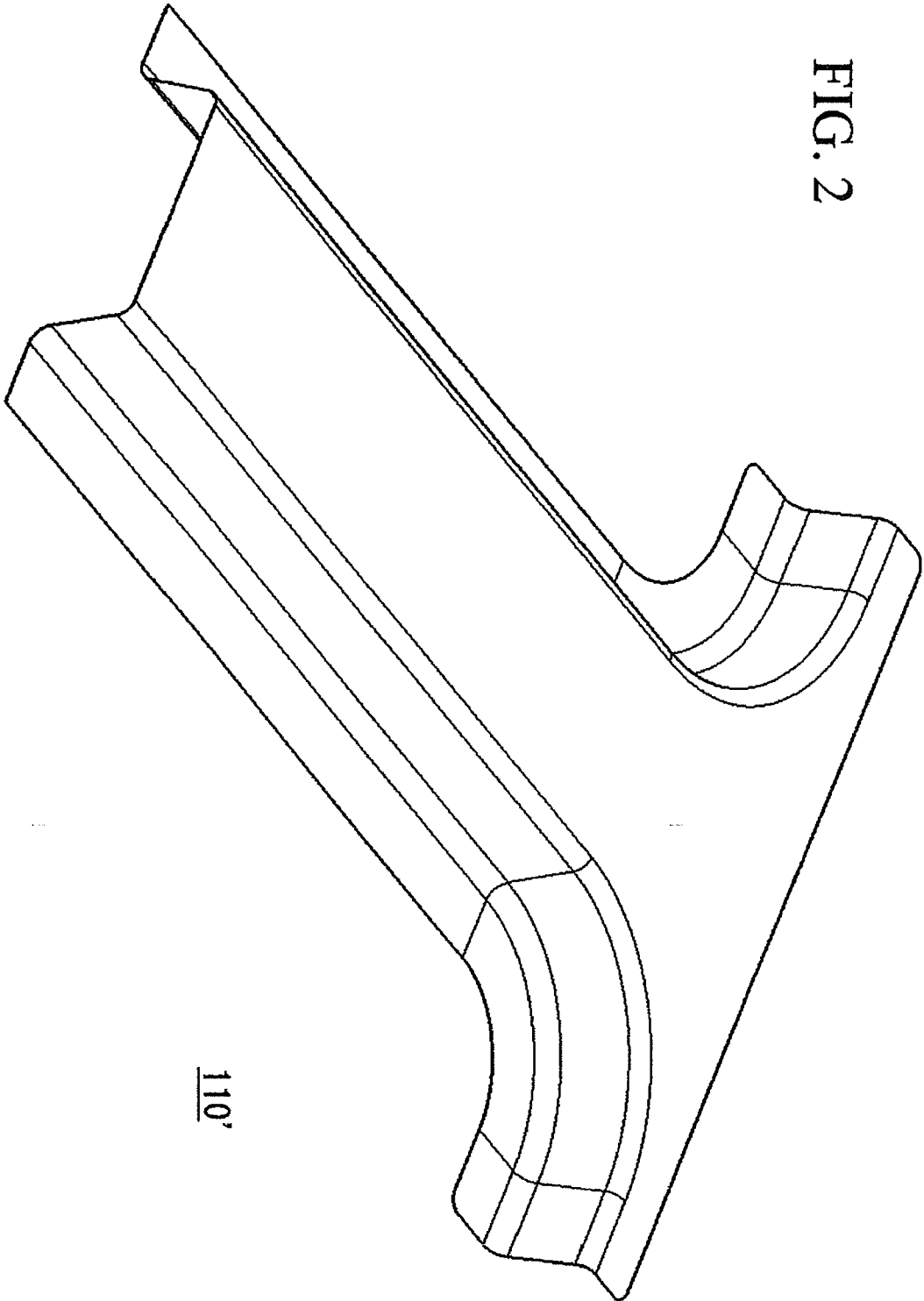

FIG. 2



110'

FIG. 3

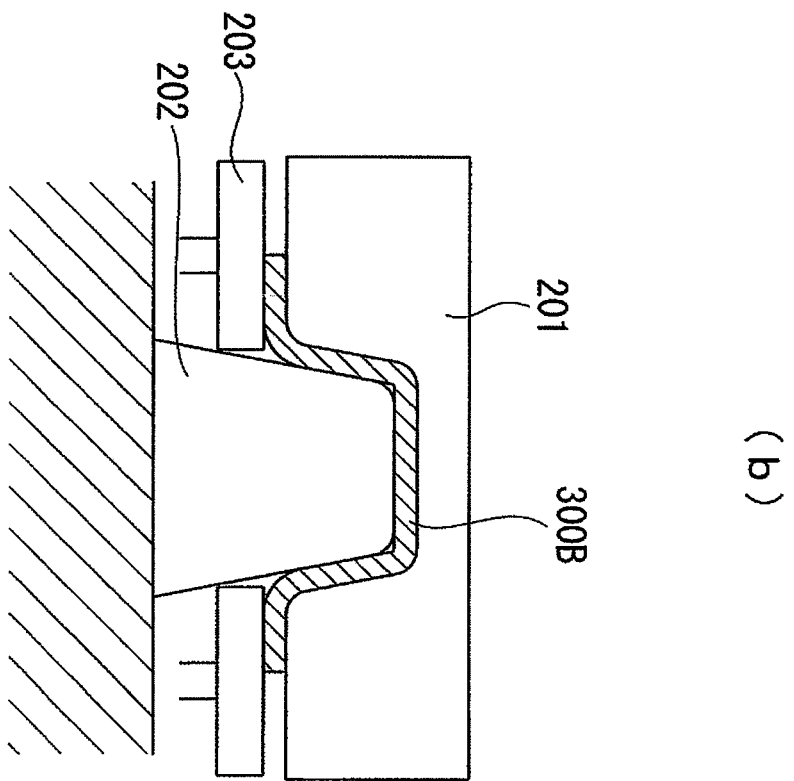
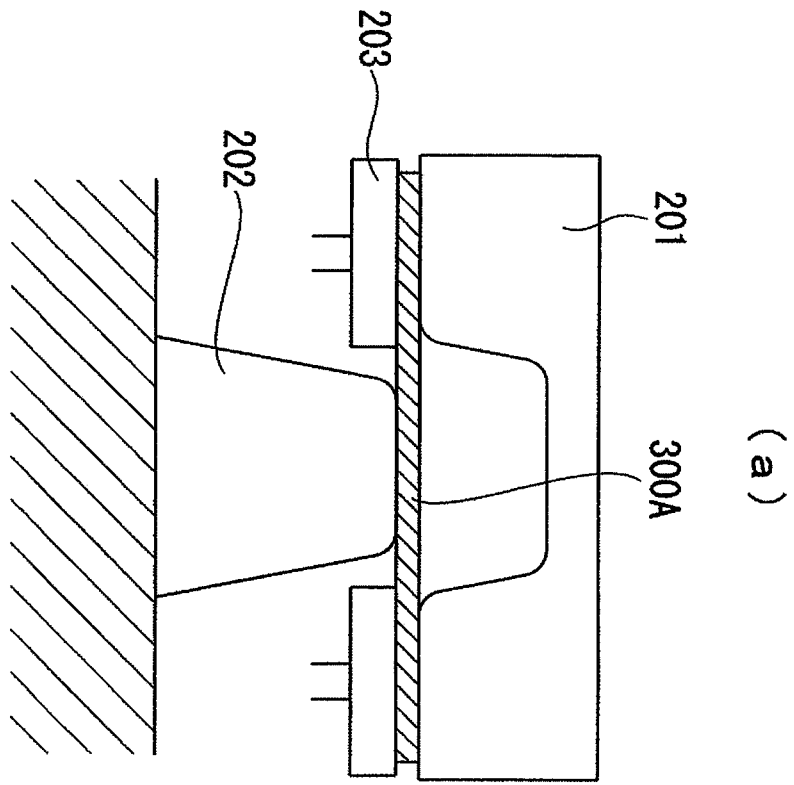

FIG. 4A

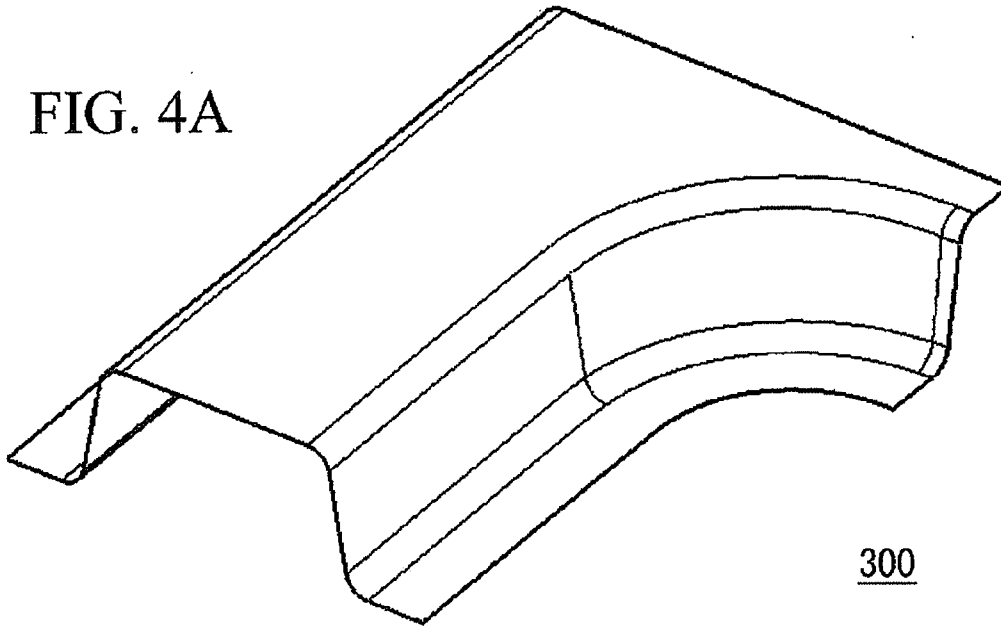

FIG. 4B

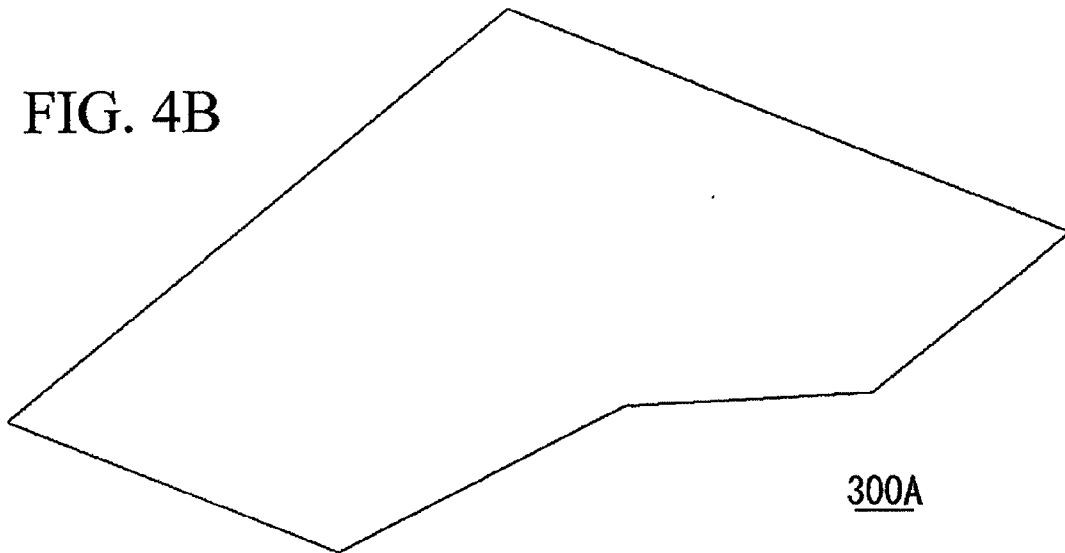
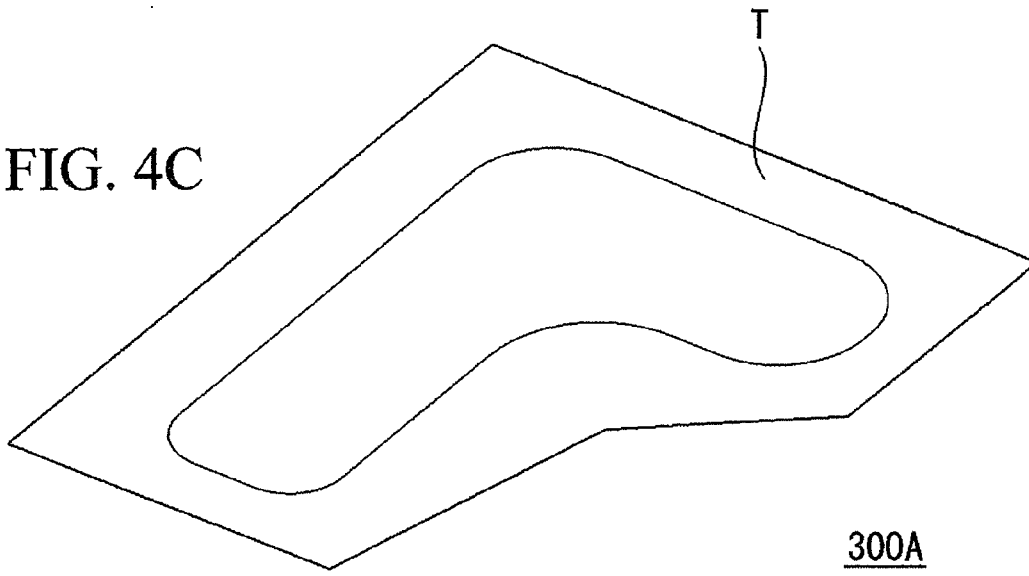
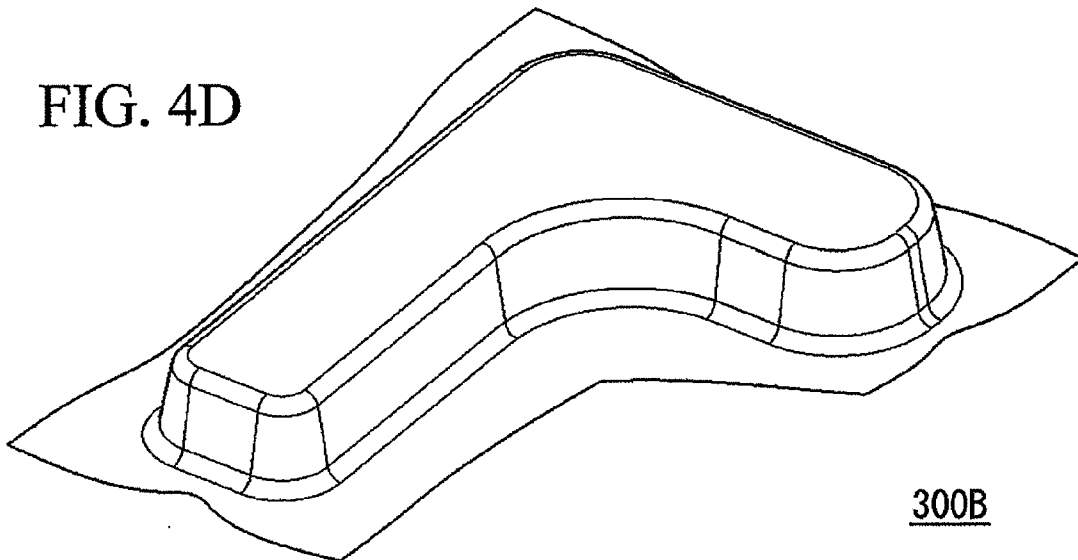

FIG. 4C



300A

FIG. 4D



300B

FIG. 5

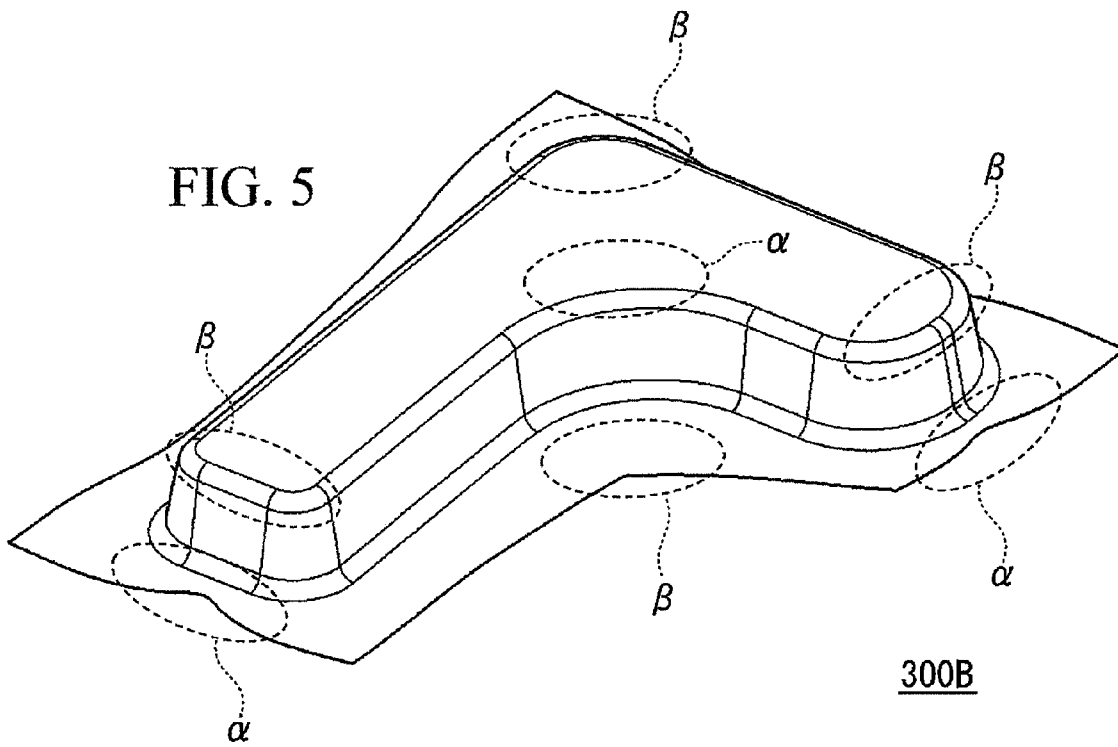

FIG. 6

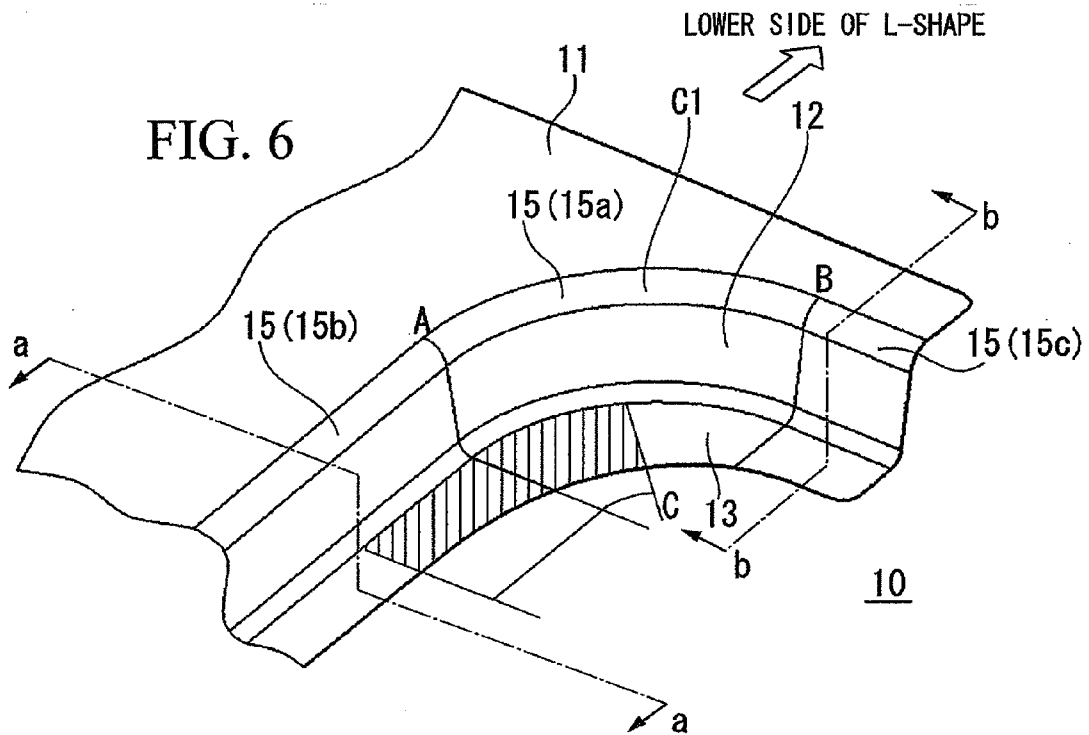
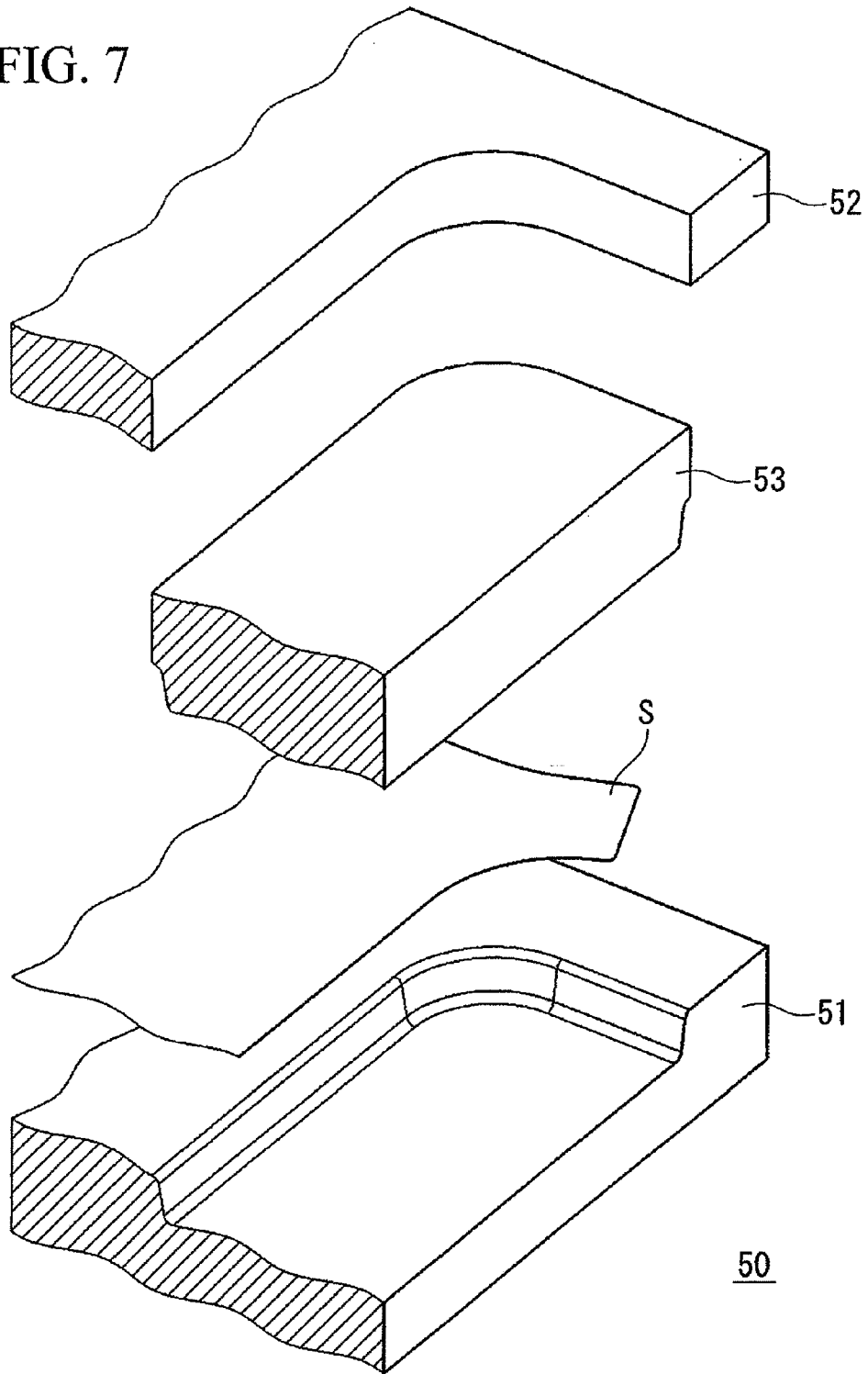

FIG. 7



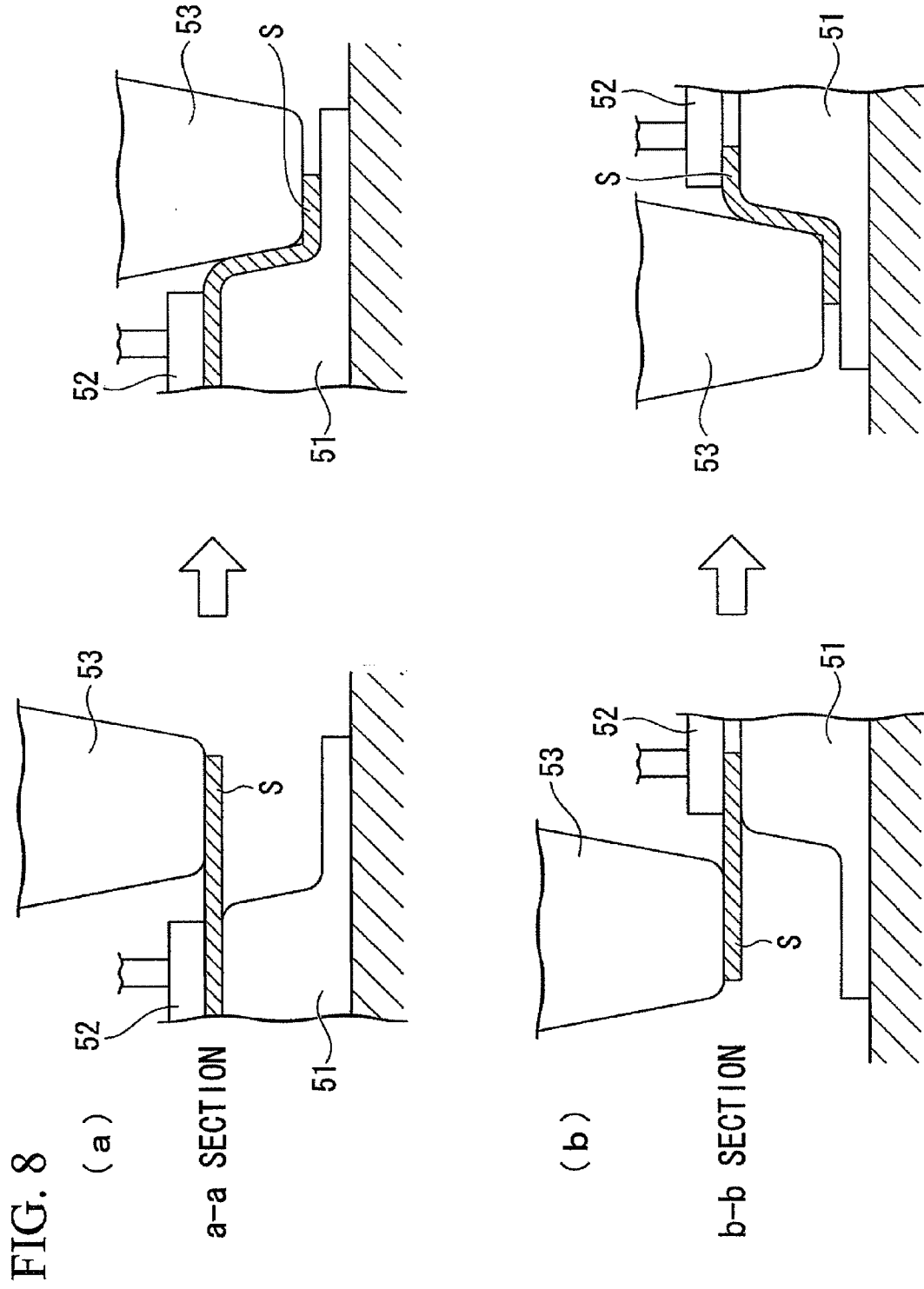

FIG. 9A

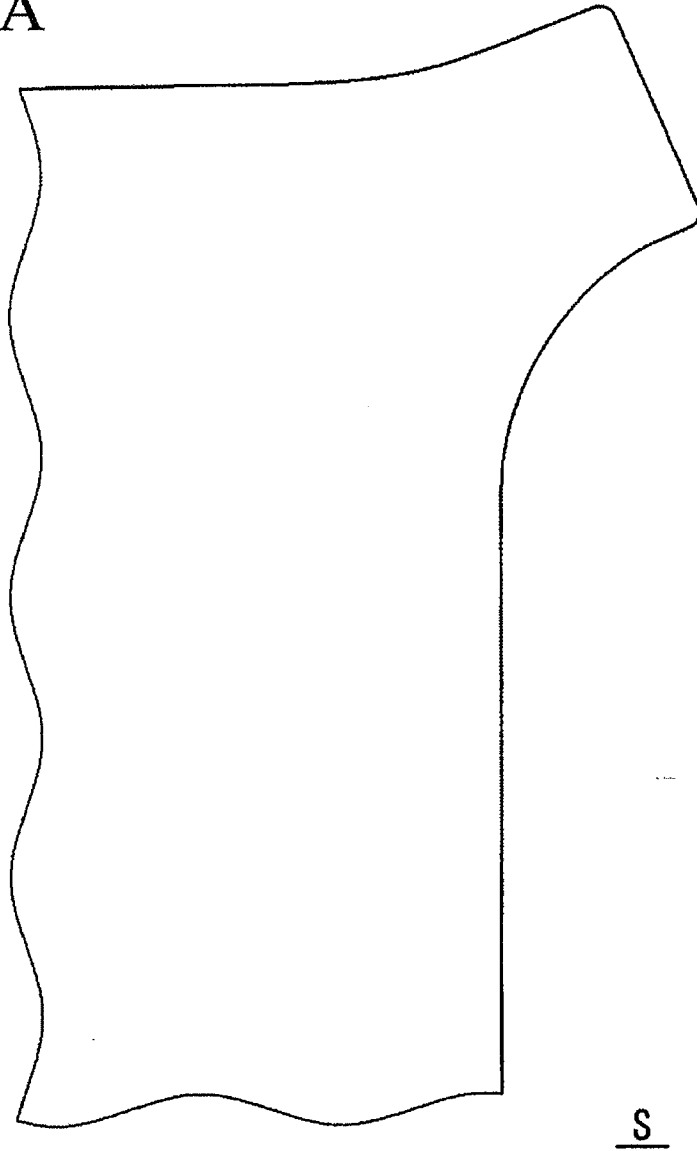

FIG. 9B

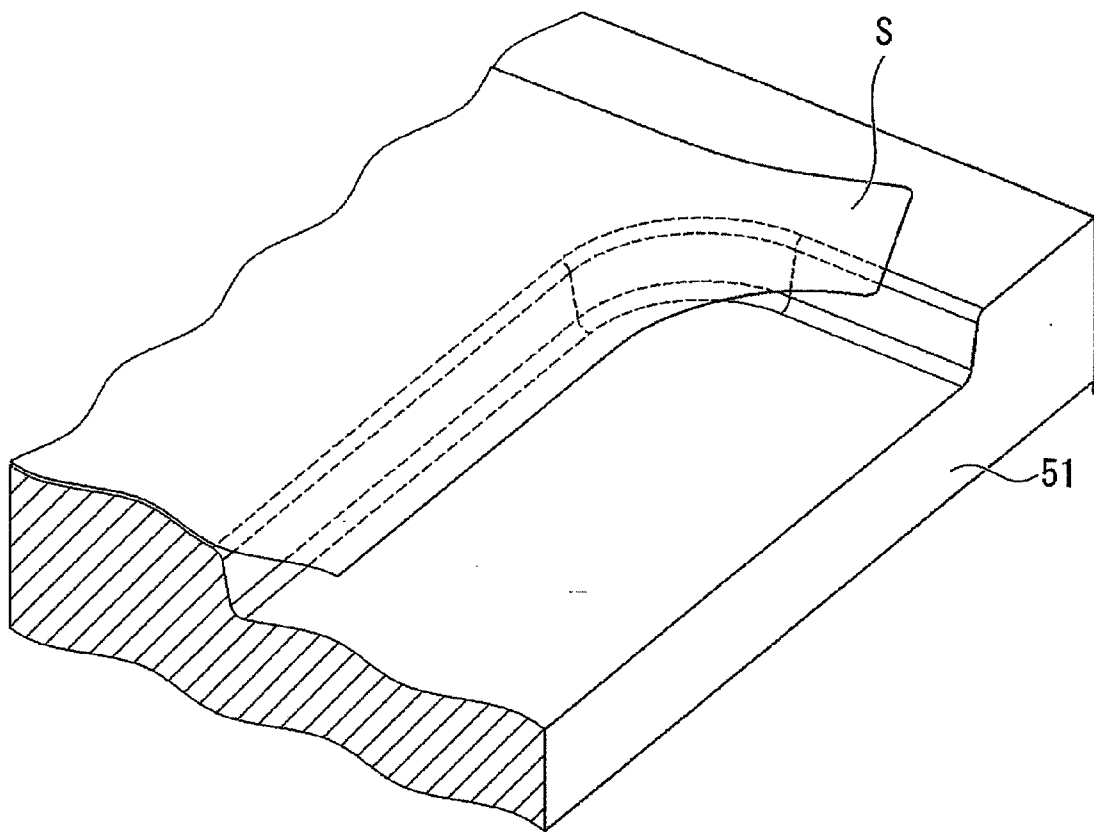

FIG. 9C

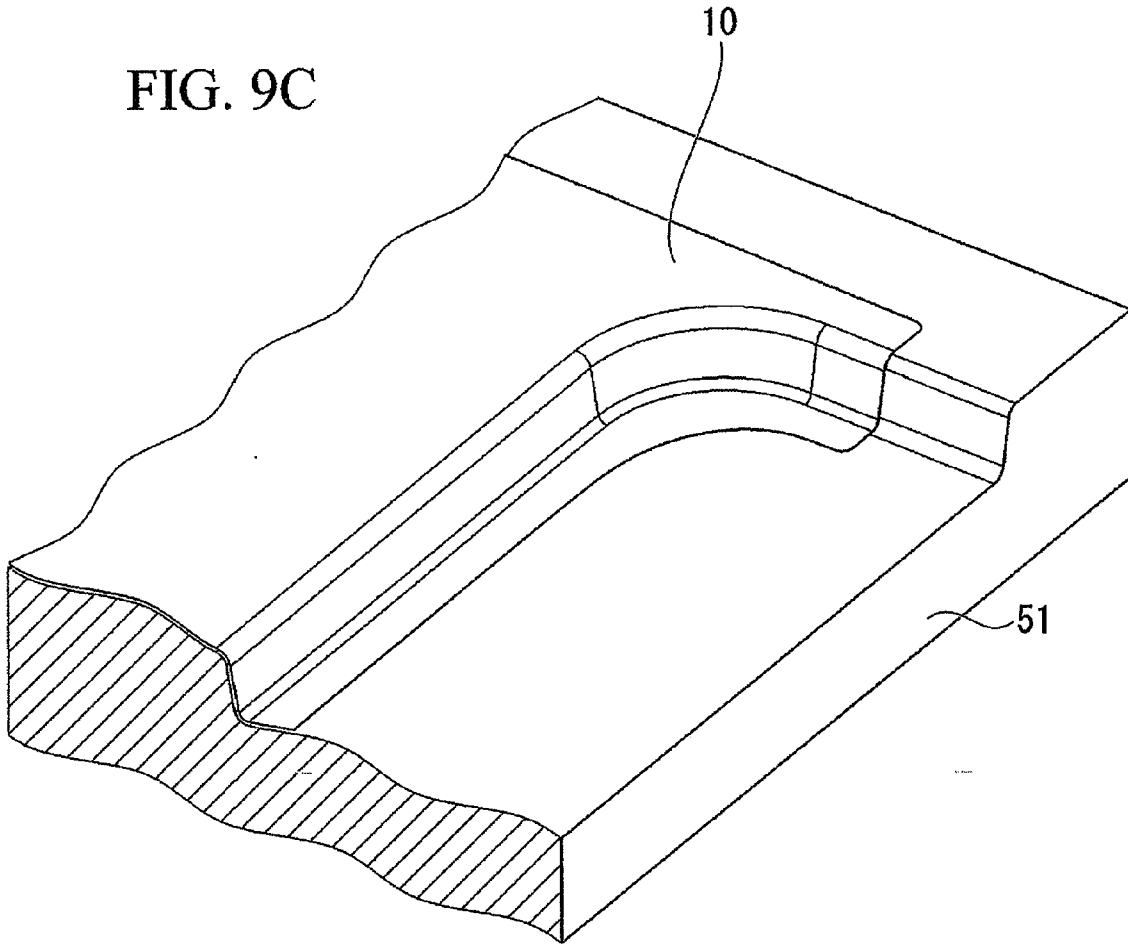
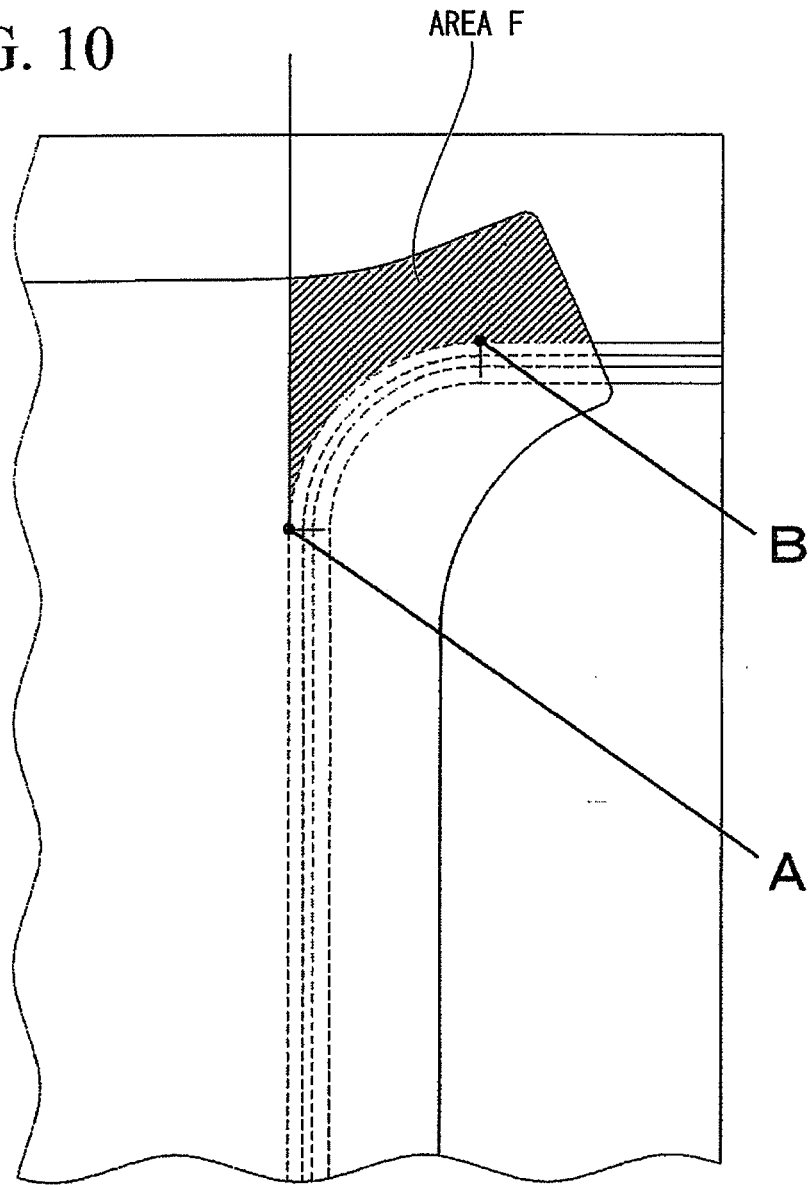

FIG. 10



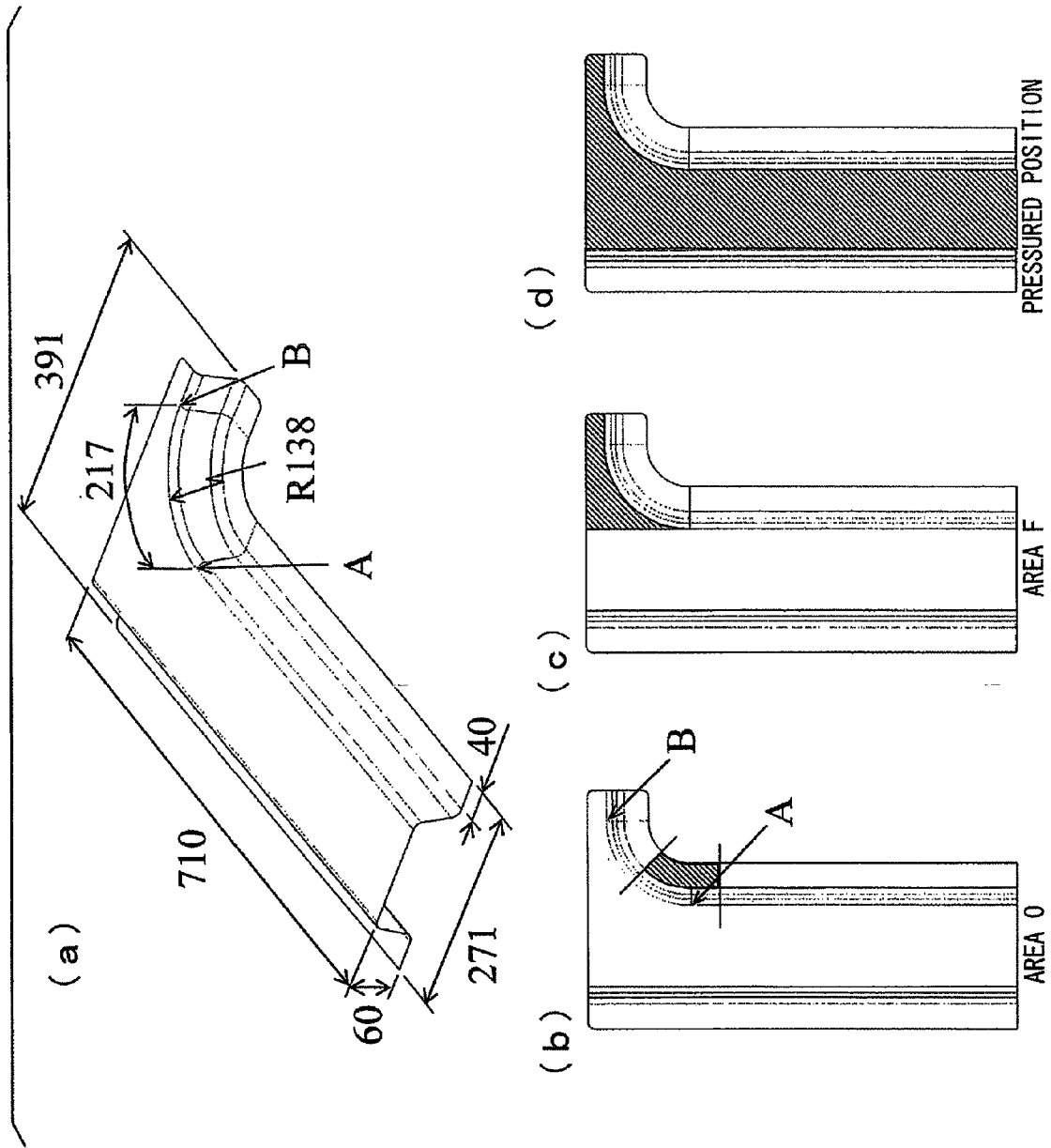

FIG. 11

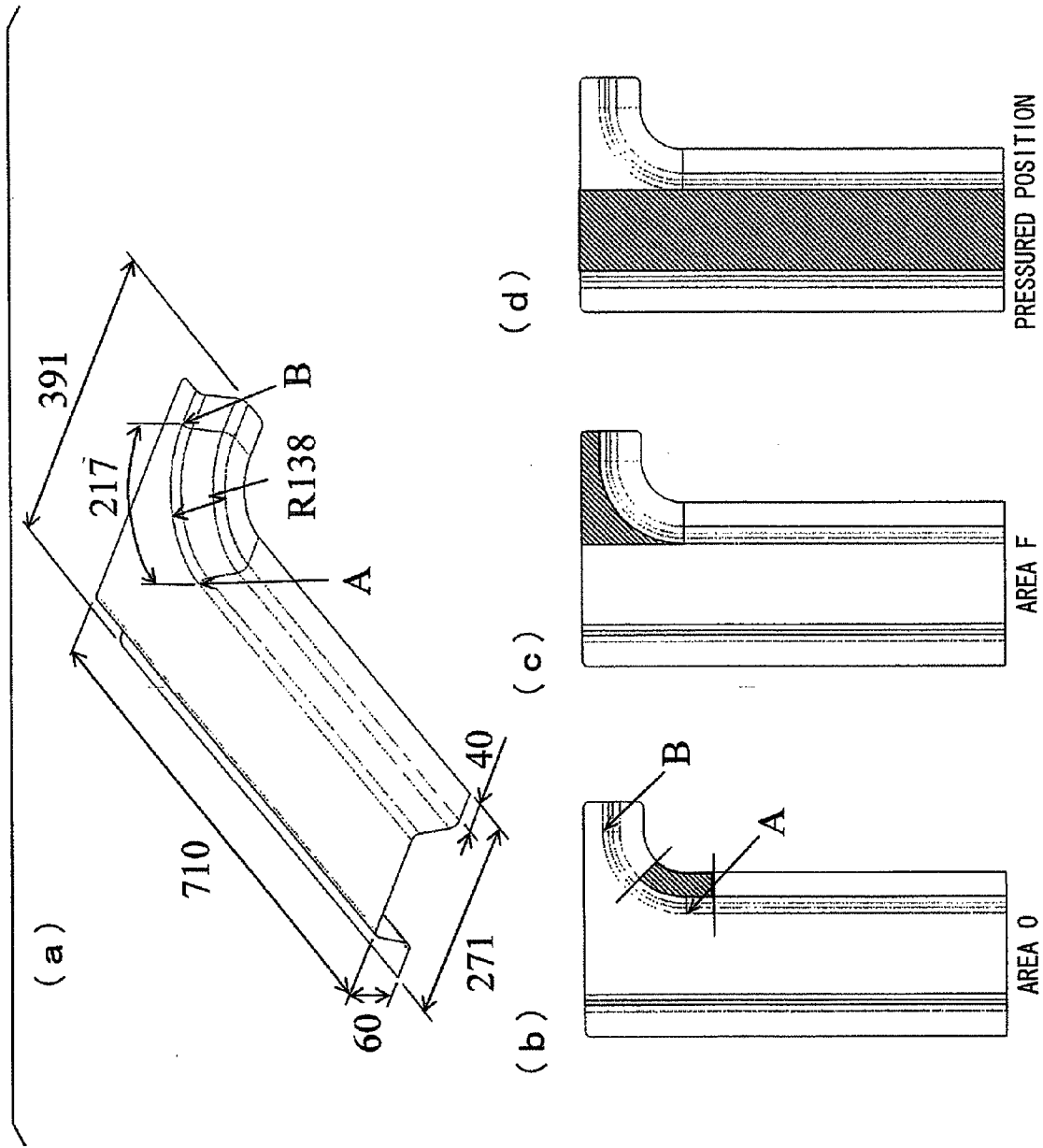
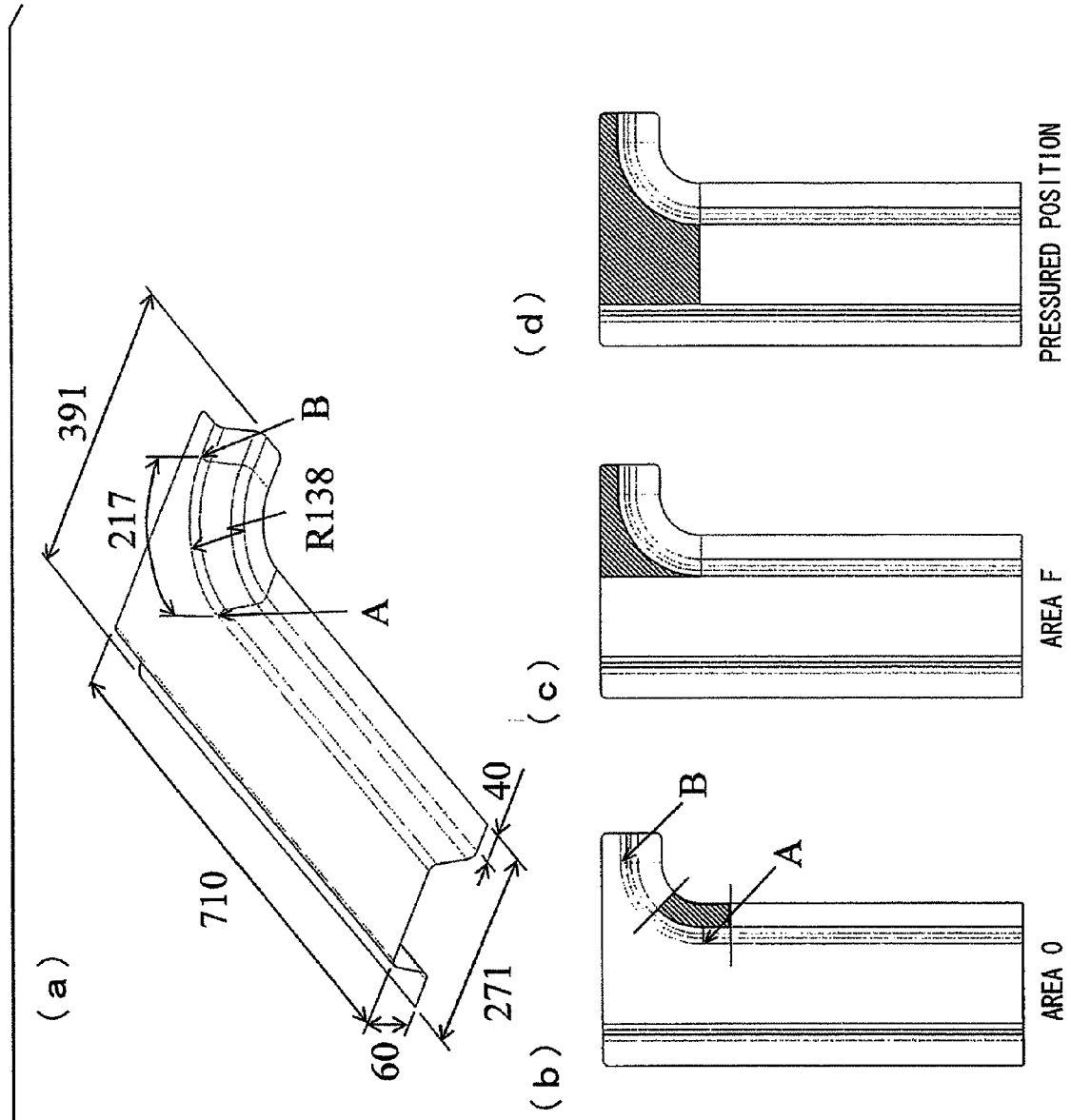

FIG. 12



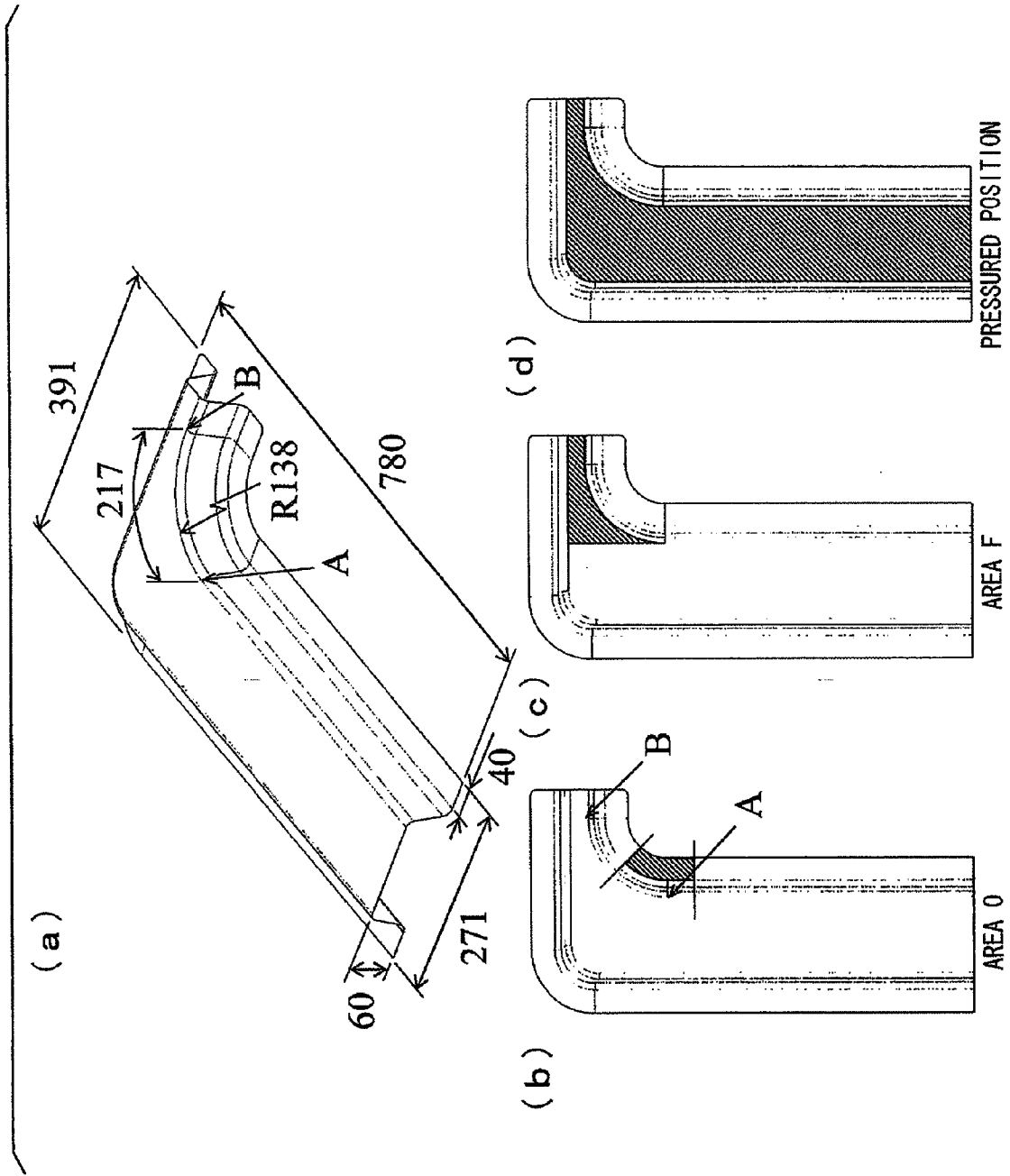

FIG. 14

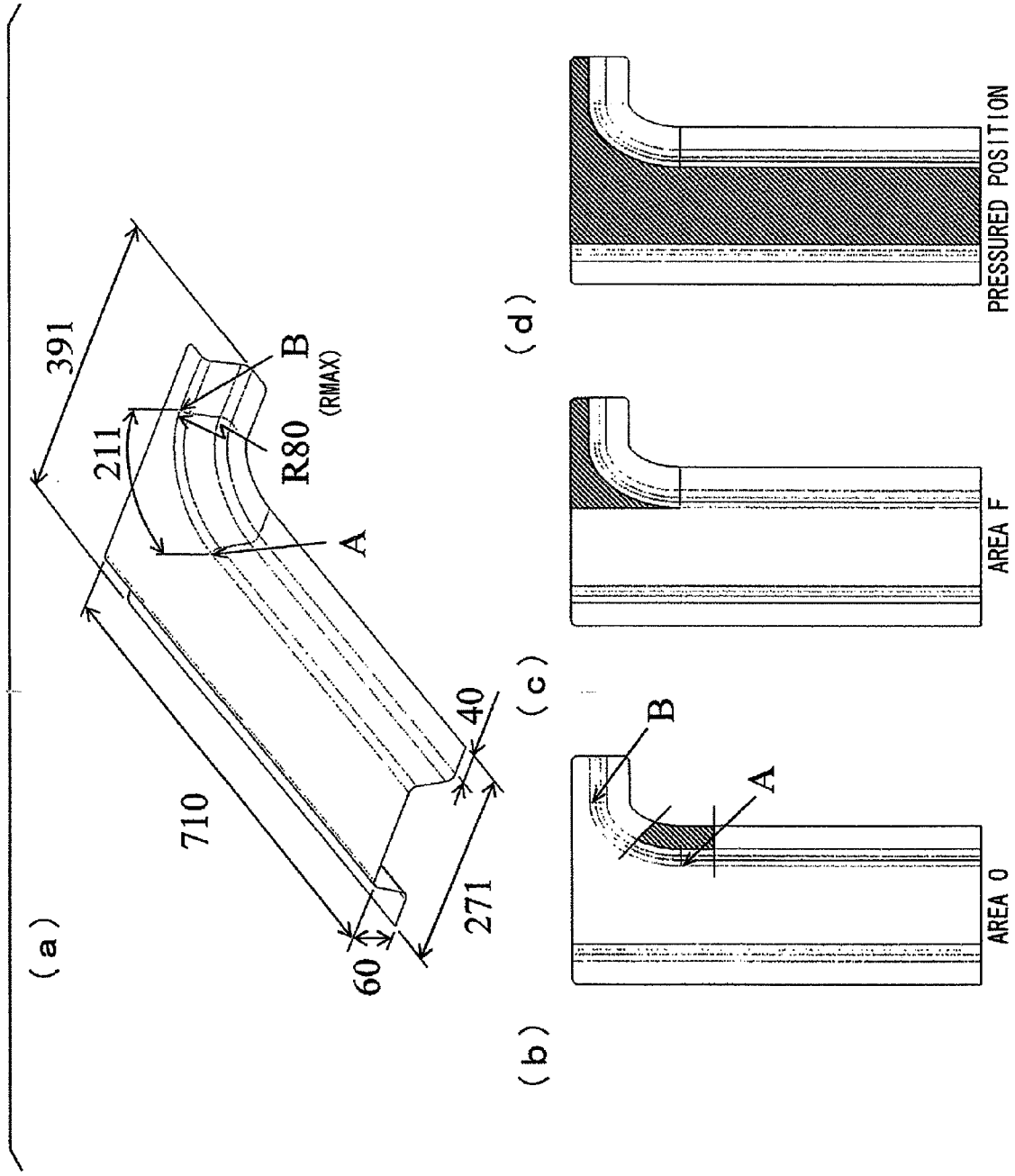
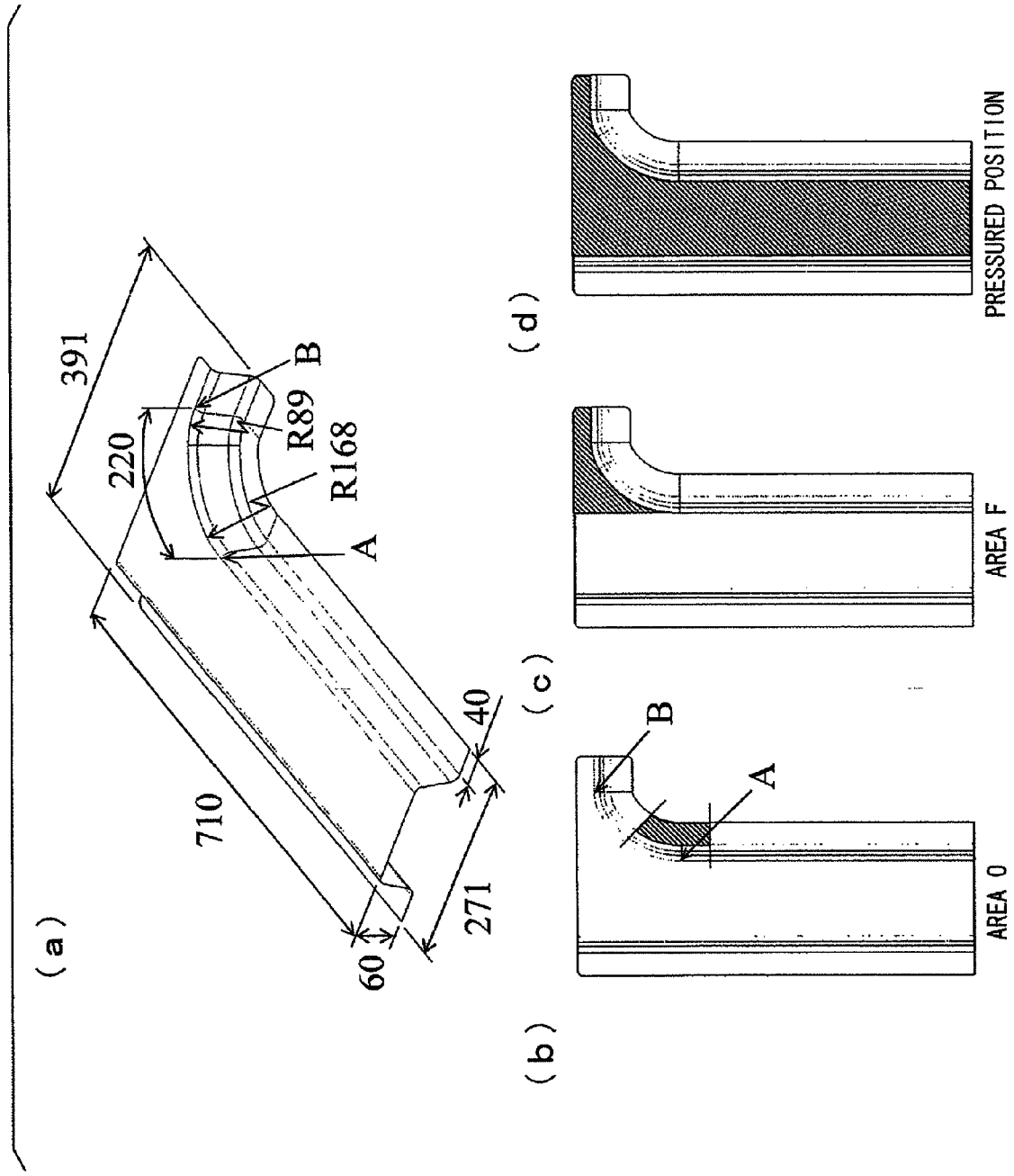

FIG. 15



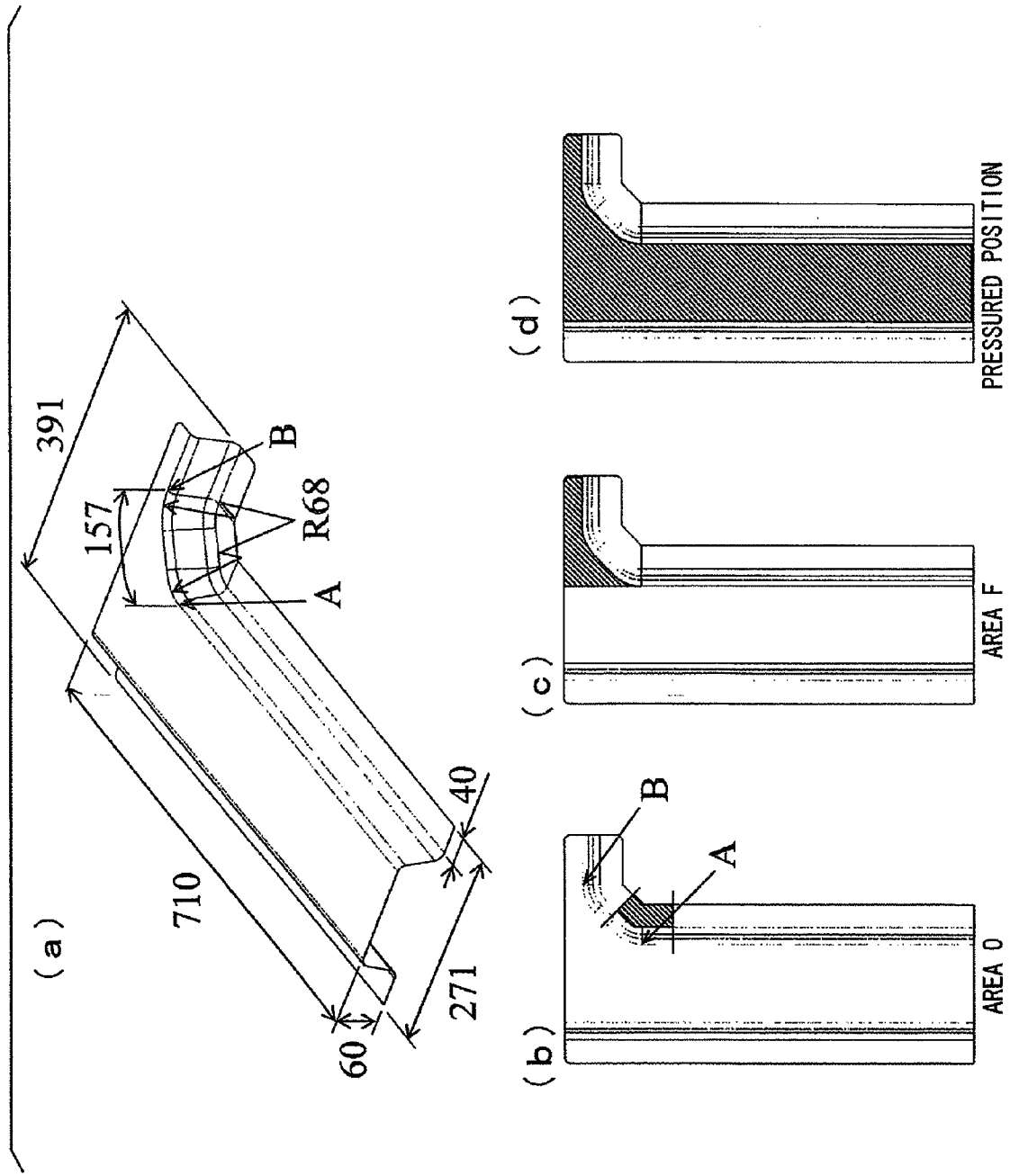

FIG. 17

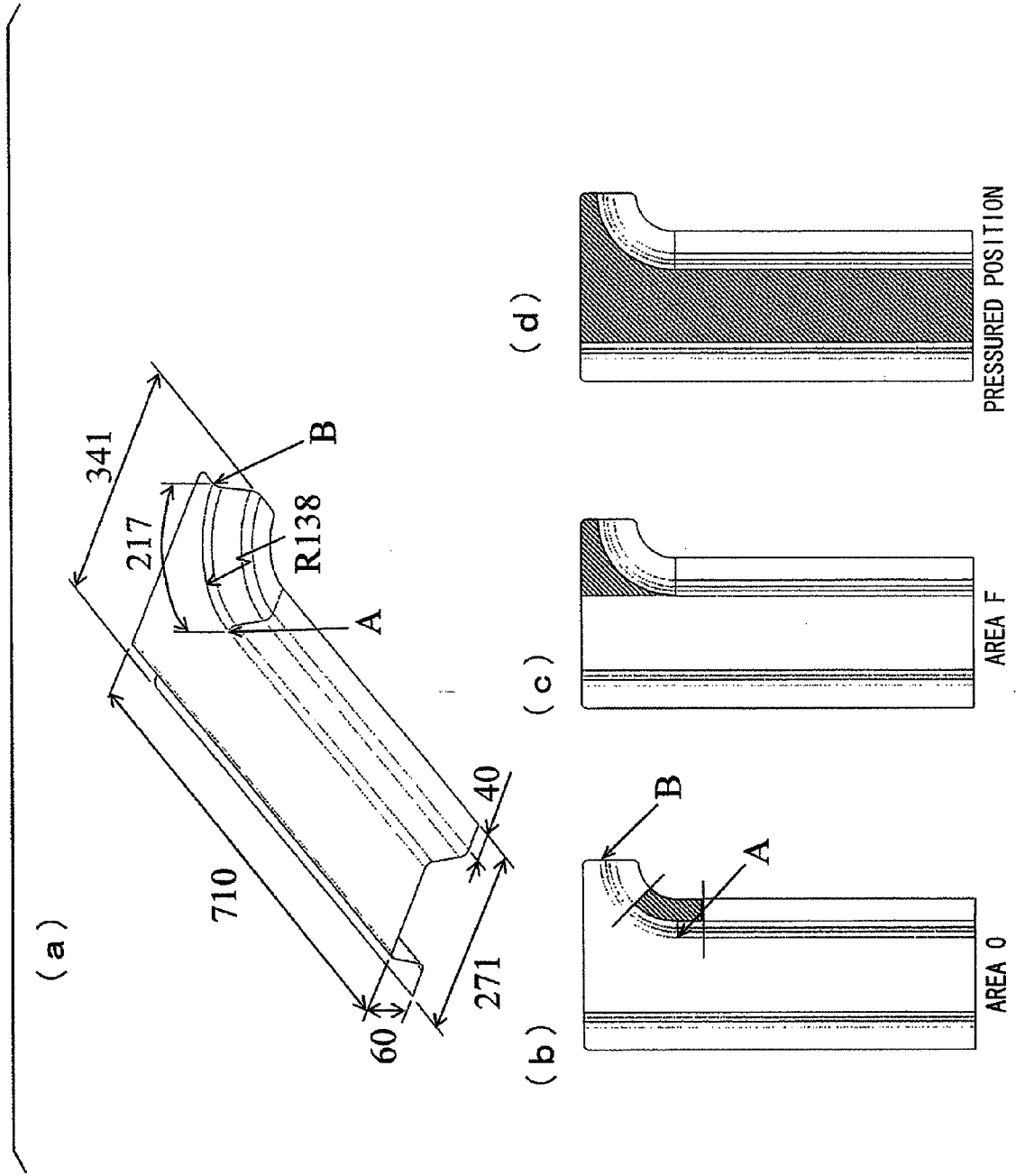
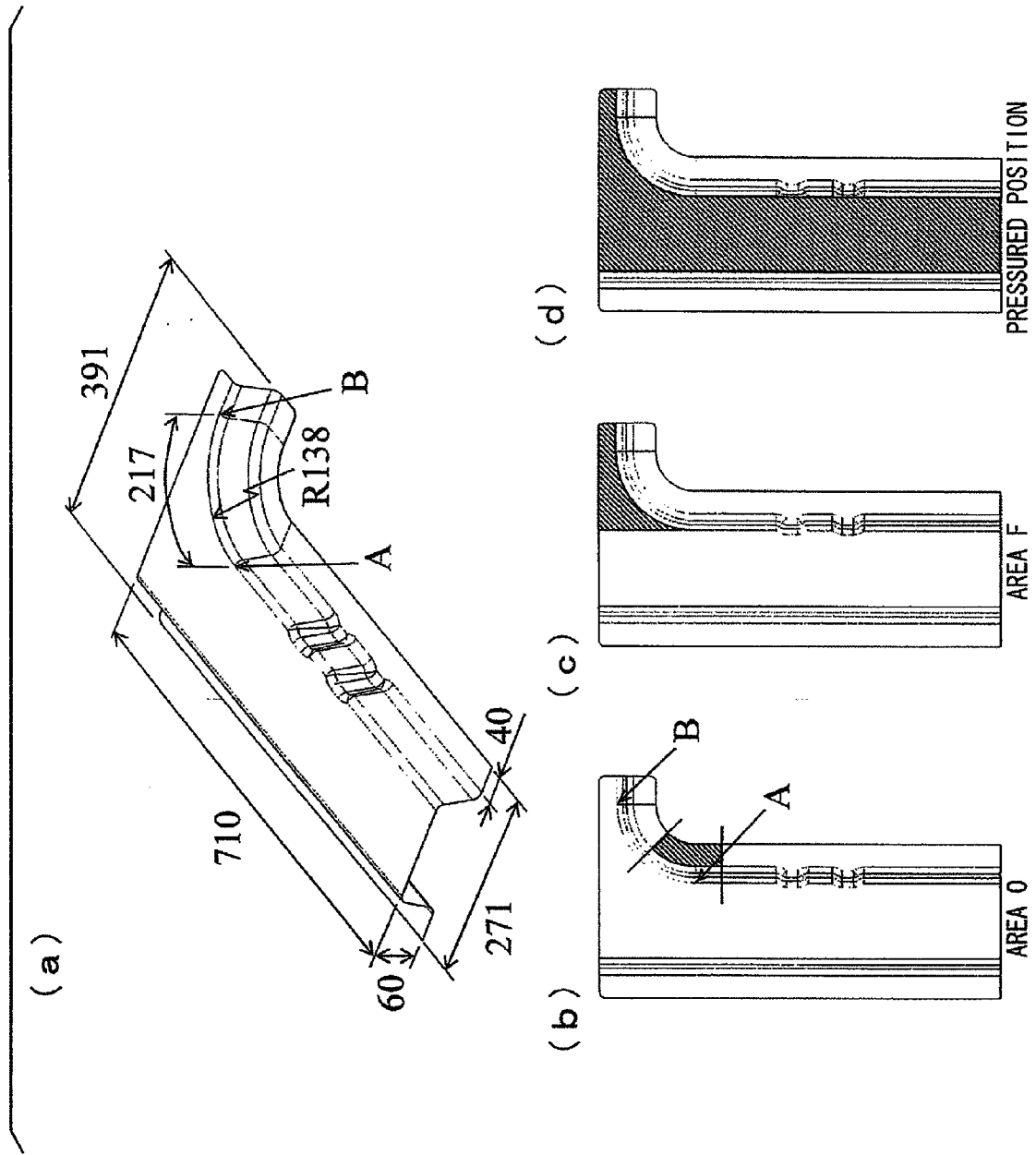

FIG. 18



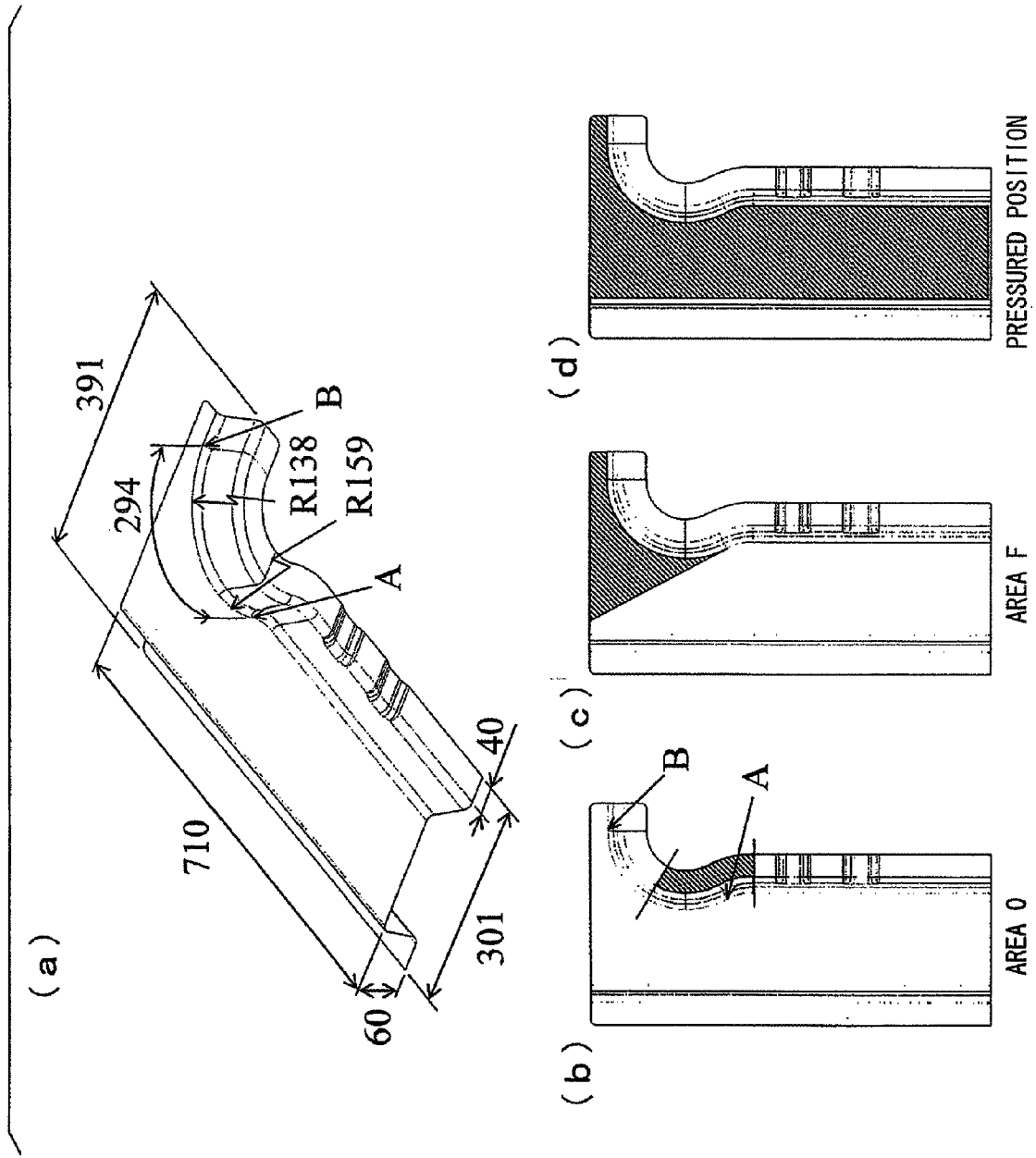

FIG. 20

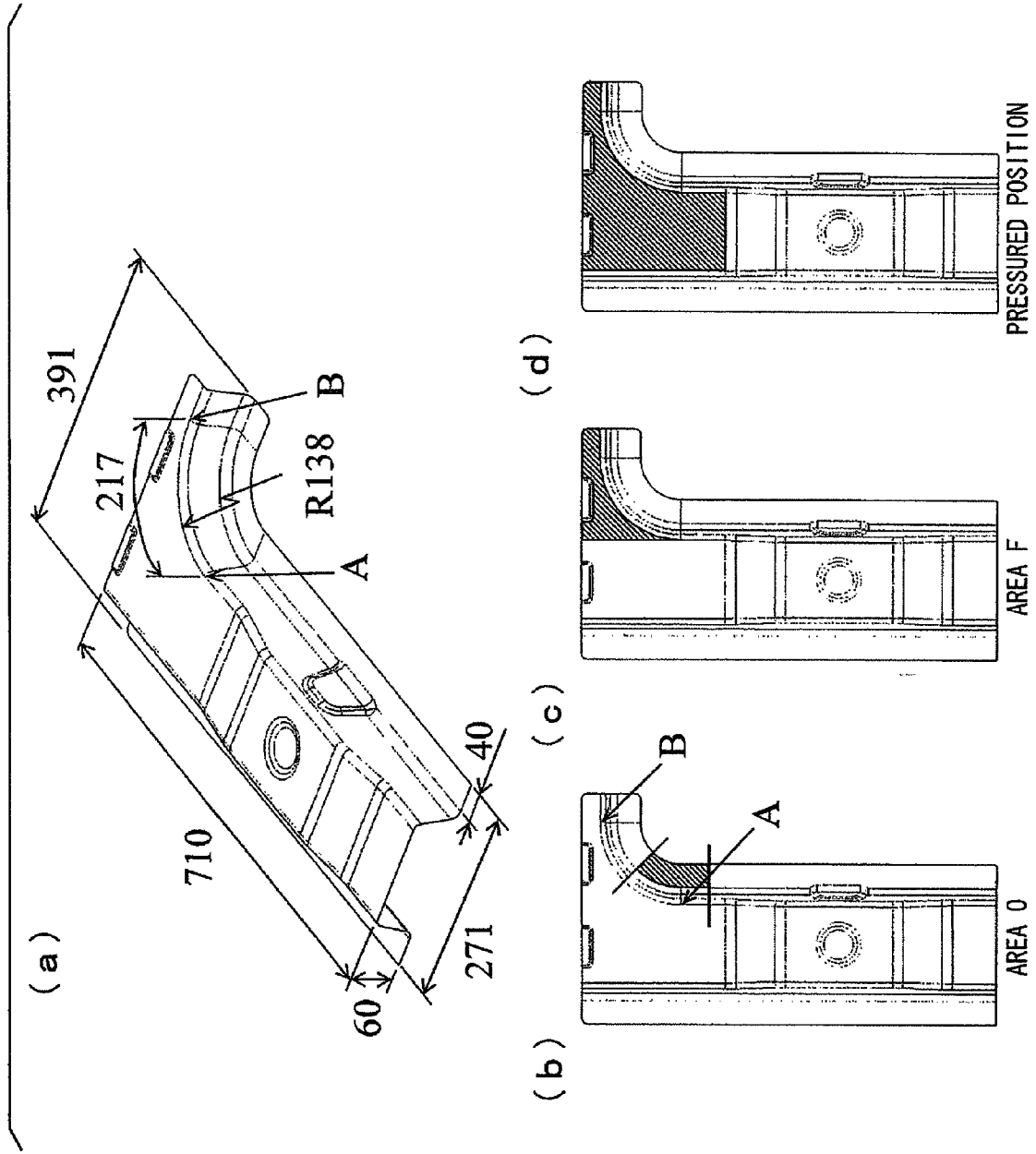

FIG. 21

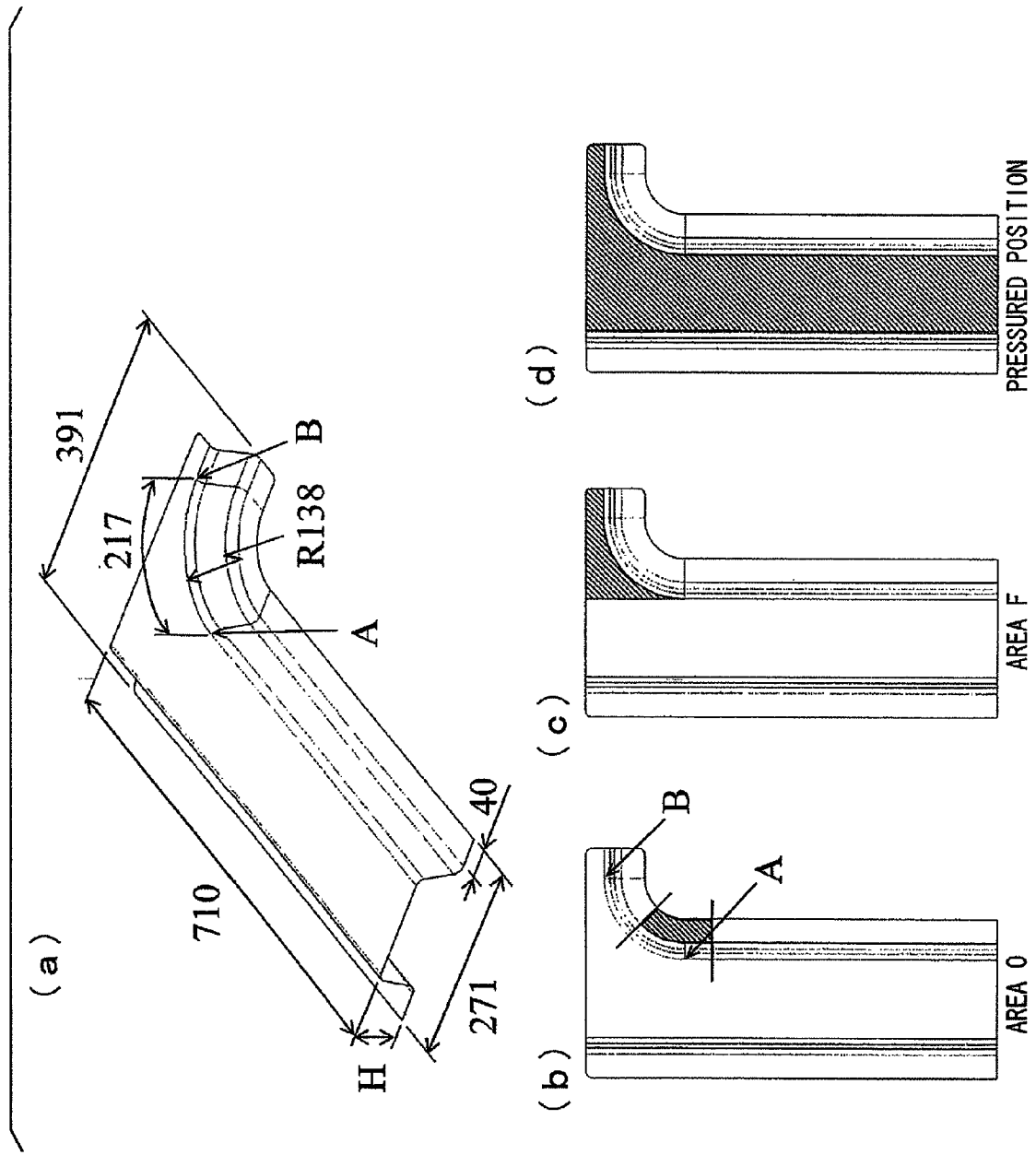

FIG. 22

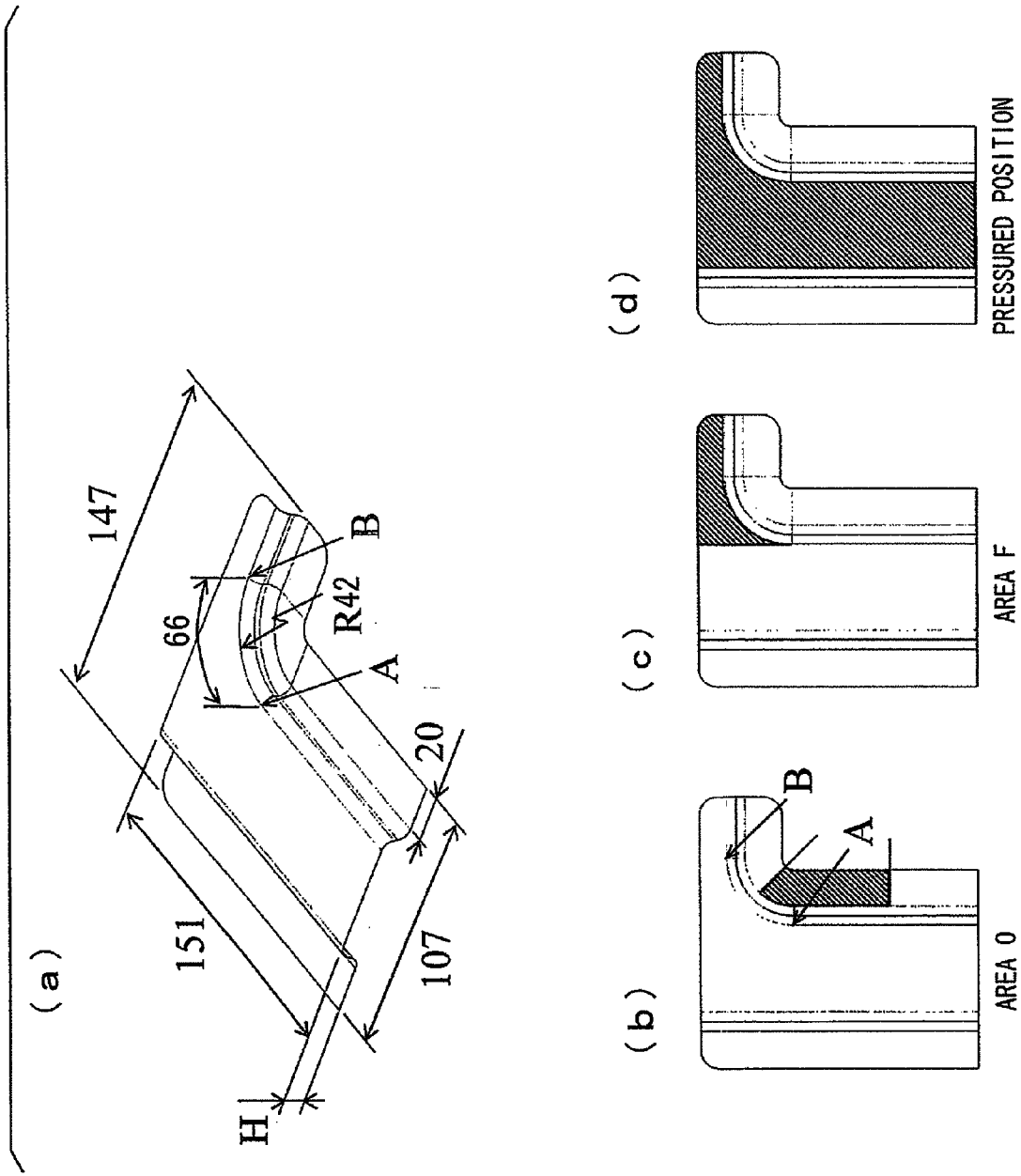

FIG. 23

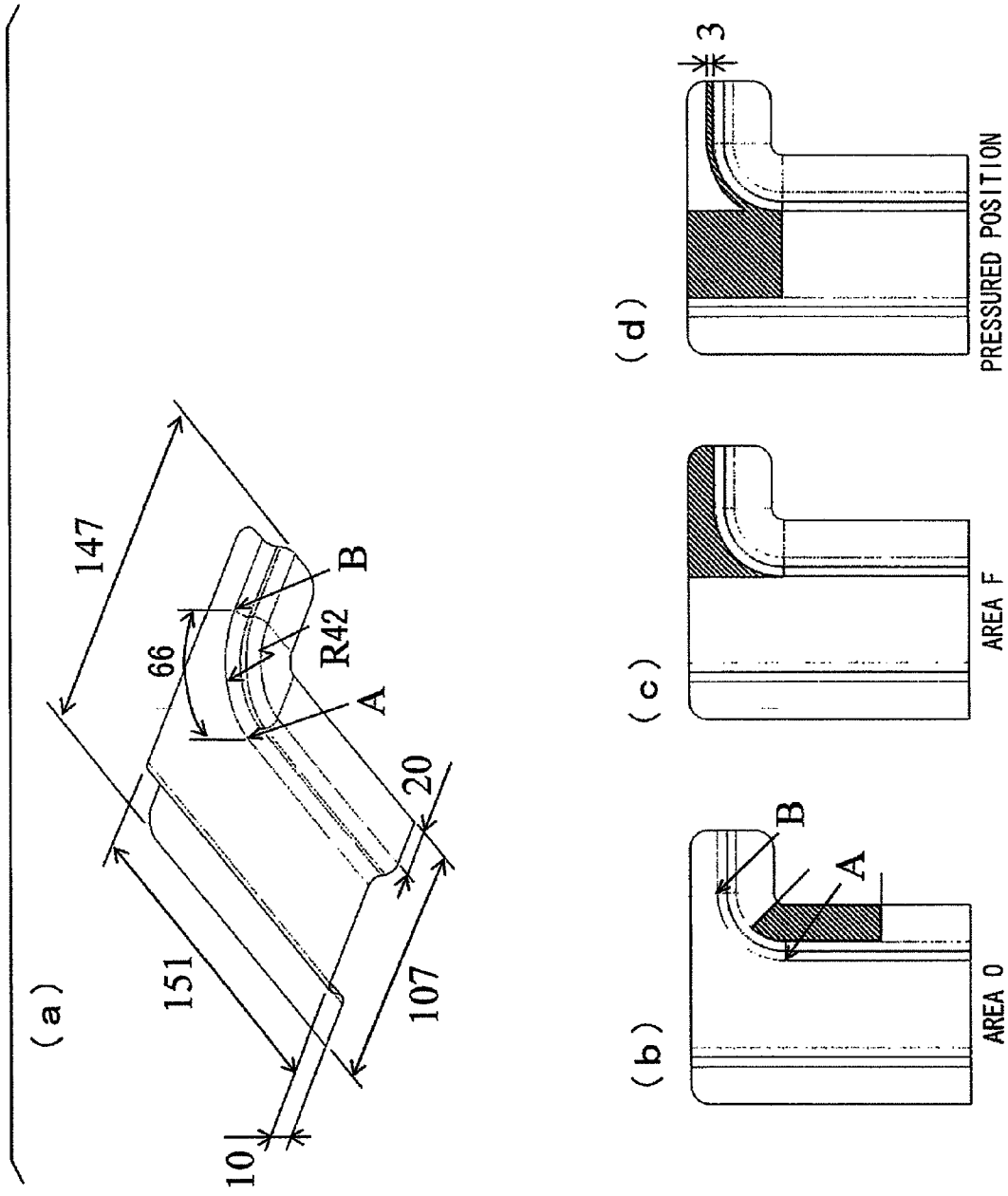

FIG. 24

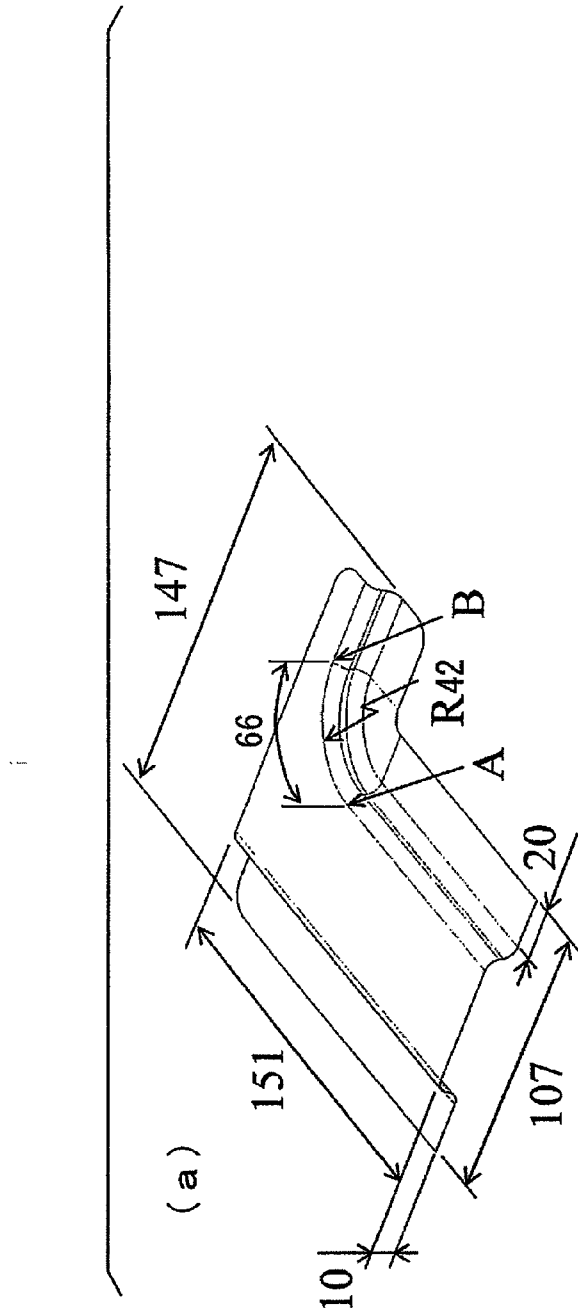
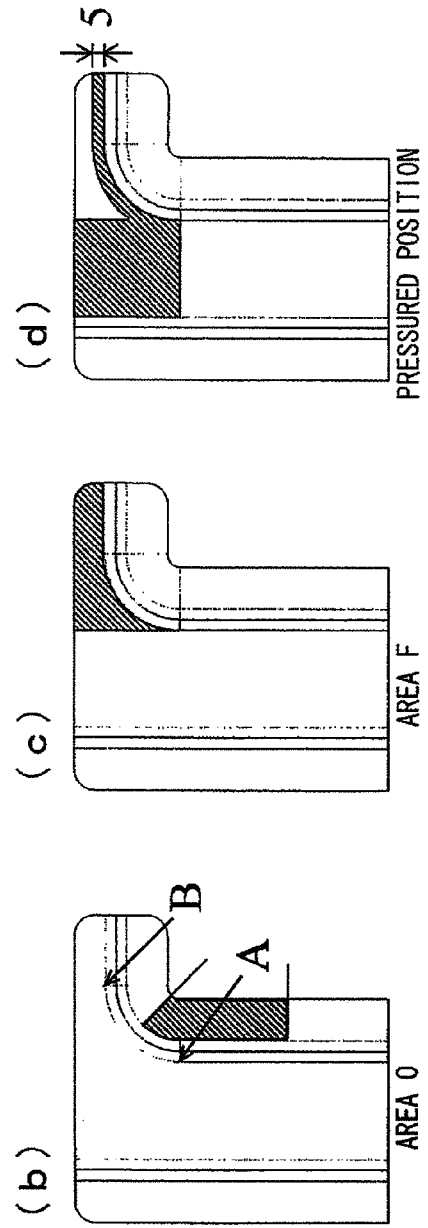
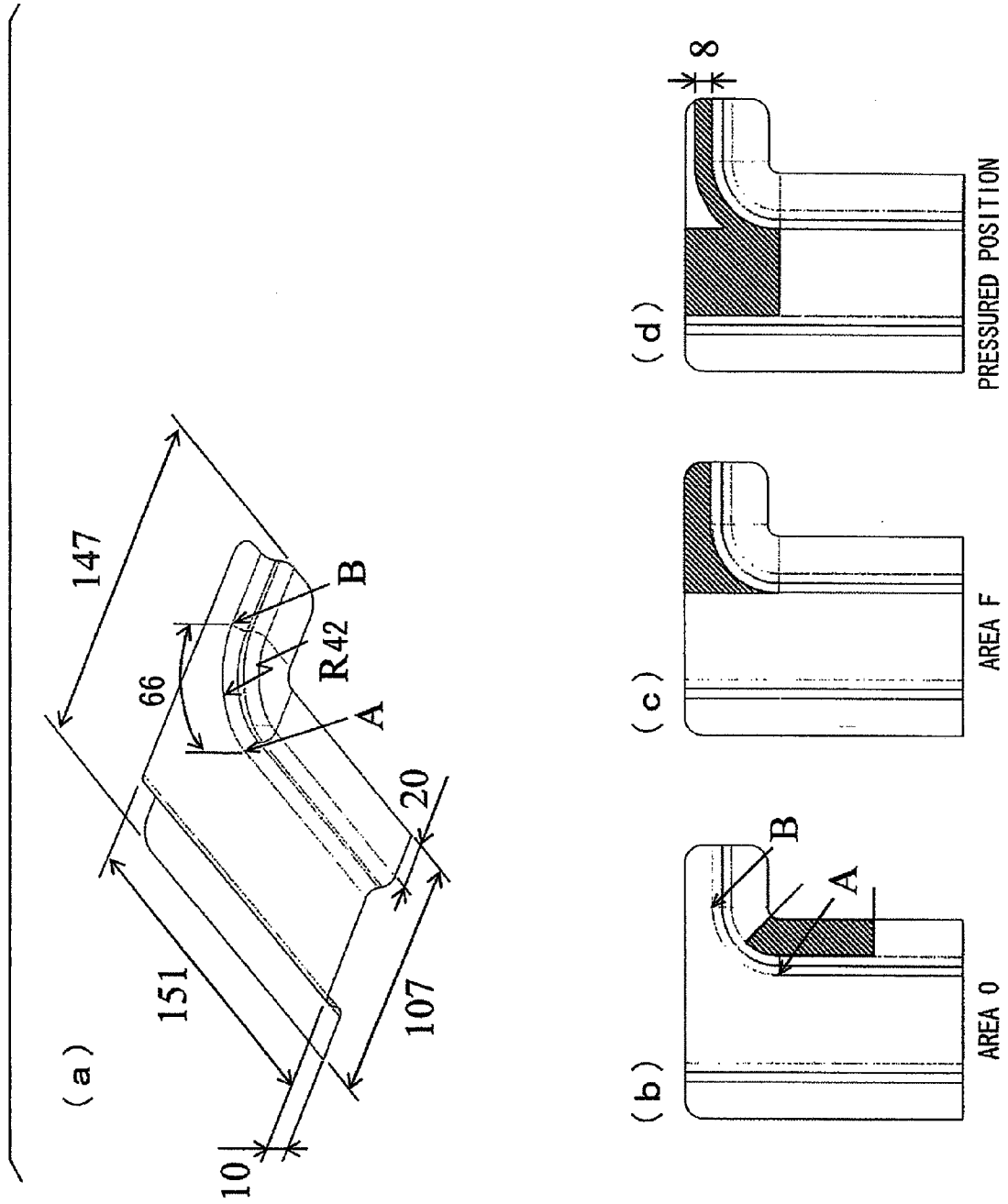
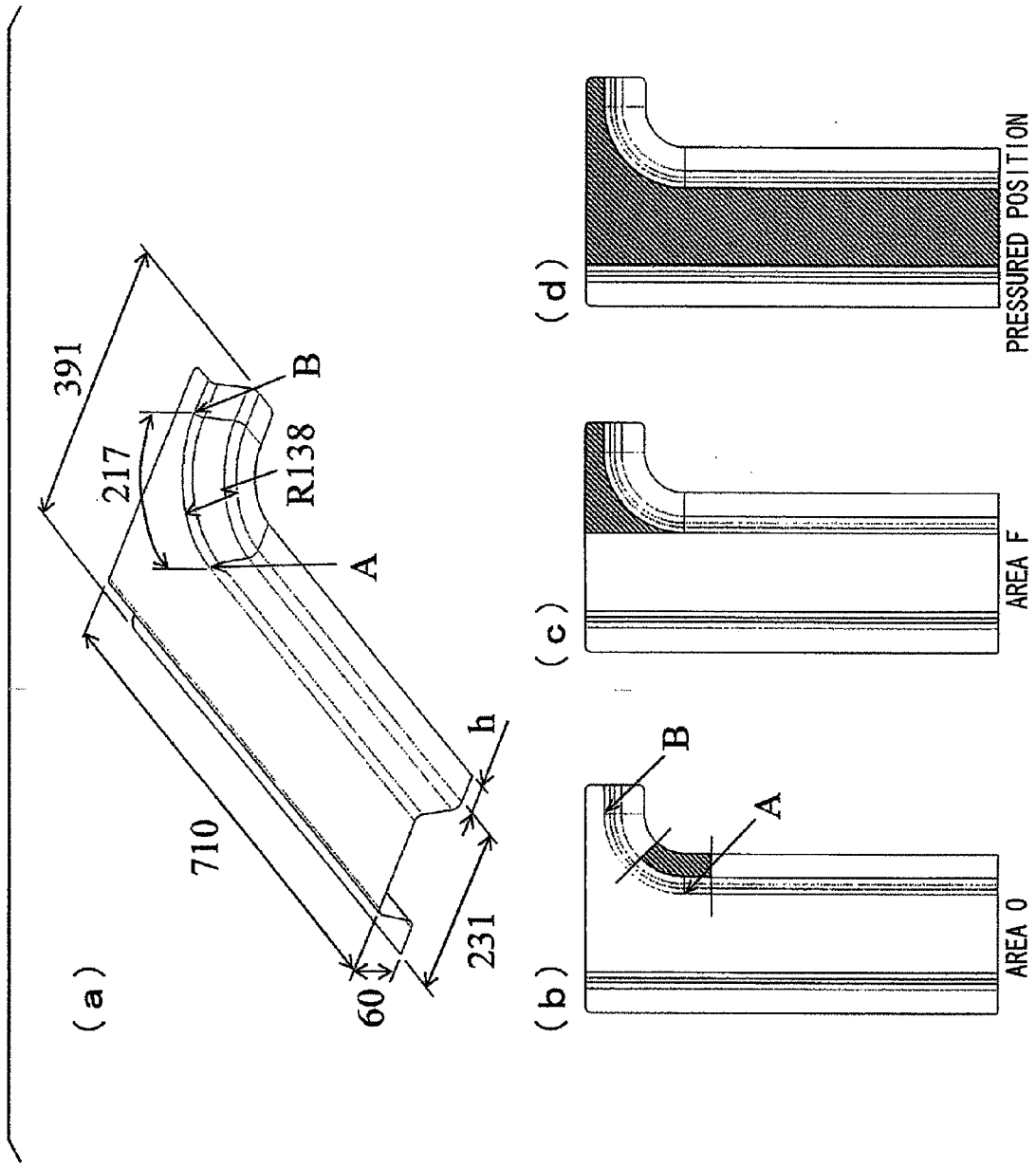

FIG. 25







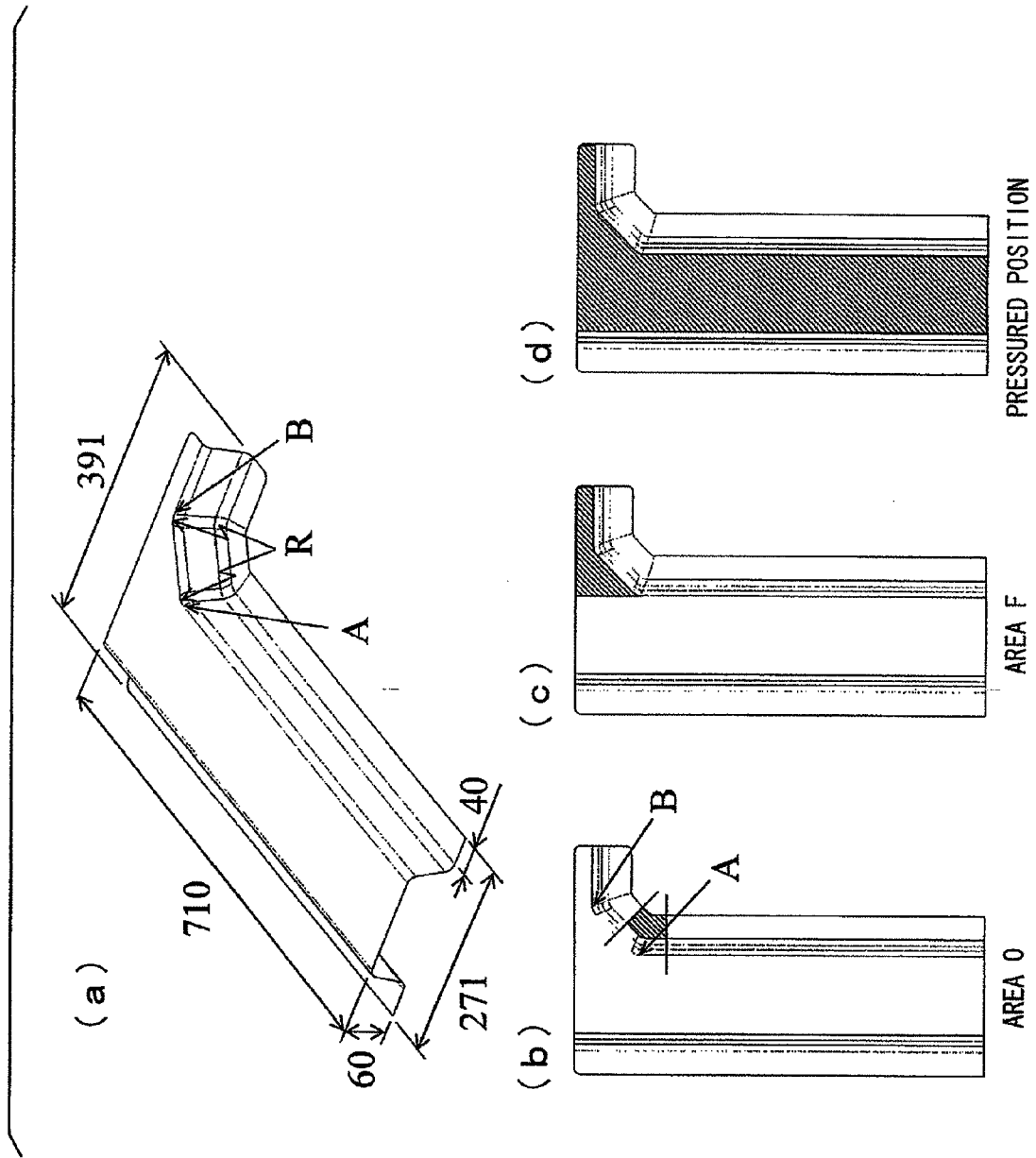

FIG. 28

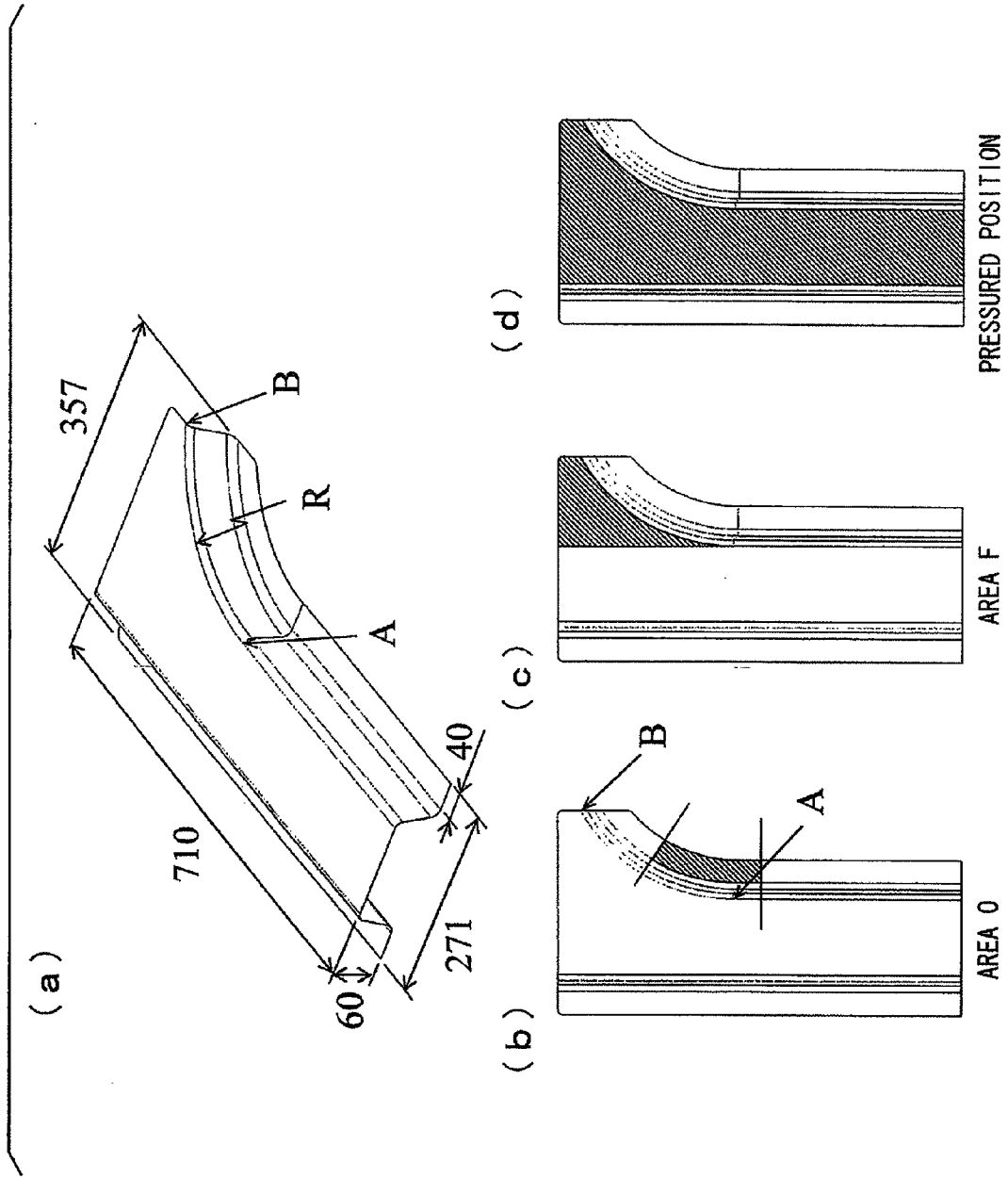
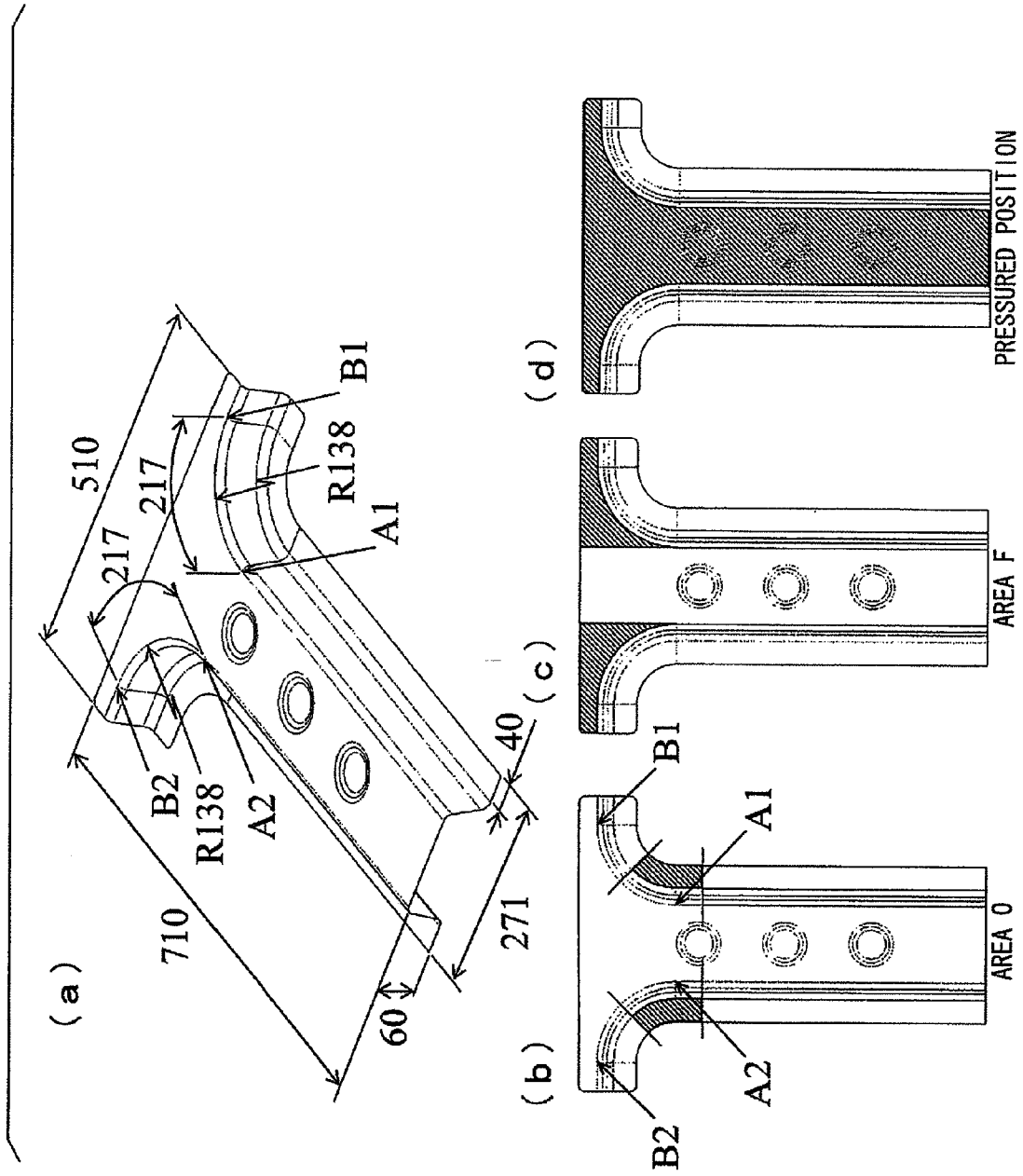

FIG. 29



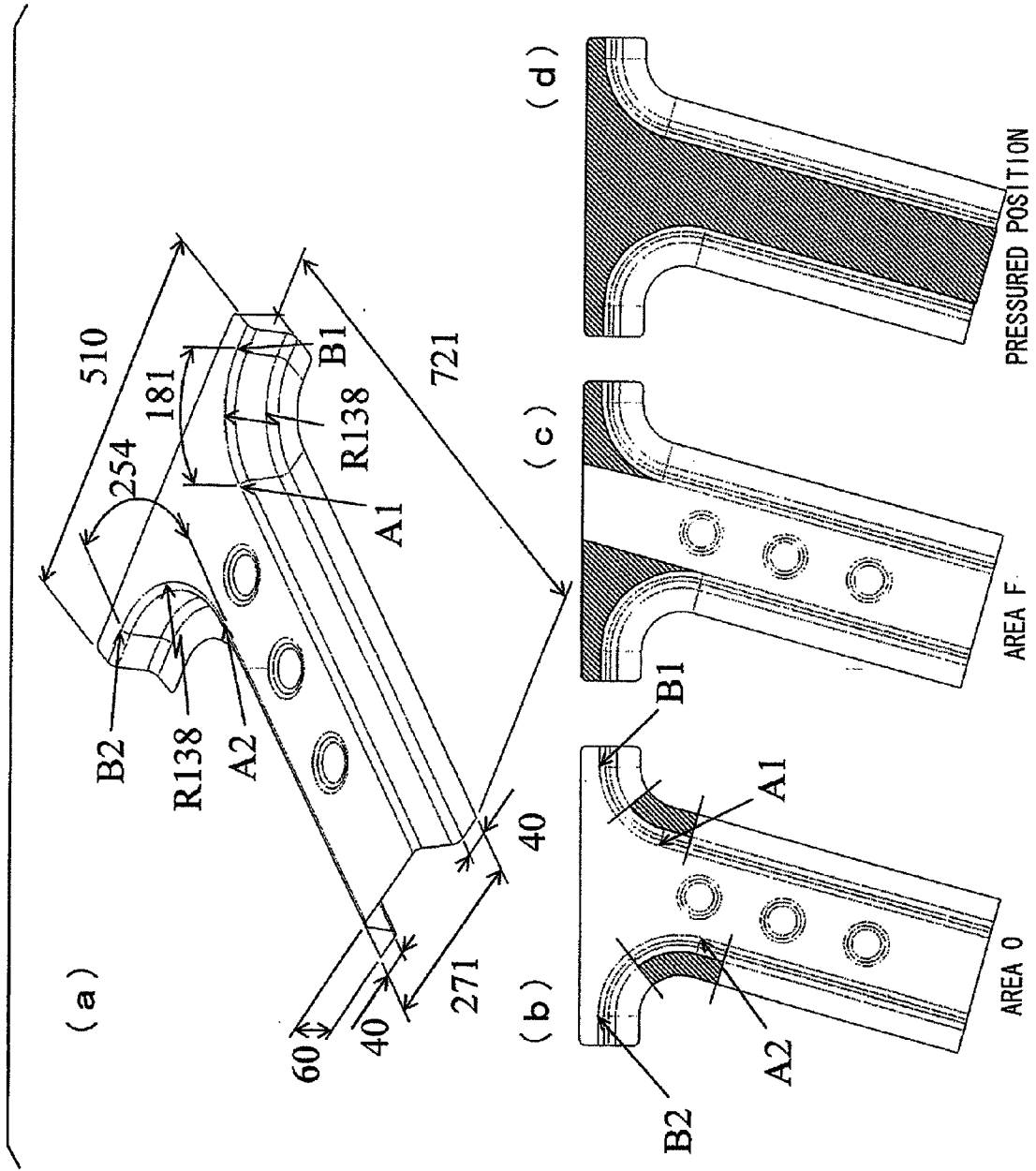

FIG. 31

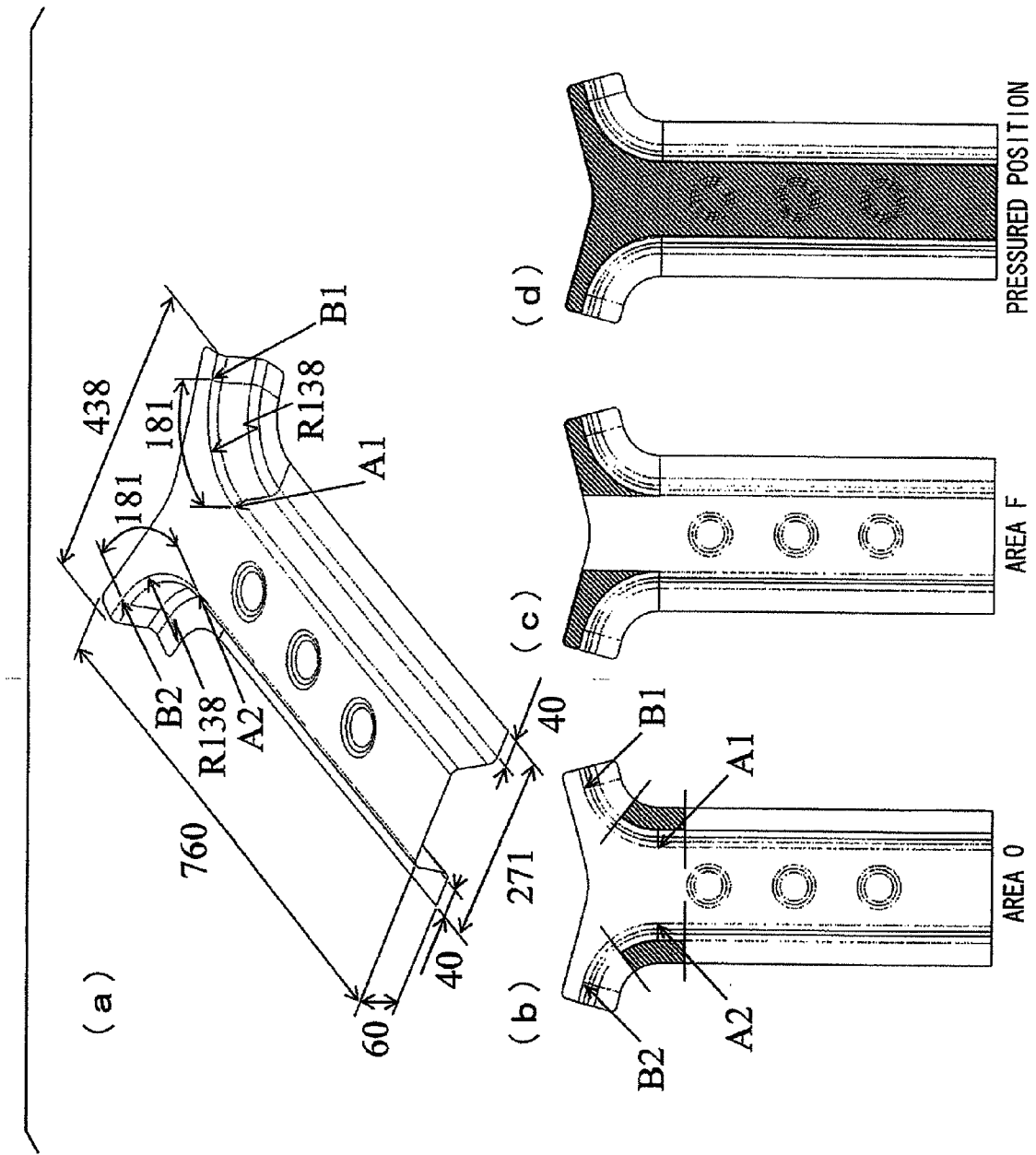

FIG. 32

PRE-PROCESSED SHAPE EXAMPLES 37 AND 38

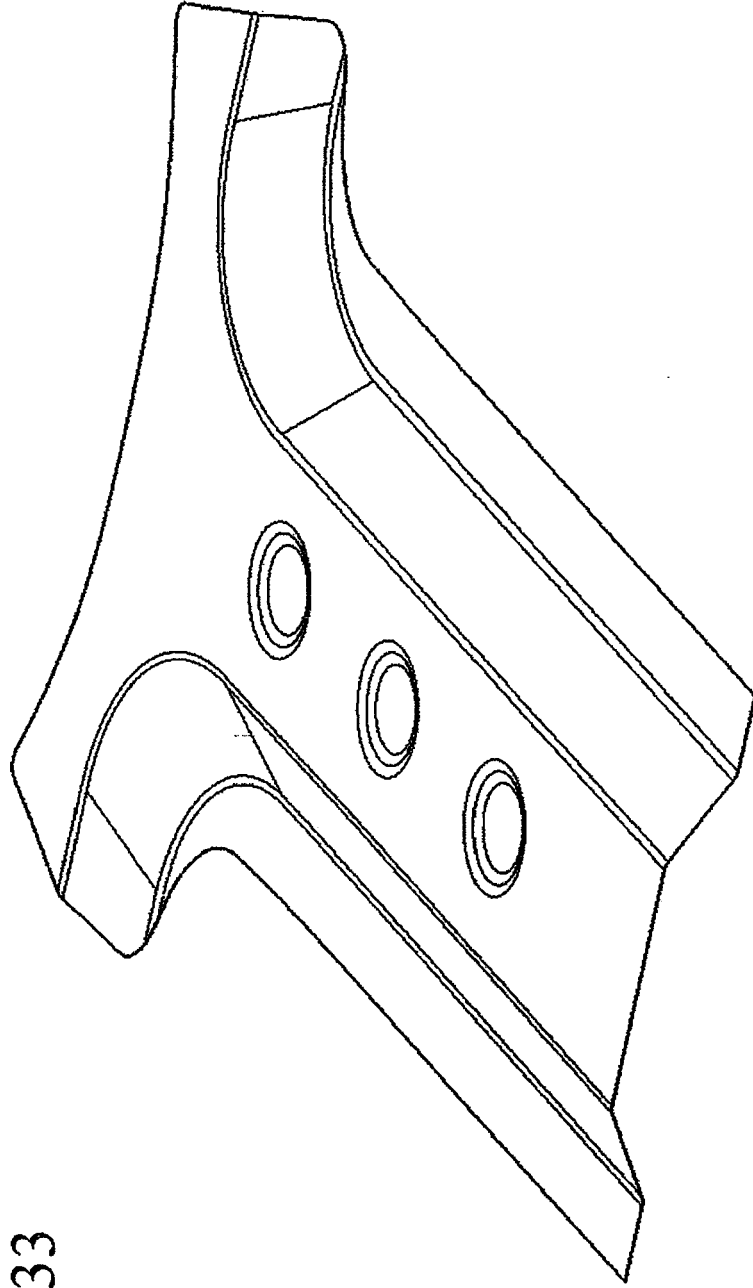

FIG. 33



EUROPEAN SEARCH REPORT

Application Number
EP 11 16 6738

DOCUMENTS CONSIDERED TO BE RELEVANT			
Category	Citation of document with indication, where appropriate, of relevant passages	Relevant to claim	CLASSIFICATION OF THE APPLICATION (IPC)
X	DE 103 18 056 A1 (BENTELER AUTOMOBILTECHNIK GMBH [DE]) 11 November 2004 (2004-11-11) * figures 1,4 * -----	1,2,5,6, 14	INV. B21D5/06 B21D22/02 B21D22/22 B21D53/88
			TECHNICAL FIELDS SEARCHED (IPC)
			B21D
The present search report has been drawn up for all claims			
Place of search		Date of completion of the search	Examiner
Munich		22 September 2011	Müller, Andreas
<p>CATEGORY OF CITED DOCUMENTS</p> <p>X : particularly relevant if taken alone Y : particularly relevant if combined with another document of the same category A : technological background O : non-written disclosure P : intermediate document</p> <p>T : theory or principle underlying the invention E : earlier patent document, but published on, or after the filing date D : document cited in the application L : document cited for other reasons & : member of the same patent family, corresponding document</p>			

1
EPO FORM 1503 03/82 (P04/C01)



EUROPEAN SEARCH REPORT

Application Number
EP 11 16 6738

DOCUMENTS CONSIDERED TO BE RELEVANT			
Category	Citation of document with indication, where appropriate, of relevant passages	Relevant to claim	CLASSIFICATION OF THE APPLICATION (IPC)
X	DE 103 18 056 A1 (BENTELER AUTOMOBILTECHNIK GMBH [DE]) 11 November 2004 (2004-11-11) * figures 1,4 * -----	1,2,5,6, 14	INV. B21D5/06 B21D22/02 B21D22/22 B21D53/88
			TECHNICAL FIELDS SEARCHED (IPC)
			B21D
The present search report has been drawn up for all claims			
Place of search Munich		Date of completion of the search 22 September 2011	Examiner Müller, Andreas
<p>CATEGORY OF CITED DOCUMENTS</p> <p>X : particularly relevant if taken alone Y : particularly relevant if combined with another document of the same category A : technological background O : non-written disclosure P : intermediate document</p> <p>T : theory or principle underlying the invention E : earlier patent document, but published on, or after the filing date D : document cited in the application L : document cited for other reasons & : member of the same patent family, corresponding document</p>			

1
EPO FORM 1503 03.82 (P04C01)

**ANNEX TO THE EUROPEAN SEARCH REPORT
ON EUROPEAN PATENT APPLICATION NO.**

EP 11 16 6738

This annex lists the patent family members relating to the patent documents cited in the above-mentioned European search report. The members are as contained in the European Patent Office EDP file on The European Patent Office is in no way liable for these particulars which are merely given for the purpose of information.

22-09-2011

Patent document cited in search report	Publication date	Patent family member(s)	Publication date
DE 10318056	A1	11-11-2004	NONE

EPO FORM P0459

For more details about this annex : see Official Journal of the European Patent Office, No. 12/82

REFERENCES CITED IN THE DESCRIPTION

This list of references cited by the applicant is for the reader's convenience only. It does not form part of the European patent document. Even though great care has been taken in compiling the references, errors or omissions cannot be excluded and the EPO disclaims all liability in this regard.

Patent documents cited in the description

- JP 2003103306 A [0005]
- JP 2004154859 A [0005]
- JP 2006015404 A [0005]
- JP 2008307557 A [0005]