



(11) **EP 2 527 283 A1**

(12) **EUROPEAN PATENT APPLICATION**

(43) Date of publication:
28.11.2012 Bulletin 2012/48

(51) Int Cl.:
B66B 21/00 (2006.01) B66B 23/00 (2006.01)

(21) Application number: **11380045.2**

(22) Date of filing: **25.05.2011**

(84) Designated Contracting States:
AL AT BE BG CH CY CZ DE DK EE ES FI FR GB GR HR HU IE IS IT LI LT LU LV MC MK MT NL NO PL PT RO RS SE SI SK SM TR
Designated Extension States:
BA ME

• **Fernandez Fidalgo, Juan Antonio**
CP: 33006 Oviedo
Asturias (ES)
• **Muniz Cambolor, Abdon**
33011 Oviedo
Asturias (ES)

(71) Applicant: **ThyssenKrupp Norte, S.A.**
33682 Mieres-Asturias (ES)

(74) Representative: **Carvajal y Urquijo, Isabel et al**
Clarke, Modet & Co.
c/ Goya, 11
28001 Madrid (ES)

(72) Inventors:
• **Casielles Estrada, Jose**
33012 Oviedo - Asturias (ES)

(54) **Support, module, transport system for displacement of people/goods and modernization method of people/goods transport systems**

(57) Support (1), module (101, 201) to be placed on the support, transport system for displacement of people/goods modernized with the module and modernization method of transport systems for displacement of people/goods. The support (1) has: fixings (11) to fix the support (1) to a bearing structure (10) of the transport system, horizontal tie plates (12) to support and horizontally place the module (101, 201), lateral tie plates (13) to support

and laterally place the module (101, 201), longitudinal tie plates (14) to support and longitudinally place the module (101, 201). The module has positioning and verification equipment (101A, 201A, 301A) to place the module (101, 201, 301) maintaining within tolerances the system lines of the transport system. The transport system has: a support (1) and an entrance (101)/exit (201)/central (301) module on an entrance (100)/exit (200) finished floor/in a central section.

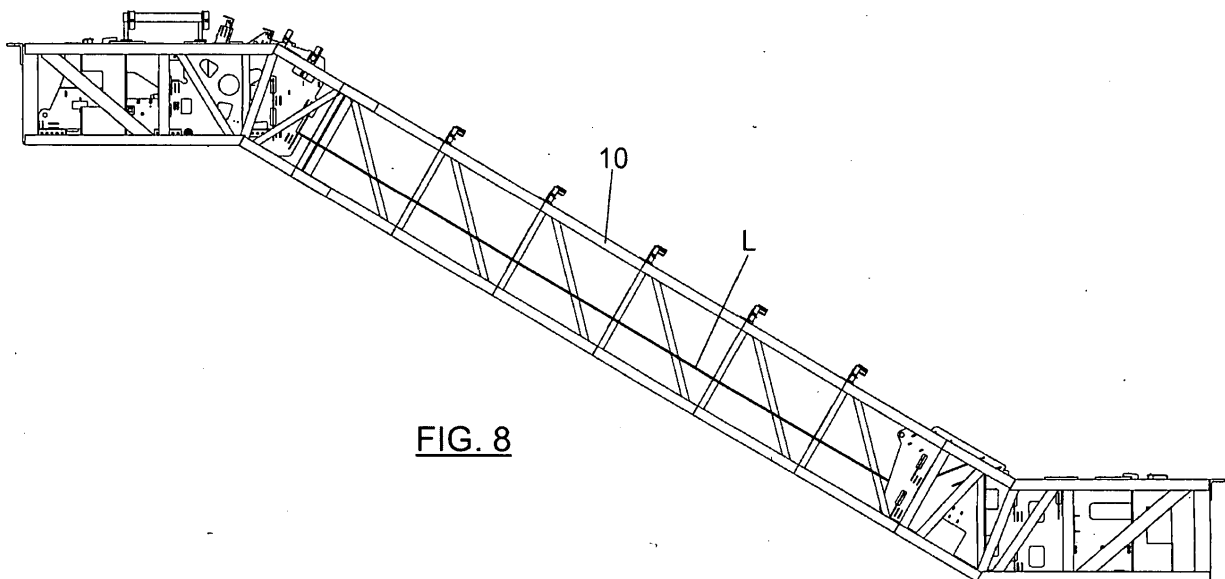

FIG. 8

EP 2 527 283 A1

Description-Field of the invention

[0001] The present invention refers to a support, to a module to be placed on the support, to a transport system for displacement of people/goods modernized with the module of the invention and to a modernization method of transport systems for displacement of people/goods, for example, escalators.

Background of the invention

[0002] US 6685002 discloses a method of modernizing an escalator using modular components. The mechanical and electrical parts of an existing escalator are removed, leaving only the structural truss framework and cross members as well as all external parts, such as external panels, that interface with the building. A single module is placed at the top of the escalator and another module at the bottom. A plurality of incline modules are placed in the central inclined part of the escalator, at each cross member. By utilizing these modules, the assembly of the escalator is simplified. Furthermore, an entirely new escalator system using the latest technology may be installed rather than merely installing new parts in an old system.

[0003] GB 2121748 discloses a reconstruction method for improving an obsolete escalator having a frame with supporting members projecting inwardly therefrom, mounting various constituents such as an endless series of moving steps, handrails moving in synchronism with the steps, a drive unit and drive sprockets, balustrades standing upright at both sides of the steps, and rails for guiding the steps comprising the steps of: removing the constituents from the frame of the obsolete escalator; removing the supporting members from the frame; mounting a second frame in the frame, the second frame being provided with supporting and base members already attached thereto for supporting the various constituents of a new escalator; mounting the balustrades, drive unit, rails and so forth, as well as series of steps, of the new man conveyor on the second frame; and covering the gaps between the second frame and the frame by outer deck members secured to the second frame.

Description of the invention

[0004] The invention refers to a support, to a module to be placed on the support and to a modernized transport system for displacement of people/goods such as those defined by the set of claims. The invention also refers to a modernization method of transport systems for displacement of people/goods, incorporating a module of the invention.

[0005] Depending on the positioning of the support and the module for the system modernized according to the invention to keep the working points of the system to be

modernized, the method can be fixed or adjustable.

[0006] The fixed method comprises:

- 1) Finding the working points of the system for the transport of people/goods or of the original escalator and transferring them to a physical point.
- 2) Dismounting all the components of the people/goods transport system or of the original escalator except for the structure.
- 3) Positioning the module supports on the structure with precision with respect to the working point.

3.1) To position the entrance and exit supports, jigs and fixtures or templates can be used.

3.2) On the other hand, to secure the perfect horizontality of the entrance and exit supports a level can be used.

3.3) Verify the positioning of the entrance supports with respect to the exit supports.

4) Placing the modules on the supports making the tie plates of the supports and the module plugs coincide. If the positioning of the supports has been correct, the working points of the machine coincide with those of the modules, thanks to the manufacturing precision of the modules which guarantees a tolerance between the anchoring plugs and the working point of the module. It is necessary to verify the correct positioning of the modules before continuing.

5) Establishing an alignment system between the entrance module, which can be a lower module, in the direction of the nose line. The auxiliary alignment system can be a thin rope or an emitter-retroreflective target alignment laser system. At this point it can be verified that this auxiliary line forms the desired degrees with the horizontal.

6) Positioning the necessary central modules along the central section or inclined section in the case of difference between the entrance and exit levels, as in an escalator. The central modules comprise an alignment measurement aperture or target configured to align the central module with the auxiliary line.

7) Completing the mounting of the transport system with the rest of the elements once the upper, lower and central modules are in their place. In the head modules, that is, in the upper and lower modules, most parts of the escalator are already preassembled at the factory, since it is where most mechanisms are concentrated. The central area, which can be completed on site until closing the circuit, entails simpler execution tasks.

[0007] In the adjustable method some stages are changed:

- 3') Positioning the bases or supports near the working point.
- 4') Placing the modules on the supports, in this ad-

justable method, there are adjustment means in all directions between support and the module. The adjustment means enable to make the working points of the modules coincide with those of the original system to be modernized. In order to attain the horizontality of the module a level can be used.

[0008] In both procedures it is attempted to respect the original cross members of the structure, that is, the transverse beams that join the sides of the structure. However, if at a certain point the transverse beams interfere with the new system, they are eliminated and replaced by other elements of at least the same mechanical resistance.

Brief description of the drawings

[0009] The following is a brief description of a series of drawings which will help understand the invention better relating to an embodiment of said invention which is presented as a non-limiting example thereof.

Figure 1 shows a lateral view of a system of the invention with the lines of the system.

Figure 2 shows a perspective view of the support for a head module of the invention.

Figure 3 shows a perspective view of an entrance module of the invention.

Figure 4 shows a perspective view of an exit module of the invention.

Figure 4A shows a module of the invention which has rolling means configured to roll on a rolling surface of the bearing structure.

Figure 5 shows a perspective view of a central module of the invention.

Figure 6 shows a detailed view of tie plates and plugs of the invention.

Figures 7, 7A show a detailed view of the adjustment means between a support of the invention and a module of the invention.

Figure 8 shows a lateral view of a system of the invention with the alignment lines.

Description of preferred embodiments of the invention

[0010] A first aspect of the invention refers to a support (1) for module (101, 201) of the transport system for displacement of people/goods comprising a plurality of plates where the transport system has system lines comprising:

1a) an entrance finished floor (100) defined by a level of entrance fixed plate (110);

1b) an exit finished floor (200) defined by a level of exit fixed plate (210);

1c) a nose line (300) defined by a nose (310) of the plates in a central section comprised between the entrance finished floor (100) and the exit finished floor (200), the plate nose is the most external of the plates when they are in the central section: if the system is an escalator, the nose of the step is the edge between the tread and the riser;

1d) an entrance working point (120), intersection of the nose line (300) and the entrance finished floor (100);

1e) an exit working point (220), intersection of the nose line (300) and the exit finished floor (200); where the support (1) comprises:

1f1) a plurality of fixings (11) configured to fix the support (1) to a bearing structure (10) of the transport system;

1f2) a plurality of horizontal tie plates (11) configured to support and horizontally place the module (101, 201);

1f3) a plurality of lateral tie plates (13) configured to support and laterally place the module (101, 201);

1f4) a plurality of longitudinal tie plates (14) configured to support and longitudinally place the module (101, 201);

[0011] According to other characteristics of the invention:

2a) The horizontal tie plates (12), the lateral tie plates (13) and the longitudinal tie plates (14) comprise adjustment means (121, 131, 141) to place the module (101, 201) maintaining within tolerances the system lines of the transport system.

3. The adjustment means (121, 131, 141) comprise:

3a) a horizontal threaded adjustment (121);

3b) a lateral threaded adjustment (131);

3c) a longitudinal threaded adjustment (141);

4. A second aspect of the invention refers to a module (101, 201, 301) for a transport system for displacement of people and/or goods comprising a plurality of plates where the transport system has system lines comprising:

4a) an entrance finished floor (100) defined by a level of entrance fixed plate (110);

4b) an exit finished floor (200) defined by a level of exit fixed plate (210);

4c) a nose line (300) defined by a nose (310) of the plates in a central section comprised be-

tween the entrance finished floor (100) and the exit finished floor (200);

4d) an entrance working point (120), intersection of the nose line (300) and the entrance finished floor (100);

4e) an exit working point (220), intersection of the nose line (300) and the exit finished floor (200);

4f) positioning and verification means (101A, 201A, 301A) configured to place the module (101, 201, 301) maintaining within tolerances the system lines of the transport system.

[0012] According to other characteristics of the invention:

5. The module (101, 201) comprises:

5a) a plurality of horizontal plugs (22) configured to be supported and horizontally located in horizontal tie plates (12) of a support (1) for the module (101, 201);

5b) a plurality of lateral plugs (23) configured to be supported and laterally located in lateral tie plates (13) of a support (1) for the module (101, 201);

5c) a plurality of longitudinal plugs (24) configured to be supported and longitudinally located in longitudinal tie plates (14) of a support (1) for the module (101, 201);

[0013] According to several embodiments of the invention, the tie plates (22, 23, 24) can be grouped in the same element, as shown in figure 4.

6. The module (101, 201) comprises:

6a) rolling means (25) configured to roll on a rolling surface of the bearing structure (10) for the module (101, 201).

These rolling means facilitate the placement of the module (101, 201) in the support (1). The weight of the module (101, 201) is usually high, since it contains numerous components, so any help which facilitates the placement of the module (101, 201) in the support (1) contributes to a reduction of the mounting time.

7. The entrance positioning and verification means (101A) are configured to maintain within tolerances the entrance working point (120) forming an entrance module (101).

8. The exit positioning and verification means (201A) are configured to maintain within tolerances the exit working point (220) forming an exit module (201).

9. The central positioning and verification means

(301A) are configured to maintain within tolerances the nose line (300) forming a central module (301). The central positioning and verification means (301A) configured to align the central module (301) with the alignment line L comprise an element selected between an alignment measurement aperture and a target.

10. A third aspect of the invention refers to a transport system for people/goods comprising:

10a) a support (1) according to any of the claims 1-3 and an entrance module (101) according to any of the claims 4, 5, 6 on an entrance finished floor (100);

10b) a support (1) according to any of the claims 1-3 and an exit module (201) according to any of the claims 4, 5, 7 on an exit finished floor (200);

10c) a support (1) according to any of the claims 1-3, and a central module (301) according to any of the claims 4, 8 in a central section.

[0014] According to other characteristics of the invention:

11. The system is an escalator comprising a plurality of steps where:

11a) the entrance finished floor (100) is a lower finished floor defined by a level of lower fixed plate (110);

11b) the exit finished floor (200) is an upper finished floor defined by a level of upper fixed plate (210);

11c) the nose line (300) is defined by the nose (310) of the escalator steps in a central section;

11d) a lower working point (120) intersection of the nose line (300) and the lower finished floor (100);

11e) an upper working point (220) intersection of the nose line (300) and the upper finished floor (200).

12. A fourth aspect of the invention refers to a modernization method of transport systems for displacement of people and/or goods comprising a plurality of plates where the transport system has system lines comprising:

12a) an entrance finished floor (100) defined by a level of entrance fixed plate (110);

12b) an exit finished floor (200) defined by a level of exit fixed plate (210);

12c) a nose line (300) is defined by a nose (310) of the plates in a central section comprised between the entrance finished floor (100) and the exit finished floor (200);

12d) an entrance working point (120) intersec-

tion of the nose line (300) and the entrance finished floor (100);

12e) an exit working point (220) intersection of the nose line (300) and the exit finished floor (200);

where the method comprises:

12f) locating the working points (120, 220) of the transport system, which can be an escalator to be modernized;

12g) transferring the working points (120, 220) to an end point at the transport system;

12h) dismantling components of the transport system; which can be an escalator to be modernized, except for a bearing structure (10);

12i) placing supports (1) of the module (101, 201, 301) on the bearing structure (10);

12j) placing the modules (101, 201, 301) on the supports (1);

12k) establishing an alignment system between the entrance module (101), which can be an upper module and an exit module (201), which can be a lower module, in a direction parallel to the nose line to obtain an alignment line L, the alignment system can be a thin rope or a target-emitter laser system, at this point it can be verified that this alignment line L forms the desired degrees with the horizontal;

12l) positioning the necessary central modules (301) along the central section or inclined section in the case of difference between the entrance and exit levels, as in an escalator.

[0015] According to other characteristics of the invention:

13. The method comprises:

13a) placing supports (1) of the module (101, 201) on the bearing structure (10) with precision with respect to the working points (120, 220); to attain the precision required it can be necessary to use jigs and fixtures or templates; to secure the perfect horizontality of the supports it is necessary to use a level.

13b) placing the modules (101, 201) on the supports (1) making the tie plates (12, 13, 14) and the plugs (22, 23, 24) coincide so that the working points of the modules (101, 201) coincide with the working points of the transport system, securing the correct positioning of the supports (1), the working points of the transport system coincide with those of the modules (101, 201) thanks to the manufacturing precision of the modules (101, 201) which guarantees a tolerance between the anchoring plugs (22, 23, 24) and the working point of the module (101, 201), it is necessary to verify the correct positioning of the modules (101, 201) before continuing with

the method.

14. The method comprises:

14a) placing supports (1) of the module (101, 201) on the bearing structure (10) approximately with respect to the working points (120, 220);

14b) placing the modules (101, 201) on the supports (1) adjusting a position of the modules (101, 201) on the supports (1) so that the working points of the modules (101, 201) coincide with the working points of the transport system; in this case an element selected between the support (1) and the module (101, 201) has adjustment elements in all directions. The adjustment means enable to make the working points of the modules coincide with those of the original system; in order to attain the horizontality of the modules (101, 201), a level can be used.

15. The method comprises:

15a) fixing the central modules (301) to the bearing structure (10) without fixing the central modules (301) to transverse elements to the movement direction of the transport system of the bearing structure (10).

16. The modernization method also comprises:

16a) completing a mounting of the transport system, mounting complementary elements after having installed the entrance module (101), the exit module (201) and the central module (301). In the head modules, entrance module (101) and exit module (201), most parts of the escalator are already pre-assembled at the factory, since it is where most mechanisms are concentrated. The central area is completed on site until closing the circuit but it is a simpler process.

Claims

1. A support (1) for module (101, 201) of a transport system for displacement of people and/or goods comprising a plurality of plates where the transport system has system lines comprising:

1a) an entrance finished floor (100) defined by a level of entrance fixed plate (110);

1b) an exit finished floor (200) defined by a level of exit fixed plate (210);

1c) a nose line (300) defined by a nose (310) of the plates in a central section comprised between the entrance finished floor (100) and the exit finished floor (200);

1d) an entrance working point (120), intersection

of the nose line (300) and the entrance finished floor (100);
 1e) an exit working point (220), intersection of the nose line (300) and the exit finished floor (200);

characterized in that the support (1) comprises:

1f1) a plurality of fixings (11) configured to fix the support (1) to a bearing structure (10) of the transport system;

1f2) a plurality of horizontal tie plates (11) configured to support and horizontally place the module (101, 201);

1f3) a plurality of lateral tie plates (13) configured to support and laterally place the module (101, 201);

1f4) a plurality of longitudinal tie plates (14) configured to support and longitudinally place the module (101, 201).

2. The support (1) of claim 1 **wherein**:

2a) the horizontal tie plates (12), the lateral tie plates (13) and the longitudinal tie plates (14) comprise adjustment means (121, 131, 141) to place the module (101, 201) maintaining within tolerances the system lines of the transport system.

3. The support for the module (101, 201) of claim 2 **wherein** the adjustment means (121, 131, 141) comprise:

3a) a horizontal threaded adjustment (121);

3b) a lateral threaded adjustment (131);

3c) a longitudinal threaded adjustment (141).

4. A module (101, 201, 301) for a transport system for displacement of people and/or goods comprising a plurality of plates where the transport system has system lines comprising:

4a) an entrance finished floor (100) defined by a level of entrance fixed plate (110);

4b) an exit finished floor (200) defined by a level of exit fixed plate (210);

4c) a nose line (300) defined by a nose (310) of the plates in a central section comprised between the entrance finished floor (100) and the exit finished floor (200);

4d) an entrance working point (120), intersection of the nose line (300) and the entrance finished floor (100);

4e) an exit working point (220), intersection of the nose line (300) and the exit finished floor (200);

characterized in that the module (101, 201,

301) comprises:

4f) positioning and verification means (101A, 201A, 301A) configured to place the module (101, 201, 301) maintaining within tolerances the system lines of the transport system.

5. The module (101; 201) of claim 4 **comprising**:

5a) a plurality of horizontal plugs (22) configured to be supported and horizontally located in horizontal tie plates (12) of a support (1) for the module (101, 201);

5b) a plurality of lateral plugs (23) configured to be supported and laterally located in lateral tie plates (13) of a support (1) for the module (101, 201);

5c) a plurality of longitudinal plugs (24) configured to be supported and longitudinally located in longitudinal tie plates (14) of a support (1) for the module (101, 201).

6. The module (101, 201) of claim 5 **comprising**:

6a) rolling means (25) configured to roll on a rolling surface of the bearing structure (10) for the module (101, 201).

7. The module of claim 5-6 **wherein** the entrance positioning and verification means (101A) are configured to maintain within tolerances the entrance working point (120) forming an entrance module (101).

8. The module of claim 5-6 **wherein** the exit positioning and verification means (201A) are configured to maintain within tolerances the exit working point (220) forming an exit module (201).

9. The module of claim 4 **wherein** the central positioning and verification means (301A) are configured to maintain within tolerances the nose line (300) forming a central module (301).

10. A transport system for people/goods **comprising**:

10a) a support (1) according to any of the claims 1-3 and an entrance module (101) according to any of the claims 4-7 on an entrance finished floor (100);

10b) a support (1) according to any of the claims 1-3 and an exit module (201) according to any of the claims 4-6, 8 on an exit finished floor (200);

10c) a support (1) according to any of the claims 1-3 and a central module (301) according to any of the claims 4, 9 in a central section.

11. The system of claim 10 wherein the system is an escalator comprising a plurality of steps **wherein**:

11a) the entrance finished floor (100) is a lower finished floor defined by a level of lower fixed plate (110);

11b) the exit finished floor (200) is an upper finished floor defined by a level of upper fixed plate (210);

11c) the nose line (300) is defined by the nose (310) of the escalator steps in a central section;

11d) a lower working point (120) intersection of the nose line (300) and the lower finished floor (100);

11e) an upper working point (220) intersection of the nose line (300) and the upper finished floor (200).

12. A modernization method of transport systems for displacement of people and/or goods comprising a plurality of plates where the transport system has system lines comprising:

12a) an entrance finished floor (100) defined by a level of entrance fixed plate (110);

12b) an exit finished floor (200) defined by a level of exit fixed plate (210);

12c) a nose line (300) defined by a nose (310) of the plates in a central section comprised between the entrance finished floor (100) and the exit finished floor (200);

12d) an entrance working point (120) intersection of the nose line (300) and the entrance finished floor (100);

12e) an exit working point (220) intersection of the nose line (300) and the exit finished floor (200);

characterized in that the method comprises:

12f) locating the working points (120, 220) of the transport system;

12g) transferring the working points (120, 220) to an end point at the transport system;

12h) dismounting components of the transport system, except for a bearing structure (10);

12i) placing supports (1) according to any of the claims 1-3 of the module (101, 201, 301) according to any of the claims 4-9 on the bearing structure (10);

12j) placing the modules (101, 201, 301) on the supports (1);

12k) establishing an alignment system between an entrance module (101) and an exit module (201) in a direction parallel to the nose line to obtain an alignment line L;

12l) positioning central modules (301) along the central section.

13. The method of claim 12 **comprising:**

13a) placing supports (1) of the module (101, 201) on the bearing structure (10) with precision

with respect to the working points (120, 220);
13b) placing the modules (101, 201) on the supports (1) making the tie plates (12, 13, 14) and the plugs (22, 23, 24) coincide so that the working points of the modules (101, 201) coincide with the working points of the transport system.

14. The method of claim 12 **comprising:**

14a) placing supports (1) of the module (101, 201) on the bearing structure (10) approximately with respect to the working points (120, 220);

14b) placing the modules (101, 201) on the supports (1) adjusting a position of the modules (101, 201) on the supports (1) so that the working points of the modules (101, 201) coincide with the working points of the transport system.

15. The modernization method of any of the claims 12-14 further **comprising:**

15a) fixing the central modules (301) to the bearing structure (10) without fixing the central modules (301) to transverse elements of the bearing structure (10).

16. The modernization method of any of the claims 12-15 further **comprising:**

16a) completing a mounting of the transport system mounting complementary elements after having installed the entrance module (101), the exit module (201) and the central module (301).

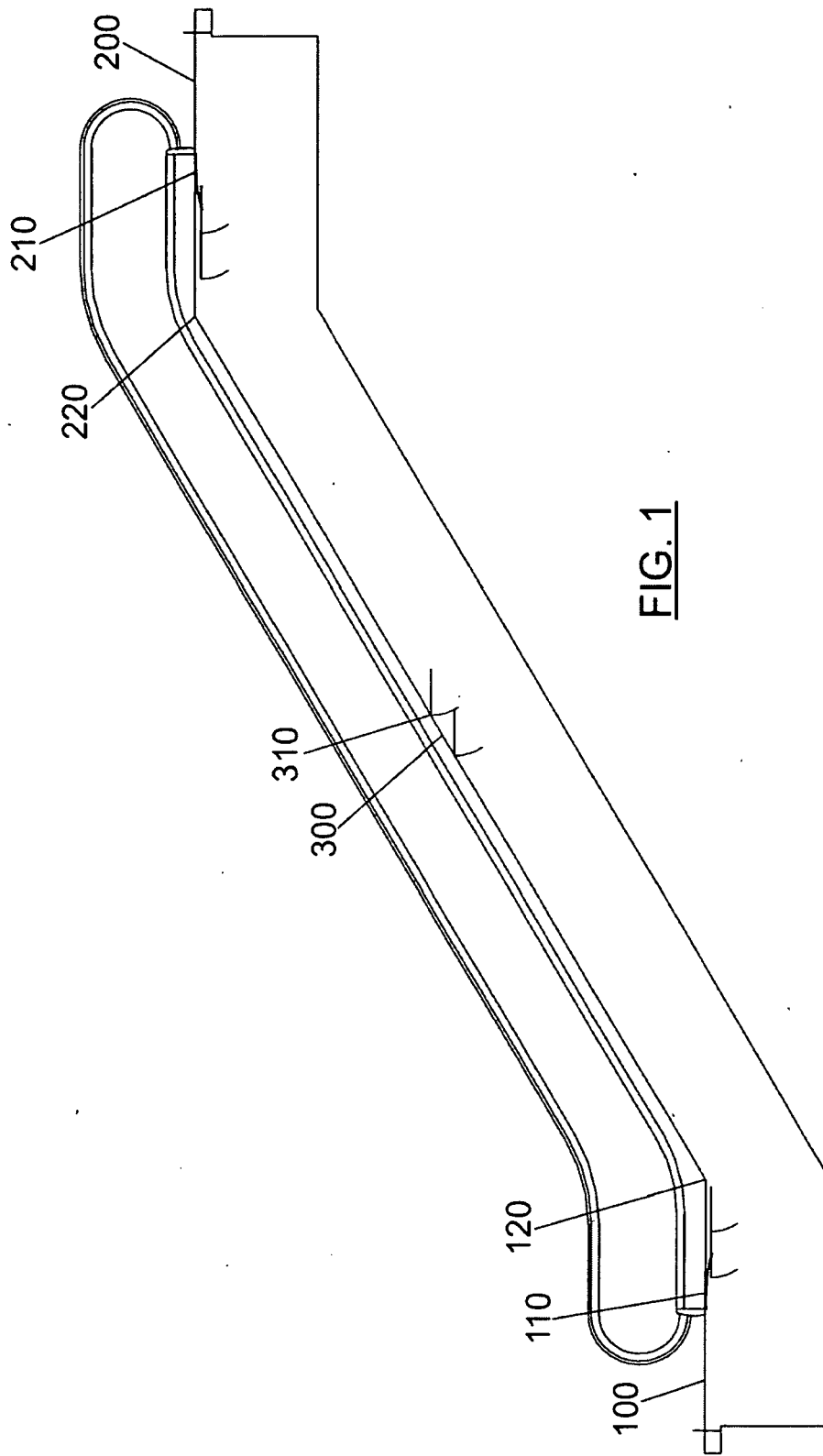

FIG. 1

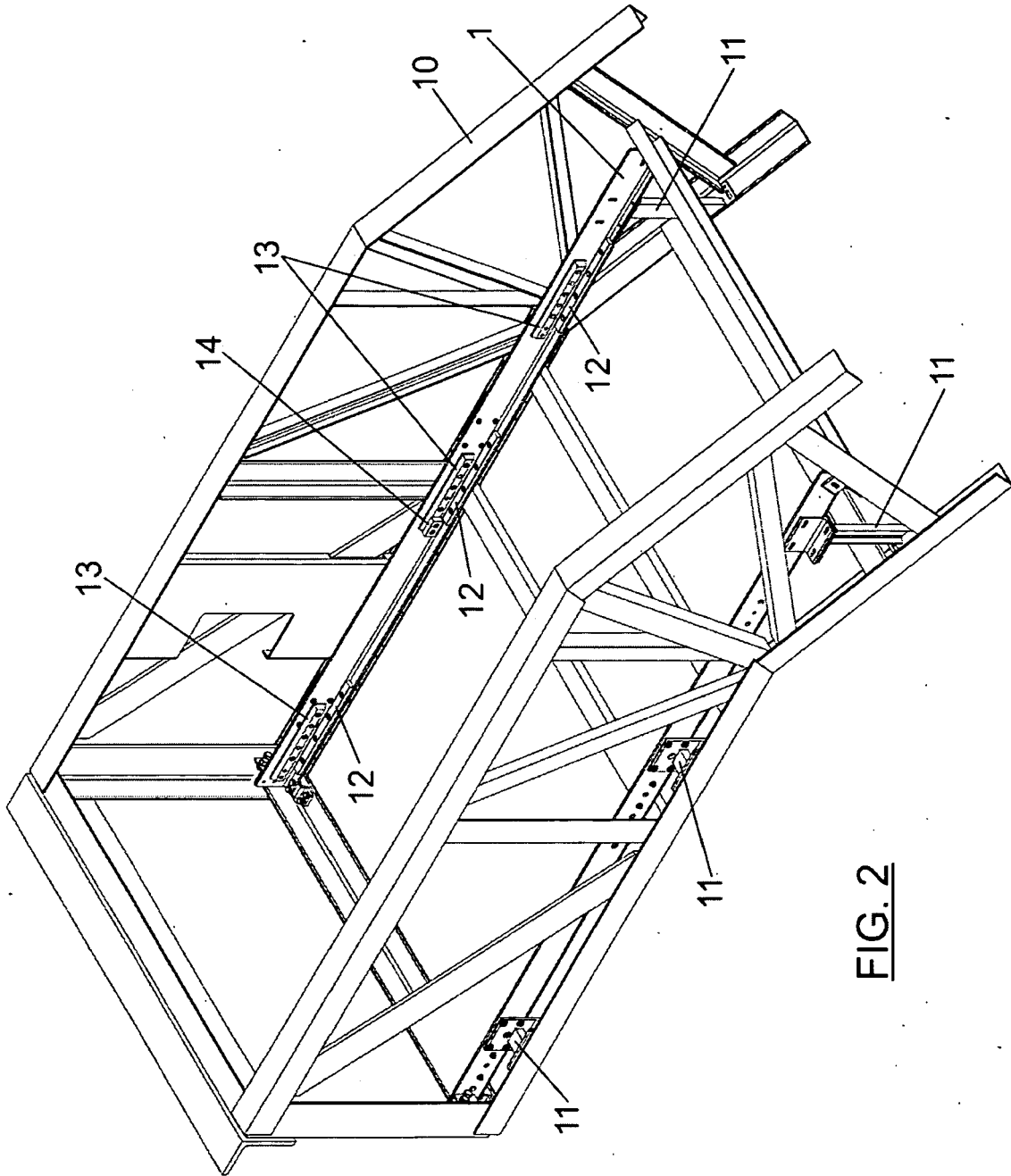

FIG. 2

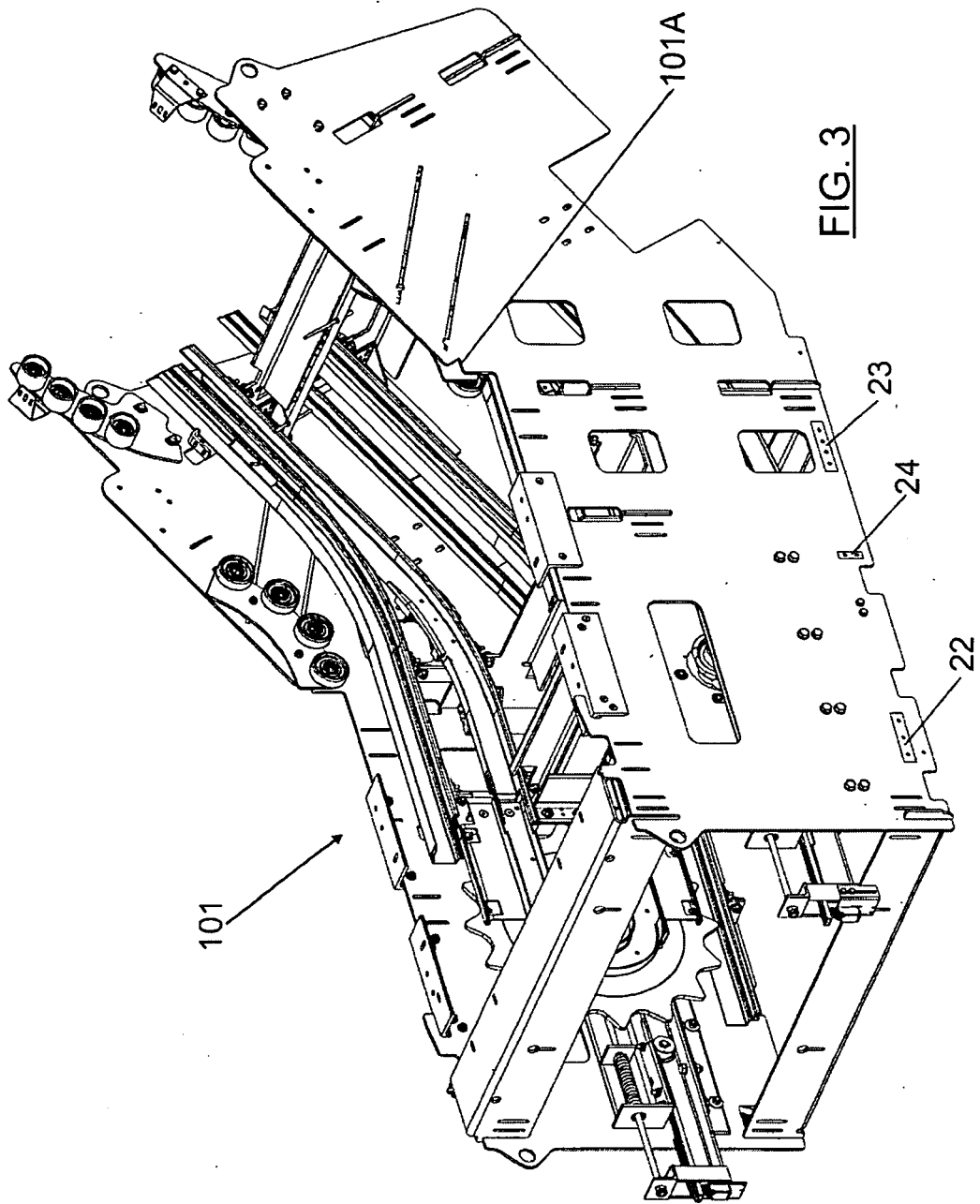

FIG. 3

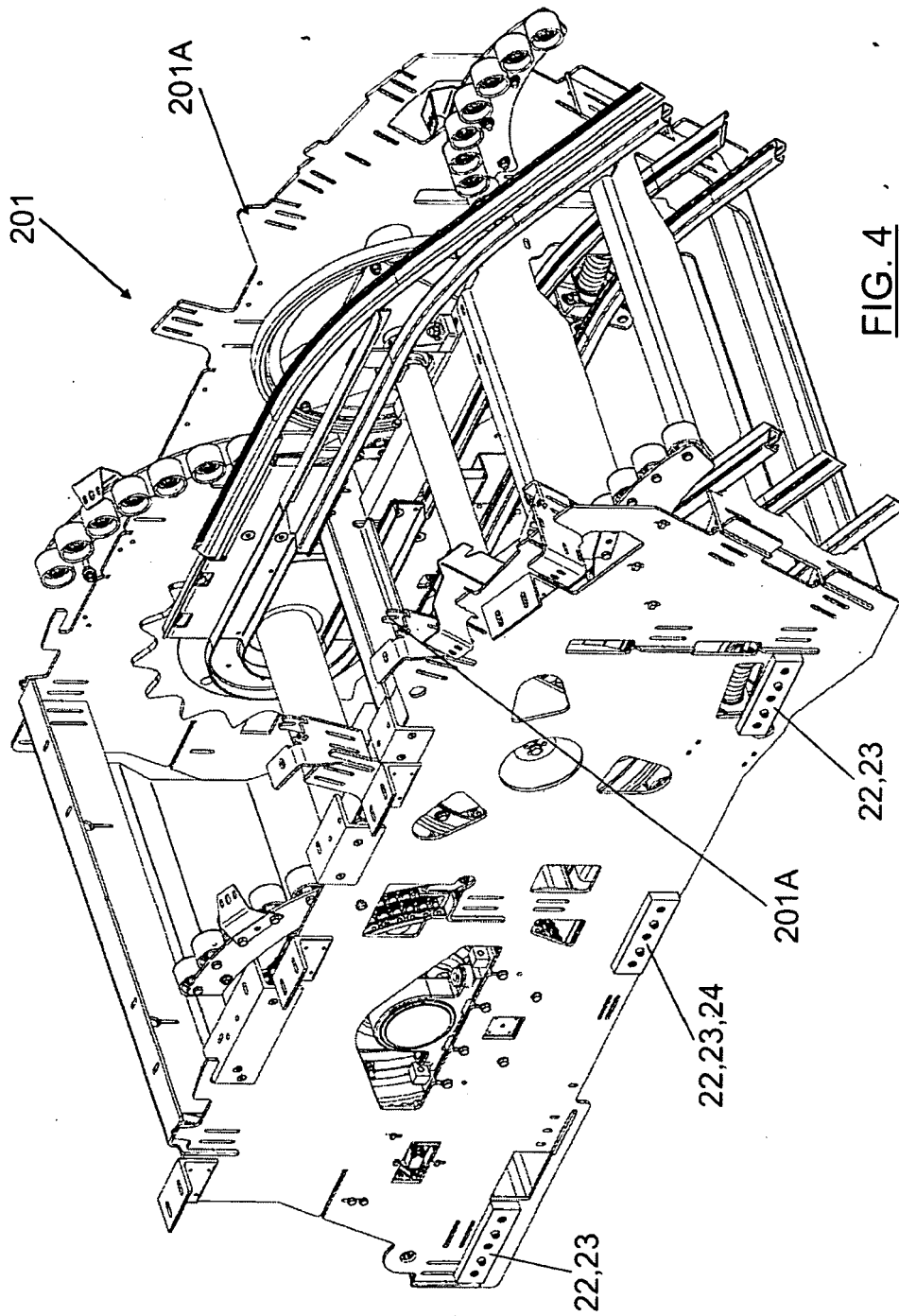

FIG. 4

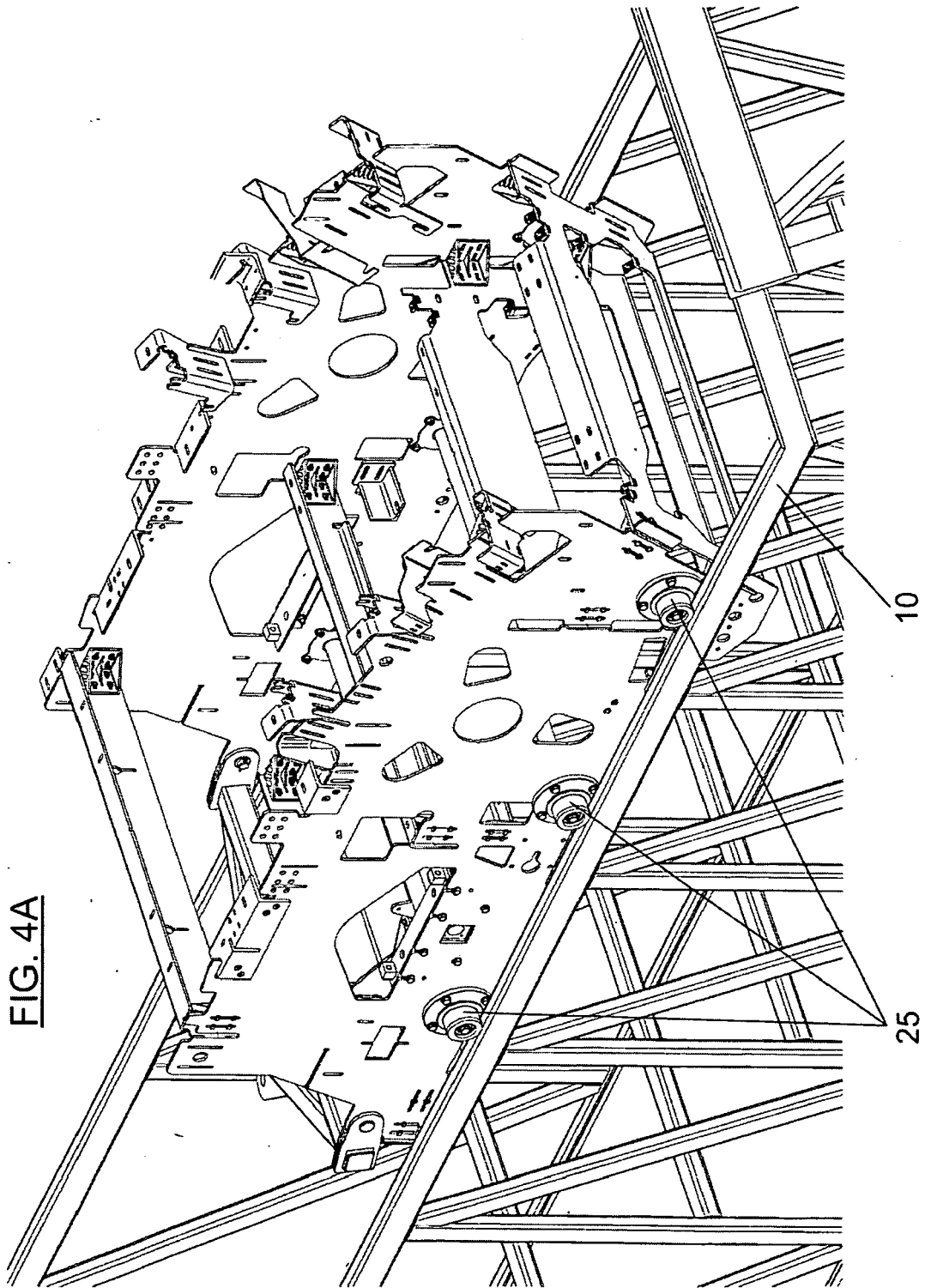
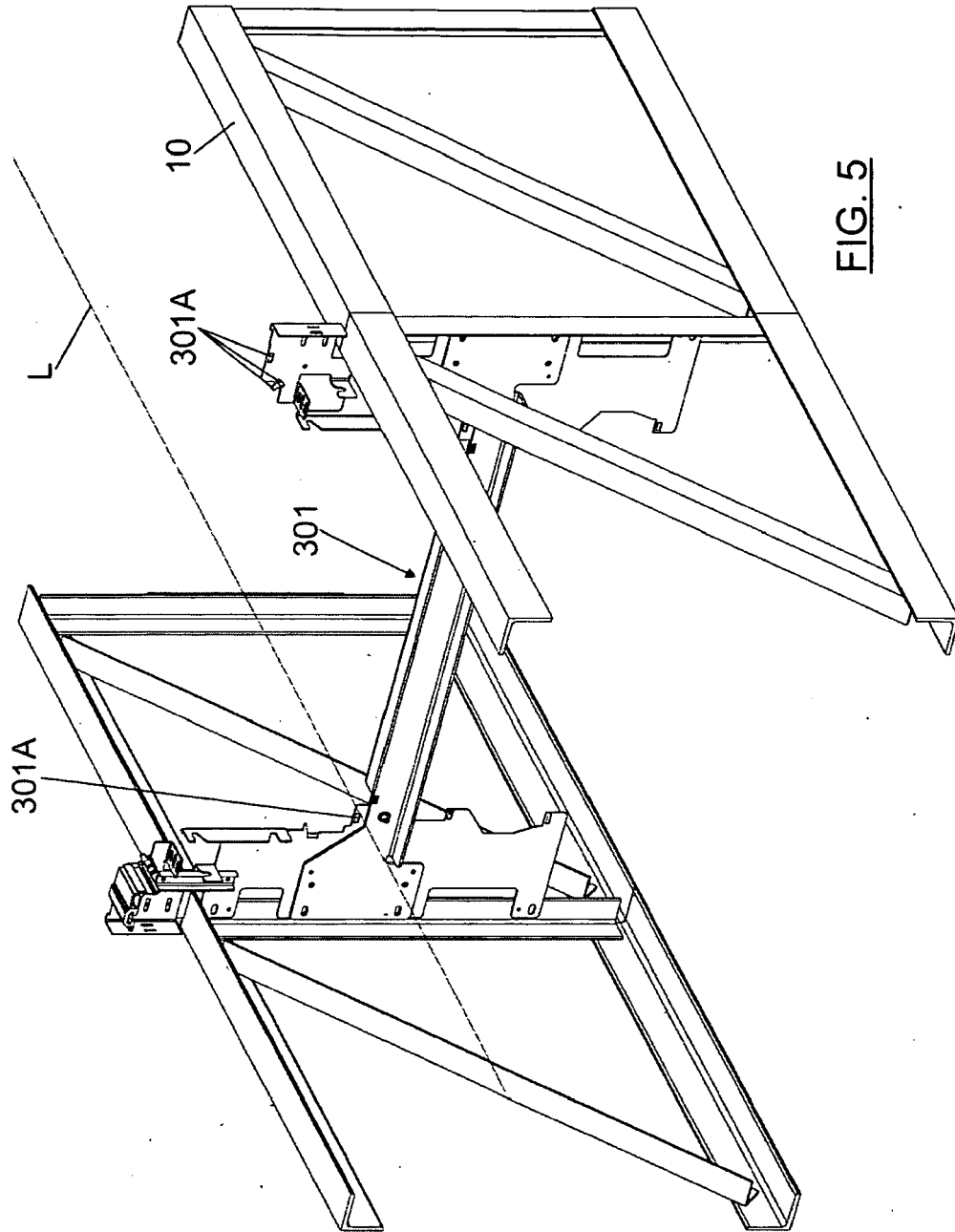
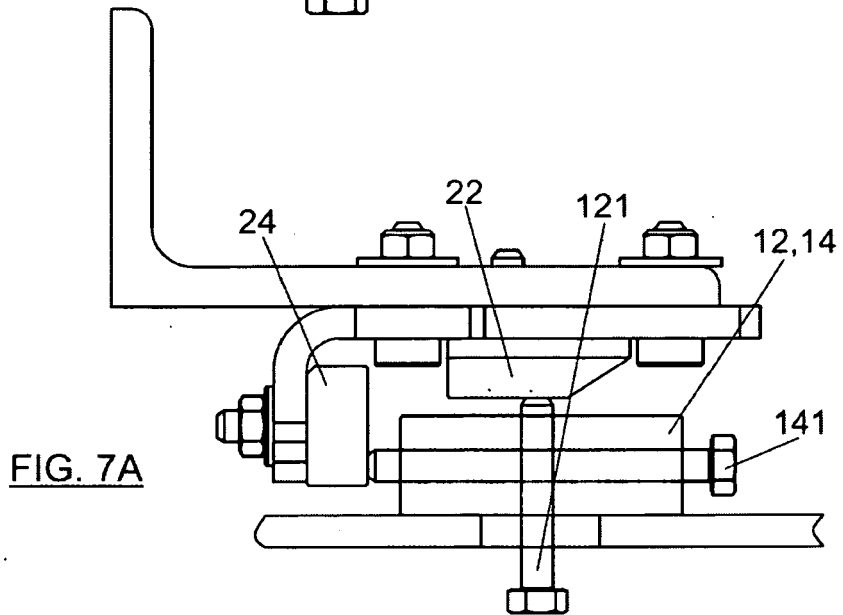
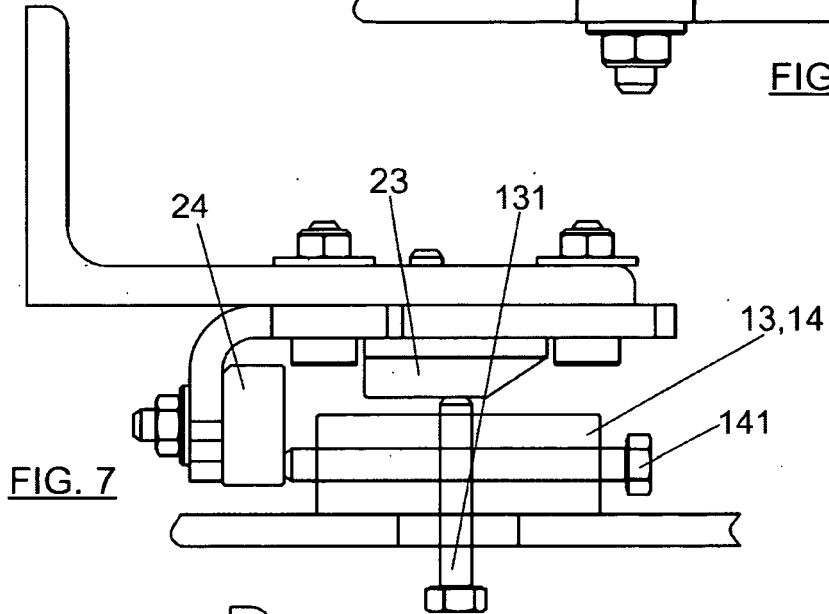
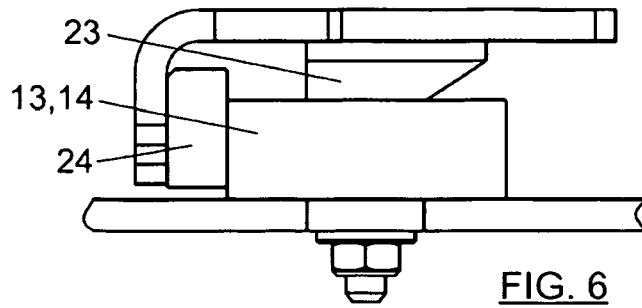

FIG. 4A





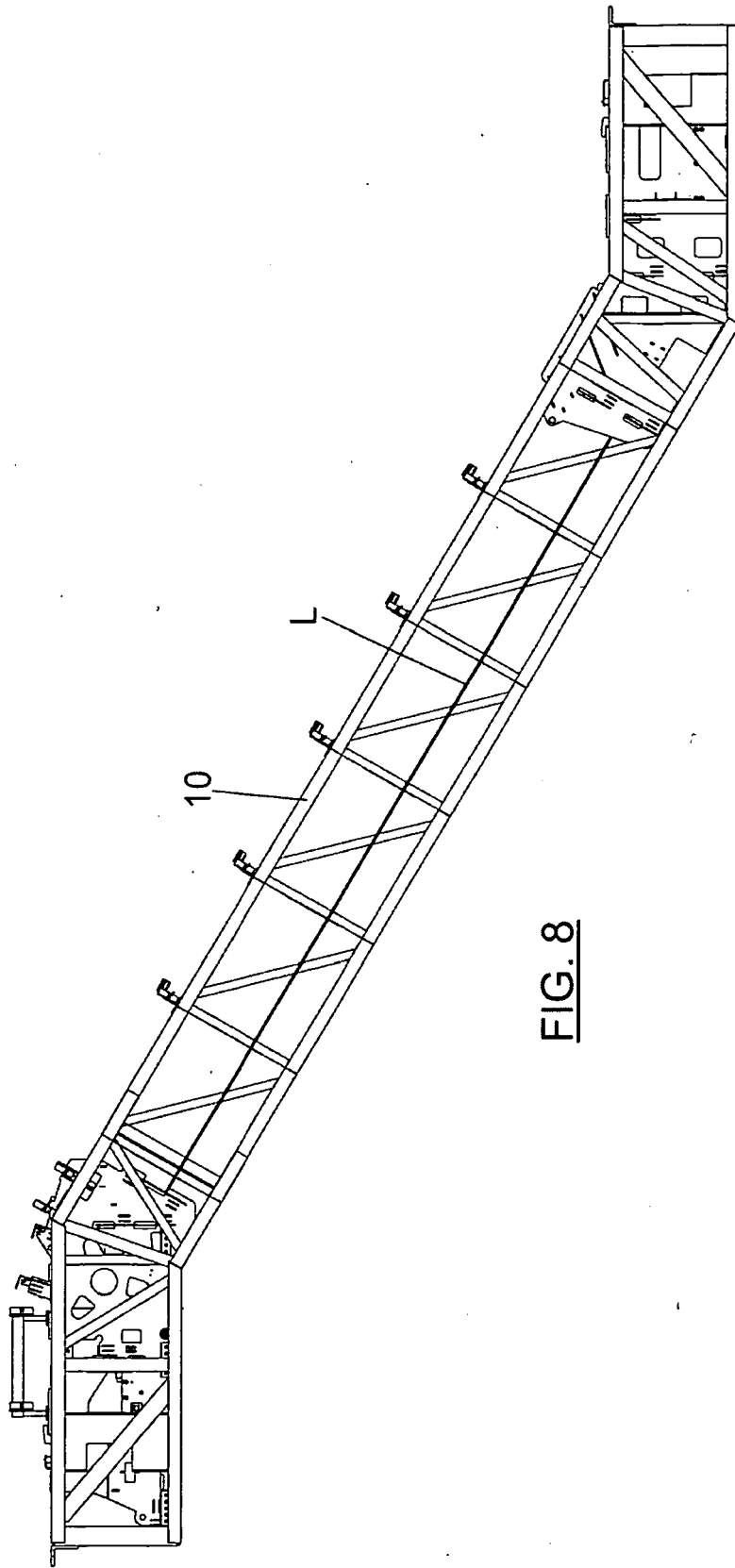

FIG. 8



EUROPEAN SEARCH REPORT

Application Number
EP 11 38 0045

DOCUMENTS CONSIDERED TO BE RELEVANT			
Category	Citation of document with indication, where appropriate, of relevant passages	Relevant to claim	CLASSIFICATION OF THE APPLICATION (IPC)
X	CN 101 723 232 A (XIZI OTIS ELEVATOR CO LTD) 9 June 2010 (2010-06-09) * the whole document *	1-3	INV. B66B21/00 B66B23/00
E	& WO 2011/079256 A2 (OTIS ELEVATOR CO [US]; WU DE [CN]; JIANG MINGPING [CN]; LI JIANGUO [CN]) 30 June 2011 (2011-06-30) * paragraphs [0021] - [0025]; figures 1, 6, 11 * -----	1-3	
			TECHNICAL FIELDS SEARCHED (IPC)
			B66B
The present search report has been drawn up for all claims			
Place of search The Hague		Date of completion of the search 21 October 2011	Examiner Iuliano, Emanuela
CATEGORY OF CITED DOCUMENTS X : particularly relevant if taken alone Y : particularly relevant if combined with another document of the same category A : technological background O : non-written disclosure P : intermediate document		T : theory or principle underlying the invention E : earlier patent document, but published on, or after the filing date D : document cited in the application L : document cited for other reasons & : member of the same patent family, corresponding document	

1
EPO FORM 1503 03.02 (P04C01)



Application Number

EP 11 38 0045

CLAIMS INCURRING FEES

The present European patent application comprised at the time of filing claims for which payment was due.

- Only part of the claims have been paid within the prescribed time limit. The present European search report has been drawn up for those claims for which no payment was due and for those claims for which claims fees have been paid, namely claim(s):
- No claims fees have been paid within the prescribed time limit. The present European search report has been drawn up for those claims for which no payment was due.

LACK OF UNITY OF INVENTION

The Search Division considers that the present European patent application does not comply with the requirements of unity of invention and relates to several inventions or groups of inventions, namely:

see sheet B

- All further search fees have been paid within the fixed time limit. The present European search report has been drawn up for all claims.
- As all searchable claims could be searched without effort justifying an additional fee, the Search Division did not invite payment of any additional fee.
- Only part of the further search fees have been paid within the fixed time limit. The present European search report has been drawn up for those parts of the European patent application which relate to the inventions in respect of which search fees have been paid, namely claims:
- None of the further search fees have been paid within the fixed time limit. The present European search report has been drawn up for those parts of the European patent application which relate to the invention first mentioned in the claims, namely claims:
1-3
- The present supplementary European search report has been drawn up for those parts of the European patent application which relate to the invention first mentioned in the claims (Rule 164 (1) EPC).



**LACK OF UNITY OF INVENTION
SHEET B**

Application Number
EP 11 38 0045

The Search Division considers that the present European patent application does not comply with the requirements of unity of invention and relates to several inventions or groups of inventions, namely:

1. claims: 1-3

a plurality of fixing for attaching securely a support of a transport system structure.

2. claims: 4-9

positioning and verification means configured to place a module of a transport system

3. claims: 10, 11

structural modularity of a transport system

4. claims: 12-16

method for locating and transferring the working points of a transport system

**ANNEX TO THE EUROPEAN SEARCH REPORT
ON EUROPEAN PATENT APPLICATION NO.**

EP 11 38 0045

This annex lists the patent family members relating to the patent documents cited in the above-mentioned European search report. The members are as contained in the European Patent Office EDP file on The European Patent Office is in no way liable for these particulars which are merely given for the purpose of information.

21-10-2011

Patent document cited in search report	Publication date	Patent family member(s)	Publication date
CN 101723232 A	09-06-2010	CN 101723232 A	09-06-2010
		WO 2011079256 A2	30-06-2011

EPO FORM P0459

For more details about this annex : see Official Journal of the European Patent Office, No. 12/82

REFERENCES CITED IN THE DESCRIPTION

This list of references cited by the applicant is for the reader's convenience only. It does not form part of the European patent document. Even though great care has been taken in compiling the references, errors or omissions cannot be excluded and the EPO disclaims all liability in this regard.

Patent documents cited in the description

- US 6685002 B [0002]
- GB 2121748 A [0003]