



(11) **EP 2 540 929 B1**

(12) **EUROPEAN PATENT SPECIFICATION**

(45) Date of publication and mention of the grant of the patent:
10.08.2016 Bulletin 2016/32

(51) Int Cl.:
E04F 10/10 (2006.01) **E06B 9/92 (2006.01)**
E06B 9/06 (2006.01)

(21) Application number: **12174268.8**

(22) Date of filing: **29.06.2012**

(54) **Folding shutter**

Klappladen

Volet pliant

(84) Designated Contracting States:
AL AT BE BG CH CY CZ DE DK EE ES FI FR GB GR HR HU IE IS IT LI LT LU LV MC MK MT NL NO PL PT RO RS SE SI SK SM TR

(30) Priority: **29.06.2011 BE 201100401**

(43) Date of publication of application:
02.01.2013 Bulletin 2013/01

(73) Proprietors:
• **Renson Sunprotection Projects nv**
8790 Waregem (BE)
• **Renson, Paul**
9771 Nokere (BE)

(72) Inventors:
• **Perquy, Patrick Marc**
9031 Drogen (BE)
• **Devetter, Davy**
9080 Lochristi (BE)

(74) Representative: **Hostens, Veerle et al**
KOB NV
Patents
President Kennedypark 31 C
8500 Kortrijk (BE)

(56) References cited:
US-A- 1 581 832 **US-A- 5 343 923**
US-A1- 2010 282 418

EP 2 540 929 B1

Note: Within nine months of the publication of the mention of the grant of the European patent in the European Patent Bulletin, any person may give notice to the European Patent Office of opposition to that patent, in accordance with the Implementing Regulations. Notice of opposition shall not be deemed to have been filed until the opposition fee has been paid. (Art. 99(1) European Patent Convention).

Description

[0001] The present invention relates to a folding shutter, comprising:

- a part which is immovable in the fitted position;
- a basic shutter part which is attachable to the immovable part and is rotatable with respect to said immovable part about a fixed rotation shaft;
- one or more shutter extension parts which is/are rotatable with respect to the immovable part about a displaceable rotation shaft, in which all said shutter parts are pivotably connected to one another in a concertina-like manner and in which the folding shutter is displaceable between a closed position, in which said shutter parts extend virtually in line with one another, and an open position, in which said shutter parts extend at an angle with respect to one another or parallel to one another as a result of a displacement of the displaceable rotation shaft;
- drive means which engage with one of said shutter extension parts for driving the movement of the displaceable rotation shaft; and
- locking means, comprising first locking means which are attached to the immovable part and second locking means which are attached to one of said shutter parts, in which the locking means engage with each other in order to lock the folding shutter in the closed position when the folding shutter is moved to the closed position.

[0002] Such folding shutters are already known in great variety. They are used, for example, as a sunshutter or as protection against rain or to close off an opening, for example by way of protection against burglary, etc. The shutter parts of such folding shutters can be constructed in many different ways and may, for example, be configured as solid, hollow or perforated panels, or as having slats which are arranged virtually parallel to one another, etc. Usually, such folding shutters comprise two shutter parts (a basic shutter part and one shutter extension part). Sometimes, these folding shutters may also comprise more than two shutter parts which are connected to one another in a concertina-like manner.

[0003] A large number of possible drive means for moving the shutter parts between the fully open position and the closed position of the folding shutter are also already known. The movement may in this case be driven by hand or by a motor. In this connection, drive means are known which make use of a pulling cable or chain drive or belt drive, etc.

[0004] These shutter parts usually comprise locks which have to be operated manually. The known locking means which ensure automatic locking of the folding shutter when this folding shutter is moved into its closed position have various drawbacks.

[0005] The known electric locks have the drawback that if the electricity fails either the folding shutter cannot

be locked or the folding shutter remains locked in its closed position and can no longer be opened.

[0006] The known mechanical locking means are usually of complicated construction and/or do not work very reliably. US 2010/0282418 A1 discloses a folding shutter according to the introduction of the first claim. In this case, various locking means for such a folding shutter are described. However, these locking means in each case comprise pivoting components. In this case, if these pivoting components become soiled or oxidized, there is a significant risk that these components will be in the wrong position at the wrong point in time, in which case the folding shutter no longer opens or closes correctly. In addition, the construction of these locking means is in each case relatively complicated and comprises a relatively large number of movable components.

[0007] It is therefore an object of the invention to provide such a folding shutter which can be locked in its closed position in a more reliable manner and the locking means of which are of a relatively simple construction.

[0008] This object is achieved by providing a folding shutter, comprising

- a part which is immovable in the fitted position;
- a basic shutter part which is attachable to the immovable part and is rotatable with respect to said immovable part about a fixed rotation shaft;
- one or more shutter extension parts which is/are rotatable with respect to the immovable part about a displaceable rotation shaft, in which all said shutter parts are pivotably connected to one another in a concertina-like manner and in which the folding shutter is displaceable between a closed position, in which said shutter parts extend virtually in line with one another, and an open position, in which said shutter parts extend at an angle with respect to one another or parallel to one another as a result of a displacement of the displaceable rotation shaft;
- drive means which engage with one of said shutter extension parts for driving the movement of the displaceable rotation shaft;
- locking means, comprising first locking means which are attached to the immovable part and second locking means which are attached to one of said shutter parts, in which the locking means engage with each other in order to lock the folding shutter in the closed position when the folding shutter is moved to the closed position; and
- an actuator rod which is attached to the last-mentioned shutter extension part virtually at right angles to the displaceable rotation shaft, is arranged as to be movable in a bar of this shutter extension part, between a starting position and an end position, said bar being designed as a guide profile, in which the actuator rod can be moved in a guided manner;

in which said drive means are connected to said actuator rod in order to drive the movement of the actuator rod,

the movement of the actuator rod being driven asynchronously with respect to the movement of the shutter extension part with which the drive means engage and in which the second locking means are attached to said actuator rod in order to attach said second locking means to the respective partial shutter, in such a manner that when the folding shutter is moved to the closed position, the locking means engage with each other at the end of this displacement, when the actuator rod is moved from its starting position to its end position.

[0009] By using such a displaceable actuator rod, it is possible to provide a simple locking action which can be achieved in a smooth manner, without pivoting parts of the locking means.

[0010] It is possible to provide the locking means of a folding shutter according to the present invention on one side of the folding shutter or centrally on the folding shutter, between the two lateral sides thereof. It is also possible to provide more locking means and to provide locking means, for example on both lateral sides of the folding shutter, in order to achieve a particularly strong lock.

[0011] In a specific embodiment of a folding shutter according to the present invention with simple locking means, the first locking means comprise a locking hook and the second locking means comprise a locking pin which engages in the locking hook when the folding shutter is moved to the closed position.

[0012] Still more specifically, the locking hook may in this case comprise a hook-shaped slot having an entry opening and a locking opening, in which the locking pin, when it engages in the locking hook, is taken from the entry opening to the locking opening via the hook-shaped slot and in which the entry opening is designed to be wider than the diameter of the locking pin and the dimensions of the locking opening virtually correspond to the diameter of the locking pin.

[0013] In a preferred embodiment of a folding shutter according to the present invention, the folding shutter comprises counteracting means which exert a counterforce on the actuator rod, counter to the force with which the drive means engage on the actuator rod when moving the folding shutter into its closed position, so that the locking means engage with each other on account of this counterforce when the folding shutter is moved into its closed position.

[0014] Still more preferably, the counteracting means of such an embodiment comprise a spring, in which the spring force of said spring forms part of the counterforce.

[0015] With such a spring, it is possible to exert a reliable and long-lasting secure counterforce on the actuator rod in a simple manner.

[0016] In a particular embodiment of a folding shutter according to the present invention comprising said counteracting means, the actuator rod forms part of the counteracting means, in which case the force of gravity on said actuator rod forms part of the counterforce. The actuator rod will in each case form part of a folding shutter according to the invention, in which the shutter extension

part undergoes an up and down movement in order to open and close the folding shutter. Said rotation shafts of such a particular embodiment preferably extend virtually horizontally in the fitted position of the folding shutter.

5 In the closed position of such a folding shutter, the basic shutter part and the shutter extension part are then preferably virtually in line with one another, one below the other. In the open position of such a folding shutter, the shutter parts then preferably form a kind of awning with respect to the immovable part.

10 **[0017]** With such a folding shutter in which the shutter parts can be moved (if the folding shutter is fitted to a wall) from a kind of awning to form a screen which extends virtually parallel to the wall, it is possible to ensure that the folding shutter will not break loose on account of, for example, a wind gust solely using the force of gravity as counterforce. Only by using the force of gravity as counterforce can the locking means then keep the folding shutter in its closed position. However, it is preferred nevertheless to provide additional counteracting means which exert an additional counterforce on the actuator rod in addition to the force of gravity. In this way, the actuator rod can be made lighter, as a result of which it will also be more smoothly displaceable with respect to the shutter extension part. The total counterforce is preferably chosen as a compromise between a counterforce which is sufficiently large to be able to keep the folding shutter in its closed position in a secure way and a counterforce which is sufficiently small to be able to release the locking means in a simple manner in order to be able to easily open the folding shutter.

20 **[0018]** The drive means of a folding shutter according to the present invention may, more specifically, comprise a pulling cable and a disc, in which one end of the pulling cable is connected to the actuator rod and the other end is connected to the disc and said pulling cable can be rolled onto said disc. In such an embodiment, the disc is preferably arranged in the vicinity of the fixed rotation shaft.

25 **[0019]** Such drive means with a pulling cable are particularly suitable for folding shutters which can be moved between a kind of awning and a screen which extends virtually parallel to the wall (when the folding shutter is attached to a wall). When the folding shutter is opened, the pulling cable is then rolled onto the disc. When the folding shutter is closed, the shutter extension part can be lowered under the effect of the force of gravity, with the pulling cable exerting a smaller counteracting force and thus guiding the movement. If the folding shutter has virtually vertical rotation shafts, then the drive means preferably comprise a closed continuous cable or chain or belt, etc. so that the same pulling means can be used both for opening and for closing the folding shutter since, in this case, the force of gravity can no longer be used for opening the folding shutter.

30 **[0020]** In an alternative particular embodiment according to the present invention, the drive means comprise a toothed belt, in which the actuator rod is connected to

the toothed belt in order to connect the latter to the drive means. By means of such a toothed belt, it is possible to control the positioning of the actuator rod more accurately at each moment.

[0021] If the drive means are fixedly connected to the actuator rod, then the drive means of a folding shutter according to the present invention can engage with the shutter extension part either by means of this actuator rod, or in a particular embodiment, for example, by means of an entrainment element and an entrainment pin. With such a particular embodiment, the shutter extension part is connected to the actuator rod by means of such an entrainment element and such an entrainment pin, with the entrainment element being fixedly connected to the shutter extension part and being provided with an entrainment slot in which the entrainment pin is received and with the entrainment pin being fixedly connected to the actuator rod.

[0022] The second locking means and the drive means of a folding shutter according to the present invention are preferably connected to said actuator rod virtually at the location of the two opposite ends of the actuator rod.

[0023] The drive means are preferably connected to the actuator rod in the vicinity of the displaceable rotation shaft.

[0024] The shutter extension part to which the actuator rod is connected, is preferably pivotably attached to the basic shutter part, so that the basic shutter part and said shutter extension part are rotatable with respect to one another about a hinging rotation shaft. The second locking means are in this case connected to the actuator rod, preferably in the vicinity of the hinging rotation shaft.

[0025] In this way, the folding shutter is centrally locked between the fixed rotation shaft and the displaceable rotation shaft. On the one hand, centrally locking the folding shutter in its closed position has the advantage that flapping of the folding shutter on account of, for example, the wind can be reduced significantly. On the other hand, centrally locking the folding shutter has the advantage that a large distance is available for the locking means to engage with each other, as a result of which a secure locking can be achieved in a smooth manner.

[0026] A folding shutter according to the present invention furthermore preferably comprises guide means for guiding the displacement of the displaceable rotation shaft. Such guide means preferably comprise a guide profile which forms part of the immovable part.

[0027] The shutter extension part furthermore preferably comprises a guide profile, in which the actuator rod is fitted in a guided manner.

[0028] The drive means preferably comprises a motor for driving the movement of the displaceable rotation shaft.

[0029] The present invention will now be explained in more detail by means of the following detailed description of some preferred embodiments of folding shutters according to the present invention. The aim of this description is solely to give illustrative examples and to indicate

further advantages and features of these folding shutters and can therefore not be interpreted as a limitation of the area of application of the invention or of the patent rights defined in the claims.

[0030] In this detailed description, reference numerals are used to refer to the attached drawings, in which:

- **Fig. 1** shows a perspective view of a folding shutter according to the present invention in its closed position, viewed from the front left-hand side;
- **Fig. 2** shows a perspective view of the folding shutter from Fig. 1 in a position between its closed position and its open position, viewed from the front left-hand side;
- **Fig. 3** shows a view of the folding shutter from Fig. 1 in its completely open position, viewed from the front left-hand side;
- **Fig. 4** shows a perspective view of a part of a folding shutter according to the present invention at the location of the locking means and in a position close to its closed position, viewed from the front right-hand side;
- **Fig. 5** shows a perspective view of the part of the folding shutter from Fig. 4 in its completely open position, viewed from the front left-hand side;
- **Fig. 6** shows a perspective view of the part of the folding shutter from Fig. 4 in a position close to its closed position, viewed from the rear left-hand side;
- **Fig. 7** shows the circled part of the folding shutter from Fig. 6 in more detail;
- **Fig. 8** shows a left-hand side view of a folding shutter according to the present invention in its closed position;
- **Fig. 9** shows a left-hand side view of the folding shutter from Fig. 8 in a position just before the closed position;
- **Fig. 10** shows a left-hand side view of the folding shutter from Fig. 8 in its completely open position;
- **Fig. 11** shows a perspective view of a shutter extension part of a folding shutter according to the present invention at the location of the locking means in the closed position, viewed from the rear side;
- **Fig. 12** shows a perspective view of the part of the folding shutter from Fig. 11 in a position close to its closed position, viewed from the rear side;
- **Fig. 13** shows a side view of the part of the folding shutter from Fig. 11 with an associated part of the attachment profile of the folding shutter in the closed position;
- **Fig. 14** shows a side view of the part of the folding shutter from Fig. 13 in a position close to its closed position;
- **Fig. 15** shows a cross section of the part of the folding shutter from Fig. 13 along section AA', as indicated in Fig. 13;
- **Fig. 16** shows a perspective view of the part of the folding shutter from Fig. 11 in more detail in the closed position, viewed from the rear side;

- **Fig. 17** shows a perspective view of the part of the folding shutter from Fig. 11 in more detail in a position close to its closed position, viewed from the rear side.

[0031] The illustrated folding shutters (1) according to the present invention in each case comprise attachment profiles (2, 20) by means of which these are attachable to a wall. These attachment profiles (2, 20) form part of a part of the folding shutter (1) which is immovable after the folding shutter (1) has been installed.

[0032] Each folding shutter (1) comprises a basic shutter part (3) and a shutter extension part (4).

[0033] The basic shutter part (3) is connected on either side to the attachment profiles (2, 20) by means of securing pins (13) so as to be rotatable with respect to a fixed rotation shaft (A). The fixed rotation shaft (A) has been indicated in Figs. 2 and 3 and the securing pins (13) can be seen in the embodiments illustrated in Figs. 4, 6 and 8-10.

[0034] The shutter extension part (4) is connected on either side to guide pieces (17) by means of securing pins (15, 27) so as to be rotatable with respect to a displaceable rotation shaft (C). The displaceable rotation shaft has been indicated in Figs. 2 and 3 and the guide pieces (17) with the securing pins (15, 27) can be seen in Figs. 4, 6, 8-10 and 11-17. These guide pieces (17) are fitted in a guided manner in respective slots in the respective attachment profiles (2, 20) which are configured as guide profiles (2, 20).

[0035] The shutter extension part (4) is furthermore connected to the basic shutter part (3) by means of hinges (14) so as to be pivotable about a pivot pin (B). The pivot pin (B) has been indicated in Figs. 2 and 3 and the hinges (14) can be seen in Figs. 4-7 and 10.

[0036] The illustrated folding shutters (1) in each case comprise only two shutter parts (3, 4). A folding shutter (1) according to the invention may also comprise more than two shutter parts (3, 4), in which case further shutter extension parts (4) are in each case pivotably attached to the last shutter extension part (4), so that all shutter parts (3, 4) together can be moved in a concertina-like manner with respect to one another.

[0037] By moving the displaceable rotation shaft (C) and thus the hinges of the shutter extension part (4) with respect to the basic shutter part (3), the folding shutter (1) can be moved between a closed position, as illustrated in Figs. 1, 8, 11, 13, and 16 and a completely open position, as illustrated in Figs. 3, 5 and 10. In the closed position of the folding shutter (1), the shutter parts (3, 4) extend in line with one another, one below the other. In the completely open position of the folding shutter (1), the shutter parts (3, 4) extend virtually at right angles to the attachment profiles (2, 20) and form a kind of awning. As is illustrated in Figs. 2, 4, 6, 7, 9, 10, 12 and 17, the folding shutter (1) can also assume any position between its completely open and its closed position.

[0038] The rotation shafts (A, C) and the pivot pin (B) of the illustrated embodiments extend virtually horizon-

tally. It is also possible to produce a folding shutter (1) according to the invention in which these shafts (A, B, C) extend, for example, virtually vertically.

[0039] The shutter parts (3, 4) of the illustrated folding shutters (1) are in each case designed as slat grates. They comprise a few bars (5) to which slats (6) are attached virtually parallel to one another and at an intermediate distance apart. Such folding shutters (1) can be advantageously used as a sunshutter. The shutter parts (3, 4) of other folding shutters (1) according to the invention may, for example, also be configured as flat panels which may be solid or hollow, or as perforated panels, etc. The illustrated folding shutters (1) may be virtually completely made of aluminium. However, according to the principle of the invention, folding shutters (1) may also be made, for example, substantially from wood or plastic, etc.

[0040] In order to be able to move the shutter parts (3, 4) between the closed position of the folding shutter (1) and the completely open position of the folding shutter (1), the illustrated folding shutters (1) comprise a motor (19) which can be seen in Figs. 4 to 6.

[0041] In the embodiment as illustrated in Figs. 8-10, this motor (19) is used to drive a disc (8) which can be seen in Figs. 8 to 10 for rolling up and unrolling a pulling cable (7). The disc (8) is installed in the vicinity of the fixed rotation shaft (A). At one end, the pulling cable (7) is connected to an actuator rod (11) which is arranged so as to be movable in a bar (5) of the shutter extension part (4). To this end, said bar (5) of the shutter extension part (4) is designed as a guide profile, in which the actuator rod (11) can be moved in a guided manner. By rolling the pulling cable (7) onto the disc (8), the actuator rod (11), and therefore the shutter extension part (4) as well, are pulled towards the fixed rotation shaft (A), in which case the displaceable rotation shaft (C) moves towards the fixed rotation shaft (A). During the displacement, the bottom side of the shutter extension part (4) is guided in the guide profiles (2, 20) by means of the guide pieces (17). In this way, the folding shutter (1) is moved into its open position. By, on the other hand, unrolling the pulling cable (7) from the disc (8), the actuator rod (11), and therefore the shutter extension part (4) as well, are lowered, away from the fixed-rotation shaft (A), in which case the displaceable rotation shaft (C) moves away from the fixed rotation shaft (A). With this displacement, the bottom side of the shutter extension part (4) is also guided in the guide profiles (2, 20) by means of the guide pieces (17).

[0042] Instead of driving the movement of the disc (8) (and therefore also the movement of the pulling cable (7) and thus also the movement of the shutter extension part (4) by means of a motor (19), this movement could also be driven manually. Instead of using a pulling cable (7), it is also known to use, for example, a drive chain or a drive belt, etc. for moving the shutter extension part (4). Many alternative drive means can thus be used in order to arrive at a folding shutter (1) according to the present

invention.

[0043] In the embodiment as illustrated in Figs. 11-17, the motor (19) is, for example, used to drive a toothed belt (24). On one side, the toothed belt (24) is connected to the shutter extension part (4) by means of a guide piece (17), a securing pin (27) and an entrainment element (26) with entrainment slot (28). The guide piece (17) is fixedly connected to the toothed belt (24). The entrainment element (26) is fixedly connected to the shutter extension part (4). The securing pin (27) is fixedly connected to the guide piece (17) and displaceably fitted in the entrainment slot (28) in the entrainment element (26). By displacing the toothed belt (24), the securing pin (27) which is situated on the guide piece (17) and acts as an entrainment pin (27) entrains the entrainment element (26) and thus the shutter extension part (4). In this way, the shutter extension part (4) is also moved either towards the fixed rotation shaft (A), in which case the displaceable rotation shaft (C) moves towards the fixed rotation shaft (A), or away from the fixed rotation shaft (A), in which case the displaceable rotation shaft (C) is moved away from the fixed rotation shaft (A). During the displacement, the bottom side of the shutter extension part (4) is guided in the guide profiles (2, 20) by means of the guide pieces (17). In this way, the folding shutter (1) is moved into its open position or its closed position, respectively.

[0044] On the other side, the toothed belt (24) from the embodiment in Figs. 11-17 is connected to an actuator rod (11) by means of the same guide piece (17), the same securing pin (27) and a securing member (25). In this case, this actuator rod (11) is also attached in a bar (5) of the shutter extension part (4) so as to be movable and said bar (5) is to this end also configured as a guide profile, in which the actuator rod (11) is displaceable in a guided manner.

[0045] Thus, in both described embodiments, the movement of the actuator rod (11) is driven asynchronously with respect to the movement of the shutter extension part (4) by the same drive means (7, 8, 19, 24). Alternative drive means also have to be configured in such a manner in each case that they drive the movement of the folding shutter (1) asynchronously with respect to the movement of the actuator rod (11) which is driven by the same drive means (7, 8, 19, 24).

[0046] In the illustrated embodiments, said actuator rod (11) extends along a large part of the height of the bar (5) in which it is fitted. In the illustrated embodiments, the pulling cable (7) or the toothed belt (24), respectively, is attached virtually on the bottom side of said actuator rod (11) (by means of the guide piece (17) and an optional securing pin (27)), i.e. nearly at the location of the displaceable rotation shaft (C). On the other side of the actuator rod (11), i.e. nearly at the location of the pivot pin (B), a locking pin (10) is attached. On the corresponding guide profile (20), a locking hook (9) is attached which corresponds to said locking pin (10) and in which the locking pin (10) can engage when the folding shutter (1)

is being moved into the closed position in order to lock the folding shutter (1) in its closed position.

[0047] As can clearly be seen in Figs. 7, 16 and 17, the locking hook (9) of the illustrated folding shutters (1) is plate-shaped and comprises a hook-shaped slot (21) which is directed downwards from an entry opening (22) towards a locking opening (23). The entry opening (22) is wider than the diameter of the locking pin (10). In the embodiment in Fig. 7, the hook-shaped slot (21) gradually becomes narrower from the entry opening (22) up to the downwardly directed locking opening (23), while in the embodiment in Figs. 16 and 17, the width of the slot (21) remains the same between the entry opening (22) and the downwardly directed locking opening (23). In both embodiments, the dimensions of the locking opening (23) correspond substantially to the diameter of the locking pin (10).

[0048] In this way, when the locking pin (10) engages in the locking hook (9), the former can engage in the entry opening (22) in a simple manner and with a great degree of certainty, after which it is guided in the slot (21) towards the locking opening (23), in which the locking pin (10) is locked in the locking hook (9).

[0049] In the closed position of the folding shutter (1), the actuator rod (11) is in its end position at the bottom of the bar (5), as is illustrated in Figs. 8, 11, 13 and 16.

[0050] If the folding shutter (1) is then opened, the pulling cable (7) or the toothed belt (24) will move the bottom side of the actuator rod (11) upwards, in which case said actuator rod (11) is, as is illustrated in Figs. 9, 12, 14 and 17, first pushed upwards in the bar (5) in which it is fitted in a guided manner, without the bar (5) itself moving, until the actuator rod (11) is situated in its starting position. In the embodiment as illustrated in Figs. 8-10, the actuator rod (11) in this case moves up to the top side of the bar (5) of the shutter extension part (4). In the embodiment as illustrated in Figs. 11 to 17, the actuator rod (11) is additionally connected to the bar (5) by means of an entrainment element (26) which determines said starting position. Here, the bolt (27) - as a securing pin (27) by means of which the shutter extension part (4) is attached to the guide piece (17) - is provided to this end in a guided manner in an entrainment slot (28) of the entrainment element (26) which is fixedly connected to the bar (5) of the shutter extension part (4). Said bolt (27) is furthermore fixedly connected to the actuator rod (11) by means of a securing plate (25). In the end position of the actuator rod (11), the bolt (27) is situated on the bottom side in the entrainment slot (28), as can be seen in Figs. 11, 13 and 16. In the starting position of the actuator rod (11), the bolt (27) is situated on the top side in the entrainment slot (28), as can be seen in Figs. 12, 14 and 17.

[0051] With this first movement, in which the actuator rod (11) is moved between its end position and its starting position, the locking pin (10) is lifted out of the locking opening (23) in the locking hook (9), as can be seen in Figs. 8-9, 11-14 and 16-17. The locking pin (10) is unhooked from the locking hook (9) and moves to the po-

sition illustrated in Figs. 6 and 7 via the slot (21) and the entry opening (22).

[0052] When the actuator rod (11) is moved upwards further by means of the pulling cable (7) or the toothed belt (24), the shutter extension part (4) is also made to move. In the embodiment illustrated in Figs. 8-10, the actuator rod (11) therefore carries the bar (5) and thus also the shutter extension part (4) along in its movement. In the embodiment illustrated in Figs. 11-17, the toothed belt (24) entrains the shutter extension part (4) by means of the guide piece (17), the bolt (27) and the entrainment element (26), due to the fact that the bolt (27) is situated on the top side in the entrainment slot (28). With both embodiments, this shutter extension part (4) now moves upwards pivotably with respect to the basic shutter part (3) and rotatably with respect to the guide profile (20). Between the closed position and the completely open position, the actuator rod (11) is first moved towards the top side of the bar (5), as described above, until, at a certain point, the shutter parts (3, 4) come to lie at such an angle with respect to the pulling cable (7) or the toothed belt (24), that the pulling cable (7) or the toothed belt (24) again move this actuator rod (11) towards the bottom side of the bar (5). In the completely open position of the folding shutter (1), said actuator rod (11) has been pulled to its lowest spot in the bar (5), in the vicinity of the bottom side of the shutter extension part (4), back into its end position, as can be seen in Fig. 10.

[0053] Conversely, if, in the embodiment with a pulling cable (7), the folding shutter (1) is moved from its open position to its closed position, said pulling cable (7) will be unrolled from the disc (8), in which case the shutter extension part (4) is lowered on account of the force of gravity and the pulling force of the pulling cable (7) ensures that the downward movement takes place in a smooth and controlled manner. In the embodiment with the toothed belt (24), the toothed belt (24) takes the actuator rod (11) and the shutter extension part (4) downwards in an opposite movement. The shutter extension part (4) will move downwards on account of the force of gravity, while, in a first movement, the actuator rod (11) is pulled upwards in the bar (5) from its end position to its starting position, due to the fact that the pulling cable (7) retains the actuator rod (11) or because the toothed belt (24) retains the actuator rod (11), and is held at the top of this bar (5) in its starting position by the pulling cable (7) or the toothed belt (24) during virtually the entire downward movement of the shutter extension part (4). At the end of the downward movement, the locking pin (10) arrives at the location of the entry opening (22) of the locking hook (9) and said locking pin (10) engages in said locking hook (9) via said entry opening (22) and via the slot (21). In the embodiment with a pulling cable (7), the actuator rod (11) will only be lowered and engage in the locking opening (23) of the locking hook (9) via the locking pin (10) when the stress of the pulling cable (7) ceases. In the embodiment with a toothed belt (24), the toothed belt (24) takes the actuator rod (11) further down-

wards and moves it from its starting position back to its end position after the bar (5) of the shutter extension part (4) has reached the lowest point, but is still at an angle with respect to the guide profile (20). Due to the fact that the locking pin (10) in the locking slot (21) moves from the entry opening (22) to the locking opening (23), the shutter extension part (4) is pulled towards the guide profile (20) until it extends parallel thereto.

[0054] The above-described movement of the actuator rod (11) and the locking pin (10) attached thereto can be achieved by the force of gravity of the actuator rod (11) as counterforce counter to the pulling force of the pulling cable (7) or by the entrainment force of the toothed belt (24).

[0055] However, the folding shutters (1) illustrated in Figs. 1 to 10 additionally comprise a spring (18) in order to exert an additional counterforce on the actuator rod (11) on top of the force of gravity. In this way, the pulling force of the pulling cable (7) has to overcome both the force of gravity and the spring force as counterforce in order to be able to move the actuator rod (11) upwards during opening of the folding shutter (1) when releasing the locking pin (10) from the locking opening (23). Conversely, when closing the folding shutter (1), the spring force will be an additional force which provides additional security that the locking pin (10) is kept in the locking hook (9) in order to lock the folding shutter.

[0056] The embodiments illustrated in Figs. 11 to 17 additionally comprise a spring piece (29) which serves as a buffer should the locking pin (10) be temporarily stuck somewhere in the locking slot (21).

[0057] In the illustrated embodiments, the locking hook (9) and the locking pin (10) are centrally arranged between the fixed rotation shaft (A) and the displaceable rotation shaft (C), so that the folding shutter (1) is centrally locked between said rotation shafts (A, C) in its closed position. As a result thereof, flapping of the folding shutter (1) due to, for example, the wind is significantly reduced. This also has the advantage that a considerable distance is available for the locking pin (10) to engage in the locking hook (9), as a result of which a secure locking action can be achieved in a smooth manner.

45 Claims

1. Folding shutter (1), comprising

- a part (2, 20) which is immovable in the fitted position;
- a basic shutter part (3) which is attachable to the immovable part (2, 20) and is rotatable with respect to said immovable part (2, 20) about a fixed rotation shaft (A);
- one or more shutter extension parts (4) which is/are rotatable with respect to the immovable part (2, 20) about a displaceable rotation shaft (C), in which all said shutter parts are pivotably

connected to one another in a concertina-like manner and in which the folding shutter (1) is displaceable between a closed position, in which said shutter parts (3, 4) extend virtually in line with one another, and an open position, in which said shutter parts (3, 4) extend at an angle with respect to one another or parallel to one another as a result of a displacement of the displaceable rotation shaft (C);

- drive means (7, 8, 19, 24) which engage with one of said shutter extension parts (4) for driving the movement of the displaceable rotation shaft (C); and

- locking means (9, 10), comprising first locking means (9) which are attached to the immovable part and second locking means (10) which are attached to one of said shutter parts (3, 4), in which the locking means (9, 10) engage with each other in order to lock the folding shutter (1) in the closed position when the folding shutter (1) is moved to the closed position;

characterized in that

the folding shutter (1) comprises an actuator rod (11) which is attached to the last-mentioned shutter extension part (4) virtually at right angles to the displaceable rotation shaft (C), the actuator rod (11) being arranged as to be movable in a bar (5) of this shutter extension part (4), between a starting position and an end position, said bar (5) being designed as a guide profile, in which the actuator rod (11) can be moved in a guided manner, in which said drive means (7, 8, 19, 24) are connected to said actuator rod (11) in order to drive the movement of the actuator rod (11), the movement of the actuator rod (11) being driven asynchronously with respect to the movement of the shutter extension part (4) with which the drive means (7, 8, 19, 24) engage, and in which the second locking means (10) are attached to said actuator rod (11) in order to attach said second locking means (10) to the respective shutter part (3, 4), in such a manner that when the folding shutter (1) is moved to the closed position, the locking means (9, 10) engage with each other at the end of said displacement, when the actuator rod (11) is moved from its starting position to its end position.

2. Folding shutter (1) according to Claim 1, **characterized in that** the first locking means (9) comprise a locking hook (9) and the second locking means (10) comprise a locking pin (10) which engages in the locking hook (9) when the folding shutter (1) is moved to the closed position.
3. Folding shutter (1) according to one of the preceding claims, **characterized in that** the locking hook (9) comprises a hook-shaped slot (21) having an entry opening (22) and a locking opening (23), in which

the locking pin (10), when it engages in the locking hook (9), is taken from the entry opening (22) to the locking opening (23) via the hook-shaped slot (21) and in which the entry opening (23) is designed to be wider than the diameter of the locking pin (10) and the dimensions of the locking opening (23) virtually correspond to the diameter of the locking pin (10).

4. Folding shutter (1) according to one of the preceding claims, **characterized in that** the folding shutter (1) comprises counteracting means (11, 18) which exert a counterforce on the actuator rod (11), counter to the force with which the drive means (7, 8, 19, 24) engage on the actuator rod (11) when moving the folding shutter (1) into its closed position, so that the locking means (9, 10) engage with each other on account of this counterforce when the folding shutter (1) is moved into its closed position.
5. Folding shutter (1) according to Claim 4, **characterized in that** the counteracting means (11, 18) comprise a spring (18), in which the spring force of said spring (18) forms part of the counterforce.
6. Folding shutter (1) according to Claim 4 or 5, **characterized in that** the actuator rod (11) forms part of the counteracting means (11, 18), in which the force of gravity on said actuator rod (11) forms part of the counterforce.
7. Folding shutter (1) according to one of the preceding claims, **characterized in that** said rotation shafts (A, C) extend virtually horizontally in the fitted position of the folding shutter (1).
8. Folding shutter (1) according to Claims 6 and 7, **characterized in that** the drive means (7, 8, 19, 24) comprise a pulling cable (7) and a disc (8), in which one end of the pulling cable (7) is connected to the actuator rod (11) and the other end is connected to the disc (8) and said pulling cable (7) can be rolled onto said disc (8).
9. Folding shutter (1) according to one of Claims 1 to 7, **characterized in that** the drive means (7, 8, 19, 24) comprise a toothed belt (24), in which the actuator rod (11) is connected to the toothed belt (24) in order to connect the latter to the drive means (7, 8, 19, 24).
10. Folding shutter (1) according to one of the preceding claims, **characterized in that** the shutter extension part (4) is connected to the actuator rod (11) by means of an entrainment element (26) and an entrainment pin (27), with the entrainment element (26) being fixedly connected to the shutter extension part (4) and being provided with an entrainment slot (28)

in which the entrainment pin (27) is received and with the entrainment pin (27) being fixedly connected to the actuator rod (11).

11. Folding shutter (1) according to one of the preceding claims, **characterized in that** the second locking means (10) and the drive means (7, 8, 19, 24) are connected to said actuator rod (11) virtually at the location of the two opposite ends of the actuator rod (11). 5
12. Folding shutter (1) according to one of the preceding claims, **characterized in that** the drive means (7, 8, 19, 24) are connected to the actuator rod (11) in the vicinity of the displaceable rotation shaft (C). 10
13. Folding shutter (1) according to one of the preceding claims, **characterized in that** the shutter extension part (4) to which the actuator rod (11) is connected, is pivotably attached to the basic shutter part (3), so that the basic shutter part (3) and said shutter extension part (4) are rotatable with respect to one another about a hinging rotation shaft (B). 20
14. Folding shutter (1) according to Claim 10, **characterized in that** the second locking means (10) are connected to the actuator rod (11) in the vicinity of the hinging rotation shaft (B). 25
15. Folding shutter (1) according to one of the preceding claims, **characterized in that** the shutter extension part (4) comprises a guide profile (5), in which the actuator rod (11) is fitted in a guided manner. 30

Patentansprüche

1. Klappladen (1), umfassend

- ein Teil (2, 20), das in Einbauposition unbeweglich ist; 40
- ein Grundladenteil (3), das an dem unbeweglichen Teil (2, 20) befestigt werden kann und in Bezug auf das unbewegliche Teil (2, 20) um eine feste Drehachse (A) drehbar ist; 45
- eines oder mehrere Ladenverlängerungsteile (4), das/die in Bezug auf das unbewegliche Teil (2, 20) um eine verschiebbare Drehachse (C) drehbar ist/sind, wobei alle Ladenteile zieharmonikaartig schwenkbar miteinander verbunden sind, wobei der Klappladen (1) zwischen einer geschlossenen Position, bei der sich die Ladenteile (3, 4) nahezu in einer Linie zueinander erstrecken, und einer offenen Position, bei der sich die Ladenteile (3, 4) in einem Winkel in Bezug aufeinander oder parallel zueinander erstrecken, als Ergebnis einer Verschiebung der verschiebbaren Drehwelle (C) verschiebbar ist; 50

- Antriebsmittel (7, 8, 19, 24), die in eines der Ladenverlängerungsteile (4) zum Antreiben der Bewegung der verschiebbaren Drehachse (C) eingreifen; und

- Sperrmittel (9, 10), umfassend ein erstes Sperrmittel (9), das mit dem unbeweglichen Teil verbunden ist und ein zweites Sperrmittel (10), das an einem der Ladenteile (3, 4) befestigt ist, wobei die Sperrmittel (9, 10) ineinander eingreifen, um den Klappladen (1) in der geschlossenen Position zu sperren, wenn der Klappladen (1) zu der geschlossenen Position bewegt wird;

dadurch gekennzeichnet, dass

der Klappladen (1) eine Betätigungsstange (11) umfasst, die an dem letztgenannten Ladenverlängerungsteil (4) nahezu im rechten Winkel zu der verschiebbaren Drehwelle (C) befestigt ist, wobei die Betätigungsstange (11) angeordnet ist, um in einem Stab (5) des Ladenverlängerungsteils (4) zwischen einer Startposition und einer Endposition beweglich zu sein, wobei der Stab (5) als ein Führungsprofil ausgestaltet ist, in dem die Betätigungsstange (11) geführt bewegt werden kann, wobei die Antriebsmittel (7, 8, 19, 24) mit der Betätigungsstange (11) verbunden sind, um die Bewegung der Betätigungsstange (11) anzutreiben, wobei die Bewegung der Betätigungsstange (11) asynchron in Bezug auf die Bewegung des Ladenverlängerungsteils (4) angetrieben wird, mit der die Antriebsmittel (7, 8, 19, 24) in Eingriff gebracht werden, und wobei das zweite Sperrmittel (10) an der Betätigungsstange (11) befestigt ist, um das zweite Sperrmittel (10) an dem zugehörigen Ladenteil (3, 4) derart zu befestigen, dass, wenn der Klappladen (1) zu der geschlossenen Position bewegt wird, die Sperrmittel (9, 10) am Ende der Verschiebung ineinander eingreifen, wenn die Betätigungsstange (11) von ihrer Start- zu ihrer Endposition bewegt wird. 35

2. Klappladen (1) nach Anspruch 1, **dadurch gekennzeichnet, dass** das erste Sperrmittel (9) einen Sperrhaken (9) und das zweite Sperrmittel (10) einen Sperrstift (10) umfassen, der in den Sperrhaken (9) eingreift, wenn der Klappladen (1) zur geschlossenen Position bewegt wird.

3. Klappladen (1) nach einem der vorhergehenden Ansprüche, **dadurch gekennzeichnet, dass** der Sperrhaken (9) einen hakenförmigen Schlitz (21) umfasst, der eine Eintrittsöffnung (22) aufweist, und eine Sperröffnung (23), in welcher der Sperrstift (10), wenn er in den Sperrhaken (9) eingreift, von der Eintrittsöffnung (22) zur Sperröffnung (23) über den hakenförmigen Schlitz (21) mitgenommen wird, wobei die Eintrittsöffnung (23) ausgestaltet ist, um breiter als der Durchmesser des Sperrstifts (10) zu sein, und die Abmessungen der Sperröffnung (23) nahezu

- dem Durchmesser des Sperrstifts (10) entsprechen.
4. Klappladen (1) nach einem der vorhergehenden Ansprüche, **dadurch gekennzeichnet, dass** der Klappladen (1) Gegenwirkmittel (11, 18) umfasst, die eine Gegenkraft auf die Betätigungsstange (11) gegen die Kraft ausüben, mit der die Antriebsmittel (7, 8, 19, 24) in die Betätigungsstange (11) eingreifen, wenn der Klappladen (1) in die geschlossene Position bewegt wird, sodass die Sperrmittel (9, 10) in Abhängigkeit dieser Gegenkraft ineinander eingreifen, wenn der Klappladen (1) in seine geschlossene Position bewegt wird.
 5. Klappladen (1) nach Anspruch 4, **dadurch gekennzeichnet, dass** die Gegenwirkmittel (11, 18) eine Feder (18) umfassen, wobei die Federkraft der Feder (18) Teil der Gegenkraft bildet.
 6. Klappladen (1) nach Anspruch 4 oder 5, **dadurch gekennzeichnet, dass** die Betätigungsstange (11) Teil der Gegenwirkmittel (11, 18) ist, wobei die Schwerkraft, die auf die Betätigungsstange (11) ausgeübt wird, Teil der Gegenkraft ist.
 7. Klappladen (1) nach einem der vorhergehenden Ansprüche, **dadurch gekennzeichnet, dass** sich die Drehachsen (A, C) in der Einbauposition des Klappladens (1) nahezu horizontal erstrecken.
 8. Klappladen (1) nach einem der Ansprüche 6 und 7, **dadurch gekennzeichnet, dass** die Antriebsmittel (7, 8, 19, 24) ein Zugseil (7) und eine Scheibe (8) umfassen, wobei ein Ende des Zugseils (7) mit der Betätigungsstange (11) verbunden ist und das andere Ende mit der Scheibe (8) verbunden ist und das Zugseil (7) auf die Scheibe (8) aufgerollt werden kann.
 9. Klappladen (1) nach einem der Ansprüche 1 bis 7, **dadurch gekennzeichnet, dass** die Antriebsmittel (7, 8, 19, 24) einen Zahnriemen (24) umfassen, wobei die Betätigungsstange (11) mit dem Zahnriemen (24) verbunden ist, um diesen mit den Antriebsmitteln (7, 8, 19, 24) zu verbinden.
 10. Klappladen (1) nach einem der vorhergehenden Ansprüche, **dadurch gekennzeichnet, dass** das Ladenverlängerungsteil (4) mit der Betätigungsstange (11) mittels eines Mitnehmerelements (26) und eines Mitnehmerstifts (27) verbunden ist, wobei das Mitnehmerelement (26) fest mit dem Ladenverlängerungsteil (4) verbunden ist und mit einem Mitnehmerschlitz (28) bereitgestellt ist, in dem der Mitnehmerstift (27) aufgenommen ist, wobei der Mitnehmerstift (27) fest mit der Betätigungsstange (11) verbunden ist.
 11. Klappladen (1) nach einem der vorhergehenden Ansprüche, **dadurch gekennzeichnet, dass** das zweite Sperrmittel (10) und die Antriebsmittel (7, 8, 19, 24) mit der Betätigungsstange (11) nahezu an der Stelle der zwei gegenüberliegenden Enden der Betätigungsstange (11) verbunden sind.
 12. Klappladen (1) nach einem der vorhergehenden Ansprüche, **dadurch gekennzeichnet, dass** die Antriebsmittel (7, 8, 19, 24) mit der Betätigungsstange (11) in der Nähe der verschiebbaren Drehwelle (C) verbunden sind.
 13. Klappladen (1) nach einem der vorhergehenden Ansprüche, **dadurch gekennzeichnet, dass** das Ladenverlängerungsteil (4), mit dem die Betätigungsstange (11) verbunden ist, schwenkbar an dem Grundladenteil (3) befestigt ist, so dass das Grundladenteil (3) und das Ladenverlängerungsteil (4) um eine Gelenkdrehachse (B) in Bezug aufeinander drehbar sind.
 14. Klappladen (1) nach Anspruch 10, **dadurch gekennzeichnet, dass** die zweiten Sperrmittel (10) mit der Betätigungsstange (11) in der Nähe der Gelenkdrehachse (B) verbunden sind.
 15. Klappladen (1) nach einem der vorhergehenden Ansprüche, **dadurch gekennzeichnet, dass** das Ladenverlängerungsteil (4) ein Führungsprofil (5) umfasst, in das die Betätigungsstange (11) führbar eingebaut ist.
- ### 35 Revendications
1. Volet pliant (1), comprenant:
 - une partie (2, 20) qui est immobile dans la position agencée;
 - une partie de volet de base (3) qui peut être attachée à la partie immobile (2, 20) et qui est rotative par rapport à ladite partie immobile (2, 20) autour d'un arbre de rotation fixe (A);
 - une ou plusieurs partie(s) d'extension de volet (4) qui est (sont) rotative (s) par rapport à la partie immobile (2, 20) autour d'un arbre de rotation déplaçable (C), dans lequel toutes lesdites parties de volet sont connectées de façon pivotante l'une à l'autre en accordéon, et dans lequel le volet pliant (1) est déplaçable entre une position fermée, dans laquelle lesdites parties de volet (3, 4) s'étendent virtuellement en ligne l'une avec l'autre, et une position ouverte, dans laquelle lesdites parties de volet (3, 4) s'étendent à un angle l'une par rapport à l'autre ou parallèlement l'une à l'autre à la suite d'un déplacement de l'arbre de rotation déplaçable (C);

des moyens d'entraînement (7, 8, 19, 24) qui s'engagent avec l'une desdites parties d'extension de volet (4) pour entraîner le déplacement de l'arbre de rotation déplaçable (C); et des moyens de verrouillage (9, 10) comprenant des premiers moyens de verrouillage (9) qui sont attachés à la partie immobile, et des seconds moyens de verrouillage (10) qui sont attachés à l'une desdites parties de volet (3, 4), dans lequel les moyens de verrouillage (9, 10) s'engagent mutuellement dans le but de verrouiller le volet pliant (1) dans la position fermée lorsque le volet pliant (1) est déplacé vers la position fermée,

caractérisé en ce que le volet pliant (1) comprend une bielle (11) qui est attachée à la dernière partie d'extension de volet mentionnée (4) virtuellement à angle droit par rapport à l'arbre de rotation déplaçable (C), la bielle (11) étant agencée de manière à être mobile dans une barre (5) de cette partie d'extension de volet (4), entre une position de départ et une position d'arrivée, ladite barre (5) étant conçue comme un profilé de guidage, dans lequel la bielle (11) peut être déplacée d'une manière guidée, dans lequel lesdits moyens d'entraînement (7, 8, 19, 24) sont connectés à ladite bielle (11) dans le but d'entraîner le déplacement de la bielle (11), le déplacement de la bielle (11) étant entraîné de façon asynchrone par rapport au déplacement de la partie d'extension de volet (4) avec laquelle les moyens d'entraînement (7, 8, 19, 24) s'engagent, et dans lequel les seconds moyens de verrouillage (10) sont attachés à ladite bielle (11) dans le but d'attacher lesdits seconds moyens de verrouillage (10) à la partie de volet respective (3, 4) de telle sorte que lorsque le volet pliant (1) est déplacé vers la position fermée, les moyens de verrouillage (9, 10) s'engagent l'un avec l'autre à la fin dudit déplacement, lorsque la bielle (11) est déplacée à partir de sa position de départ jusqu'à sa position d'arrivée.

2. Volet pliant (1) selon la revendication 1, **caractérisé en ce que** les premiers moyens de verrouillage (9) comprennent un crochet de verrouillage (9) et les seconds moyens de verrouillage (10) comprennent une broche de verrouillage (10) qui s'engage dans le crochet de verrouillage (9) lorsque le volet pliant (1) est déplacé vers la position fermée.
3. Volet pliant (1) selon l'une des revendications précédentes, **caractérisé en ce que** le crochet de verrouillage (9) comporte une fente en forme de crochet (21) présentant une ouverture d'entrée (22) et une ouverture de verrouillage (23), dans lequel la broche de verrouillage (10), lorsqu'elle s'engage dans le crochet de verrouillage (9), est conduite de l'ouverture d'entrée (22) à l'ouverture de verrouillage (23) par

l'intermédiaire de la fente en forme de crochet (21), et dans lequel l'ouverture d'entrée (23) est conçue de manière à être plus large que le diamètre de la broche de verrouillage (10), et les dimensions de l'ouverture de verrouillage (23) correspondent virtuellement au diamètre de la broche de verrouillage (10).

4. Volet pliant (1) selon l'une des revendications précédentes, **caractérisé en ce que** le volet pliant (1) comprend des moyens d'action contraire (11, 18) qui exercent une contre-force sur la bielle (11), opposée à la force avec laquelle les moyens d'entraînement (7, 8, 19, 24) s'engagent sur la bielle (11) lorsque l'on déplace le volet pliant (1) dans sa position fermée, de telle sorte que les moyens de verrouillage (9, 10) s'engagent mutuellement sous l'effet de cette contre-force lorsque le volet pliant (1) est déplacé dans sa position fermée.
5. Volet pliant (1) selon la revendication 4, **caractérisé en ce que** les moyens d'action contraire (11, 18) comprennent un ressort (18), dans lequel la force élastique dudit ressort (18) fait partie de la contre-force.
6. Volet pliant (1) selon la revendication 4 ou 5, **caractérisé en ce que** la bielle (11) fait partie des moyens d'action contraire (11, 18), dans lequel la force de gravité sur ladite bielle (11) fait partie de la contre-force.
7. Volet pliant (1) selon l'une des revendications précédentes, **caractérisé en ce que** lesdits arbres de rotation (A, C) s'étendent virtuellement horizontalement dans la position agencée du volet pliant (1).
8. Volet pliant (1) selon la revendication 6 et 7, **caractérisé en ce que** les moyens d'entraînement (7, 8, 19, 24) comprennent un câble de traction (7) et un disque (8), dans lequel une première extrémité du câble de traction (7) est connectée à la bielle (11), et l'autre extrémité est connectée au disque (8), et ledit câble de traction (7) peut être enroulé sur ledit disque (8).
9. Volet pliant (1) selon l'une des revendications 1 à 7, **caractérisé en ce que** les moyens d'entraînement (7, 8, 19, 24) comprennent une courroie dentée (24), dans lequel la bielle (11) est connectée à la courroie dentée (24) dans le but de connecter cette dernière aux moyens d'entraînement (7, 8, 19, 24).
10. Volet pliant (1) selon l'une des revendications précédentes, **caractérisé en ce que** la partie d'extension de volet (4) est connectée à la bielle (11) au moyen d'un élément d'entraînement (26) et d'une broche d'entraînement (27), l'élément d'entraîne-

ment (26) étant connecté fixement à la partie d'extension de volet (4) et comportant une fente d'entraînement (28) dans laquelle la broche d'entraînement (27) est reçue, et la broche d'entraînement (27) étant connectée fixement à la bielle (11).

5

11. Volet pliant (1) selon l'une des revendications précédentes, **caractérisé en ce que** les seconds moyens de verrouillage (10) et les moyens d'entraînement (7, 8, 19, 24) sont connectés à ladite bielle (11) virtuellement à l'endroit des deux extrémités opposées de la bielle (11).
12. Volet pliant (1) selon l'une des revendications précédentes, **caractérisé en ce que** les moyens d'entraînement (7, 8, 19, 24) sont connectés à la bielle (11) dans le voisinage de l'arbre de rotation déplaçable (C).
13. Volet pliant (1) selon l'une des revendications précédentes, **caractérisé en ce que** la partie d'extension de volet (4) à laquelle la bielle (11) est connectée est attachée de façon pivotante à la partie de volet de base (3), de telle sorte que la partie de volet de base (3) et ladite partie d'extension de volet (4) soient rotatives l'une par rapport à l'autre autour d'un arbre de rotation articulé (B).
14. Volet pliant (1) selon la revendication 10, **caractérisé en ce que** les seconds moyens de verrouillage (10) sont connectés à la bielle (11) dans le voisinage de l'arbre de rotation articulé (B).
15. Volet pliant (1) selon l'une des revendications précédentes, **caractérisé en ce que** la partie d'extension de volet (4) comprend un profilé de guidage (5), dans lequel la bielle (11) est agencée d'une façon guidée.

10

15

20

25

30

35

40

45

50

55

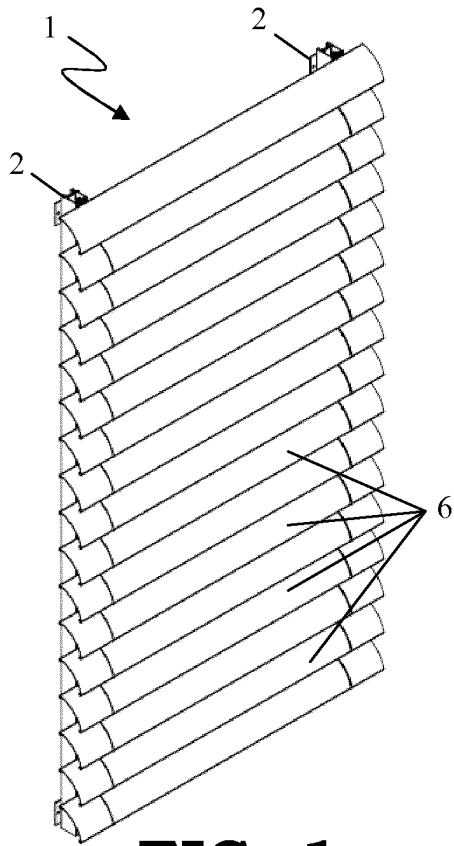

FIG. 1

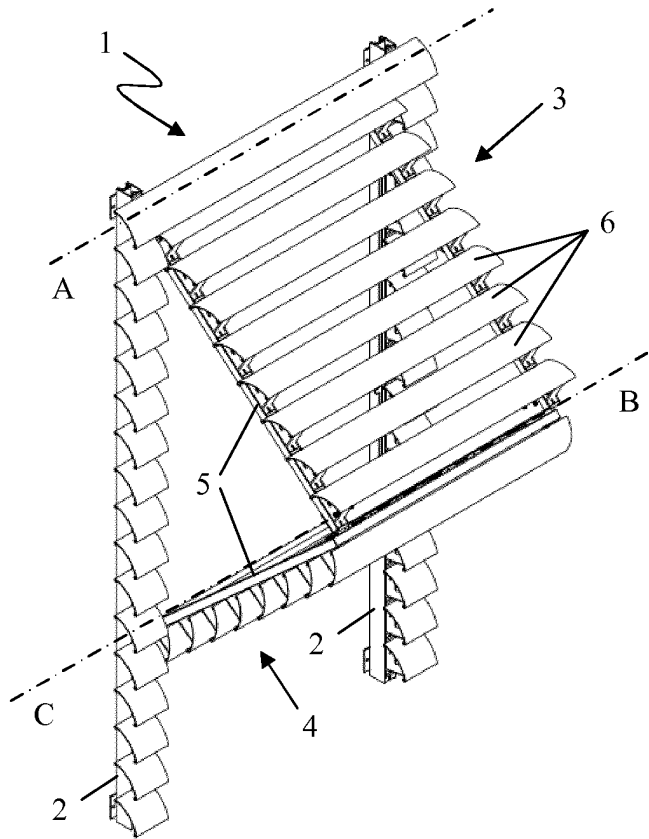

FIG. 2

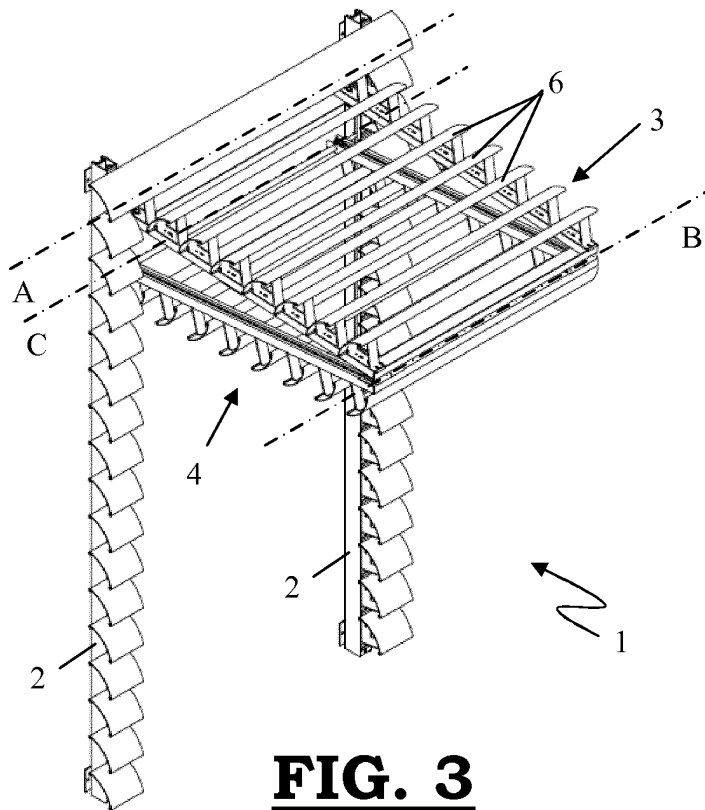

FIG. 3

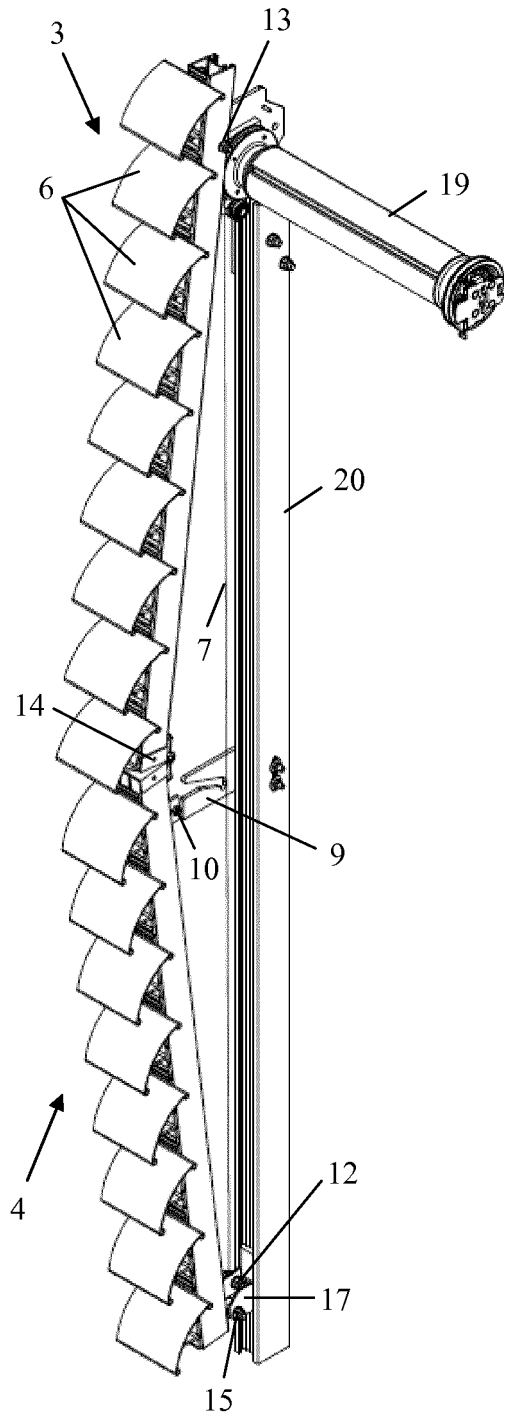

FIG. 4

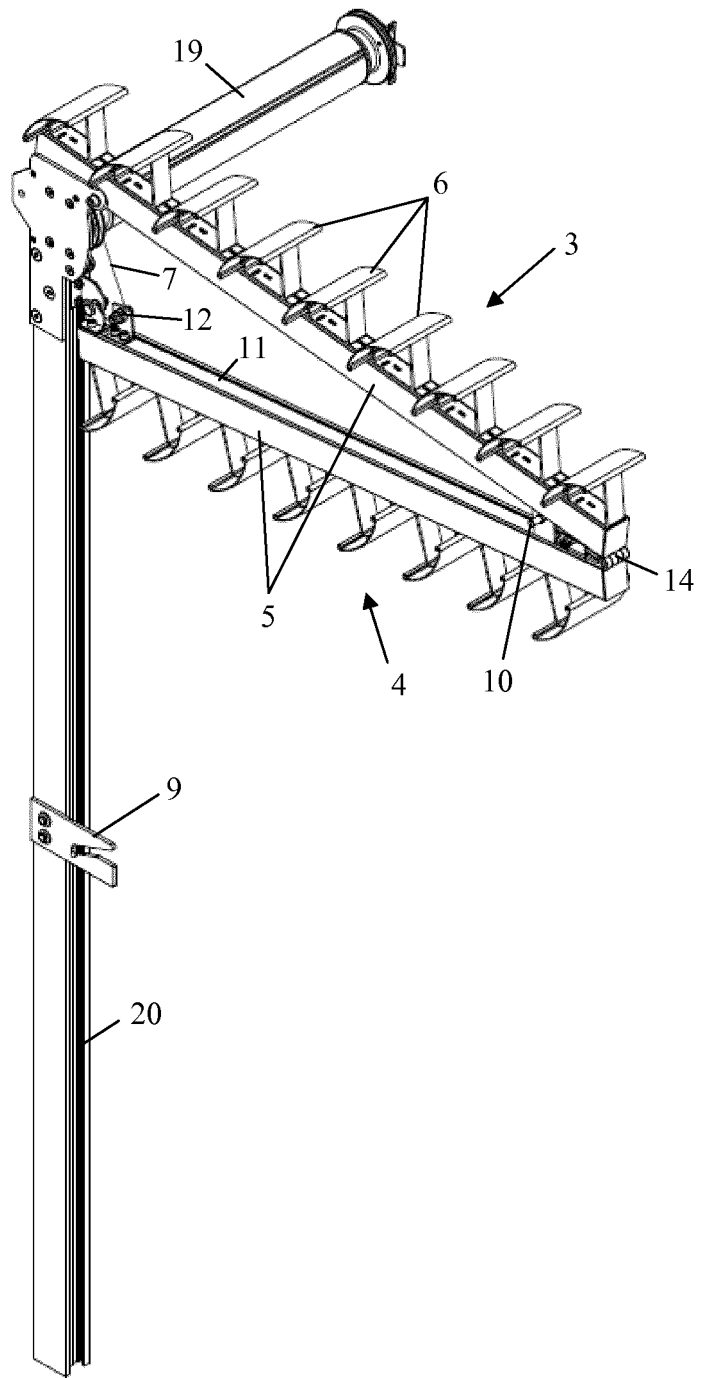
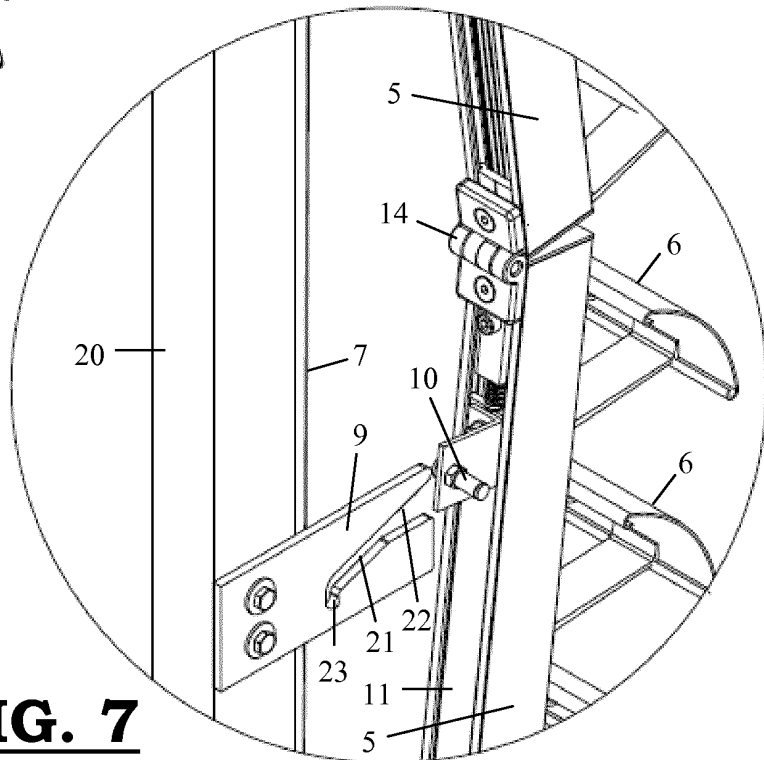
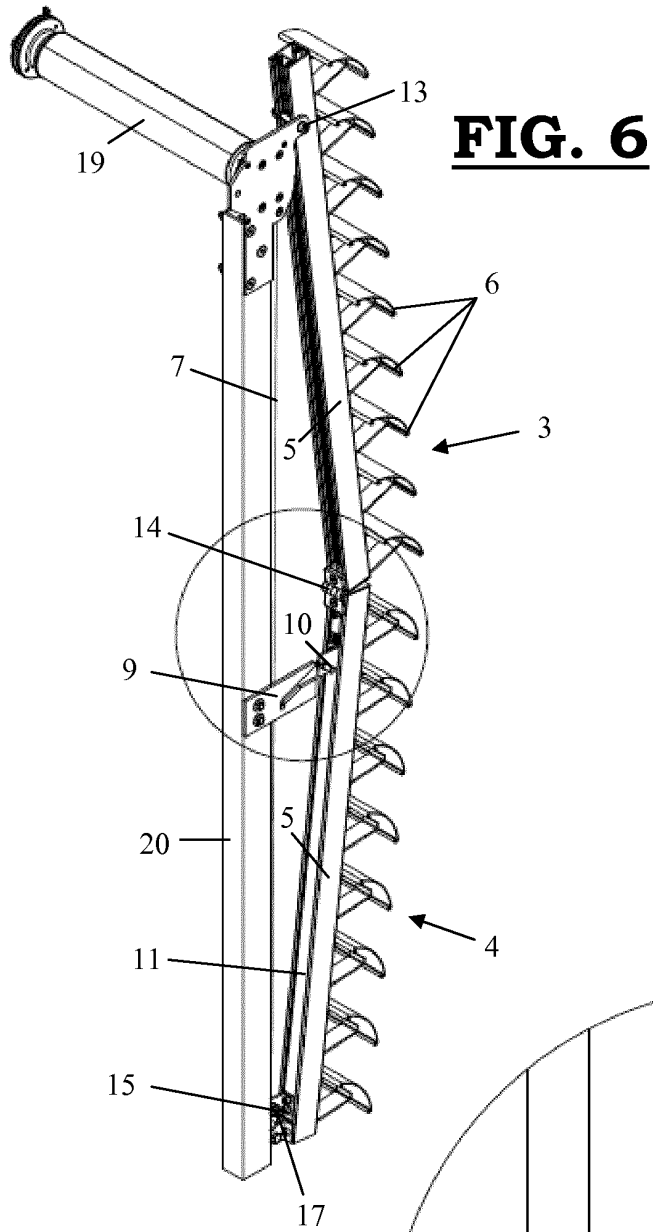

FIG. 5



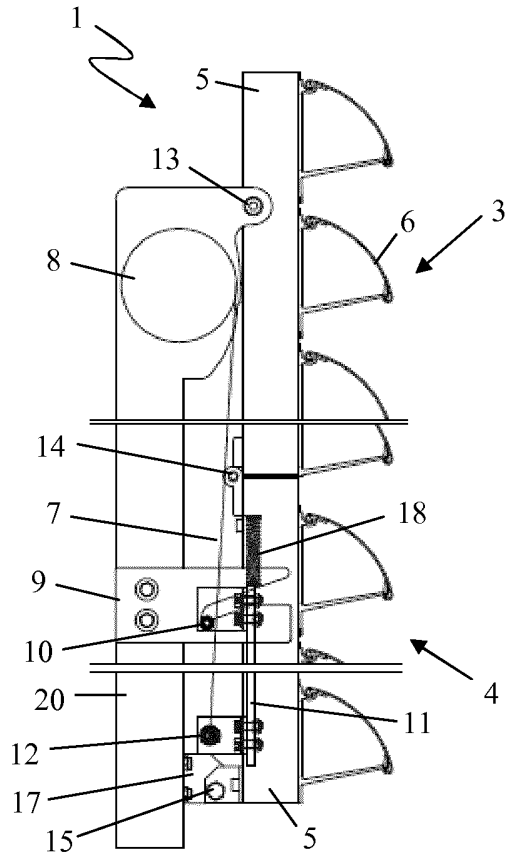

FIG. 8

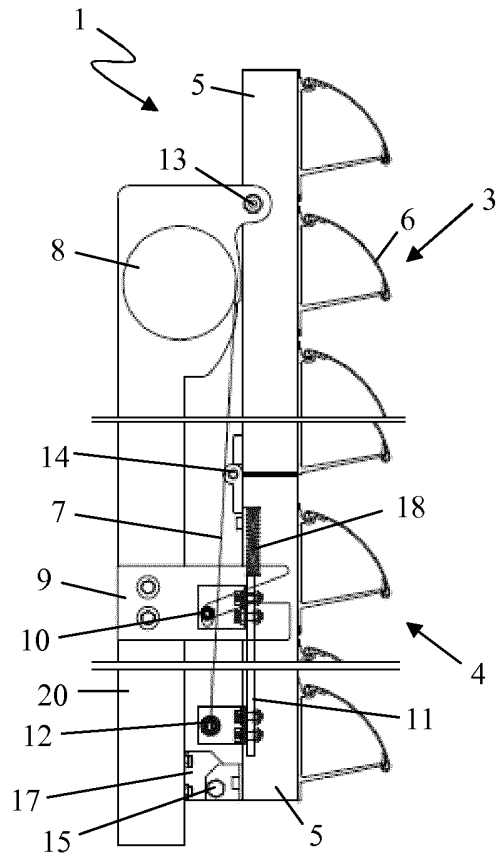

FIG. 9

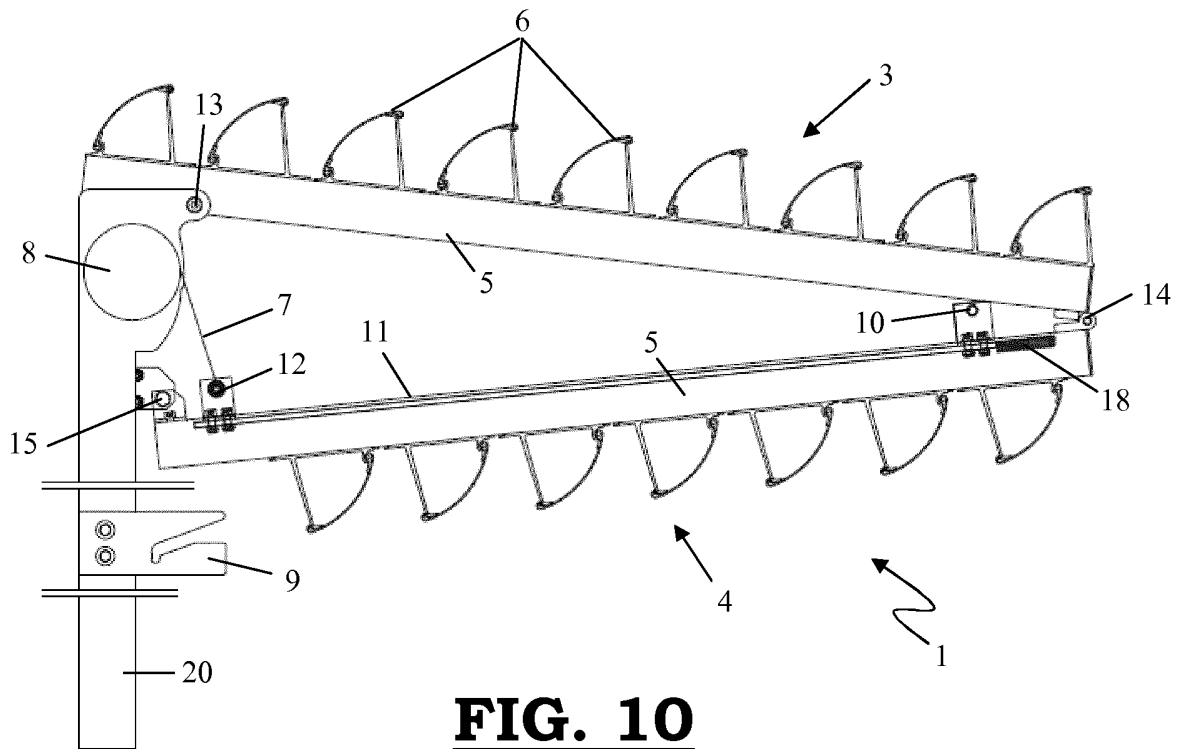

FIG. 10

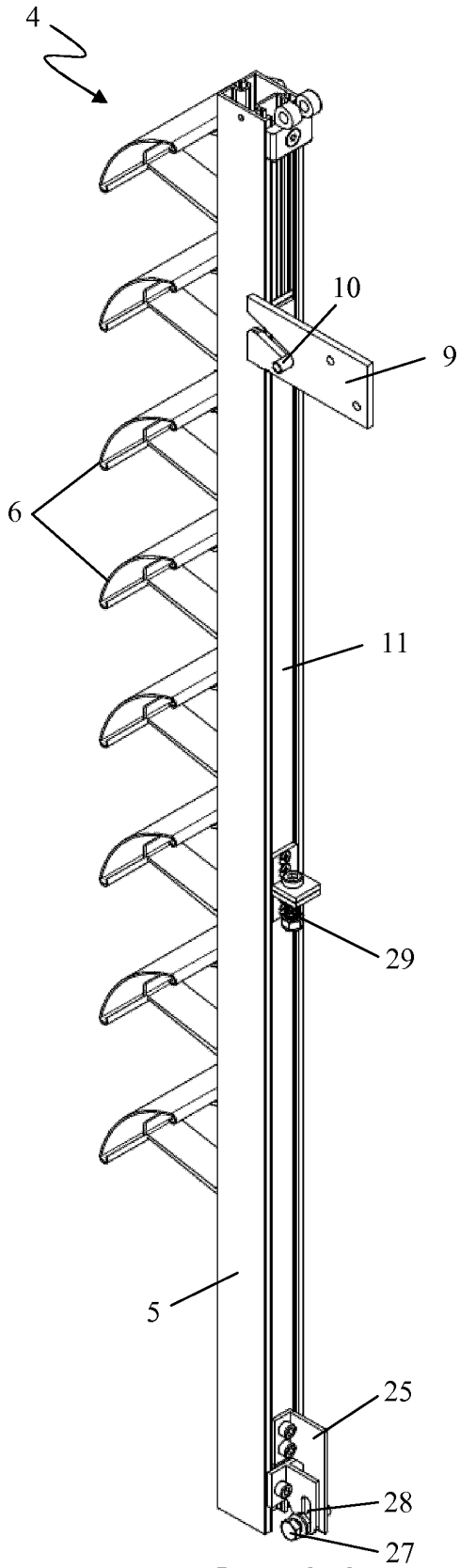

FIG. 11

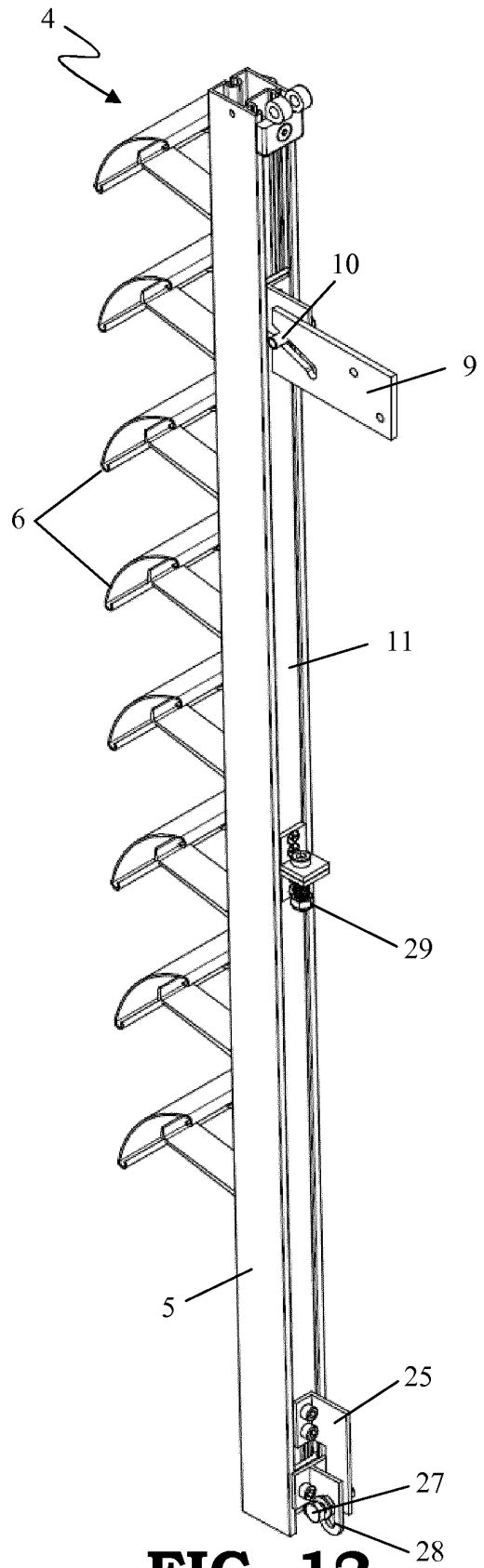

FIG. 12

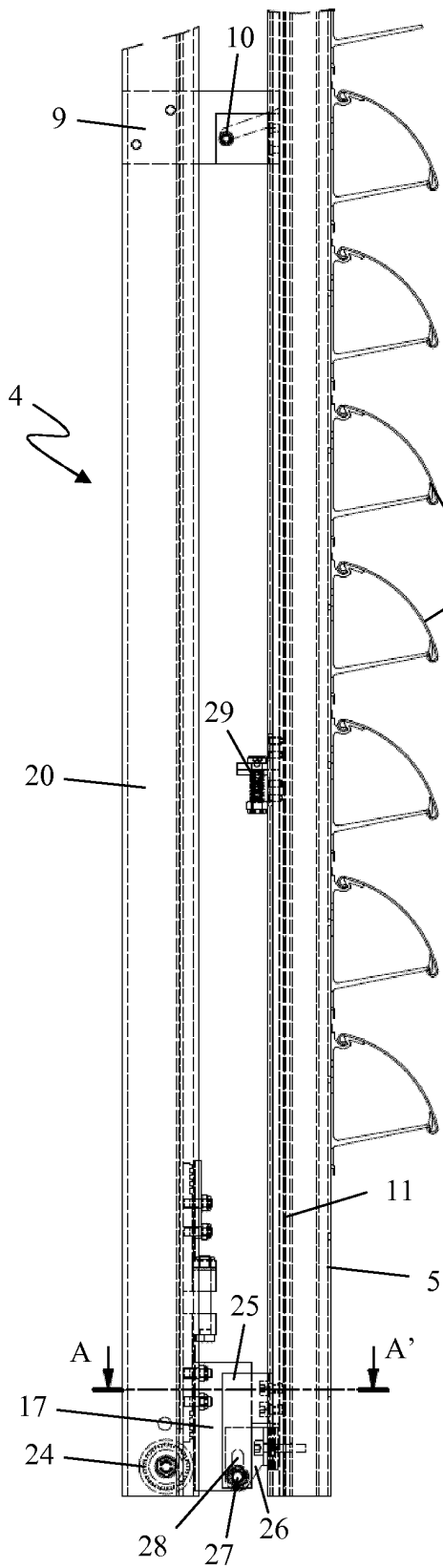

FIG. 13

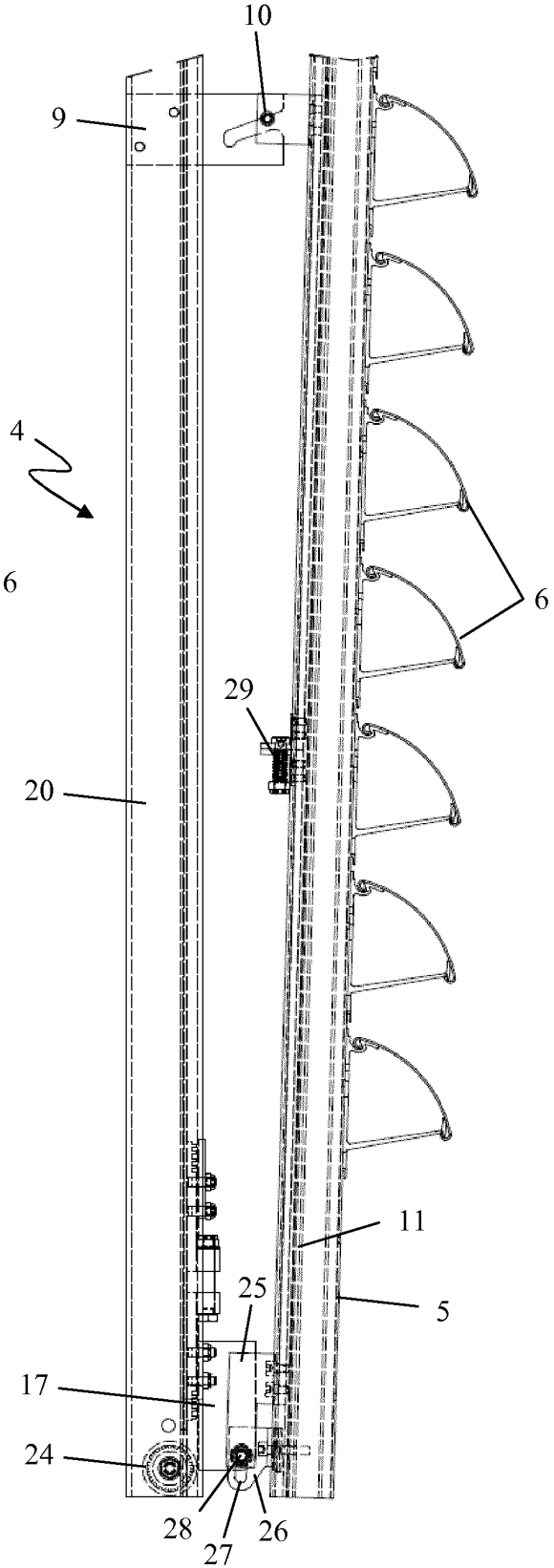

FIG. 14

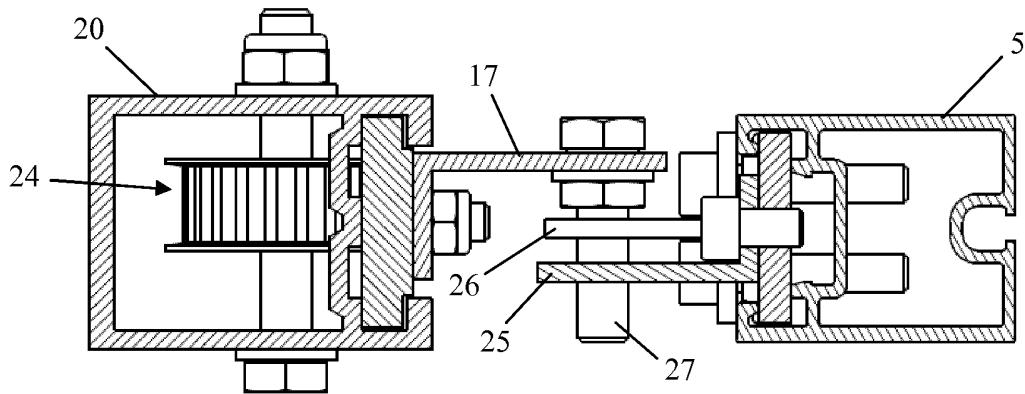

FIG. 15

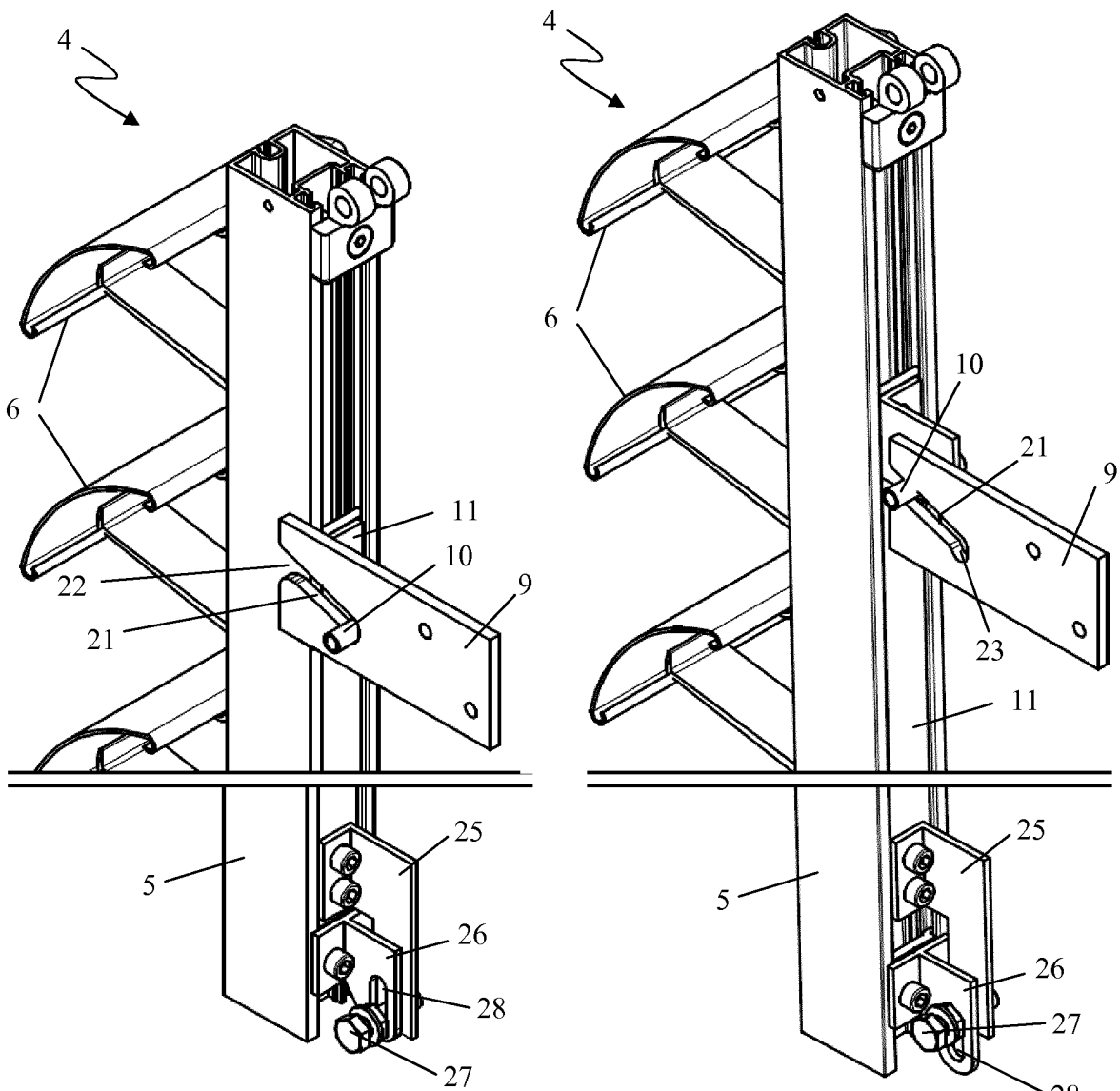

FIG. 16

FIG. 17

REFERENCES CITED IN THE DESCRIPTION

This list of references cited by the applicant is for the reader's convenience only. It does not form part of the European patent document. Even though great care has been taken in compiling the references, errors or omissions cannot be excluded and the EPO disclaims all liability in this regard.

Patent documents cited in the description

- US 20100282418 A1 [0006]