



(11) **EP 2 540 956 A1**

(12) **EUROPEAN PATENT APPLICATION**

(43) Date of publication:  
**02.01.2013 Bulletin 2013/01**

(51) Int Cl.:  
**E21B 33/064<sup>(2006.01)</sup> E21B 33/076<sup>(2006.01)</sup>**

(21) Application number: **11172161.9**

(22) Date of filing: **30.06.2011**

(84) Designated Contracting States:  
**AL AT BE BG CH CY CZ DE DK EE ES FI FR GB GR HR HU IE IS IT LI LT LU LV MC MK MT NL NO PL PT RO RS SE SI SK SM TR**  
Designated Extension States:  
**BA ME**

- **Vasques, Ricardo Reves**  
**2840 Holte (DK)**
- **Iversen, Morten**  
**N-2090 Hurdal Hurdal (NO)**
- **Macaulay, Malcolm**  
**The Woodlands, TX. 77384 (US)**

(71) Applicant: **Welltec A/S**  
**3450 Allerød (DK)**

(74) Representative: **Hoffmann Dragsted A/S**  
**Rådhuspladsen 16**  
**1550 Copenhagen V (DK)**

(72) Inventors:

- **Hallundbaek, Jørgen**  
**3230 Græsted (DK)**

(54) **Blowout preventer and well intervention tool**

(57) The present invention relates to a blowout preventer (1) for being mounted on a well head (2), comprising a plurality of valves (3,4) arranged in fluid communication with each other, connected and forming a tubular pipe enclosing a cavity (10) being in fluid communication with the well head when the blowout preventer is mounted onto the well head and at least one plug (37) in the well head has been removed, wherein the blowout preventer further comprises a chamber (6) and a piston (7) ar-

ranged inside the chamber dividing the chamber into a first chamber part (8) and a second chamber part (9), the first chamber part being in fluid communication with the cavity and the second chamber part being filled with a compressible fluid, such as gas. Furthermore, the invention relates to a well intervention tool (100) and a well intervention system (200).

**EP 2 540 956 A1**

## Description

### Field of the Invention

**[0001]** The present invention relates to a blowout preventer for being mounted on a well head, comprising a plurality of valves arranged in fluid communication with each other, connected and forming a tubular pipe enclosing a cavity being in fluid communication with the well head when the blowout preventer is mounted onto the well head and at least one plug in the well head has been removed. Furthermore, the invention relates to a well intervention tool and a well intervention system.

### Background Art

**[0002]** Before intervening a well, the crown plugs need to be pulled in order to provide access to the well. The well may be situated 2000 metres below the surface of the sea, resulting in a substantial amount of pressure acting upon the plug to be pulled, said pressure often being larger than the pressure in the well. The tool for pulling the plug then has to provide a force overcoming the pressure from the water column above the plug and often also the drag force applied from the lower pressure in the well.

**[0003]** Some pulling tools anchor up inside the lubricator connected to the BOP being on top of the well head. In order to provide the force needed to pull a plug in deep water wells, the amount of force applied by the anchors to the lubricator requires a redesign of the lubricator in order for the lubricator to be able to withstand such anchoring force.

### Summary of the Invention

**[0004]** It is an object of the present invention to wholly or partly overcome the above disadvantages and drawbacks of the prior art. More specifically, it is an object to provide an improved blowout preventer or intervention tool making it easier to pull a plug in the well head or X-mass tree, such as a crown plug.

**[0005]** The above objects, together with numerous other objects, advantages, and features, which will become evident from the below description, are accomplished by a solution in accordance with the present invention by a blowout preventer for being mounted on a well head, comprising:

- a plurality of valves arranged in fluid communication with each other, connected and forming a tubular pipe enclosing a cavity being in fluid communication with the well head when the blowout preventer is mounted onto the well head and at least one plug in the well head has been removed,

wherein the blowout preventer further comprises a chamber and a piston arranged inside the chamber dividing

the chamber into a first chamber part and a second chamber part, the first chamber part being in fluid communication with the cavity and the second chamber part being filled with a compressible fluid, such as gas.

**[0006]** By having such pressure reducing system in the form of the chamber and the piston, the pressure inside the blowout preventer can be substantially reduced, reducing the amount of force needed to pull the plug.

**[0007]** Also, the cavity may have a first pressure and the blowout preventer may further comprise a control device, such as a valve, for controlling the pressure in the cavity by letting fluid in the cavity into the first chamber part.

**[0008]** In one embodiment, the piston may be slidably arranged on a shaft arranged inside the chamber.

**[0009]** Furthermore, the chamber may be connected with the cavity by means of a flow channel.

**[0010]** Hereby, the chamber can be arranged at a distance from the tubular part of the blowout preventer and is easily implemented in existing blowout preventers, and the control device can be mounted on the flow channel so that the control device can be operated by an ROV, or manually or even remotely.

**[0011]** The blowout preventer as described above may further comprise a control unit comprising a storage device, and a communication unit for communicating with the control device.

**[0012]** Moreover, the blowout preventer as described above may comprise a sensor for sensing a pressure in the cavity.

**[0013]** The present invention also relates to a well intervention tool intended to be arranged in a lubricator for pulling a plug in a top part of a well head of a well for entering the well, the well head having an axial extension, comprising:

- a connection pulling unit having a connection unit for connection to the plug,
- a stroking tool having a tool housing and being connected to the connection pulling unit and providing an axial movement along the axial extension,
- a fixation unit for fixating the stroking tool in relation to the well head so that the axial movement of the stroking tool pulls the plug out of the well head,

wherein the stroking tool comprises a chamber and a piston arranged inside the chamber dividing the chamber into a first chamber part and a second chamber part, the first chamber part being in fluid communication with an opening in the tool housing and the second chamber part being filled with a compressible fluid, such as gas.

**[0014]** In one embodiment, the stroking tool may further comprise a control device, such as a valve, for letting fluid in through the opening of the housing into the first chamber part.

**[0015]** Moreover, the connection pulling unit may be a GS pulling tool.

**[0016]** Also, the piston may be slidably arranged on a

shaft arranged inside the chamber.

**[0017]** Furthermore, the control device may be arranged in the opening.

**[0018]** In addition, the stroking tool may be connected with the connection pulling unit by means of a stoker shaft.

**[0019]** In one embodiment, the fixating unit may comprise an anchoring section having anchors moving radially from the tool towards an inside wall of the lubricator.

**[0020]** In another embodiment, the fixating unit may be a tubular section surrounding part of the connection pulling tool for abutting a top part of the well head.

**[0021]** Further, the connection unit of the connection pulling unit may comprise latches for engaging inside the plug to be pulled.

**[0022]** The blowout preventer according to the present invention may further comprise a control unit comprising the storage device, and a communication unit for communicating with the control device.

**[0023]** Furthermore, the present invention relates to a well intervention system comprising:

- a blowout preventer according to the invention for connection onto a well head,
- a lubricator connectable to the blowout preventer, and
- an intervention tool according to the invention arranged inside the lubricator.

**[0024]** In one embodiment, the lubricator may be closed off at a first end by a blind cap.

**[0025]** In another embodiment, the lubricator may comprise a lubricator valve arranged to close off the lubricator at a second end of the lubricator opposite a first end.

**[0026]** Moreover, a shear ram valve may be connected with the lubricator valve.

**[0027]** Also, the intervention system may comprise a disconnection unit arranged between the lubricator valve and the blowout preventer for disconnecting a part of the system.

**[0028]** Further, the intervention tool may comprise a driving section, such as a downhole tractor.

**[0029]** Additionally, the intervention tool may be wireless and driven only by an internal power source.

**[0030]** By having a wireless intervention tool, a grease connector head is not needed in the end of the lubricator.

**[0031]** Said intervention tool may comprise an inductive coupling for charging or recharging power.

**[0032]** Also, the intervention system may further comprise a vehicle which is remotely operated.

#### Brief Description of the Drawings

**[0033]** The invention and its many advantages will be described in more detail below with reference to the accompanying schematic drawings, which for the purpose of illustration show some non-limiting embodiments and

in which

Fig. 1 shows a blowout preventer mounted on a well head,

Fig. 2 shows an well intervention system comprising a well intervention tool mounted on the blowout preventer, and

Fig. 3 shows another embodiment of the well intervention tool.

**[0034]** All the figures are highly schematic and not necessarily to scale, and they show only those parts which are necessary in order to elucidate the invention, other parts being omitted or merely suggested.

#### Detailed description of the invention

**[0035]** Fig. 1 shows a blowout preventer 1 mounted to a top part 22 of the well head 2 arranged on the seabed on deep water. The blowout preventer 1 comprises a plurality of valves 3, 4 arranged on top of each other, and thus in fluid communication with each other. The first valve is an annular valve 3 and the other valve may be a ram valve 4. The valves 3, 4 are connected and form part of a tubular pipe 5. At the end closest to the rams, the tubular pipe is connected with the well head 2, and at the other end, the tubular pipe may be connected with a lubricator comprising an well intervention tool 100 illustrated by dotted lines. Thus, the tubular pipe 5 encloses a cavity 10 which is in fluid communication with the well head when the blowout preventer is 1 mounted onto the well head 2 and at least one plug 37 in the well head has been removed by means of an intervention tool 100.

**[0036]** A lubricator 20 is arranged on top of the blowout preventer 1, said lubricator being arranged comprising the intervention tool capable of pulling the plug 37 and providing access to the well for a subsequent tool. The intervention tool 100 is powered by means of a wireline 24 extending through a grease injection head 21.

**[0037]** The blowout preventer 1 further comprises a pressure reducing system in the form of a chamber 6 and a piston 7. The piston 7 is arranged inside the chamber dividing the chamber into a first chamber part 8 and a second chamber part 9. The first chamber part 8 is in fluid communication with the cavity and the second chamber part 9 is filled with a compressible fluid, such as gas. The chamber is connected with the tubular pipe by means of a flow channel 15 providing the fluid communication between the cavity and the first chamber part. A control device 11, such as a valve, is arranged in the flow channel 15 for controlling the flow of fluid into the first chamber part 8. The control device 11 is closed when the lubricator 20 is connecting and subsequently, the control device 11 is opened, hence letting fluid from the cavity into the first chamber part 8, decreasing the pressure inside the blowout preventer 1 and the lubricator 20.

By decreasing the pressure inside the blowout preventer 1, the force acting on the plug 37 is also decreased substantially and the plug 37 is thus easier to pull.

**[0038]** By having a pressure reducing system in the form of a chamber with a piston, it is thus possible to equalise the pressure over the well head 2, so that the pressure in the blowout preventer 1 can be adjusted to be substantially the same as the pressure in the well below the plug or plugs.

**[0039]** Inside the chamber, the piston is slidably arranged on a shaft 12 which is also inside the chamber. In this way, the movement of the piston is controlled so that the piston does not tilt and jam if further movement of the piston is needed. When the fluid is let into the first chamber part, the gas inside the second chamber part is compressed, increasing the volume of the first chamber part as it is filled with fluid.

**[0040]** The capacity of the chamber is typically 5 litres, preferably 8 litres or more preferably 10 litres, or more.

**[0041]** The control device 11 may also comprise a motor adjusting the control device or the position of the valve in order to let more or less fluid into the first chamber, or even stop the fluid from entering.

**[0042]** By having a flow channel connecting the chamber with the cavity, the chamber can be arranged at a distance from the tubular part of the blowout preventer and is easily implemented in existing blowout preventers. Furthermore, the control device 11 can be mounted on the flow channel so that the control device can be operated by an ROV, or manually or even remotely.

**[0043]** The blowout preventer 1 may further comprise a control unit comprising the storage device, and/or a communication unit for communicating with the control device. The blowout preventer 1 may further comprise a sensor for sensing a pressure in the cavity and the current pressure can be sent through the communication unit or stored for later use. Depending on the pressure, the control device is actuated to either let more fluid into the first chamber part 8 or decrease the flow thereto.

**[0044]** Fig. 2 shows a well intervention tool 100 for pulling the plug 37, such as a crown plug, in a top part 23 of a well head 2 in order to be able to enter the well. The intervention tool 100 comprises a connection pulling unit 50, such as a GS pulling tool having a connection unit 51 matching the connection of the plug 37. When performing a pulling operation, the intervention tool 100 is arranged in a lubricator connected to the top of the blowout preventer 1. The intervention tool 100 comprises a fixation unit 54 for fixating the stroking tool 52 in relation to the well head 2 so that the axial movement of the stroking tool 52 pulls the plug 37 out of the well head 2. The fixation unit 54 comprises an anchoring section having anchors moving radially from the tool towards an inside wall of the lubricator 20 as shown in Fig. 2. In another embodiment, the fixation unit 54 comprises a tubular section surrounding part of the connection pulling tool for abutting the top part 23 of the well head 2 as shown in Fig. 3.

**[0045]** The stroking 52 tool comprises a tool housing in which a pressure reducing system in the form of a chamber 106 and a piston is arranged. The piston 107 is arranged in a sliding manner on a shaft 112 inside the chamber, dividing the chamber into a first chamber part 108 and a second chamber part 109. The first chamber part 108 is in fluid communication with an opening 113 in the tool housing 52 and thus in fluid communication with fluid in the lubricator. The second chamber part 109 is filled with a compressible fluid, such as gas. In order to reduce the amount of force needed to pull a plug 37, the pressure inside the lubricator is reduced after the lubricator has been connected with the well head 2. The stroking tool 52 further comprises a control device 111, such as a valve, for controlling the pressure in the lubricator by controlling the amount of fluid let into the first chamber part 108. By letting fluid from the lubricator into the first chamber part 108, the piston moves and the gas in the second chamber part 109 is compressed and the pressure inside the lubricator is reduced. By reducing the pressure in the lubricator, the amount of force needed to pull the plug is also reduced substantially, and thus the anchoring force needed is reduced accordingly. By reducing the anchoring force, a standard lubricator can be used to anchor up and the plug can thus be pulled by a stroking tool.

**[0046]** As shown in Fig. 2, the connection of the plug 37 to be pulled comprises a female connection and the connection unit of the connection pulling unit 50 is shaped as a male connection with latches matching the female connection. The intervention tool 100 further comprises a stroking tool 52 connected to the connection pulling unit and providing an axial movement along the axial extension for moving the male connection unit into engagement with the female connection of the plug 37. Once the male-shaped connection unit 51 engages the female connection of the plug, the stroking tool moves a first part of the connection pulling unit 50 in relation to a second part in order to move the latches radially outwards.

**[0047]** As can be seen, the control device 112 is arranged in the opening 111, but may be arranged in any suitable manner.

**[0048]** The stroking tool 52 is connected with the connection pulling unit 50 by means of a stoker shaft 55 and a threaded connection or a conventional male/female connection.

**[0049]** The blowout preventer 1 may comprise a control unit comprising a storage device, and a communication unit for communicating with the control device. In this way, the control device 11 can be controlled from surface.

**[0050]** Fig. 2 further shows a well intervention system 200 comprising any conventional blowout preventer or the blowout preventer mentioned above and a lubricator 20 connectable to the blowout preventer in which the intervention tool 100 is arranged in order to pull the plug 37. Normally, the intervention tool needs to pull two plugs which may be done in two runs. A second intervention tool inside a second lubricator may be arranged in the

vicinity of the well head, ready to be connected when the first plug is pulled.

**[0051]** The intervention system may comprise a disconnection unit arranged between a lubricator valve and the blowout preventer for disconnecting a part of the system, such as for disconnecting the lubricator and the intervention tool arranged inside the lubricator.

**[0052]** The intervention tool may further comprise a driving section, such as a downhole tractor, in order to anchor the tool inside the lubricator. Due to a pressure reducing system 120, the intervention tool needs not be anchored as much as prior art tools. The intervention tool 100 may be wireless and driven only by an internal power source, such as a battery.

**[0053]** The blowout preventer 1 may often be arranged in a supporting structure in the form of a frame structure, and together with the frame structure it forms an intervention module. Furthermore, the blowout preventer 1 comprising a control device on its outside enables a diver or the Remote Operational Vehicle (also called an ROV) to read and/or operate the control device in order to let fluid into the first chamber part 8, 108.

**[0054]** The control device may comprise a receiving and/or transmitting unit so that the control device has data transmission capability to a remote operating centre. The remote operating centre may thus be located in the nearest town and still be able to control a park of wells, and thus well heads 2, without viewing the control device. The blowout preventer 1 may also comprise a control unit comprising a receiving and/or transmitting unit enabling the control unit to transmit data to and from a remote operating centre. Communicating with and receiving and/or transmitting data to and from the remote operating centre may take place by means of a satellite.

**[0055]** A motor, such as an electrical motor, may be arranged to operate the control device.

**[0056]** A stroking tool is a tool providing an axial force. The stroking tool comprises an electrical motor for driving a pump. The pump pumps fluid into a piston housing to move a piston acting therein. The piston is arranged on the stoker shaft 55.

**[0057]** The pump may pump fluid into the piston housing on one side and simultaneously suck fluid out on the other side of the piston.

**[0058]** By fluid or well fluid is meant any kind of fluid that may be present in oil or gas wells downhole, such as natural gas, oil, oil mud, crude oil, water, etc. By gas is meant any kind of gas composition present in a well, completion, or open hole, and by oil is meant any kind of oil composition, such as crude oil, an oil-containing fluid, etc. Gas, oil, and water fluids may thus all comprise other elements or substances than gas, oil, and/or water, respectively.

**[0059]** By a casing is meant any kind of pipe, tubing, tubular, liner, string etc. used downhole in relation to oil or natural gas production.

**[0060]** In the event that the tool is not submergible all the way into the casing, a downhole tractor can be used

to push the tool all the way into position in the well. A downhole tractor is any kind of driving tool capable of pushing or pulling tools in a well downhole, such as a Well Tractor®.

5 **[0061]** Although the invention has been described in the above in connection with preferred embodiments of the invention, it will be evident for a person skilled in the art that several modifications are conceivable without departing from the invention as defined by the following claims.  
10

## Claims

- 15 **1.** A blowout preventer (1) for being mounted on a well head (2), comprising:
- a plurality of valves (3, 4) arranged in fluid communication with each other, connected and forming a tubular pipe (5) enclosing a cavity (10) being in fluid communication with the well head when the blowout preventer is mounted onto the well head and at least one plug 37 in the well head has been removed, wherein the blowout preventer further comprises a chamber (6) and a piston (7) arranged inside the chamber dividing the chamber into a first chamber part (8) and a second chamber part (9), the first chamber part being in fluid communication with the cavity and the second chamber part being filled with a compressible fluid, such as gas.
- 20
- 25 **2.** A blowout preventer according to claim 1, wherein the cavity has a first pressure and the blowout preventer further comprises a control device (11), such as a valve, for controlling the pressure in the cavity by letting fluid in the cavity into the first chamber part.
- 30
- 35 **3.** A blowout preventer according to claim 1 or 2, wherein the piston is slidably arranged on a shaft (12) arranged inside the chamber.
- 40
- 45 **4.** A blowout preventer according to any of the preceding claims, wherein the chamber is connected with the cavity by means of a flow channel (15).
- 50 **5.** A blowout preventer according to any of the preceding claims, further comprising a control unit (38) comprising a storage device, and a communication unit for communicating with the control device.
- 55 **6.** A blowout preventer according to any of the preceding claims, further comprising a sensor for sensing a pressure in the cavity.
- 7.** A well intervention tool (100) intended to be arranged in a lubricator for pulling a plug (37) in a top part (23) of a well head (2) of a well for entering the well, the

well head having an axial extension, comprising:

- a connection pulling unit (50) having a connection unit (51) for connection to the plug,
  - a stroking tool (52) having a tool housing (53) and being connected to the connection pulling unit and providing an axial movement along the axial extension,
  - a fixation unit (54) for fixating the stroking tool in relation to the well head so that the axial movement of the stroking tool pulls the plug out of the well head, wherein the stroking tool comprises a chamber (106) and a piston (107) arranged inside the chamber dividing the chamber into a first chamber part (108) and a second chamber part (109), the first chamber part being in fluid communication with an opening (113) in the tool housing and the second chamber part being filled with a compressible fluid, such as gas.
8. A well intervention tool (100) according to claim 7, wherein the stroking tool further comprises a control device (11), such as a valve, for letting fluid in through the opening of the housing into the first chamber part.
9. A well intervention tool (100) according to claim 7 or 8 wherein the connection pulling unit is a GS pulling tool.
10. A well intervention tool (100) according to any of the claims 7-9, wherein the piston is slidably arranged on a shaft (112) arranged inside the chamber.
11. A well intervention tool (100) according to any of the claims 7-10, wherein the control device is arranged in the opening.
12. A well intervention tool (100) according to any of the claims 7-11, wherein the stroking tool is connected with the connection pulling unit by means of a stroker shaft (55).
13. A well intervention tool (100) according to any of the claims 7-12, wherein the fixating unit comprises an anchoring section having anchors moving radially from the tool towards an inside wall of the lubricator.
14. A well intervention system (200) comprising:
- a blowout preventer according to any of claims 1-6 for connection onto a well head,
  - a lubricator (20) connectable to the blowout preventer, and
  - an intervention tool (100) according to any of claims 7-13 arranged inside the lubricator.

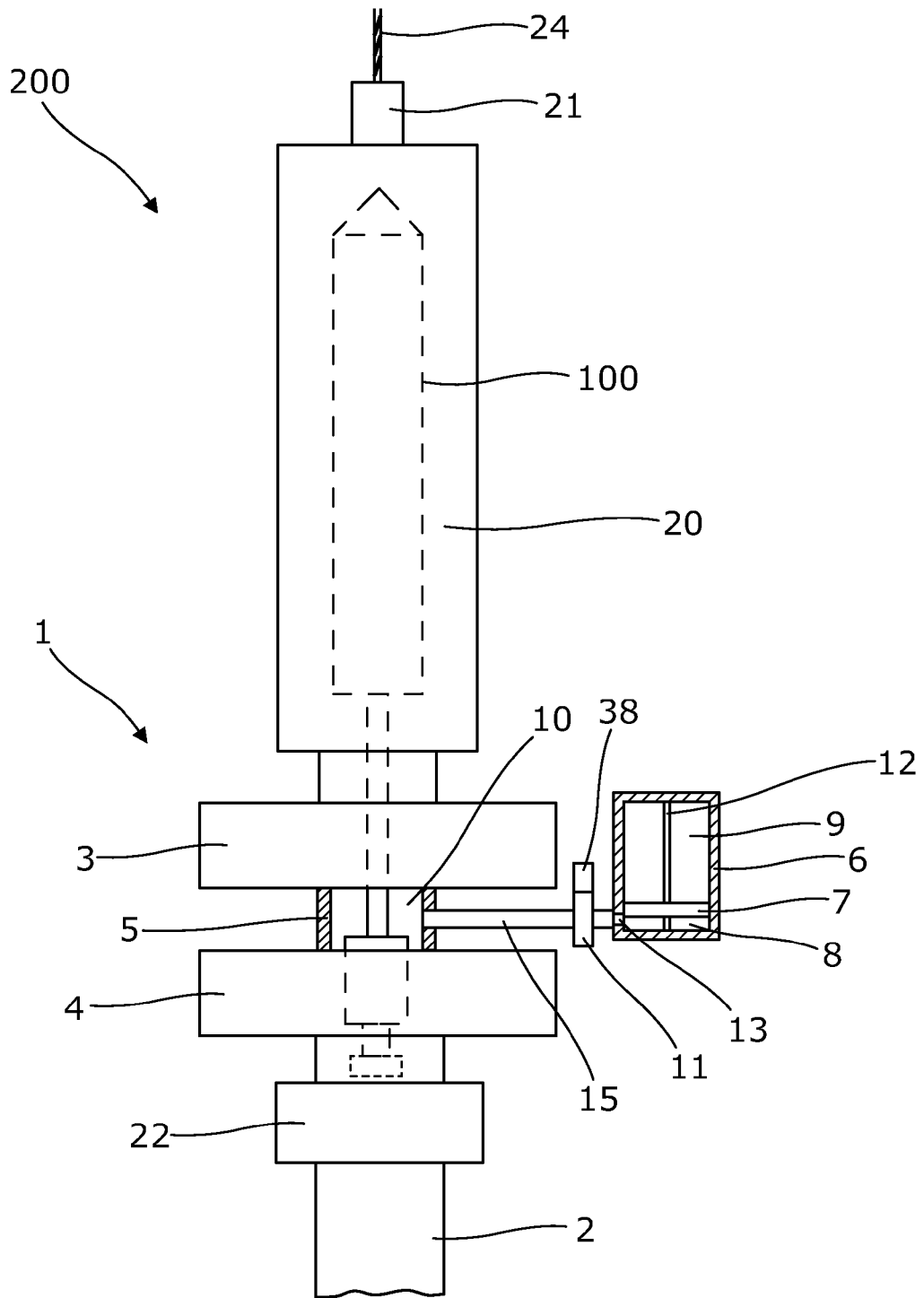

Fig. 1

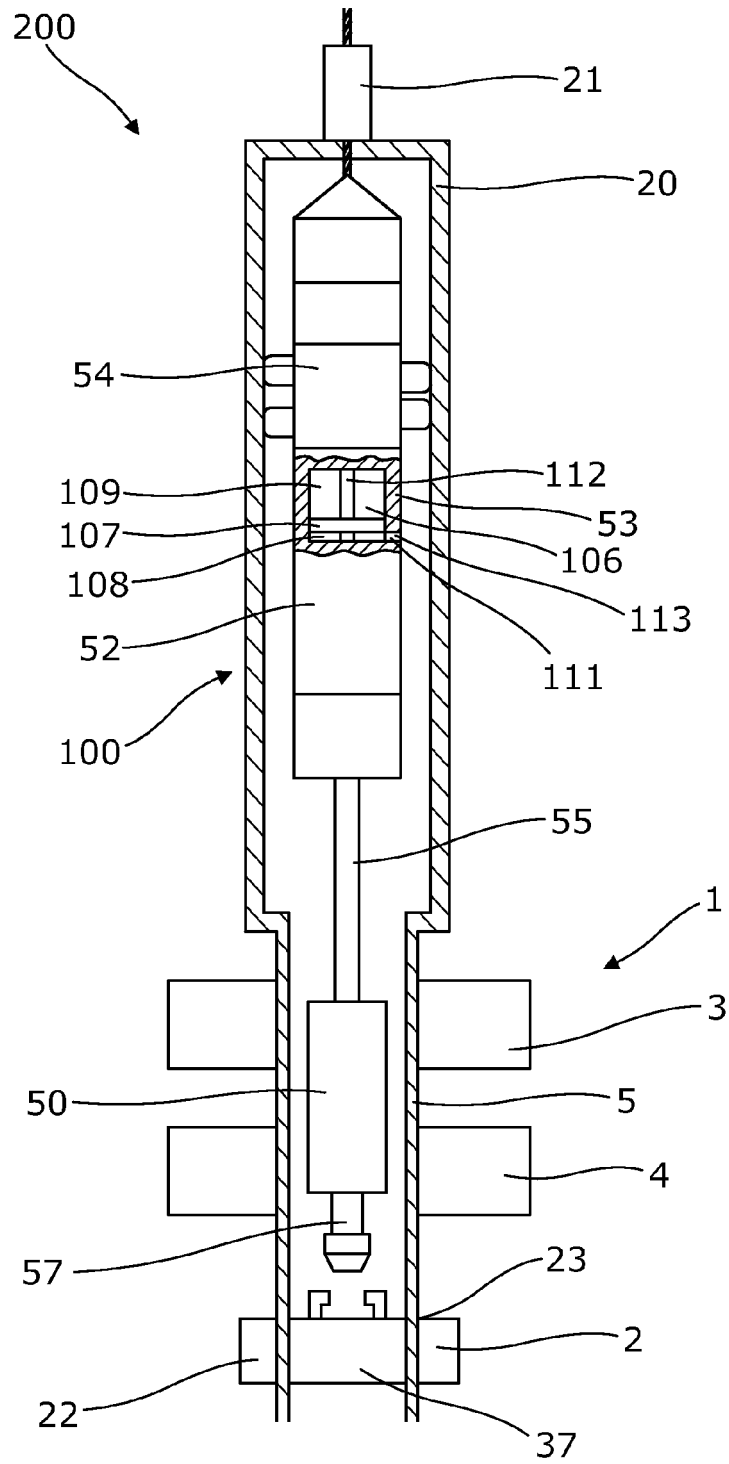

Fig. 2

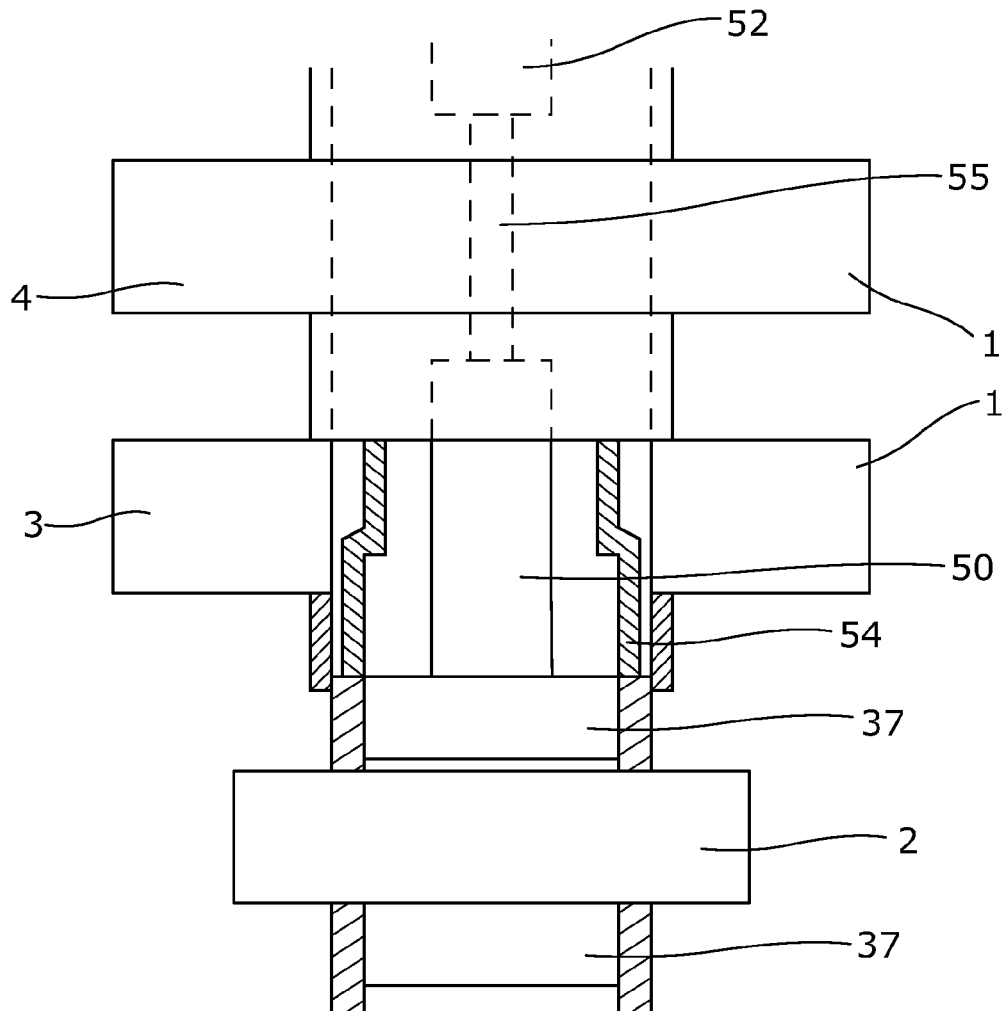

Fig. 3



EUROPEAN SEARCH REPORT

Application Number  
EP 11 17 2161

| DOCUMENTS CONSIDERED TO BE RELEVANT  |   |   |   |
|--|---|---|---|
| Category   | Citation of document with indication, where appropriate, of relevant passages   | Relevant to claim   | CLASSIFICATION OF THE APPLICATION (IPC) |
| A  | WO 2010/019378 A2 (SCHLUMBERGER TECHNOLOGY CORP [US]; SCHLUMBERGER TECHNOLOGY BV [NL]; SC) 18 February 2010 (2010-02-18)<br>* page 4, paragraph 15 - page 8, paragraph 36; figure 1 * | 1,7   | INV.<br>E21B33/064<br>E21B33/076        |
| A  | WO 2009/056842 A2 (EXPRO NORTH SEA LTD [GB]; PATTILLO SCOTT [GB]; DERRICK ROBIN [GB] EXPR) 7 May 2009 (2009-05-07)<br>* abstract; figure 2 *  | 1,7   |   |
| A  | WO 2010/065993 A1 (WELL OPS SEA PTY LTD [AU]; JONES ROBERT WILLIAM [AU]; WALKER BRETT MIT) 17 June 2010 (2010-06-17)<br>* the whole document *  | 1,7   |   |
|  |   |   | TECHNICAL FIELDS SEARCHED (IPC)         |
|  |   |   | E21B                                    |
| The present search report has been drawn up for all claims   |   |   |   |
| Place of search<br>Munich  |   | Date of completion of the search<br>5 December 2011   | Examiner<br>Ott, Stéphane               |
| CATEGORY OF CITED DOCUMENTS<br>X : particularly relevant if taken alone<br>Y : particularly relevant if combined with another document of the same category<br>A : technological background<br>O : non-written disclosure<br>P : intermediate document |   | T : theory or principle underlying the invention<br>E : earlier patent document, but published on, or after the filing date<br>D : document cited in the application<br>L : document cited for other reasons<br>.....<br>& : member of the same patent family, corresponding document |   |

1  
EPO FORM 1508 03 82 (P04C01)

**ANNEX TO THE EUROPEAN SEARCH REPORT  
ON EUROPEAN PATENT APPLICATION NO.**

EP 11 17 2161

This annex lists the patent family members relating to the patent documents cited in the above-mentioned European search report. The members are as contained in the European Patent Office EDP file on  
The European Patent Office is in no way liable for these particulars which are merely given for the purpose of information.

05-12-2011

| Patent document cited in search report | Publication date | Patent family member(s)  | Publication date                                     |
|--|------------------|--|--|
| WO 2010019378 A2                       | 18-02-2010       | US 2010040999 A1<br>WO 2010019378 A2                                   | 18-02-2010<br>18-02-2010                             |
| WO 2009056842 A2                       | 07-05-2009       | CA 2704477 A1<br>EP 2205822 A2<br>US 2010288510 A1<br>WO 2009056842 A2 | 07-05-2009<br>14-07-2010<br>18-11-2010<br>07-05-2009 |
| WO 2010065993 A1                       | 17-06-2010       | NONE   |  |

EPO FORM P0459

For more details about this annex : see Official Journal of the European Patent Office, No. 12/82