

(19)



(11)

**EP 2 551 226 A3**

(12)

**EUROPEAN PATENT APPLICATION**

(88) Date of publication A3:  
**25.12.2013 Bulletin 2013/52**

(51) Int Cl.:  
**B65H 54/20** (2006.01) **B65H 65/00** (2006.01)  
**D02G 1/02** (2006.01)

(43) Date of publication A2:  
**30.01.2013 Bulletin 2013/05**

(21) Application number: **12177601.7**

(22) Date of filing: **24.07.2012**

(84) Designated Contracting States:  
**AL AT BE BG CH CY CZ DE DK EE ES FI FR GB GR HR HU IE IS IT LI LT LU LV MC MK MT NL NO PL PT RO RS SE SI SK SM TR**  
Designated Extension States:  
**BA ME**

(72) Inventors:  
• **Yamamoto, Masato**  
**Kyoto, 612-8686 (JP)**  
• **Yamato, Manabu**  
**Kyoto, 612-8686 (JP)**

(30) Priority: **26.07.2011 JP 2011163356**

(74) Representative: **HOFFMANN EITL**  
**Patent- und Rechtsanwälte**  
**Arabellastrasse 4**  
**81925 München (DE)**

(71) Applicant: **TMT Machinery, Inc.**  
**Osaka-shi, Osaka 541-0041 (JP)**

(54) **Yarn winder**

(57) A winding device capable of forming two packages P by winding yarns Ya and Yb onto respective two take up tubes 19B supported by a single cradle 20 is provided with two automatic yarn threading devices 24a and 24b. Each of the automatic yarn threading devices 24a and 24b has components such as a suction mouth 51, a yarn moving mechanism 52, a yarn providing arm 53, a yarn supporting arm 54, and a yarn pressing arm 55. The yarn providing arm 53 is swung about a shaft 65

which is in parallel to the axis of the take up tube 19B so as to cause the yarn Ya (Yb) to oppose the take up tube 19B. The yarn pressing arm 55 is swung about a shaft 66 which is in parallel to the shaft 65 so as to cause the yarn Ya (Yb) positioned by the yarn providing arm 53 to closely contact the outer circumference of the take up tube 19B. The yarn supporting arm 54 supports the yarn Ya (Yb) by sandwiching the yarn with the yarn pressing arm 55.

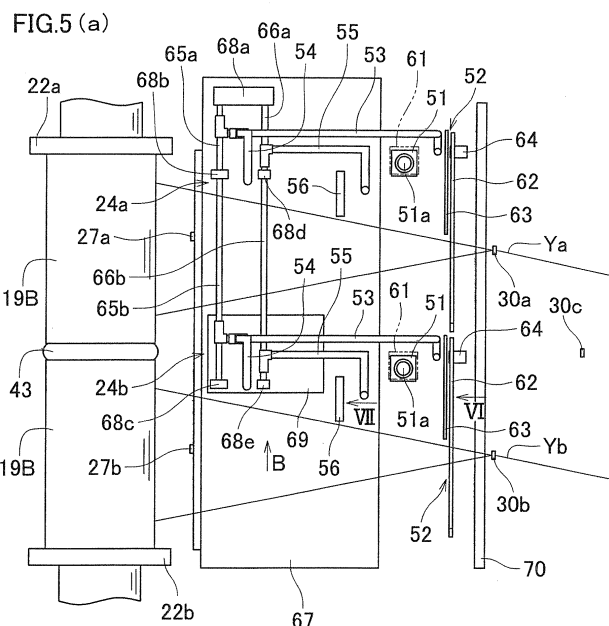

**EP 2 551 226 A3**



EUROPEAN SEARCH REPORT

Application Number  
EP 12 17 7601

DOCUMENTS CONSIDERED TO BE RELEVANT			
Category	Citation of document with indication, where appropriate, of relevant passages	Relevant to claim	CLASSIFICATION OF THE APPLICATION (IPC)
X	US 4 023 741 A (SCHAR HUGO) 17 May 1977 (1977-05-17)	1,4	INV. B65H54/20 B65H65/00 D02G1/02
Y	* column 2, line 46 - column 4, line 29; figures *	4	
Y	----- DE 10 2008 038343 A1 (TMT MACHINERY INC [JP]) 5 March 2009 (2009-03-05)	1,2,4-8	
A	* paragraphs [0046] - [0048]; figures *	3	
Y	----- DE 43 15 257 A1 (MURATA MACHINERY LTD [JP]) 11 November 1993 (1993-11-11)	1,2,5,6	
Y	* column 6, lines 30-61; figures *	7,8	
Y	----- DE 10 2005 053830 A1 (SAURER GMBH & CO KG [DE]) 16 May 2007 (2007-05-16)	7,8	
			TECHNICAL FIELDS SEARCHED (IPC)
			B65H D02G
The present search report has been drawn up for all claims			
Place of search		Date of completion of the search	Examiner
The Hague		19 November 2013	Lemmen, René
CATEGORY OF CITED DOCUMENTS		T : theory or principle underlying the invention E : earlier patent document, but published on, or after the filing date D : document cited in the application L : document cited for other reasons ..... & : member of the same patent family, corresponding document	
X : particularly relevant if taken alone Y : particularly relevant if combined with another document of the same category A : technological background O : non-written disclosure P : intermediate document			

1  
EPO FORM 1503.03.82 (P04C01)

ANNEX TO THE EUROPEAN SEARCH REPORT  
ON EUROPEAN PATENT APPLICATION NO.

EP 12 17 7601

This annex lists the patent family members relating to the patent documents cited in the above-mentioned European search report.  
The members are as contained in the European Patent Office EDP file on  
The European Patent Office is in no way liable for these particulars which are merely given for the purpose of information.

19-11-2013

Patent document cited in search report	Publication date	Patent family member(s)	Publication date
US 4023741 A	17-05-1977	BE 835081 A1	30-04-1976
		CH 587767 A5	13-05-1977
		DE 2551290 A1	20-05-1976
		FR 2291141 A1	11-06-1976
		GB 1533101 A	22-11-1978
		IT 1048062 B	20-11-1980
		JP S5172656 A	23-06-1976
		JP S5924059 B2	06-06-1984
		NL 7511997 A	18-05-1976
		US 4023741 A	17-05-1977
-----			
DE 102008038343 A1	05-03-2009	NONE	
-----			
DE 4315257 A1	11-11-1993	DE 4315257 A1	11-11-1993
		IT 1261473 B	23-05-1996
		JP 3161034 B2	25-04-2001
		JP H05311529 A	22-11-1993
		US 5363637 A	15-11-1994
-----			
DE 102005053830 A1	16-05-2007	NONE	
-----			

EPO FORM P0459

For more details about this annex : see Official Journal of the European Patent Office, No. 12/82