



(11) **EP 2 572 028 B1**

(12) **EUROPEAN PATENT SPECIFICATION**

(45) Date of publication and mention of the grant of the patent:

**01.04.2015 Bulletin 2015/14**

(21) Application number: **11718366.5**

(22) Date of filing: **05.05.2011**

(51) Int Cl.:

**D06F 58/20<sup>(2006.01)</sup>**

(86) International application number:

**PCT/EP2011/057188**

(87) International publication number:

**WO 2011/144453 (24.11.2011 Gazette 2011/47)**

(54) **LAUNDRY DRIER WITH A STEAM GENERATOR**

WÄSCHETROCKNER MIT DAMPFGENERATOR

SECHE LINGE AYANT UN GENERATEUR DE VAPEUR

(84) Designated Contracting States:

**AL AT BE BG CH CY CZ DE DK EE ES FI FR GB GR HR HU IE IS IT LI LT LU LV MC MK MT NL NO PL PT RO RS SE SI SK SM TR**

(30) Priority: **17.05.2010 EP 10163020**

(43) Date of publication of application:

**27.03.2013 Bulletin 2013/13**

(73) Proprietor: **BSH Hausgeräte GmbH**

**81739 München (DE)**

(72) Inventors:

- **SALON, Artur**  
**97-400 Belchatow (PL)**
- **TRYBULA, Michal**  
**93-516 Lodz (PL)**

(56) References cited:

**EP-A1- 2 145 998 FR-A1- 2 929 961**  
**GB-A- 638 019 US-A- 3 159 174**

**EP 2 572 028 B1**

Note: Within nine months of the publication of the mention of the grant of the European patent in the European Patent Bulletin, any person may give notice to the European Patent Office of opposition to that patent, in accordance with the Implementing Regulations. Notice of opposition shall not be deemed to have been filed until the opposition fee has been paid. (Art. 99(1) European Patent Convention).

## Description

**[0001]** The invention relates to a laundry appliance comprising a steam generator wherein the steam generator comprises a water tank, wherein the water tank is fluidically connected to a filling means and a de-aeration means, and wherein a highest point of the de-aeration means is located higher than the filling means.

**[0002]** Such laundry appliance and embodied as a steam iron is apparent from GB 638 019 A.

**[0003]** U. S. Patent 3,180,037 relates to a laundry appliance embodied as a clothes dryer comprising a means for dispersing a fabric treating material into said hot air in said flow passage substantially at said surface to effect a concurrent drying and treatment of fabrics in said chamber.

**[0004]** U. S. Patent 3,242,584 relates to a laundry appliance embodied as a domestic clothes drying device providing the combination of a rotatable drum for tumbling damp fabric, means for producing superheated steam, means for passing a predetermined amount of said superheated steam interiorly of said drum for vaporizing the liquid contained in the fabric tumbled by said drum, means for circulating air through said drum for extracting steam and vaporized liquid therefrom, and means for heating the air circulating through said drum for providing a final drying cycle supplementing that produced by said superheated steam.

**[0005]** U. S. Patent 4,207,683 relates to a laundry dryer having a touch-up spray for removal of wrinkles from clothing and fabrics and permanent press clothing, in particular without removing possibly present factory set creases. The dryer may include a water heating unit for spraying water of a selected temperature or steam. The steam is applied to remove undesired wrinkles or odours from the laundry being treated and thus provides refreshment to the laundry. Accordingly, this dryer may be designated to be a "refresher dryer". It should be remarked that such nomination is not reserved to an appliance which is designed merely to dry laundry besides the refreshing function; instead, it will also be applied to a washer/dryer with a refreshing function.

**[0006]** DE 34 08 136 A1 relates to a tumble dryer comprising a venturi-type mixing tube which is fed with steam via a gas feeding pipe and water via an inlet. In the venturi-type mixing tube water is atomized due to the effect of the steam coming out of a nozzle, whereby a mist consisting of steam and water with extremely fine droplets is created. This mixture is sprayed into an inside of a drum as a mist cloud. Thus, textile material can be moistened and subsequently dried.

**[0007]** EP 1 275 767 A1 relates to a laundry appliance embodied as a clothes dryer or washer/dryer that treats laundry by introducing steam into a tub after the drainage of water to reduce creases. Steam treatment water is held in the tub at a temperature of at least 40 °C and at most 70 °C. There can be a heater to heat the water in the tub and produce the steam.

**[0008]** EP 1 655 408 A1 relates to a device to generate steam in a laundry appliance which is a washing machine, said device comprising a main body and means of heating the main body, wherein a flow channel is defined in the main body such that water flowing through the flow channel is heated and converted to steam.

**[0009]** GB 638 019 A discloses a steam iron having a soleplate and a heel and which is adapted to be stood in an ironing position in which the iron rests on the soleplate and in an upended position in which the iron rests on its heel, the iron including a steam-generator carried in the soleplate, means for heating the soleplate and generator, a reservoir for storing water to be converted into steam in the generator, an orifice for discharging water from the reservoir to the generator, an adjustable valve operatively associated with the orifice for regulating the flow of water therethrough, the orifice being spaced from the nose portion of the reservoir a distance substantially equal to one-half the length of the soleplate, there being an opening through which water may be introduced into the reservoir, the opening and reservoir being so constructed and related that the reservoir may be filled to substantially its complete capacity, and a closed conduit extending along the bottom of the reservoir from the orifice to the vicinity of the extreme nose of the reservoir and having the end thereof near the nose of the reservoir open, so that, when the iron is in its ironing position, the water in the reservoir will enter the open end of and will flow through the conduit to the orifice, and when the iron is upended, the open end of the conduit will be above the level of the water in the reservoir even when the latter is filled substantially to its complete capacity.

**[0010]** It is an object of the present invention to provide a particularly maintenance-friendly and safe operation of a steam generator for a laundry appliance.

**[0011]** The object is achieved according to the features of the independent claim. Preferred embodiments can be derived, inter alia, from the dependent claims as well as from the following specification.

**[0012]** The object of the invention is achieved by a laundry appliance comprising a steam generator, wherein

- the steam generator comprises a water tank wherein the water tank is fluidically connected to a filling means and a de-aeration means, and wherein
- a highest point of the de-aeration means is located higher than the filling means; wherein further
- the laundry appliance is a refresher dryer;
- the filling means comprises a filling hose and the de-aeration means comprises a de-aeration hose;
- the filling hose comprises a lower end that is connected to the water tank of the steam generator and an upper end that is intended to be filled with water,
- the de-aeration hose comprises a lower end that is connected to the water tank of the steam generator and an upper end that is fluidically connected to air; wherein
- the highest point of the de-aeration hose is located

- higher than the upper end of the filling hose; and
- the de-aeration hose comprises at least an upside-down U-shaped section.

**[0013]** The invention including this steam generator has the advantage that, since the highest point of the de-aeration hose is located higher than the upper end of the filling hose, a spill-over of the water tank can readily be avoided. Thus, when the steam generator is filled, then water will be visible to a user at the upper end of the filling hose. In this case the de-aeration hose is still not filled up to the top such that no spill-over of water from the de-aeration hose occurs. Also, because of the upside-down U-shaped section of the de-aeration hose, there is no possibility to accidentally fill the steam generator with water being introduced into the upper end of the de-aeration hose (e.g. coming from a condensate container shell). Both measures support a low-maintenance and safe operation.

**[0014]** It is a preferred embodiment that a tip of the 'U' corresponds to the highest point of the de-aeration hose. This achieves a particular safe prevention of accidentally filling the steam generator via the de-aeration hose. Also, a presence of water remains within the de-aeration hose that may house germs or the like can be prevented easily.

**[0015]** It is another preferred embodiment that the upper end of the de-aeration hose is connected to an overfall hose. This further reduces the possibility of water entering the de-aeration hose from its upper end since the overfall hose quickly guides water flowing through it (e.g. from the condensate container shell) into a bottom section of the laundry appliance or directly into a drain. A filling of the overfall hose with water is highly unlikely.

**[0016]** It is yet another preferred embodiment that an upper end of the overfall hose is connected to a condensate container shell. The overfall hose can thus prevent a spilling of water from the condensate container shell which might else harm operation or cause extra maintenance of the laundry appliance.

**[0017]** It is still another preferred embodiment that the lower end of the de-aeration hose and / or of the filling hose is connected to the steam generator by a rubber connector. This enables a leak-proof, cost-effective and thermally robust connection.

**[0018]** It is also a preferred embodiment that the upper end of the filling hose is connected to an inlet funnel. The inlet funnel facilitates filling the filling hose by a user, e.g. with distilled water, and provides an easy means to detect a full filling hose or water level.

**[0019]** It is even another preferred embodiment that the de-aeration hose is a corrugated hose at least in sections. This facilitates a compact and versatile design avoiding the danger of fatigue cracks in or buckling of the de-aeration hose.

**[0020]** It is yet another preferred embodiment that the U-shaped section of the de-aeration hose is not a corrugated section. This ensures a safe seat of the U-shaped section, e.g. a conformal support, by preventing slipping

from the support.

**[0021]** It is a further preferred embodiment that the highest point of the de-aeration hose is located at least 2 cm, in particular at least 5 cm, higher than the upper end of the filling hose. This prevents a water flow into the overfall hose even if the laundry appliance is set up obliquely. Preferably, the level B is at least 2 cm higher than level A plus a (lowest) height of the inlet funnel such that a user may also fill the inlet funnel without an adverse effect. This improves detection of a water level, in particular when filling up the water tank. Preferably, the highest point of the de-aeration hose is at least about 5 cm higher than the upper end of the filling hose plus/and the (lowest) height of the inlet funnel.

**[0022]** In the following description which in particular refers to the figures of the attached drawing, a preferred embodiment of the invention is schematically described in greater detail. In the drawing,

- Fig.1 shows an oblique view onto a laundry appliance comprising a steam generator;
- Fig.2 shows an oblique view onto the steam generator of the laundry appliance of Fig.1;
- Fig.3 shows an exploded view of the steam generator;
- Fig.4 shows an oblique view onto a cut-out of a laundry appliance according to another embodiment; and
- Fig.5 shows an enlarged cut-out of the laundry appliance according the another embodiment.

**[0023]** Fig.1 shows a refresher dryer 1 that is a clothes dryer that incorporates a clothes or laundry refreshing and de-wrinkling function applying steam to the clothes. The refresher dryer 1 is shown without housing. In particular, the refresher dryer 1 is embodied as a tumble dryer comprising a rotatable drum 2 which holds the clothes to be dried and which may be operated by being rotated in reversing rotational directions. The drum 2 can be loaded and unloaded through an opening 3. The opening 3 is typically closed by a door (not shown). The operation of a tumble dryer 1 as such is well known.

**[0024]** To implement the refreshing function, the refresher dryer 1 comprises a steam generator 4 which is located at a bottom of the refresher dryer 1 and mounted on top of a cover 39 of a heat exchanger 40. Of the steam generator 4, a front side F (see also fig.2) is visible. The steam generator 4 is used to generate steam from water. The water (preferably distilled water) is supplied to the steam generator 4 via a filling hose 6 which comprises a lower end 49 that is connected to a water inlet 19 of the steam generator 4 (as described in greater detail in fig. 2) and an upper end 50 that is intended to be filled with distillate water via an inlet funnel 51.

**[0025]** The output generated by the steam generator 4 usually is a mixture of steam and hot water and is led to a steam separator 7. The steam separator 7 separates the steam from the hot water. The steam is fed into the drum 2 via a hose 8 that leads to a nozzle 9. The nozzle

9 opens into the drum 2 and may inject the steam directly onto the laundry to be treated therein. The steam injection may comprise an injection of steam and/or a fine mist of water droplets. To this end, the nozzle 9 may have a shape (e.g. angular shape) that allows orientation of the steam flow. The hot water is returned to a T-connector 42 located in a dryer pump reservoir via a flexible hot water return hose. Thus, the steam separator 7 ensures that only steam with a low or very low liquid content is fed into the drum 2.

**[0026]** The steam generator 4 further comprises or is connected to a basically straight de-aeration hose 43. This de-aeration hose 43 comprises a lower end 52 that is connected to the water tank 10 of the steam generator 4 via a de-aeration outlet 44 (see fig.3) by a rubber connector 60 and an upper end 53 is fluidically connected to air by being connected to an upper region of a condensate container shell 5.

**[0027]** The steam generator 4 further comprises a siphon fixation 47 for holding or fixing a siphon 48.

**[0028]** Fig.2 shows the steam generator 4 in greater detail by showing an elevated view onto a rear side B of the steam generator 4. The rear side B of the steam generator 4 borders on the drum 2 and faces to the inside of the refresher dryer 1 of Fig.1. The front side F of the steam generator 4 is shown in Fig.1.

**[0029]** The steam generator 4 comprises a water tank 10 for a base that is covered by an upper part 11 of a tank body of the water tank 10. A water level of the water tank 10 is measured by a water level sensor 12 that is implemented as a combined reed water level sensor 12a and float water level sensor 12b. The water level sensor 12 is placed inside the water tank 10. The water tank 10 is filled with water via the water inlet 19 that is connected to the filling hose 6 as shown in fig.1. The water level sensor 12 may be used to control the function of the steam generator 4 as well as the function of drying components of the refresher dryer 1; in this case the water tank 10 also acts as a water tank for the drying components.

**[0030]** On top of the upper part 11 of the water tank 10 a heater 13 is mounted to heat water and subsequently produce steam, usually mixed with the hot water. The heater 13 comprises an aluminum housing and is supported on support columns 21. Further, the support columns 21 each hold a respective silicone holder 23 laterally mounted to the heater 13. This holding or supporting arrangement of the heater 13 has the advantage that vibrations from or to the heater 13 are suppressed and that a thermal flow from the heater 13 is at least partially blocked by the silicone holders 23. The heater 13 is not arranged horizontally but is angled relative to the horizontal in order to achieve an improved de-calcification.

**[0031]** The mixture of steam and hot water generated within the heater 13 is led out of the heater 13 and fed to the steam separator 7 by a steam outlet pipe 15 or hose. A temperature of the heater 13 is monitored by a NTC (negative temperature coefficient) sensor 16 that is

mounted on top / on an upper part of the heater 13. The NTC sensor 16 may be regarded as part of the heater 13.

**[0032]** The heater 13 also comprises or is connected to a safety switch 17 by which the heater 13 may be switched off to prevent overheating.

**[0033]** The water is supplied from the water tank 10 to the heater 13 by a water pump 14 which is implemented as a solenoid-driven vibration pump. The solenoid pump 14 is supported by a pair of screwed rubber holders 18. This reduces the propagation of vibration and thus reduces the overall noise of the steam generator. The suppression of the vibration propagation also enhances the life time of the steam generator 4.

**[0034]** Fig.3 shows an exploded view of the steam generator 4 viewing its front side F. The water tank 10 comprises a tank body 20, which is covered by the upper part 11. The upper part 11 comprises the water inlet 19 for connection with the lower end 49 of the filling hose 6 and the de-aeration outlet 44 for connection with the lower end 52 of the de-aeration hose 43. The tank body 20 comprises a water outlet 45 that can be connected to a water inlet of the water pump 14 via a water pipe 46. At a bottom of the tank body 20 there is placed a metal insert 25 that acts as a barrier against fire in the unlikely case of a melting of the heater 13. The bottom of the tank body 20 also holds the siphon fixation 47.

**[0035]** The upper surface of the water tank 10 further comprises the support columns 21 for supporting the heater 13. To this end, the support columns 21 each comprise an upper recess 22 for supporting the respective silicone holder 23. Each silicone holder 23 is in turn laterally mounted to the heater 13, in particular fitted onto a respective mounting column 24. This holding arrangement of the heater 13 has the advantage that vibrations from or to the heater 13 are suppressed and that a thermal flow from the heater 13 is at least partially blocked by the silicone holders 23.

**[0036]** Water is supplied into the heater 13 via a water inlet connection 27, is guided within the heater 13 by a water tube 38 and can then leave the heater 13 as steam or a mixture of hot water and steam by a steam outlet connection 28. The water tube 38 can be heated up by a heating element or heating elements (not visible) of the heater 13. The water tube 38 is located on a top surface of the heater 13. The water inlet connection 27 is connected to a pressure outlet 29 of the water pump 14 by a connection hose 30. The water inlet connection 27 and the pressure outlet 29 are aligned horizontally and facing each other; this ensures a direct / linear connection that acts against a possible pressure drop at the heater 13 and that also prevents the hose 30 from coming off. The steam outlet connection 28 is connected to the steam outlet pipe 15. The heater 13 is angled relative to the horizontal with the end comprising the connections 27, 28 being placed lower than the opposite end in order to achieve an improved de-calcification.

**[0037]** Between the upper part 11 of the water tank 10 and the heater 13 there is inserted a metal insert 25 with

soft edges, e.g. round edges. The soft edges prevent damage to electrical connections, e.g. damage to an insulation of an electrical cable. The heater 13 is grounded electrically via the metal insert 25 and from the metal insert 25 further to a dryer frame 33 shown in Fig.1. The metal insert 25 may act as a barrier against fire in the unlikely case of a melting of the heater 13.

**[0038]** On top of the heater 13 the NTC sensor 16 is mounted. Electrical terminals 26 of a heating element of the heater 13 are located at the same side as the water inlet and outlet.

**[0039]** At the bottom of the heater 13 the safety switch 17 is located. The safety switch 17 uses a duo pack comprising a bi-metal element and a fuse to prevent overheating of the heater 13. In case that the safety switch 17 detects an overheating condition, it switches off the heater 13. Threshold temperatures where a switching action will occur are presently set at 190°C for the bi-metal element which is reversible, and 260°C for the fuse which is irreversible. Thereby, the safety switch 17 will turn off the heater 13 reversibly in case of a minor malfunction which produces a temperature rise of minor criticality, and it will turn off the heater 13 irreversibly (that is, irreversibly except by action of a skilled service technician) upon a temperature rise of major criticality. It is understood that problems of less criticality include problems caused by temporary clogs of and water bubbles in the water hoses leading to the heater 13 which may be expected to disappear by themselves and do not require attention by a skilled service technician. Accordingly, it is understood to be a sufficient measure to interrupt the action of the heater 13 only reversibly upon encountering such problems. The safety switch 17 may be located near the heating element(s), or the heating element(s) may at least partially be inserted into the safety switch 17.

**[0040]** The steam outlet pipe 15 and the connection hose 30 are placed above and may be borne on a micanite safety insert 31. The safety insert 31 provides a leakage protection. Furthermore, the safety insert 31 prevents electrical connections from getting in contact with water that may be leaking or condensing at the or between the water pump 14 and the heater 13. The use of micanite or mica provides for a high dielectric strength, excellent chemical stability, and high resistance to excess heat. Also, the plate-like micanite safety insert 31 is light-transmissive such that it does not inhibit a view onto elements located below it.

**[0041]** The steam generator 4 further comprises a single connection housing 32 for all electrical connections / internal wiring 41. The connection housing 32 may be produced, e.g. by AMP Inc. All electrical connections lead into the connection housing 32. The electrical connections / internal wiring 41 include an earth connection line 34 and an electrical connection 35 being connected to a temperature protector 36 of the water pump 14. The temperature protector 36 is mounted on the water pump 14. The connection housing 32 may be connected to a cover 37 of the steam generator 4 by clamping.

**[0042]** The steam generator 4 is in large parts covered by a plastic cover 37. The plastic cover 37 can be clamped onto the tank 10 without the need for screws or other additional fixing elements to provide easy assembly. The plastic cover 37 can be made of a flame retardant material, like a V0 material, to ensure standards for safety regulations.

**[0043]** Fig.4 shows an oblique view of a cut-out of a laundry appliance 54 according to another embodiment. Fig.5 shows an enlarged cut-out of the laundry appliance 54. The laundry appliance 54 is similar to the laundry appliance 1 except that the de-aeration hose 55 is formed differently. The de-aeration hose 55 still comprises the lower end 52 that is connected to the steam generator 4 via the de-aeration outlet 44 and an upper end 56 that is fluidically connected to air.

**[0044]** The upper end 56 of the de-aeration hose 55 is connected to an overfall hose 58. An upper end of the overfall hose 58 is connected to the condensate container shell 5 while its lower end may be connected to a bottom part of the laundry appliance 54 or a drain. The overfall hose 58 may thus prevent filling up and spilling of the condensate container shell 5. Connecting the upper end 56 of the de-aeration hose 55 to the overfall hose 58 gives the advantage that a flow of water from into the de-aeration hose 55 is unlikely. This advantage is emphasized by the fact that the de-aeration hose 55 now comprises an upside-down U-shaped section 57, a tip 59 of which corresponds to the highest point of the de-aeration hose 55. Thus, water from the overfall hose 58 would have to travel upwards first if it would enter the de-aeration hose 55 which ensures that there is no spilling of water through the de-aeration hose 55 into the water tank 10.

**[0045]** In particular, the tip 59 of the U-shaped section 57 is located higher (on a level B) within the laundry appliance 54 than the upper end 50 of the filling hose 6 (which is on a lower level A). Thus, by virtue of the principle of communicating vessels, water will also not spill out of the de-aeration hose 55 into the overfall hose 58 which prevents an unintentional waste of water and, if a user does not realize that the filling hose 6 is filled, a flooding of the laundry appliance 54. Rather, a user can detect a filled filling hose 6 by seeing the (preferably distilled) water being near or coming out of the upper end 50. Preferably, the level B is at least 2 cm higher than level A to prevent a water flow into the overfall hose 58 even if the laundry appliance 54 is set up obliquely. Preferably, the level B is at least 5 cm higher than level A. Preferably, the level B is at least 2 cm higher than level A plus a (lowest) height of the inlet funnel 51 such that a user may also fill the inlet funnel 51 without an adverse effect. This improves detection of a water level, in particular when filling up the water tank 10. Preferably, level B is at least about 2 cm to 5 cm higher than the level A plus the height of the inlet funnel 51.

**[0046]** To shape and mount the de-aeration hose 55 easily without introducing mechanically overstressed or

compressed regions, it is embodied as a corrugated hose at least in sections. The corrugated sections are shown graphically. The U-shaped section 57 of the de-aeration hose 55, on the other hand, is not a corrugated section to certainly maintain its U-shape and to prevent slipping from its support. The de-aeration hose 55 and / or the filling hose 6 may be made of plastic and / or of metal, e.g. stainless steel (being a pipe at least in parts).

#### List of Reference Numerals

##### [0047]

1	refresher dryer
2	drum
3	opening
4	steam generator
5	condensate container shell
6	filling hose
7	steam separator
8	hose
9	nozzle
10	water tank
11	upper part of tank body
12	water level sensor
12a	reed sensor
12b	float sensor
13	heater
14	water pump
15	steam outlet pipe
16	NTC sensor
17	safety switch
18	rubber holder
19	water inlet
20	tank body
21	support column
22	upper recess
23	silicone holder
24	mounting column
25	metal insert
26	electrical terminal
27	water inlet connection
28	steam outlet connection
29	pressure outlet
30	connection hose
31	safety insert
32	housing
33	dryer frame
34	earth connection line
35	electrical connection
36	temperature protector
37	plastic cover
38	water tube
39	cover of heat exchanger
40	heat exchanger
41	internal wiring
42	T-connector
43	de-aeration hose

44	de-aeration outlet
45	water outlet
46	water pipe
47	siphon fixation
5	48 siphon
49	lower end of the filling hose
50	upper end of the filling hose
51	inlet funnel
52	lower end of the de-aeration hose
10	53 upper end of the de-aeration hose
54	laundry appliance
55	de-aeration hose
56	upper end of the de-aeration hose
57	U-shaped section of the de-aeration hose
15	58 overfall hose
59	tip of the U-shaped section
A	level A
B	level B
R	rear side of steam generator
20	F front side of steam generator

#### Claims

- 25 1. A laundry appliance (54) comprising a steam generator (4), wherein
- 30 - the steam generator (4) comprises a water tank (10) wherein the water tank (10) is fluidically connected to a filling means and a de-aeration means, and wherein
- a highest point of the de-aeration means is located higher than the filling means;
- characterized in that**
- 35 - the laundry appliance (54) is a refresher dryer (54);
- the filling means comprises a filling hose (6) and the de-aeration means comprises a de-aeration hose (43);
- 40 - the filling hose (6) comprises a lower end (49) that is connected to the water tank (10) of the steam generator (4) and an upper end (50) that is intended to be filled with water;
- the de-aeration hose (43) comprises a lower end that is connected to the water tank (10) of the steam generator (4) and an upper end that is fluidically connected to air, wherein
- the highest point of the de-aeration hose (43) is located higher than the upper end (50) of the filling hose (6); and
- 50 - the de-aeration hose (43) comprises at least an upside-down U-shaped section (57).
- 55 2. The laundry appliance (54) according to claim 1, wherein a tip of the U-shaped section (57) corresponds to the highest point of the de-aeration hose (55).

3. The laundry appliance (54) according to any of the previous claims, wherein the highest point of the de-aeration hose (43) is located at least 2 cm higher than the upper end (50) of the filling hose (6). 5
4. The laundry appliance (54) according to any of the previous claims, wherein the upper end (56) of the de-aeration hose (55) is connected to an overfall hose (58). 10
5. The laundry appliance (54) according claim 4, wherein an upper end of the overfall hose (58) is connected to a condensate container shell (5).
6. The laundry appliance (54) according to any of the previous claims, wherein the lower end (52) of the de-aeration hose (55) is connected to the steam generator (4) by a rubber connector (60). 15
7. The laundry appliance (54) according to any of the previous claims, wherein the upper end (50) of the filling hose (6) is connected to an inlet funnel (51). 20
8. The laundry appliance (54) according to claim 7, wherein the highest point of the de-aeration hose (43) is located at least 2 cm higher than the upper end (50) of the filling hose (6) and the height of the inlet funnel (51). 25
9. The laundry appliance (54) according to any of the previous claims, wherein the de-aeration hose (55) comprises at least one corrugated section. 30
10. The laundry appliance (54) according claim 9, wherein the at least one U-shaped section (57) of the de-aeration hose (55) is not a corrugated section. 35

#### Patentansprüche

1. Haushaltsgerät (54) für die Wäsche mit einem Dampferzeuger (4), bei dem
- der Dampferzeuger (4) einen Wasserbehälter (10) umfasst, der mit einem Füllmittel und einem Entlüftungsmittel fluidverbunden ist, und
  - ein höchster Punkt des Entlüftungsmittels höher liegt als das Füllmittel,
- dadurch gekennzeichnet, dass**
- es sich bei dem Haushaltsgerät (54) für die Wäsche um einen Auffrisch-Trockner (54) handelt,
  - das Füllmittel einen Füllschlauch (6) und das Entlüftungsmittel einen Entlüftungsschlauch (43) umfasst,
  - der Füllschlauch (6) ein unteres Ende (49), das mit dem Wasserbehälter (10) des Dampferzeugers (4) verbunden ist, und ein oberes Ende (50)
- umfasst, das mit Wasser gefüllt werden soll,
- der Entlüftungsschlauch (43) ein unteres Ende, das mit dem Wasserbehälter (10) des Dampferzeugers (4) verbunden ist, und ein oberes Ende umfasst, das mit Luft fluidverbunden ist, wobei
  - der höchste Punkt des Entlüftungsschlauchs (43) höher liegt als das obere Ende (50) des Füllschlauchs (6) und
  - der Entlüftungsschlauch (43) zumindest einen umgekehrt U-förmigen Abschnitt (57) umfasst.
2. Haushaltsgerät (54) für die Wäsche nach Anspruch 1, bei dem eine Spitze des U-förmigen Abschnitts (57) dem höchsten Punkt des Entlüftungsschlauchs (55) entspricht.
3. Haushaltsgerät (54) für die Wäsche nach einem der vorhergehenden Ansprüche, bei dem der höchste Punkt des Entlüftungsschlauchs (43) mindestens 2 cm höher liegt als das obere Ende (50) des Füllschlauchs (6).
4. Haushaltsgerät (54) für die Wäsche nach einem der vorhergehenden Ansprüche, bei dem das obere Ende (56) des Entlüftungsschlauchs (55) mit einem Überlaufschlauch (58) verbunden ist.
5. Haushaltsgerät (54) für die Wäsche nach Anspruch 4, bei dem ein oberes Ende des Überlaufschlauchs (58) mit einer Kondensatbehälterschale (5) verbunden ist.
6. Haushaltsgerät (54) für die Wäsche nach einem der vorhergehenden Ansprüche, bei dem das untere Ende (52) des Entlüftungsschlauchs (55) über ein Verbindungsstück (60) aus Gummi mit dem Dampferzeuger (4) verbunden ist.
7. Haushaltsgerät (54) für die Wäsche nach einem der vorhergehenden Ansprüche, bei dem das obere Ende (50) des Füllschlauchs (6) mit einem Einlauftrichter (51) verbunden ist.
8. Haushaltsgerät (54) für die Wäsche nach Anspruch 7, bei dem der höchste Punkt des Entlüftungsschlauchs (43) mindestens 2 cm höher liegt als das obere Ende (50) des Füllschlauchs (6) und die Höhe des Einlauftrichters (51).
9. Haushaltsgerät (54) für die Wäsche nach einem der vorhergehenden Ansprüche, bei dem der Entlüftungsschlauch (55) mindestens einen gewellten Abschnitt umfasst.
10. Haushaltsgerät (54) für die Wäsche nach Anspruch 9, bei dem es sich bei dem mindestens einen U-förmigen Abschnitt (57) des Entlüftungsschlauchs

(55) nicht um einen gewellten Abschnitt handelt.

## Revendications

1. Appareil de laverie (54) comprenant un générateur de vapeur (4), dans lequel
  - le générateur de vapeur (4) comprend un réservoir d'eau (10), dans lequel le réservoir d'eau (10) est connecté fluidiquement avec un moyen de remplissage et un moyen de désaération, et dans lequel
  - un point le plus élevé du moyen de désaération est situé plus haut que le moyen de remplissage ;
  - caractérisé en ce que**
  - l'appareil de laverie (54) est un sècheur-rafraîchisseur (54) ;
  - le moyen de remplissage comprend un tuyau (6) de remplissage et le moyen de désaération comprend un tuyau (43) de désaération ;
  - le tuyau (6) de remplissage comprend une extrémité inférieure (49) qui est connectée au réservoir d'eau (10) du générateur de vapeur (4) et une extrémité supérieure (50) qui est destinée à être remplie d'eau ;
  - le tuyau (43) de désaération comprend une extrémité inférieure qui est connectée au réservoir d'eau (10) du générateur de vapeur (4) et une extrémité supérieure qui est connectée fluidiquement à l'air ; dans lequel
  - le point le plus élevé du tuyau (43) de désaération est situé plus haut que l'extrémité supérieure (50) du tuyau (6) de remplissage ; et
  - le tuyau (43) de désaération comprend au moins une section (57) en forme de U inversé.
2. Appareil de laverie (54) selon la revendication 1, dans lequel une pointe de la section (57) en forme de U correspond au point le plus élevé du tuyau (55) de désaération.
3. Appareil de laverie (54) selon l'une quelconque des revendications précédentes, dans lequel le point le plus élevé du tuyau (43) de désaération est situé au moins 2 cm plus haut que l'extrémité supérieure (50) du tuyau (6) de remplissage.
4. Appareil de laverie (54) selon l'une quelconque des revendications précédentes, dans lequel l'extrémité supérieure (56) du tuyau (55) de désaération est connecté à un tuyau (58) d'évacuateur.
5. Appareil de laverie (54) selon la revendication 4, dans lequel une extrémité supérieure du tuyau (58) d'évacuateur est connecté à une enveloppe (5) de récipient de condensat.
6. Appareil de laverie (54) selon l'une quelconque des revendications précédentes, dans lequel l'extrémité inférieure (52) du tuyau (55) de désaération est connectée au générateur de vapeur (4) par un connecteur (60) en caoutchouc.
7. Appareil de laverie (54) selon l'une quelconque des revendications précédentes, dans lequel l'extrémité supérieure (50) du tuyau (6) de remplissage est connectée à un entonnoir (51) d'entrée.
8. Appareil de laverie (54) selon la revendication 7, dans lequel le point le plus élevé du tuyau (43) de désaération est situé au moins 2 cm plus haut que l'extrémité supérieure (50) du tuyau (6) de remplissage et que la hauteur de l'entonnoir (51) d'entrée.
9. Appareil de laverie (54) selon l'une quelconque des revendications précédentes, dans lequel le tuyau (55) de désaération comprend au moins une section cannelée.
10. Appareil de laverie (54) selon la revendication 9, dans lequel l'au moins une section (57) en forme de U du tuyau (55) de désaération n'est pas une section cannelée.

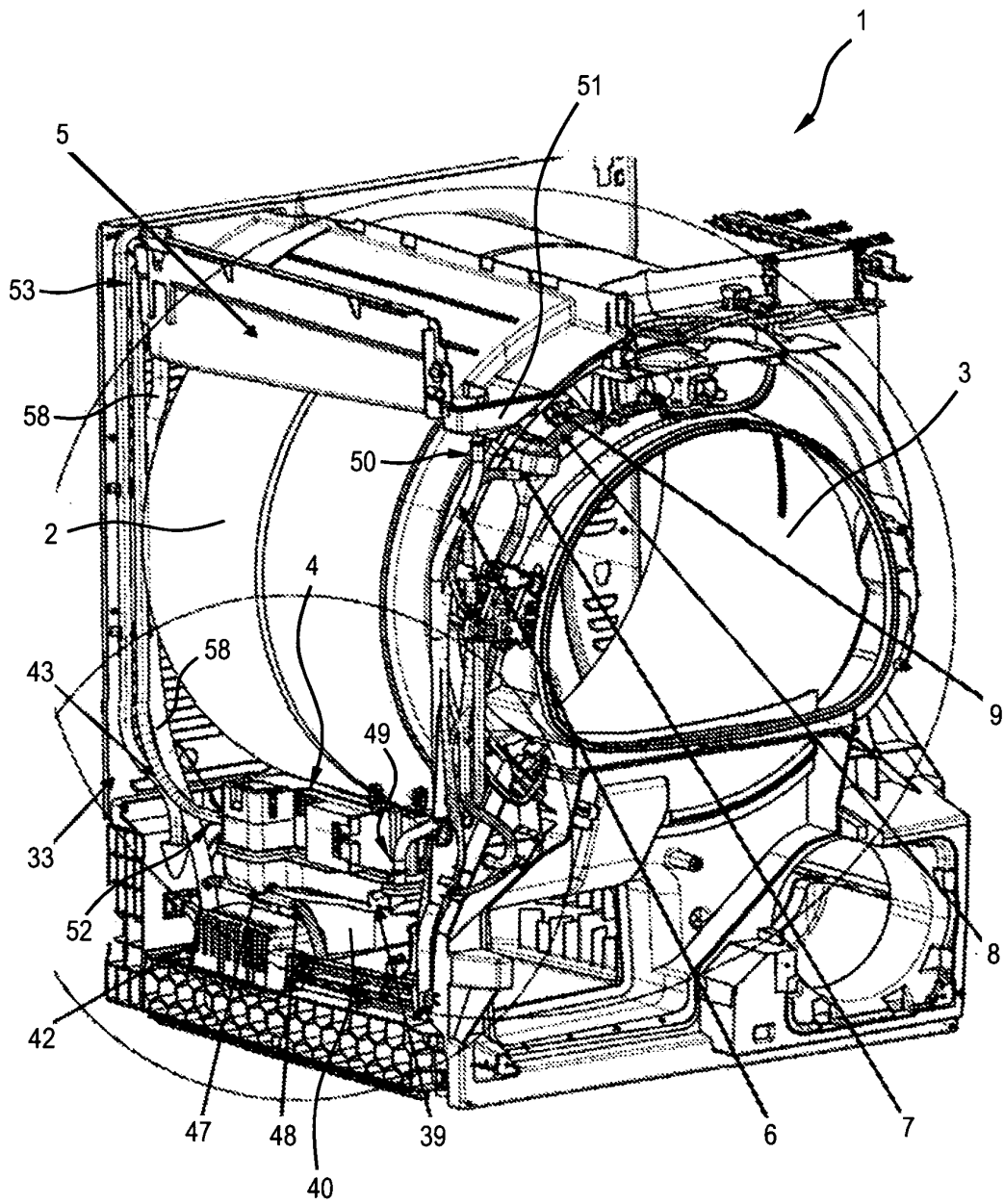

Fig. 1

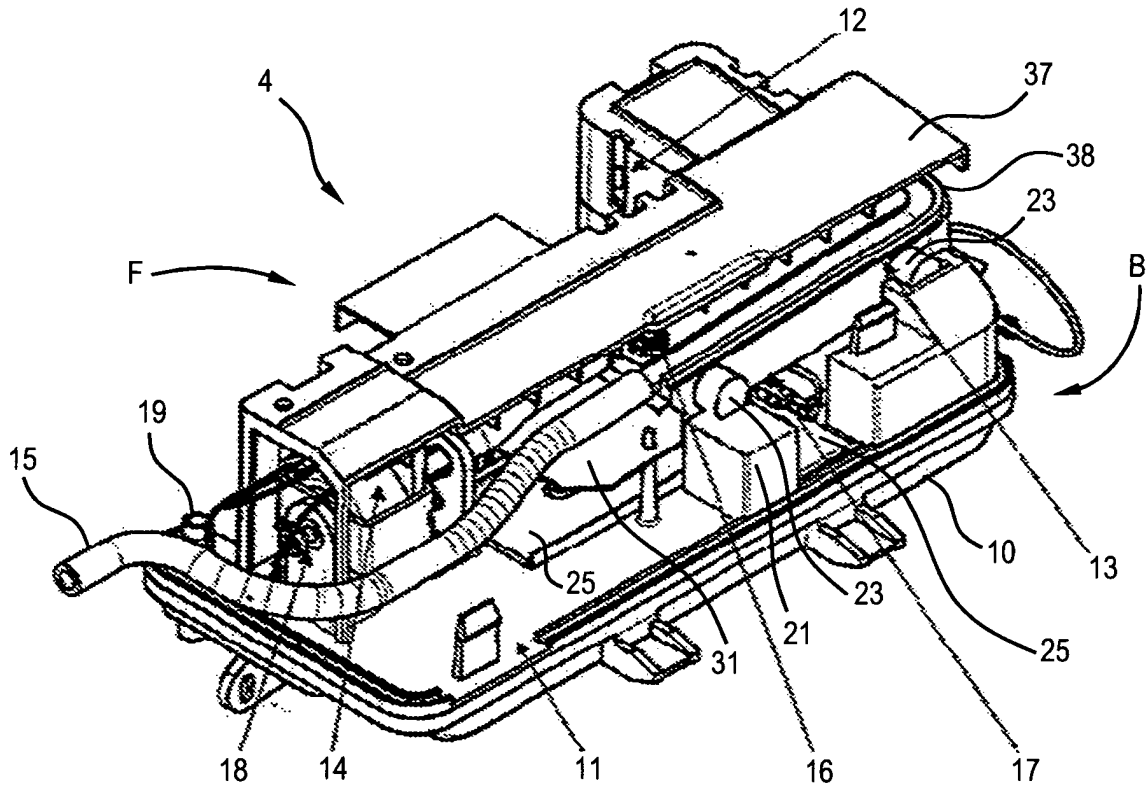

Fig. 2

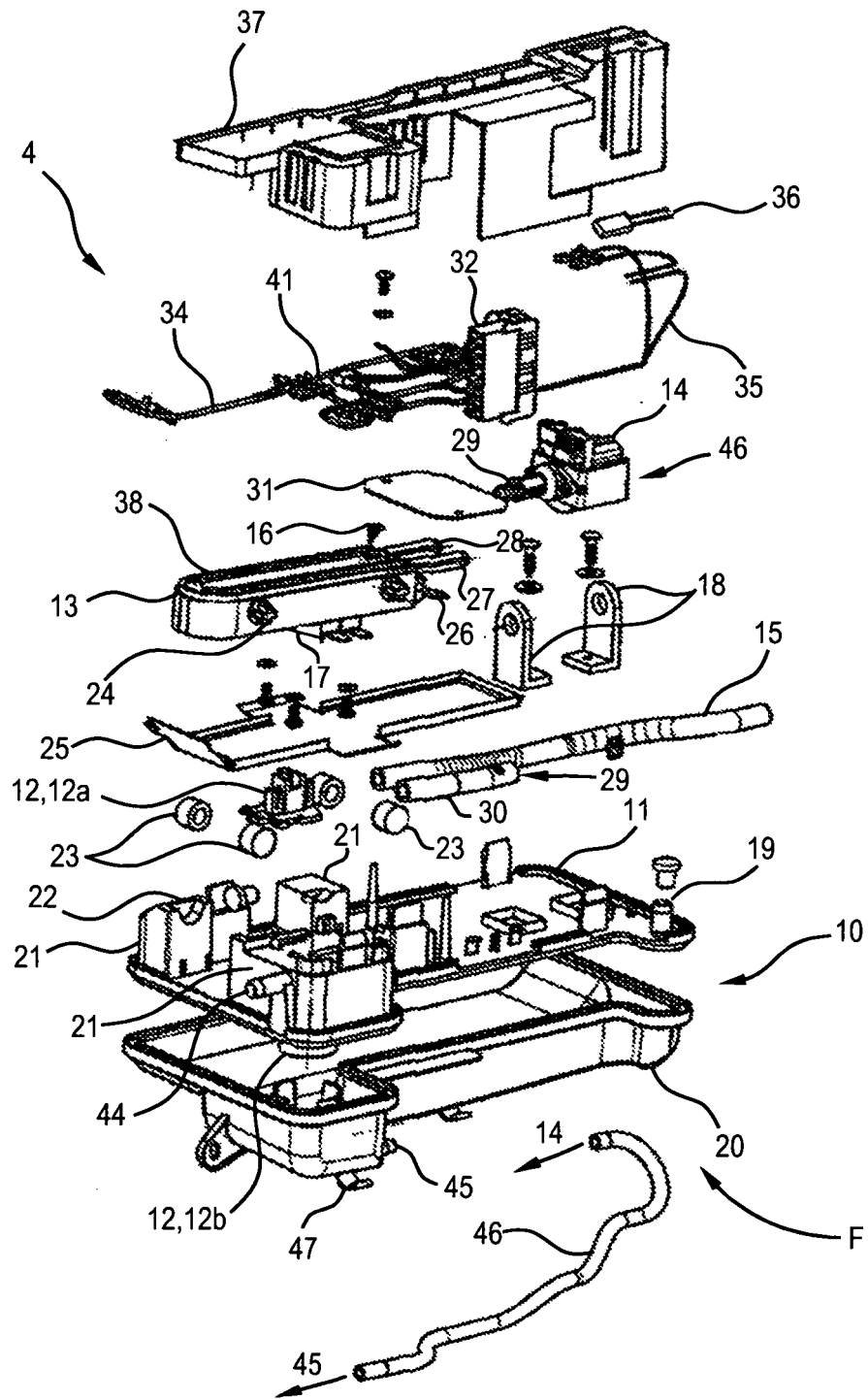

Fig. 3

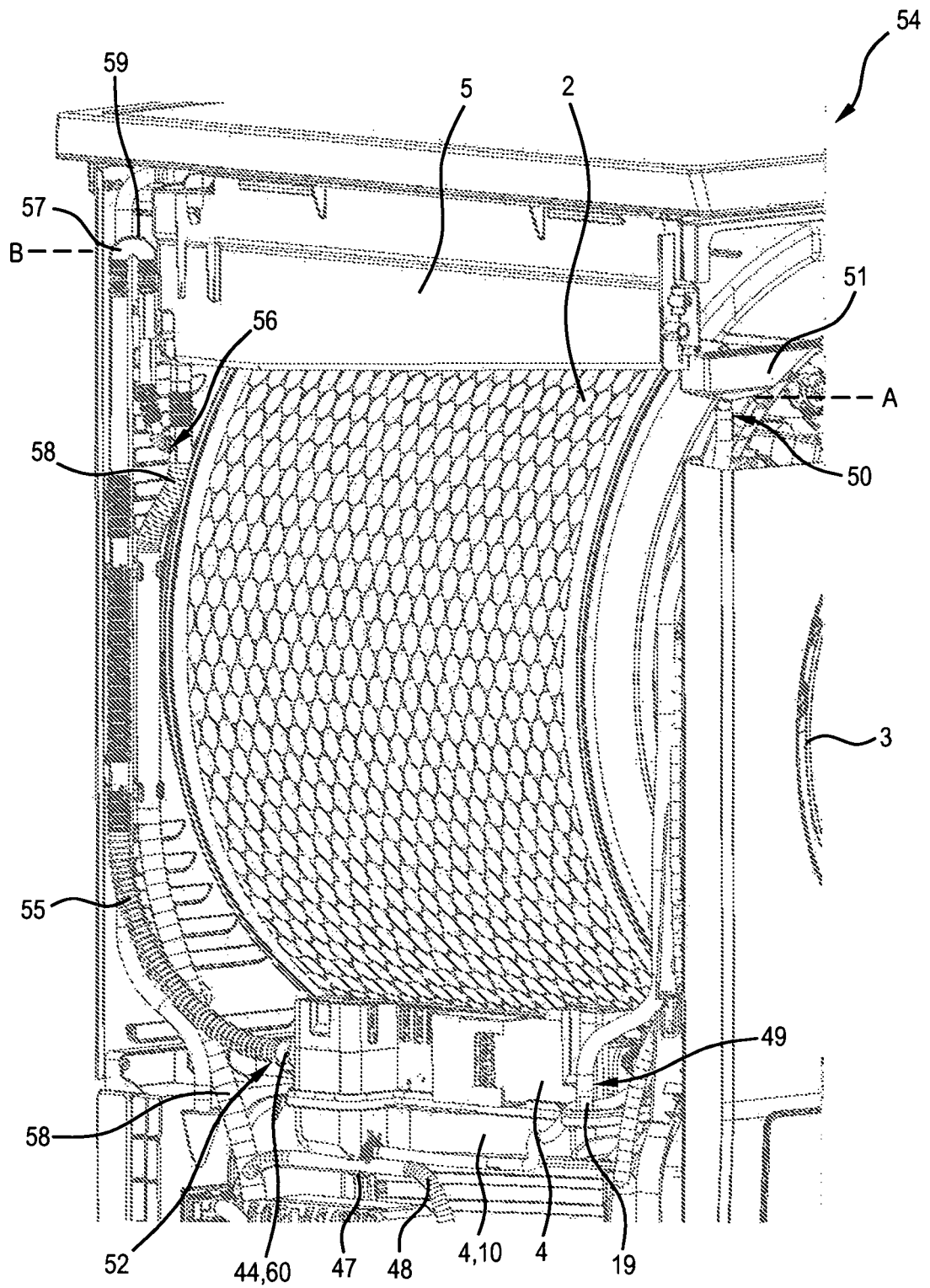

Fig. 4

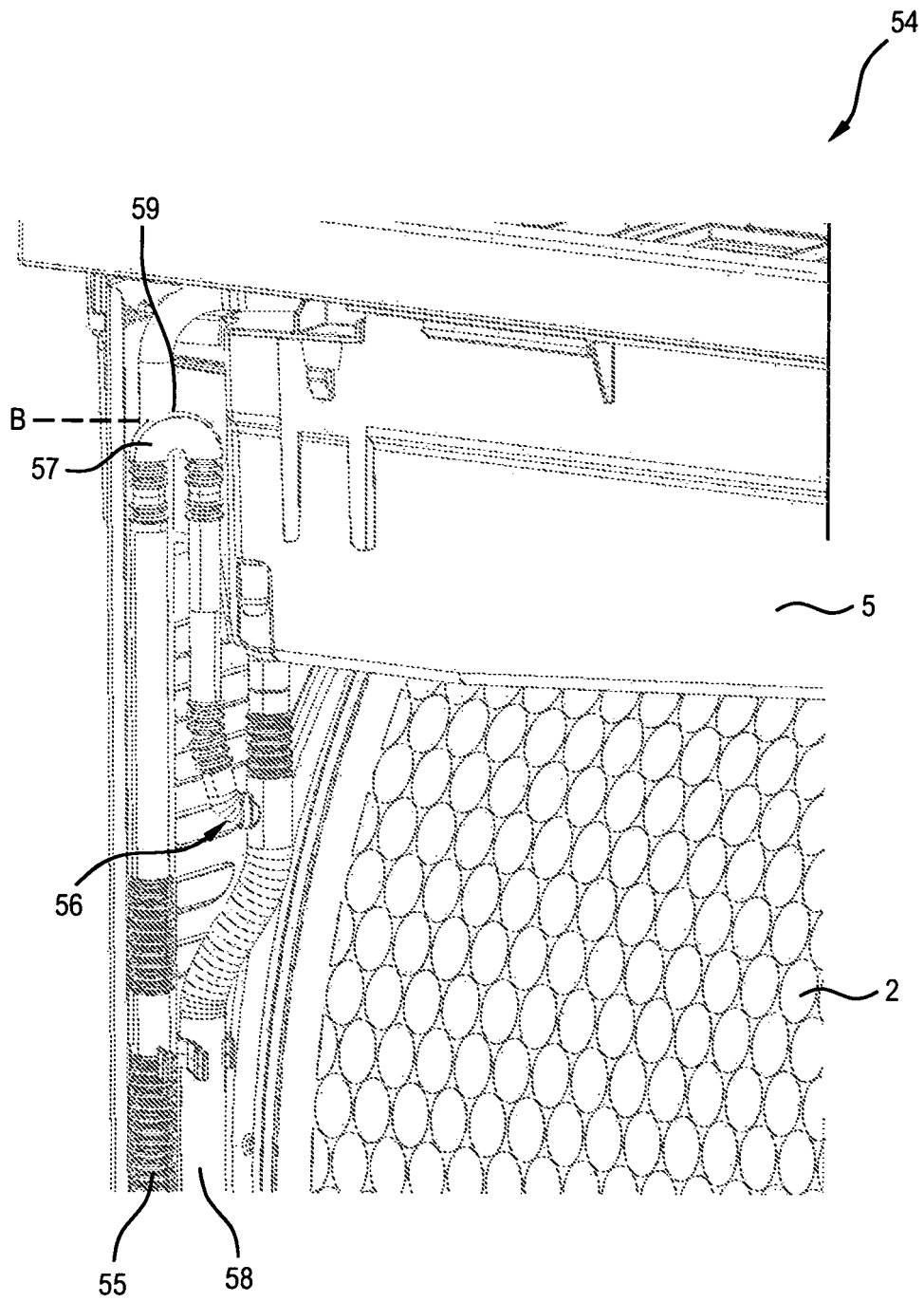

Fig. 5

**REFERENCES CITED IN THE DESCRIPTION**

*This list of references cited by the applicant is for the reader's convenience only. It does not form part of the European patent document. Even though great care has been taken in compiling the references, errors or omissions cannot be excluded and the EPO disclaims all liability in this regard.*

**Patent documents cited in the description**

- GB 638019 A [0002] [0009]
- US 3180037 A [0003]
- US 3242584 A [0004]
- US 4207683 A [0005]
- DE 3408136 A1 [0006]
- EP 1275767 A1 [0007]
- EP 1655408 A1 [0008]