

(19)



(11)

EP 2 613 656 B1

(12)

EUROPEAN PATENT SPECIFICATION

(45) Date of publication and mention of the grant of the patent:
02.11.2016 Bulletin 2016/44

(51) Int Cl.:
A43B 13/18 (2006.01) A43B 17/06 (2006.01)

(21) Application number: **11764249.6**

(86) International application number:
PCT/GB2011/051690

(22) Date of filing: **09.09.2011**

(87) International publication number:
WO 2012/032357 (15.03.2012 Gazette 2012/11)

(54) RESILIENT PAD FOR FOOTWEAR

NACHGIEBIGE UNTERLAGE FÜR SCHUHE
SEMELLE ÉLASTIQUE POUR CHAUSSURE

(84) Designated Contracting States:
AL AT BE BG CH CY CZ DE DK EE ES FI FR GB GR HR HU IE IS IT LI LT LU LV MC MK MT NL NO PL PT RO RS SE SI SK SM TR

(74) Representative: **Mohun, Stephen John**
Dehns Mohun LLP
13/14 Park Place
Leeds LS1 2SJ (GB)

(30) Priority: **10.09.2010 GB 201015073**

(56) References cited:
WO-A1-2007/031774 WO-A2-02/41720
CN-A- 101 884 452 DE-A1- 19 621 705

(43) Date of publication of application:
17.07.2013 Bulletin 2013/29

(73) Proprietor: **Harrison Spinks Components Limited**
Leeds
West Yorkshire LS11 5SN (GB)

• **DATABASE WPI Week 201108 Thomson Scientific, London, GB; AN 2010-Q31555 XP002667011, & CN 101 884 452 A (WUJIANG DONGTA SHOES CO LTD) 17 November 2010 (2010-11-17)**

(72) Inventor: **SPINKS, Simon Paul**
Cawood Yorkshire YO8 3SN (GB)

EP 2 613 656 B1

Note: Within nine months of the publication of the mention of the grant of the European patent in the European Patent Bulletin, any person may give notice to the European Patent Office of opposition to that patent, in accordance with the Implementing Regulations. Notice of opposition shall not be deemed to have been filed until the opposition fee has been paid. (Art. 99(1) European Patent Convention).

Description

[0001] The present invention relates to a resilient pad or panel for footwear, and is concerned in particular with a resilient pad or panel for footwear in which the resilience is provided at least in part by a plurality of coil springs.

[0002] There are many examples of footwear using springs of one kind or another in the prior art. Some are specialist boots and shoes used either for sport or other specific purposes where an extra degree of resilience is required in the heel or sole of the footwear. Other examples of footwear incorporating a spring include orthopaedic shoes or boots that are designed to provide some medical benefit to the wearer.

[0003] One such previously considered sole for a shoe is disclosed in US patent number 4,910,884 which describes the use of two helical plastic springs in a shoe, with one spring being positioned in the heel and the other at the toe.

[0004] However, coil springs have never found widespread application in mainstream footwear, and examples of soles comprising more than one spring are rare. This is assumed partly to be due to technical difficulties in reliably manufacturing shoes and boots with coil springs, and partly due to the associated cost. In a shoe-making method the handling of an individual spring, and its insertion into a composite sole, presents challenges that have limited the appeal of coil spring technology in mass-market footwear. DE19621705 describes a sole insert consisting of two layers of a soft wear resistant material, such as leather, which are sown together with crossing rows of stitches. A third layer is placed between the two layers. This layer has a large number of cells with square bases. Pre-loaded springs are mounted inside the pads. The springs are wound into a conically shaped spiral. The cells with springs protrude through holes in the top layer of the insert. Embodiments of the present invention aim to provide a pad or panel for a shoe, boot or other article of footwear which provides improved support or comfort to the wearer by employing a plurality of coil springs.

[0005] The present invention is defined in the attached independent claims to which reference should now be made. Further, preferred features may be found in the sub-claims appended thereto.

[0006] According to one aspect of the present invention there is provided a resilient pad or panel for an article of footwear, the pad or panel comprising a plurality of pocketed springs.

[0007] The pad or panel preferably comprises a plurality of springs, each of which is located in a discrete pocket formed between two layers of material. The two layers of material are preferably bonded or otherwise attached together at least at locations between the springs.

[0008] The springs are preferably coil springs which may be of wire and are preferably of stainless steel or titanium. The springs are preferably wider than they are tall, i.e. they have a diameter which is greater than the

height of the spring when the spring is in the pocket.

[0009] The pad or panel may be substantially co-extensive in plan with a heel of a wearer of the article of footwear.

5 **[0010]** The pad or panel may be substantially co-extensive in plan with a ball of a foot of a wearer of the article of footwear.

[0011] In a preferred arrangement the pad or panel is substantially co-extensive in plan with a foot of the wearer of the article of footwear.

10 **[0012]** Preferably the pad or panel is flexible in a lateral direction, generally perpendicular to the axis of the springs.

[0013] The pad or panel may include a plurality of zones in which springs from different zones have at least one different characteristic. The characteristic may be the height of the spring. Alternatively or in addition the characteristic may be the stiffness of the spring.

15 **[0014]** In a preferred arrangement the zones are arranged to accommodate the profile of a foot of the wearer of the article of footwear.

20 **[0015]** The pad or panel may comprise more than one layer of pocketed springs.

[0016] In a preferred arrangement the pad or panel includes at least one additional substrate layer above or below a layer of springs and/or between layers of springs. The additional substrate layer may comprise natural material and preferably comprises one or more of: hemp, wool, silk, cotton, mohair, cashmere, feather, down, and alpaca.

25 **[0017]** The invention also includes an article of footwear having at least one resilient pad or panel according to any statement herein.

30 **[0018]** The invention also provides an insert for an article of footwear, the insert comprising a resilient pad or panel according to any statement herein.

35 **[0019]** In accordance with another aspect of the invention there is provided a method of manufacturing an article of footwear, the method comprising inserting into a cavity in the sole and/or heel of the article of footwear a resilient pad or panel according to any statement herein.

40 **[0020]** The invention also provides a method of manufacturing an article of footwear, the method comprising moulding a sole and/or upper portion of the article of footwear around a resilient pad or panel according to any statement herein.

45 **[0021]** The present invention may comprise any combination of the features or limitations referred to herein, except such a combination of features as are mutually exclusive.

50 **[0022]** Preferred embodiments of the present invention will now be described by way of example only with reference to the accompanying diagrammatic drawings in which:

55

Figure 1 shows schematically, in plan view, a resilient pad for an article of footwear, in accordance with an embodiment of the present invention;

Figure 2 shows a schematic cross-section taken along line A-A' of Figure 1;

Figure 3 is a more detailed view of part of the section of Figure 2;

Figure 4 is a schematic plan view of an alternative embodiment of resilient pad;

Figure 5 is a schematic plan view of a further alternative embodiment of resilient pad;

Figure 6 is a longitudinal schematic section of part of an article of footwear, showing a still further alternative embodiment of resilient pad;

Figure 7 is an exploded view depicting a method of manufacturing an article of footwear in accordance with an embodiment of the present invention;

Figure 8 illustrates another method of manufacturing an article of footwear according to another embodiment of the present invention; and

Figure 9 is a detailed view of part of Figure 8.

[0023] Resilient pads for articles of footwear, in accordance with embodiments of the present invention, comprise panels of pocketed coil springs, which are sometimes referred to as encased springs. The panels typically comprise an array of metallic coil springs individually encased in pockets formed by bonding or otherwise joining together layers of material. A convenient process for manufacturing such a panel is described in our own co-pending European patent application published as EP 1 993 947.

[0024] The springs are typically wider than they are tall, i.e. their diameter is greater than the height of the spring when in the pocket. The panel is stable, resilient and workable. Its plan shape can be cut to suit the desired shape of the article of footwear, and it is generally flexible both in-plane, and transversely to this, i.e. laterally, which allows for it to be easily accommodated in a cavity or sleeve in the article of footwear.

[0025] Figure 1 shows generally at 10 a resilient panel according to a first embodiment of the invention. The panel is generally foot-shaped and comprises an array of discrete pocketed springs 12 of stainless steel, each housed in its own pocket of spun-bond polyester material.

[0026] Figure 2 is a sectional view taken along line A-A' of Figure 1. Upper and lower sheets 14a and 14b of spun-bond polyester are bonded together between springs 12 to form the pockets.

[0027] Figure 3 is an enlarged schematic view of part of the section of Figure 2 in which the coil springs 12 can be seen in the pockets between the layers 14a and 14b.

[0028] The incorporation of such a panel 10 into the sole or heel or both of an article of footwear may provide

enhanced comfort for the wearer. Because of the high number of yielding yet resilient springs the panel can readily conform to the profile of the wearer's foot.

[0029] In the example of Figure 1 the springs 12 are all of substantially identical stiffness, which may be selected by appropriate choice of gauge for the metal wire forming the springs. However the springs need not all be of the same stiffness.

[0030] Figure 4 shows an alternative embodiment in which the resilient panel has three distinct zones 16, 18 and 20. The first and third zones 16 and 20 comprise springs of greater stiffness than those in zone 18, where less pressure would normally be applied by a wearer's foot, when the panel is incorporated into an article of footwear.

[0031] Figure 5 shows a further variant in which the entire panel has springs of the same stiffness except for two zones 22 and 24 respectively in the areas of the heel and ball of the foot where the greatest pressure is normally applied. In zones 22 and 24 springs having greater stiffness, due to a thicker gauge of wire, have been utilised.

[0032] Figure 6 shows schematically a longitudinal section through a shoe 26 having a sole 28 that includes a resilient panel 30 of the kind described above. A toe portion 32, which will be located beneath the ball of a wearer's foot, and a heel portion 34, which will be located beneath a wearer's heel in use, comprise pocketed springs of a first size. A portion 36 of the panel 30 that lies beneath the arch of a wearer's foot comprises bigger springs that are designed to be stiffer and that will therefore deflect less, allowing the contour of the wearer's foot to be fully supported.

[0033] Of course the springs can be chosen for their stiffness and size, and can be grouped into zones and combined in such a way as to provide specifically desired performance characteristics. These characteristics can be determined by the type of footwear and/or the wearer. For example sports shoes can be designed with resilience characteristics to match the conditions of a particular sport, whilst leisure shoes can be tailored for comfort and orthopaedic shoes can be constructed for maximum medical benefit.

[0034] The panel can either be inserted into a cavity or pouch preformed in the article of footwear, in the form of a cassette, or else the panel can be placed in a mould and the sole - or another part, or the entire article of footwear - can be moulded around it. Alternatively the panel can form part of an insole that can simply be placed inside the shoe for some applications.

[0035] Figure 7 is a schematic exploded view depicting one method of manufacture of a shoe according to an embodiment of the invention. A one-piece base portion 40, comprising an integral sole and heel of a shoe, has a cavity 42 into which is placed a resilient panel 44 comprising an array of pocketed springs as described above. Adhesive (not shown) may be utilised to attach the panel 44 firmly to the base portion 40. Then a top layer 46,

which may comprise natural or man-made material and may be woven or non-woven, is placed above the panel 44 as a "lid" and is fixed thereto by adhesive (not shown). The remainder of the shoe, i.e. the upper part (not shown), is then attached to the base portion 40 by a known method, such as stitching, welding or the application of adhesive.

[0036] Figure 8 shows an alternative method of manufacturing a shoe, in accordance with the present invention. In the Figure 8 embodiment the panel 44 is inserted into the cavity as with the previous embodiment. But instead of attaching the panel 44 to the base 40 with adhesive and then placing the top layer over the panel, in this embodiment a foam rubber 48 or similar material is injected, poured or otherwise caused to flow over and/or around the panel 44, substantially filling the cavity 42, before adding an inner sole 50 and attaching the upper (not shown).

[0037] Figure 9 is a detailed view of the part circled at B in Figure 8.

[0038] Whereas the examples shown in the drawings are substantially full foot panels, some benefit may be derived merely from a heel panel or a panel for the ball of the foot, or two or more separate panels for different regions of the foot. Two or more panels may be placed on top of one another to provide additional comfort.

[0039] An additional substrate layer may be placed on top of the pocketed springs, or below them, or in between adjacent layers of springs to improve comfort and/or performance of the panel. The additional layer, which is not shown in the drawings, may comprise natural materials such as hemp, to assist in the recyclability of the footwear.

[0040] The term "article of footwear" used above should be taken to mean anything that can be worn on the foot, such as but not limited to a shoe, boot, slipper, sandal or sock.

[0041] Whilst endeavouring in the foregoing specification to draw attention to those features of the invention believed to be of particular importance, it should be understood that the applicant claims protection in respect of any patentable feature or combination of features referred to herein, and/or shown in the drawings, whether or not particular emphasis has been placed thereon.

Claims

1. A method of manufacturing an article of footwear, the method comprising inserting into a cavity in the sole and/or heel of the article of footwear a resilient pad or panel, the pad or panel comprising a plurality of pocketed springs, each of which is located in a discrete pocket formed between two layers of material, the two layers of material being bonded or otherwise attached together at least at locations between the springs, wherein the pad or panel is flexible in a lateral direction, generally perpendicular to the axis of the springs.

2. A method of manufacturing an article of footwear, the method comprising moulding a sole and/or upper portion of the article of footwear around a resilient pad or panel, the pad or panel comprising a plurality of pocketed springs, each of which is located in a discrete pocket formed between two layers of material, the two layers of material being bonded or otherwise attached together at least at locations between the springs, and wherein the pad or panel is flexible in a lateral direction, generally perpendicular to the axis of the springs.

3. A method according to Claim 1 or 2, wherein the springs are wider than they are tall, i.e. they have a diameter which is greater than the height of the spring when in the pocket.

4. A method according to Claim 1 or 2, wherein the pad or panel is substantially co-extensive in plan with a heel of a wearer of the article of footwear.

5. A method according to any of the preceding claims, wherein the pad or panel is substantially co-extensive in plan with a ball of a foot of a wearer of the article of footwear.

6. A method according to any of the preceding claims wherein the pad or panel is substantially co-extensive in plan with a foot of the wearer of the article of footwear.

7. A method according to any of the preceding claims, wherein the pad or panel includes a plurality of zones in which springs from different zones have at least one different characteristic.

8. A method according to Claim 7, wherein the characteristic is the height of the spring.

9. A method according to Claim 7 or 8, wherein the characteristic is the stiffness of the spring.

10. A method according to any of the Claims 7 to 9, wherein the zones are arranged to accommodate the profile of a foot of the wearer of the article of footwear.

11. A method according to any of the preceding claims comprising at least one additional substrate layer above or below a layer of springs and comprising natural material.

Patentansprüche

1. Verfahren zum Herstellen eines Fußbekleidungsgegenstands, wobei das Verfahren umfasst, dass in einen Hohlraum in der Sohle und/oder in dem Absatz

- des Fußbekleidungsgegenstands ein elastisches Kissen oder eine elastische Platte eingesetzt wird, wobei das Kissen oder die Platte eine Anzahl von eingetaschten Federn umfasst, von denen jede in einer einzelnen Tasche angeordnet ist, die zwischen zwei Materialschichten gebildet ist, wobei die beiden Materialschichten zumindest an Stellen zwischen den Federn verbunden oder in sonstiger Weise aneinander befestigt sind, wobei das Kissen oder die Platte in einer seitlichen Richtung flexibel ist, im Wesentlichen senkrecht zu der Achse der Federn.
2. Verfahren zum Herstellen eines Fußbekleidungsgegenstands, wobei das Verfahren umfasst, dass eine Sohle und/oder ein oberer Bereich des Fußbekleidungsgegenstands um ein elastisches Kissen oder eine elastische Platte herum geformt wird, wobei das Kissen oder die Platte eine Anzahl von eingetaschten Federn umfasst, von denen jede in einer einzelnen Tasche angeordnet ist, die zwischen zwei Materialschichten gebildet ist, wobei die beiden Materialschichten zumindest an Stellen zwischen den Federn verbunden oder in sonstiger Weise aneinander befestigt sind, wobei das Kissen oder die Platte in einer seitlichen Richtung flexibel ist, im Wesentlichen senkrecht zu der Achse der Federn.
3. Verfahren nach Anspruch 1 oder 2, **dadurch gekennzeichnet, dass** die Federn breiter sind als sie hoch sind, d.h. sie haben einen Durchmesser, der größer als die Höhe der Federn ist, wenn sie sich in der Tasche befinden.
4. Verfahren nach Anspruch 1 oder 2, **dadurch gekennzeichnet, dass** das Kissen oder die Platte sich im Wesentlichen in einer gemeinsamen Ebene mit einer Ferse eines Trägers des Fußbekleidungsgegenstands erstreckt.
5. Verfahren nach einem der vorangehenden Ansprüche, **dadurch gekennzeichnet, dass** das Kissen oder die Platte sich im Wesentlichen in einer Ebene mit einem Fußballen eines Trägers des Fußbekleidungsgegenstands erstreckt.
6. Verfahren nach einem der vorangehenden Ansprüche, **dadurch gekennzeichnet, dass** sich das Kissen oder die Platte im Wesentlichen in einer Ebene mit einem Fuß des Trägers des Fußbekleidungsgegenstands erstreckt.
7. Verfahren nach einem der vorangehenden Ansprüche, **dadurch gekennzeichnet, dass** das Kissen oder die Platte eine Anzahl von Zonen enthält, in denen Federn von unterschiedlichen Zonen zumindest eine unterschiedliche Charakteristik aufweisen.
8. Verfahren nach Anspruch 7, **dadurch gekennzeichnet, dass** die Charakteristik die Höhe der Feder ist.
9. Verfahren nach Anspruch 7 oder 8, **dadurch gekennzeichnet, dass** die Charakteristik die Härte der Feder ist.
10. Verfahren nach einem der Ansprüche 7 bis 9, **dadurch gekennzeichnet, dass** die Zonen so angeordnet sind, dass sie das Profil eines Fußes des Trägers des Fußbekleidungsgegenstands abdecken.
11. Verfahren nach einem der vorangehenden Ansprüche, umfassend zumindest eine zusätzliche Substratschicht oberhalb oder unterhalb einer Schicht von Federn, und bestehend aus natürlichem Material.

Revendications

1. Procédé de fabrication d'un article de chaussure, le procédé comprenant l'insertion dans une cavité sur la plante et/ou le talon du pied de l'article de chaussure d'un rembourrage ou panneau élastique, le rembourrage ou panneau comprenant une pluralité des ressorts agencés dans des poches, chacun d'eux étant situé dans une poche discrète formée entre deux couches de matériau, les deux couches de matériau étant collées ou fixées ensemble d'une autre manière au moins à des emplacements entre les ressorts, dans lequel le rembourrage ou panneau est flexible dans une direction latérale, sensiblement perpendiculaire à l'axe des ressorts.
2. Procédé de fabrication d'un article de chaussure, le procédé comprenant le moulage d'une plante et/ou partie supérieure de l'article de chaussure autour d'un rembourrage ou panneau élastique, le rembourrage ou panneau comprenant une pluralité de ressorts agencés dans des poches, chacun d'eux étant situé dans une poche discrète formée entre deux couches de matériau, les deux couches de matériau étant collées ou fixées ensemble d'une autre manière au moins à des emplacements entre les ressorts, et dans lequel le rembourrage ou panneau est flexible dans une direction latérale, sensiblement perpendiculaire à l'axe des ressorts.
3. Procédé selon la revendication 1 ou 2, dans lequel les ressorts sont plus larges que hauts, c'est-à-dire qu'ils présentent un diamètre qui est supérieur à la hauteur du ressort lorsqu'il est dans la poche.
4. Procédé selon la revendication 1 ou 2, dans lequel le rembourrage ou panneau s'étend sensiblement dans le plan d'un talon d'un porteur de l'article de chaussure.

5. Procédé selon l'une quelconque des revendications précédentes, dans lequel le rembourrage ou panneau s'étend sensiblement dans le plan d'une cheville d'un pied d'un porteur de l'article de chaussure. 5
6. Procédé selon l'une quelconque des revendications précédentes dans lequel le rembourrage ou panneau s'étend sensiblement dans le plan d'un pied du porteur de l'article de chaussure. 10
7. Procédé selon l'une quelconque des revendications précédentes, dans lequel le rembourrage ou panneau comporte une pluralité de zones dans lesquelles des ressorts de différentes zones présentent au moins une caractéristique différente. 15
8. Procédé selon la revendication 7, dans lequel la caractéristique est la hauteur du ressort.
9. Procédé selon la revendication 7 ou 8, dans lequel la caractéristique est la rigidité du ressort. 20
10. Procédé selon l'une quelconque des revendications 7 à 9, dans lequel les zones sont agencées de manière à s'adapter au profil d'un pied du porteur de l'article de chaussure. 25
11. Procédé selon l'une quelconque des revendications précédentes, comprenant au moins une couche de substrat additionnelle au-dessus ou au-dessous d'une couche de ressorts et comprenant un matériau naturel. 30

35

40

45

50

55

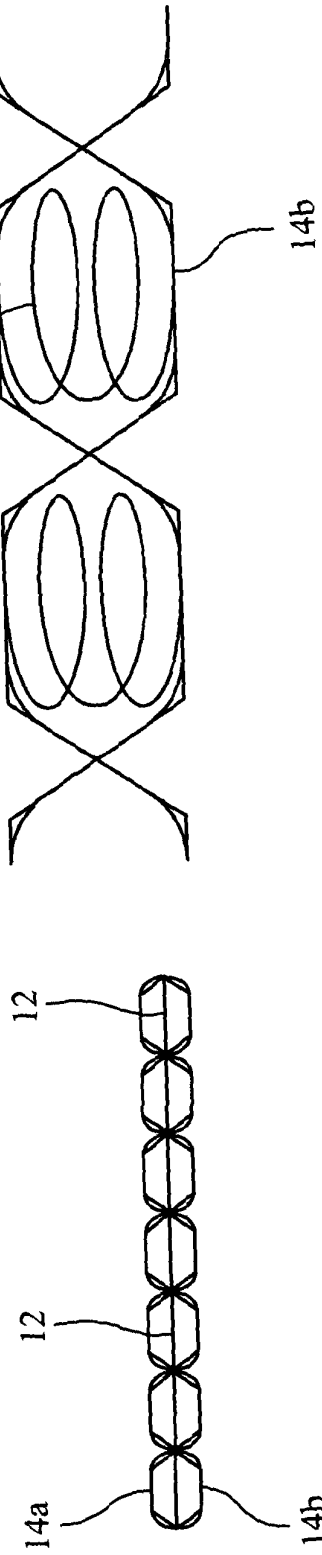
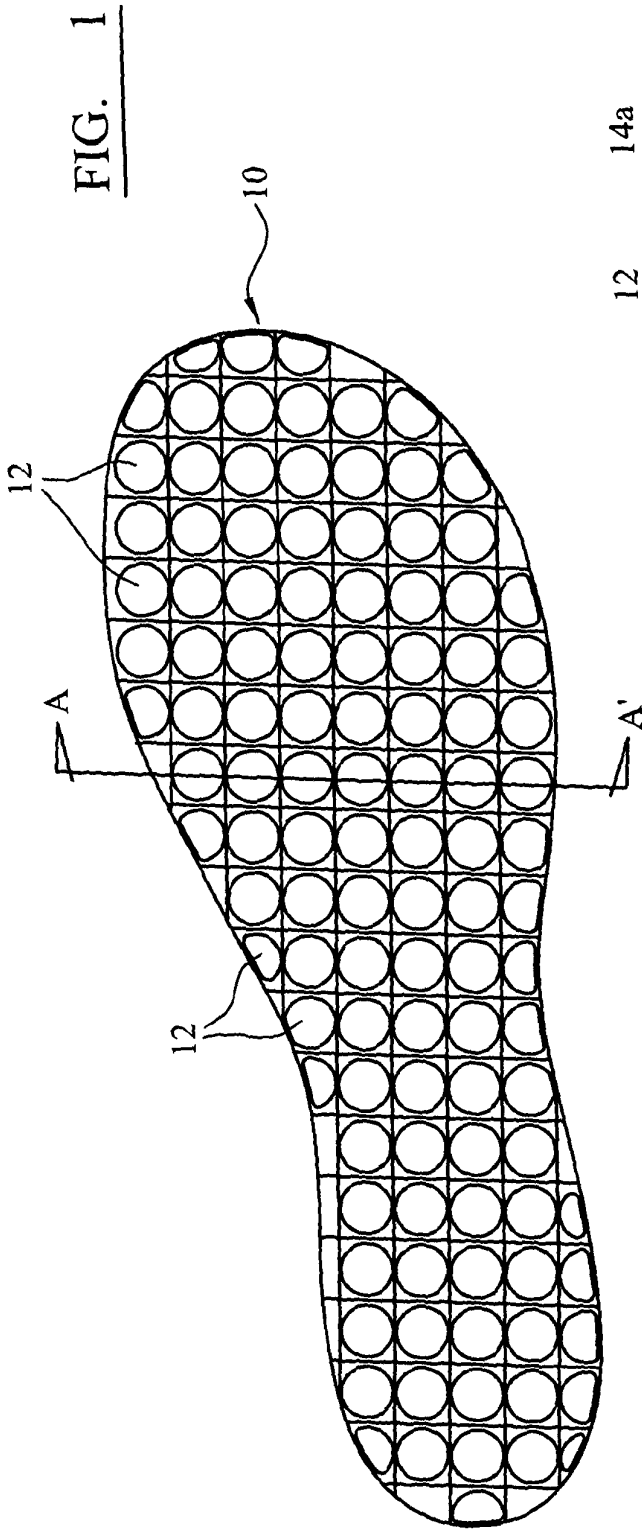

FIG. 3

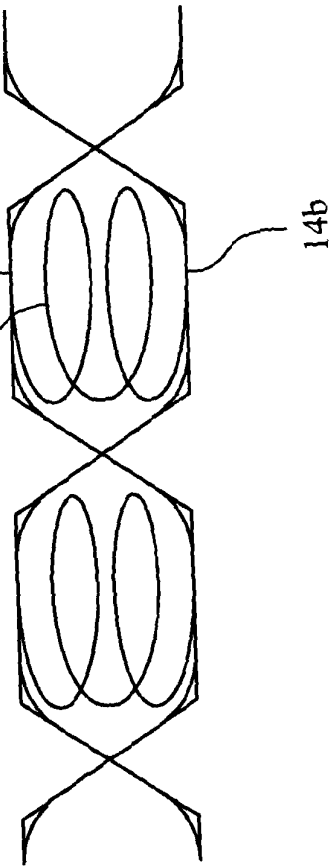

FIG. 2

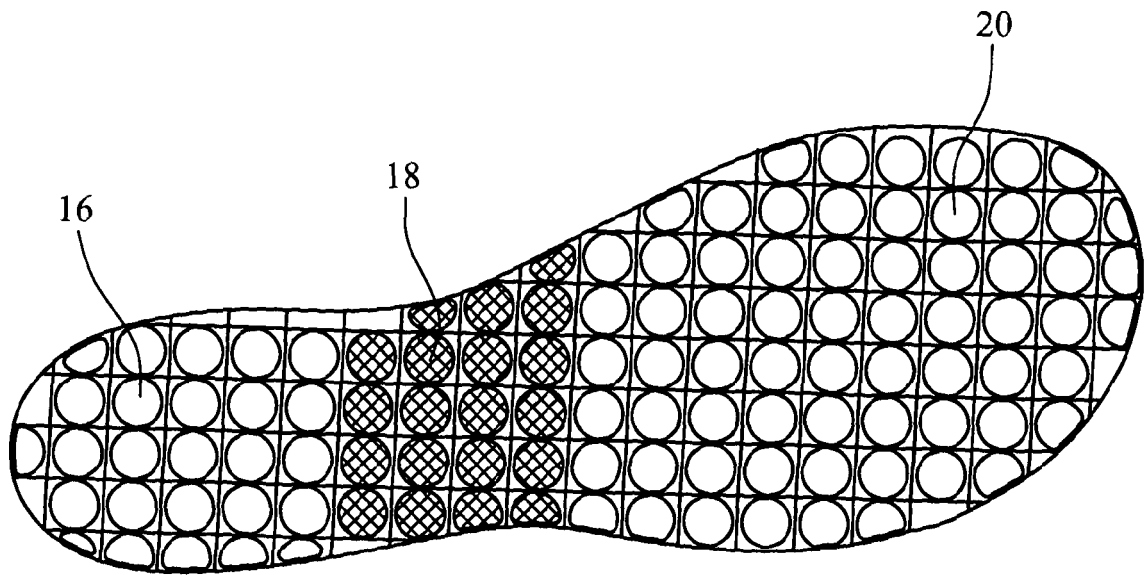

FIG. 4

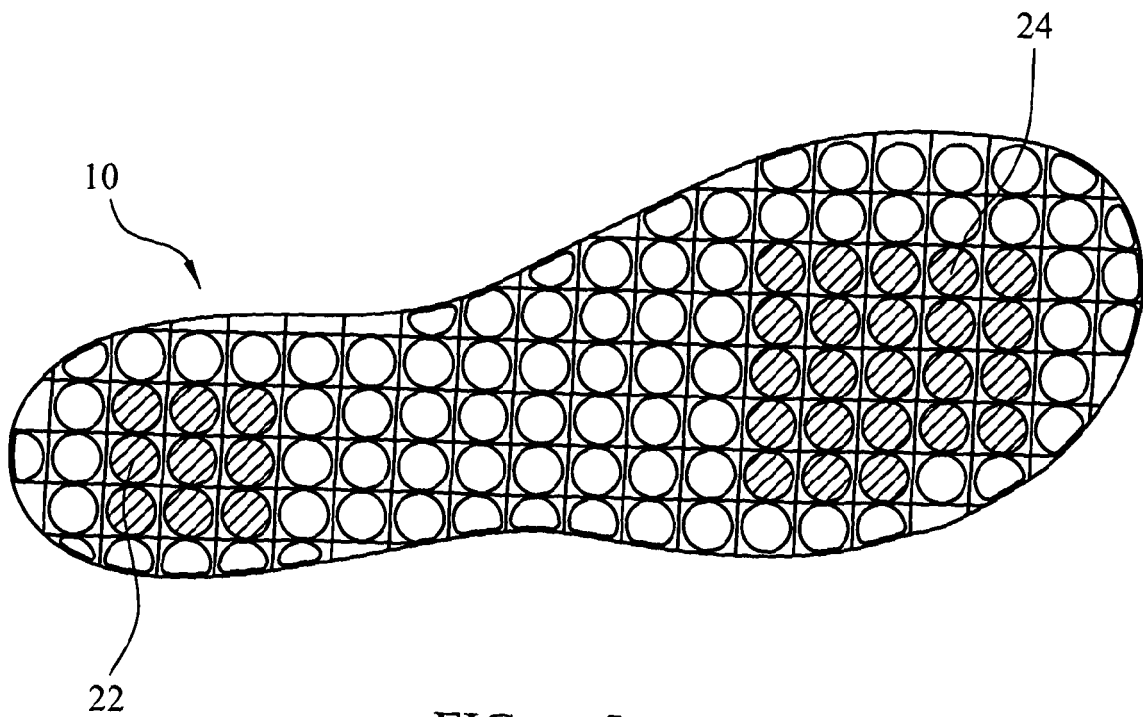

FIG. 5

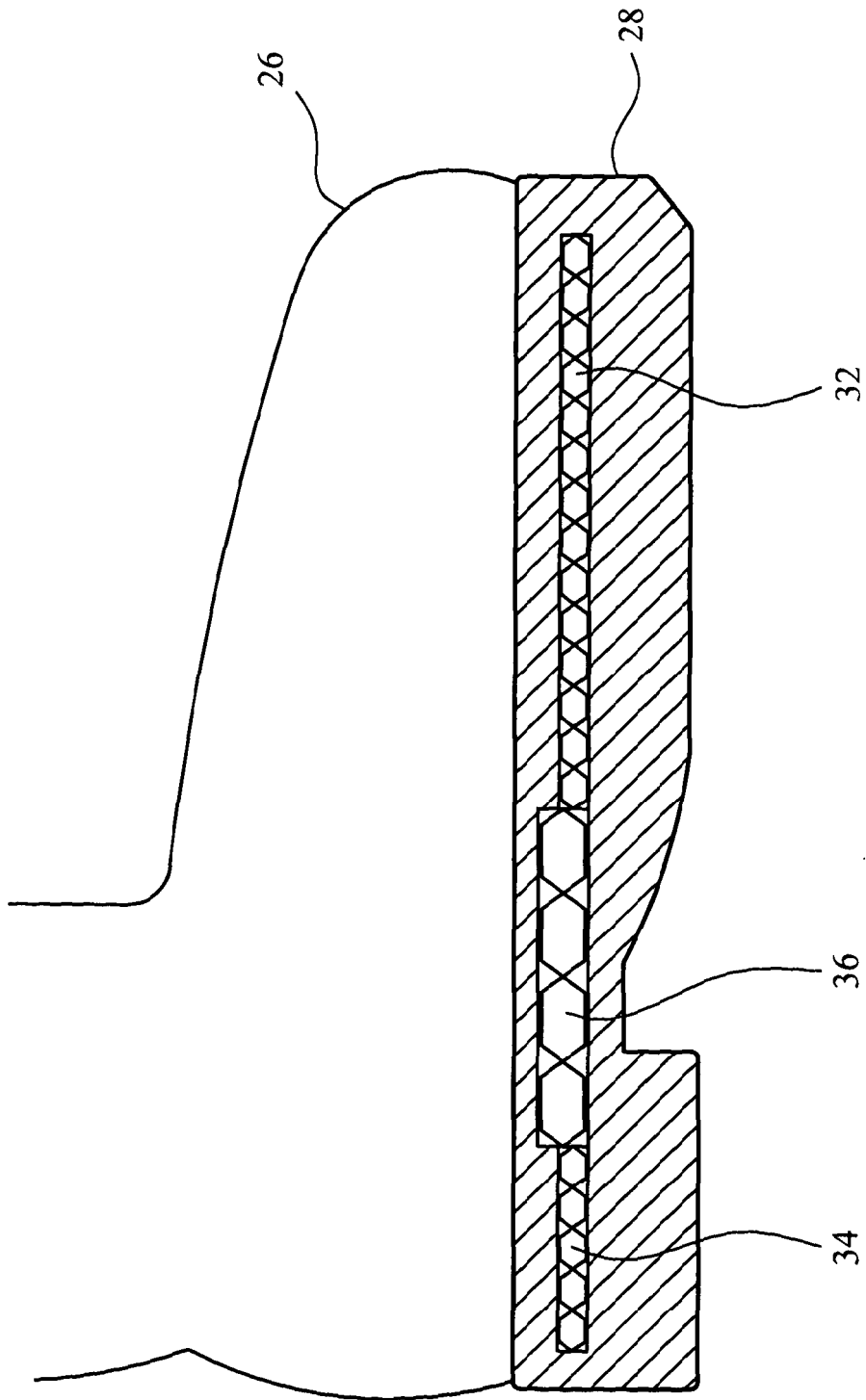

FIG. 6

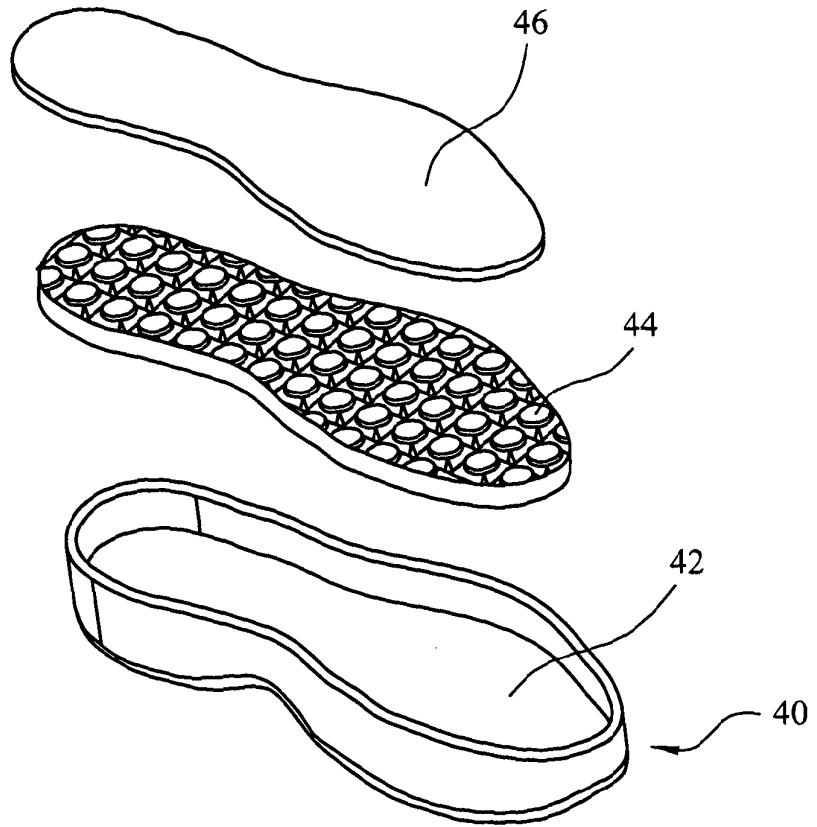

FIG. 7

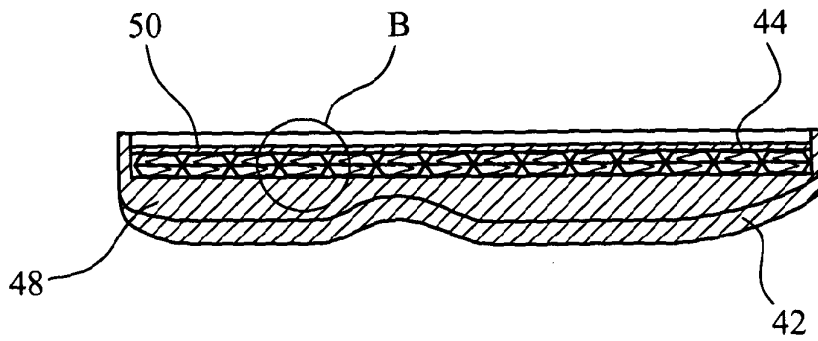

FIG. 8

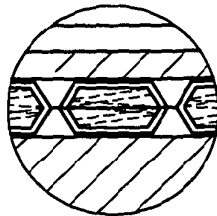

FIG. 9

REFERENCES CITED IN THE DESCRIPTION

This list of references cited by the applicant is for the reader's convenience only. It does not form part of the European patent document. Even though great care has been taken in compiling the references, errors or omissions cannot be excluded and the EPO disclaims all liability in this regard.

Patent documents cited in the description

- US 4910884 A [0003]
- DE 19621705 [0004]
- EP 1993947 A [0023]