

(19)



(11)

EP 2 617 659 B1

(12)

EUROPEAN PATENT SPECIFICATION

(45) Date of publication and mention of the grant of the patent:
30.04.2014 Bulletin 2014/18

(51) Int Cl.:
B65D 65/46 (2006.01) **B65D 81/32 (2006.01)**
B65D 75/32 (2006.01) **C11D 17/04 (2006.01)**

(21) Application number: **12000317.3**

(22) Date of filing: **19.01.2012**

(54) **Cleaning agent product**

Reinigungsmittelprodukt

Produit d'agent de nettoyage

(84) Designated Contracting States:
AL AT BE BG CH CY CZ DE DK EE ES FI FR GB GR HR HU IE IS IT LI LT LU LV MC MK MT NL NO PL PT RO RS SE SI SK SM TR

(43) Date of publication of application:
24.07.2013 Bulletin 2013/30

(73) Proprietor: **Lakma Strefa Sp.z o.o.**
43-254 Warszowice k/Zor (PL)

(72) Inventor: **Zietek, Józef**
43-385 Jasienica (PL)

(74) Representative: **Zurhorst, Stefan et al**
Menzelstraße 40
70192 Stuttgart (DE)

(56) References cited:
EP-A1- 1 375 637 **EP-A2- 1 647 494**
WO-A1-03/029102 **WO-A1-2008/087414**
US-A1- 2007 157 572

EP 2 617 659 B1

Note: Within nine months of the publication of the mention of the grant of the European patent in the European Patent Bulletin, any person may give notice to the European Patent Office of opposition to that patent, in accordance with the Implementing Regulations. Notice of opposition shall not be deemed to have been filed until the opposition fee has been paid. (Art. 99(1) European Patent Convention).

Description

[0001] The invention relates to a cleaning agent product comprising a water soluble pouch according to the preamble of claim 1.

[0002] Cleaning agents for laundry, dish washing, floor cleaning and the like are used in private households in a liquid or solid state form. Such agents are provided in bottles for liquids or in boxes for powders, which allows a free and unrestricted dosing by the user. Besides this, that packaging cost is low. However, many consumers feel uncomfortable when having to find themselves the right dosing, and there is some risk of a wrong dosing applied. In addition, the liquid or powder tends to spill during handling, which requires additional cleaning work.

[0003] In order to overcome said drawbacks, packaged dosing units were developed and found a good acceptance by the users, wherein pressed powder tablets are individually packaged in small single plastic foil sachets or pouches. Upon tearing up the plastic foil, the pressed powder tablet could be taken out by the user and inserted into the clothes washer or dish washing machine without caring about the required dose. However, tearing up the foil sachet is quite often not easy, especially when having wet hands. In addition, the plastic sachets require a solid state filling and are not practical for liquid cleaning agents in single unit doses. The opened sachets need to be disposed of, which is regarded as uncomfortable, and which adds to environmental burden.

[0004] As a further development, cleaning agent products comprising a water soluble pouch became more and more popular. The water soluble pouch is filled with single unit doses of the required cleaning agents and can be inserted into the machine without opening the pouch. During the washing process and upon contact with water, the pouch dissolves and sets the cleaning agents free. The handling of such pouches is very comfortable. Without the need of opening the pouch, the manufacturer is not limited to solid state tablet fillings, but is free to provide a powder or even a liquid filling. Pouches each having two or more separate chambers can be produced in order to separate different agents until they are released into the washing water. In specific, multi chamber pouches allow the use of both a powder and a liquid filling within a single unit.

[0005] However, a powder or liquid filling does not have any own form stability. In order to obtain a more or less rigid product for easy handling, the form stability has to be created by the pouch itself. The problem of form stability is even worse with multi chamber pouches, since the elastic divisional sealing strip between two adjacent chambers acts as a hinge, which tends to make the product flexible to an undesired extent.

[0006] A multi chamber pouch made of injection moulded water soluble material has been proposed in the past, wherein the injection moulding process leads to quite high wall thicknesses. These wall thicknesses add to form stability even in the area of the divisional sealing

strip. However, the injection moulding process is cost intensive and requires a costly amount of water soluble material to produce the pouch.

[0007] As an alternative, multi chamber pouches are known made of water soluble, deep drawn foil. Due to the low foil thickness and the easy deep drawing process, the cost contribution of the pouch to the entire product is quite low. However, the comparable thin foil is flexible especially with respect to bending. This holds true in particular for a side by side arrangement of two or more pouch chambers being formed in a thermoformed water soluble foil arranged in two stacked foil layers. Such pouches in different embodiments are known for example from EP 1 375 637 A1, wherein multiple side by side arranged chambers are separated by divisional sealing strips of two stacked and sealed foil layers. Due to their low total thickness and the resulting bending flexibility such divisional sealing strips may act as undesired hinge lines. Therefore, a multi chamber pouch in a double layer configuration has been proposed. One chamber is stacked over one or two other chambers, which leads to a mechanically robust and nearly non bending flexible product. The stacked configuration requires three layers of foil, at least two of them being deep drawn in a plastically deforming manner to form the different chambers, while the third foil as an intermediate foil separates them. The deep drawing process of at least two foils is cost intensive, while the need for three foil layers in terms of required material adds to the total product costs significantly as well.

[0008] The object of the present invention is to provide a multi chamber cleaning agent product comprising a water soluble pouch with improved structural form stability and reduced material and production effort.

[0009] This object is solved by the cleaning agent product according to claim 1.

[0010] According to the invention a cleaning agent product is proposed, comprising a water soluble pouch having a first chamber and a second chamber being separated from the first chamber, wherein the first chamber and the second chamber are each filled with a cleaning agent, wherein the pouch is made of a water soluble base foil and of a water soluble lid foil being tightly connected to each other, wherein the base foil is deep drawn in a plastically deforming manner to form the first chamber and the second chamber, wherein the first chamber comprises a first base area, the second chamber a second base area and the entire cleaning agent product a third base area, wherein the first base area of the first chamber comprises a concave section on its side facing the second chamber, wherein the second base area of the second chamber comprises a convex section on its side facing the first chamber, wherein the convex section of the second chamber extends into the concave section of the first chamber. The second base area of the second chamber has aside to its convex section at least one concave section adjacent to at least one convex section of the first base area. The third base area of the cleaning agent

product is at least approximately circular shaped.

[0011] The pouch is made of two layers of foil only, which reduces manufacturing cost and effort. The thin foil is flexible especially with respect to bending. However, the convex base area section extending into the concave base area section, and the second base area of the second chamber having aside to its convex section at least one concave section adjacent to at least one convex section of the first base area, lead to a separating strip between both chamber base areas without a straight line. The missing straight line form of the separating strip produces a bending stiffness of the whole product, although the separating strip taken alone does not have any technically relevant bending stiffness by itself. The circular base area of the whole product maximizes the mass concentration of the filling with minimum required foil material. The mass concentration in conjunction with the increased bending stiffness leads to a product with high structural form stability, which therefore can easily be handled by the user.

[0012] In a preferred embodiment, between the first chamber and the second chamber a separating strip is present having a mean strip width. The convex section of the second chamber extends into the concave section of the first chamber by a first extension width related to the mean strip width. The first extension width is at least approximately equal to or greater than the mean strip width. In a further preferred embodiment, between the first chamber and the second chamber a separating strip is present providing along the separating strip a sealed joint with a mean seal width to tightly connect the lid foil to the base foil. The convex section of the second chamber extends into the concave section of the first chamber by a second extension width related to the mean seal width. The second extension width has at least the double value, in particular at least the triple value of the mean seal width.

[0013] Both definitions of the minimum required extension width of the convex section into the concave section are based on different points of view: For manufacturing reasons, the separating strip width must be greater than the seal width. During manufacturing, the separating strip width is relevant for the geometric determination of the chambers base areas. Based on this point of view, the first of the above mentioned definitions relates the minimum required extension to the separating strip width. After manufacturing, the internal pressure of the filled cleaning agents inflates the chambers to an extent, that both chambers are separated from each other by the width of the sealed joint. Based on this point of view, the second of the above mentioned definitions relates the minimum required extension to the seal width. Both definitions, in sum or as an alternative, provide a minimum required extension width of the convex section into the concave section, which leads to the desired form stability.

[0014] In a preferred embodiment, the separating strip and/or the sealed joint have at least along the major part of their length a constant strip width and/or a constant

seal width respectively. Said constant width leads to a constant width between adjacent chamber walls. Upon an applied flexing load, adjacent chamber walls of both chambers will be pressed together across a great area, thereby significantly supporting each other against a resulting deflection, which adds to the desired form stability.

[0015] In a preferred embodiment, the first chamber has a first depth and the second chamber a second depth. The smaller one of the two depths is greater than the mean strip width at least by the factor of three, and in particular is at least approximately greater than the mean strip width by the factor of four. In a further preferred embodiment, the first chamber has a first depth and the second chamber has a second depth. The smaller one of the two depths is greater than the mean seal width at least by the factor of six, and in particular is at least approximately greater than the mean seal width by the factor of eight. Again, as above with the required extension width of the convex section into the concave section, two different definitions of the same requirement are provided, one of which based on the mean strip width, and the other based on the mean seal width. In both cases, the minimum required chamber depth, in conjunction with said width, leaves only a negligible flexion deformation, until adjacent chamber walls of both chambers are be pressed together in order to prevent any further deflection.

[0016] In a preferred embodiment, the first chamber and/or the second chamber have at least at their side facing the respective other chamber a wall section with a draft angle being $\leq 7^\circ$ and in particular being at least approximately 5° . Although for manufacturing reasons greater draft angles could be of interest, said preferred draft angles add to the effect, that only a minimum of product deflection leads to the sought pressing together of adjacent chamber walls in order to prevent or at least minimize bending deflection of the whole product.

[0017] In a preferred embodiment, the second base area of the second chamber has aside to its convex section two mirror symmetrically disposed concave sections adjacent to two mirror symmetrically disposed convex sections of the first base area. The convex and adjacent concave sections are wedged together, which adds to the sought structural form stability.

[0018] In a preferred embodiment, the quotient of the first base area and the second base area is in a range from 1,4, inclusive, to 2,4, inclusive, preferably in a range from 1,7, inclusive, to 2,1, inclusive, and is in particular at least approximately 1,9. In a further preferred embodiment, the first chamber has a first volume and the second chamber has a second volume. The quotient of the first volume and the second volume is in a range from 1,8, inclusive, to 2,8, inclusive, preferably in a range from 2,1, inclusive, to 2,5, inclusive, and is in particular at least approximately 2,3. Upon keeping said relations, the user may grab the product at any one of its filled chambers without the risk, that the remaining chamber is too big and heavy to cause a product deflection beyond a desired

limit.

[0019] In a preferred embodiment, the base foil only and not the lid foil is deep drawn to form the first chamber and the second chamber. Thereby, the major part of the chamber volume is provided by the base foil with a significant chamber depth to one side only. This adds to the effect that upon flexion load adjacent chamber walls are pressed together in order to prevent or at least minimize bending deflection of the whole product. In addition, arrangements for deep drawing one foil only have to be provided, which reduces machine and manufacturing costs. The unformed lid foil does not have to meet special forming requirements and can therefore be chosen by less restrictive requirements.

[0020] In a preferred embodiment, the base foil and/or the lid foil have a thickness being in a range from 50 μm , inclusive, to 100 μm , inclusive, preferably in a range from 60 μm , inclusive, to 90 μm , inclusive, and being in particular at least approximately 76 μm . Although the foil thickness in said ranges is quite small and does not provide technically relevant bending stiffness, the completed product itself has a sufficient form stability and fulfils all requirements with respect to tightness both for powder and liquid fillings.

[0021] A preferred embodiment is hereafter described as an example of the invention by reference to the drawing. It is shown in

- Fig. 1 a perspective top view of an inventive cleaning agent product having two separate chambers;
- Fig. 2 a perspective bottom view of the cleaning agent product according to Fig. 1 with further details of the two separate chambers;
- Fig. 3 a top view of the cleaning agent product according to Fig. 1, 2 with geometric details of the chamber base areas and the separating strip;
- Fig. 4 the top view of Fig. 3 with further geometric details of the chamber base areas and the separating strip;
- Fig. 5 a side view of the cleaning agent product according to Fig. 1 to 4 with details of the deep drawn base foil;
- Fig. 6 a cross sectional view of the cleaning agent product according to Fig. 5 with details of the chamber walls.

[0022] Fig. 1 shows a perspective top view of an example embodiment of an inventive cleaning agent product. The cleaning agent product comprises a water soluble pouch 10, which is made of a water soluble base foil 5 and a water soluble lid foil 6, the latter one being shown in Fig. 6. The cleaning agent product has a generally circular shape. Within its circular shape, the base

foil 5 is deep drawn under influence of increased temperature and vacuum to form a first chamber 1 and a second chamber 2. The first chamber 1 and the second chamber 2 are separated from each other by a curved separating strip 9. In addition, both the first chamber 1 and the second chamber 2 are surrounded by a flat circular arc shaped flange 14, to which the flat separating strip 9 is connected. The flange 14 comprises with distance to its edges a circular arc shaped sealed joint 15, while the separating strip 9 comprises with distance to its edges along its length a sealed joint 11. The sealed joint 11 and the sealed joint 15 are interconnected to each other. Along their course the base foil 5 and the lid foil 6 (Fig. 6) are sealed together in a liquid- and powder-tight manner. Thereby, two tightly closed and separated chambers 1, 2 are formed.

[0023] The first chamber 1 is filled with a first cleaning agent 3, while the second chamber 2 is filled with a second cleaning agent 4, wherein the separating strip 9 and the sealed joints 11, 14 prevent the two cleaning agents 3, 4 to prematurely get in contact to each other and to mix up. The cleaning agents 3, 4 can be identical or different. In particular, they can be in a powder or liquid form. In the shown preferred embodiment, the first cleaning agent 3 is powder, while the second cleaning agent 4 is liquid. However, any other suitable and desired combination of the cleaning agents 3, 4 may be chosen.

[0024] The volume of the chambers 1, 2 and formulation of the cleaning agents 3, 4 are chosen and adapted to each other, that the entire cleaning agent product provides an amount of cleaning agents 3, 4 for one single unit dose application. Dependent on the type of the cleaning agents 3, 4, the inventive cleaning agent product may be used for laundry washing or dish washing in particular in a respective machine, for floor cleaning or any other cleaning application, where cleaning water comes into effect. Upon contact of the cleaning agent product with the cleaning water, the water soluble pouch 10 dissolves and sets the cleaning agents 3, 4 free in order to provide the correct, desired and readily usable mixture of water and cleaning agents 3, 4.

[0025] Fig. 2 shows a perspective bottom view of the cleaning agent product according to Fig. 1. From both Figs. 1 and 2 it can be seen, that the first chamber 1 is approximately kidney-shaped, while the second chamber 2 matches the convex side of the first chamber 1 kidney-shape, while leaving the separating strip 9 in between, and while maintaining the surrounding flange 14 with an approximately constant width.

[0026] Fig. 3 shows a top view of the cleaning agent product according to Figs. 1 and 2 in a production state, when the base foil 5 is already deep drawn to form the first chamber 1 and the second chamber 2, however without being filled. In this production state the separating strip 9 has a mean strip width b_s . The mean strip width b_s may vary along the course of the separating strip 9. In the preferred embodiment as shown in Fig. 3, the separating strip 9 has at least along the major part of its

length a constant strip width b_s .

[0027] The first chamber 1 has a first base area A_1 , while the second chamber 2 has a second base area A_2 . The entire cleaning agent product has a circular shaped third base area A_3 , which is delimited by the very outer, circular shaped edge of the flange 14. Besides said circular shaped third base area A_3 of the entire cleaning agent product, both the first base area A_1 of the first chamber 1 and the second base area A_2 of the second chamber 2 are mirror-symmetrically shaped and disposed with respect to a mirror axis, which is marked by a line V-V.

[0028] On said symmetry line the first base area A_1 of the first chamber 1 comprises a concave section 7 on its side facing the second base area A_2 of the second chamber 2, while the second base area A_2 of the second chamber 2 comprises on said symmetry line a convex section 8 on its side facing the first base area A_1 of the first chamber 1. The convex section 8 extends into the concave section in an overlapping manner by a first extension width b_{t1} related and measured to the separating strip 9 with its mean strip width b_s . In the opposite direction, the first base area A_1 of the first chamber 1 has at least one and in particular - as shown - two mirror-symmetrically disposed convex sections 12 aside to the concave section 7, a tangent on which serves as a base line to measure the first extension width b_{t1} . In addition, the second base area A_2 of the second chamber 2 has aside to its convex section 8 at least one and in particular - as shown - two mirror symmetrically disposed concave sections 13 adjacent to said convex sections 12 of the first base area A_1 .

[0029] The first extension width b_{t1} is at least approximately equal to and preferably greater than the mean strip width b_s . The quotient of the first base area A_1 and the second base area A_2 is in particular in a range from 1,4, inclusive, to 2,4, inclusive, and preferably in a range from 1,7, inclusive, to 2,1, inclusive. In the shown preferred embodiment, said quotient is at least approximately 1,9.

[0030] Fig. 4 shows a top view of the cleaning agent product according to Fig. 3, wherein the first chamber 1 is filled with the first cleaning agent 3, and the second chamber 2 is filled with the second cleaning agent 4. In addition, the base foil 5 is sealed by the lid foil 6 as shown in Fig. 6. This and the internal pressure of the cleaning agents 3, 4 leads to an elastic deformation of the base foil 5 to such an extent, that the two chambers 1, 2 are not anymore separated by the separating strip 9 with its strip width b_s as shown in Fig. 3. Due to the elastic deformation this separation is reduced to the sealed joint 11 of the separating strip 9, having a seal width b_u , which is more narrow than the strip width b_s of the non deformed separating strip 9 according to Fig. 3. In said filled state according to Fig. 4 the concave sections 7, 13 and the convex sections 8, 12 are identified in the same manner as along with Fig. 3. The sealed joint 11 may have a varying mean seal width b_u and has in the shown pre-

ferred embodiment at least along the major part of its length a constant seal width b_u . Related to said seal width b_u and to the convex sections 12, the convex section 8 of the second base area A_2 of the second chamber 2 extends in the concave section 7 of the first base area A_1 of the first chamber 1 by a second extension width b_{t2} . The second extension width b_{t2} has at least the double value and in particular - as shown in Fig. 4 - at least the triple value of the mean seal width b_u . All other values as the first and second base areas A_1 , A_2 and their relationships to each other may be analogously derived as done along with the unfilled state according to Fig. 3.

[0031] The outer diameter of the cleaning agent product or its respective base area A_3 is in particular in a range from 55,0 mm, inclusive, to 75,0 mm, inclusive, and preferably in a range from 60,0 mm, inclusive, to 70,0 mm, inclusive. In the shown preferred embodiment, said outer diameter is at least approximately 64,5 mm. Both the seal width of the outer sealed joint 15 and the strip width b_s are in particular in a range from 3,0 mm, inclusive, to 5,0 mm, inclusive, and preferably in a range from 3,5 mm, inclusive, to 4,5 mm, inclusive. In the shown preferred embodiment, said seal width and said strip width b_s are at least approximately 4,0 mm. The outer sealed joint 15 has a radial distance to the outer circumferential contour of cleaning agent product or its respective base area A_3 of at least approximately 1,0 mm. The seal width b_s is in particular in a range from 1,4 mm, inclusive, to 2,6 mm, inclusive, and preferably in a range from 1,7 mm, inclusive, to 2,3 mm, inclusive. In the shown preferred embodiment, said seal width b_s is at least approximately 2,0 mm.

[0032] Fig. 5 shows a side view of the cleaning agent product 10 according of Figs. 1 to 4 with details of the deep drawn base foil 5. It can be seen, that the surrounding side walls of the two chambers 1, 2 are deep drawn with respect to the flange 14 and the perpendicular line thereto with a draft angle α preferably being $\leq 7^\circ$, and being in the shown preferred embodiment at least approximately 5° .

[0033] Fig. 6 shows a cross sectional view of the cleaning agent product 10 according to Fig. 5 along the cross section line V-V of Figs. 3 and 4. Only the base foil 5 is deep drawn to form the first chamber 1 and the second chamber 2. The lid foil 6, which is sealed closely onto the base foil 5 on the flange 14 and on the separating strip 9 in a non-intermittent way along the sealed joints 11, 15 (Fig. 1) is not deep drawn or plastically deformed in any other way. The shown upward deflection of the lid foil 6 is an elastic deflection due to the internal pressure of the third cleaning agent 3 and the second cleaning agent 4. With respect to the flange 14 and the coplanar separating strip 9, the first chamber 1 is deep drawn to a first chamber depth t_1 , while the second chamber 2 is deep drawn to a second chamber depth t_2 . In the shown preferred embodiment, the first chamber depth t_1 is at least approximately 18,7 mm, while the second chamber depth t_2 is at least approximately 15,7 mm. The base areas A_1 , A_2 ,

the related chamber depth t_1 , t_2 and the cross sectional shape of the chambers 1, 2 lead to a first volume V_1 of the first chamber 1 and to a second volume V_2 of the second chamber 2. In the shown preferred embodiment, the first volume V_1 is at least approximately 17,61 ml, while the second volume V_2 is at least approximately 7,72 ml. In addition it can be seen, that besides the outer walls according to Fig. 5 the chamber walls of the two chambers 1, 2 facing each other in the area of the separating strip 9 are deep drawn with a draft angle $\alpha \leq 7^\circ$ and in particular - as shown - being at least approximately 5° .

[0034] The quotient of the first volume V_1 and the second volume V_2 is preferably in a range from 1,8, inclusive, to 2,8, inclusive, and in particular in a range from 2,1, inclusive, to 2.5, inclusive. In the shown preferred embodiment said ratio is at least approximately 2,3. The smaller one of the two depths t_1 , t_2 , which is in the shown embodiment the second chamber depth t_2 is greater than the mean strip width b_s (Fig. 3) at least by the factor of 3 and in particular a least approximately greater than the mean strip width b_s by the factor of 4. In addition, it is greater than the mean seal width b_u (Fig. 4) at least by the factor of 6, and in particular at least approximately greater than the mean seal width b_u by the factor of 8.

[0035] The base foil 5 and/or the lid foil 6, in the shown embodiment both the base foil 5 and the lid foil 6 have a thickness being preferably in a range from 50 μm , inclusive, to 100 μm , inclusive, and in particular in a range from 60 μm , inclusive, to 90 μm , inclusive. In the shown preferred embodiment, said thickness is at least approximately 76 μm , which applies for both the base foil 5 and the lid foil 6. However, deviating foil thicknesses may be chosen. The lid foil 6 may also have a different, in particular a smaller thickness compared to the thickness of the base foil 5.

[0036] Due to the above mentioned geometric limitations the entire inventive cleaning agent product has a strong geometric form stability despite the small foil thicknesses and the elastic separating strip 9 between the two chambers 1, 2. The cleaning agent product is easy to manufacture with low machine and material cost, and can be easily handled by the user.

Claims

1. Cleaning agent product, comprising a water soluble pouch (10) having a first chamber (1) and a second chamber (2) being separated from the first chamber (1), wherein the first chamber (1) and the second chamber (2) are each filled with a cleaning agent (3, 4), wherein the pouch (10) is made of a water soluble base foil (5) and of a water soluble lid foil (6) being tightly connected to each other, wherein the base foil (5) is deep drawn in a plastically deforming manner to form the first chamber (1) and the second chamber (2), wherein the first chamber (1) comprises a first base area (A_1), the second chamber (2) a sec-

ond base area (A_2) and the entire cleaning agent product a third base area (A_3), wherein the first base area (A_1) of the first chamber (1) comprises a concave section (7) on its side facing the second chamber (2), wherein the second base area (A_2) of the second chamber (2) comprises a convex section (8) on its side facing the first chamber (1), wherein the convex section (8) of the second chamber (2) extends into the concave section (7) of the first chamber (1),

characterized in that the second base area (A_2) of the second chamber (2) has aside to its convex section (8) at least one concave section (13) adjacent to at least one convex section (12) of the first base area (A_1), and that the third base area (A_3) of the cleaning agent product is at least approximately circular shaped.

2. Cleaning agent product according to claim 1, **characterized in that** between the first chamber (1) and the second chamber (2) a separating strip (9) is present having a mean strip width (b_s), that the convex section (8) of the second chamber (2) extends into the concave section (7) of the first chamber (1) by a first extension width (b_{t1}) related to the mean strip width (b_s), and that the first extension width (b_{t1}) is at least approximately equal to or greater than the mean strip width (b_s).

3. Cleaning agent product according to claim 1 or 2, **characterized in that** between the first chamber (1) and the second chamber (2) a separating strip (9) is present providing along the separating strip (9) a sealed joint (11) with a mean seal width (b_u) to tightly connect the lid foil (6) to the base foil (5), that the convex section (8) of the second chamber (2) extends into the concave section (7) of the first chamber (1) by a second extension width (b_{t2}) related to the mean seal width (b_u), and that the second extension width (b_{t2}) has at least the double value, in particular at least the triple value of the mean seal width (b_u).

4. Cleaning agent product according to claim 2 or 3, **characterized in that** the separating strip (9) and/or the sealed joint (11) have at least along the major part of their length a constant strip width (b_s) and/or a constant seal width (b_u) respectively.

5. Cleaning agent product according to one of claims 2 to 4, **characterized in that** the first chamber (1) has a first depth (t_1), that the second chamber (2) has a second depth (t_2), and that the smaller one of the two depths (t_1 , t_2) is greater than the mean strip width (b_s) at least by the factor of three, and in particular is at least approximately greater than the mean strip width (b_s) by the factor of four.

6. Cleaning agent product according to one of claims 3 to 5,
characterized in that the first chamber (1) has a first depth (t_1), that the second chamber (2) has a second depth (t_2), and that the smaller one of the two depths (t_1, t_2) is greater than the mean seal width (b_u) at least by the factor of six, and in particular is at least approximately greater than the mean seal width (b_u) by the factor of eight.
7. Cleaning agent product according to one of claims 1 to 6,
characterized in that the first chamber (1) and/or the second chamber (2) have at least at their side facing the respective other chamber (2, 1) a wall section with a draft angle (α) being $\leq 7^\circ$ and in particular being at least approximately 5° .
8. Cleaning agent product according to one of claims 1 to 7,
characterized in that the second base area (A_2) of the second chamber (2) has aside to its convex section (8) two mirror symmetrically disposed concave sections (13) adjacent to two mirror symmetrically disposed convex sections (12) of the first base area (A_1).
9. Cleaning agent product according to one of claims 1 to 8,
characterized in that the quotient of the first base area (A_1) and the second base area (A_2) is in a range from 1,4, inclusive, to 2,4, inclusive, preferably in a range from 1,7, inclusive, to 2,1, inclusive, and is in particular at least approximately 1,9.
10. Cleaning agent product according to one of claims 1 to 9,
characterized in that the first chamber (1) has a first volume (V_1), that the second chamber has a second volume (V_2), and that the quotient of the first volume (V_1) and the second volume (V_2) is in a range from 1,8, inclusive, to 2,8, inclusive, preferably in a range from 2,1, inclusive, to 2,5, inclusive, and is in particular at least approximately 2,3.
11. Cleaning agent product according to one of claims 1 to 10,
characterized in that the base foil (5) only and not the lid foil (6) is deep drawn to form the first chamber (1) and the second chamber (2).
12. Cleaning agent product according to one of claims 1 to 11,
characterized in that the base foil (5) and/or the lid foil (6) have a thickness being in a range from 50 μm , inclusive, to 100 μm , inclusive, preferably in a range from 60 μm , inclusive, to 90 μm , inclusive, and being in particular at least approximately 76 μm .

Patentansprüche

1. Reinigungsmittelprodukt, umfassend einen wasserlöslichen Beutel (10) mit einer ersten Kammer (1) und einer von der ersten Kammer (1) getrennten zweiten Kammer (2), wobei die erste Kammer (1) und die zweite Kammer (2) jeweils mit einem Reinigungsmittel (3, 4) gefüllt sind, wobei der Beutel (10) aus einer wasserlöslichen Basisfolie (5) und einer wasserlöslichen Deckfolie (6) gefertigt ist, die dicht miteinander verbunden sind, wobei die Basisfolie (6) zur Bildung der ersten Kammer (1) und der zweiten Kammer (2) in plastisch verformender Weise tiefgezogen ist, wobei die erste Kammer (1) eine erste Basisfläche (A_1), die zweite Kammer (2) eine zweite Basisfläche (A_2) und das gesamte Reinigungsmittelprodukt eine dritte Basisfläche (A_3) aufweist, wobei die erste Basisfläche (A_1) der ersten Kammer (1) auf ihrer der zweiten Kammer (2) zugewandten Seite einen konkaven Abschnitt (7) aufweist, wobei die zweite Basisfläche (A_2) der zweiten Kammer (2) auf ihrer der ersten Kammer (1) zugewandten Seite einen konvexen Abschnitt (8) aufweist, wobei der konvexe Abschnitt (8) der zweiten Kammer (2) in den konkaven Abschnitt (7) der ersten Kammer (1) hineinreicht, **dadurch gekennzeichnet, dass** die zweite Basisfläche (A_2) der zweiten Kammer (2) seitlich ihres konvexen Abschnittes (8) zumindest einen konkaven Abschnitt (13) aufweist, der an zumindest einen konvexen Abschnitt (12) der ersten Basisfläche (A_1) angrenzt, und dass die dritte Basisfläche (A_3) des Reinigungsmittelproduktes zumindest näherungsweise kreisförmig ist.
2. Reinigungsmittelprodukt nach Anspruch 1, **dadurch gekennzeichnet, dass** zwischen der ersten Kammer (1) und der zweiten Kammer (2) ein Trennstreifen (9) mit einer mittleren Streifenbreite (b_s) vorhanden ist, dass sich der konvexe Abschnitt (8) der zweiten Kammer (2) bezogen auf die mittlere Streifenbreite (b_s) mit einer ersten Erstreckungstiefe (b_{t1}) in den konkaven Abschnitt (7) der ersten Kammer (2) erstreckt, und dass die erste Erstreckungstiefe (b_{t1}) zumindest näherungsweise gleich oder größer als die mittlere Streifenbreite (b_s) ist.
3. Reinigungsmittelprodukt nach Anspruch 1 oder 2, **dadurch gekennzeichnet, dass** zwischen der ersten Kammer (1) und der zweiten Kammer (2) ein Trennstreifen (9) vorhanden ist, der entlang des Trennstreifens (9) eine Siegelnaht mit einer mittleren Siegelbreite (b_u) zur dichten Verbindung der Deckfolie (6) mit der Basisfolie (5) bildet, dass sich der konvexe Abschnitt (8) der zweiten Kammer (2) bezogen auf die mittlere Siegelbreite (b_u) mit einer zweiten Erstreckungstiefe (b_{t2}) in den konkaven Abschnitt (7) der ersten Kammer (2) erstreckt, und dass die zweite Erstreckungstiefe (b_{t2}) mindestens den

doppelten Wert, insbesondere mindestens den dreifachen Wert der mittleren Siegelbreite (b_u) hat.

4. Reinigungsmittelprodukt nach Anspruch 2 oder 3, **dadurch gekennzeichnet, dass** der Trennstreifen (9) und/oder die Siegelnaht (11) zumindest entlang des größeren Teils ihrer Länge eine konstante Streifenbreite (b_s) und bzw. oder eine konstante Siegelbreite (b_u) haben.
5. Reinigungsmittelprodukt nach einem der Ansprüche 2 bis 4, **dadurch gekennzeichnet, dass** die erste Kammer (1) eine erste Tiefe (t_1) hat, dass die zweite Kammer (2) eine zweite Tiefe (t_2) hat, und dass die kleinere der zwei Tiefen (t_1 , t_2) um mindestens den Faktor drei größer ist als die mittlere Streifenbreite (b_s), und insbesondere zumindest näherungsweise um den Faktor vier größer ist als die mittlere Streifenbreite (b_s).
6. Reinigungsmittelprodukt nach einem der Ansprüche 3 bis 5, **dadurch gekennzeichnet, dass** die erste Kammer (1) eine erste Tiefe (t_1) hat, dass die zweite Kammer (2) eine zweite Tiefe (t_2) hat, und dass die kleinere der zwei Tiefen (t_1 , t_2) um mindestens den Faktor sechs größer ist als die mittlere Siegelbreite (b_u), und insbesondere zumindest näherungsweise um den Faktor acht größer ist als die mittlere Siegelbreite (b_u).
7. Reinigungsmittelprodukt nach einem der Ansprüche 1 bis 6, **dadurch gekennzeichnet, dass** die erste Kammer (1) und/oder die zweite Kammer (2) zumindest an ihrer der jeweiligen anderen Kammer (2, 1) zugewandten Seite einen Wandabschnitt aufweisen, dessen Tiefziehwinkel (α) $\leq 7^\circ$ ist und insbesondere zumindest näherungsweise 5° beträgt.
8. Reinigungsmittelprodukt nach einem der Ansprüche 1 bis 7, **dadurch gekennzeichnet, dass** die zweite Grundfläche (A_2) der zweiten Kammer (2) seitlich neben ihres konvexen Abschnittes (8) zwei spiegelsymmetrisch zueinander angeordnete konkave Abschnitte (13) aufweist, die an zwei spiegelsymmetrisch zueinander angeordnete konvexe Abschnitte (12) der ersten Grundfläche (A_1) angrenzen.
9. Reinigungsmittelprodukt nach einem der Ansprüche 1 bis 8, **dadurch gekennzeichnet, dass** das Verhältnis der ersten Grundfläche (A_1) zur zweiten Grundfläche (A_2) in einem Bereich von einschließlich 1,4 bis einschließlich 2,4 und bevorzugt in einem Bereich von einschließlich 1,7 bis einschließlich 2,1 liegt und ins-

besondere zumindest näherungsweise 1,9 beträgt.

10. Reinigungsmittelprodukt nach einem der Ansprüche 1 bis 9, **dadurch gekennzeichnet, dass** die erste Kammer (1) ein erstes Volumen (V_1) aufweist, dass die zweite Kammer (2) ein zweites Volumen (V_2) aufweist, und dass das Verhältnis des ersten Volumens (V_1) zum zweiten Volumen (V_2) in einem Bereich von einschließlich 1,8 bis einschließlich 2,8 und bevorzugt in einem Bereich von einschließlich 2,1 bis einschließlich 2,5 liegt und insbesondere zumindest näherungsweise 2,3 beträgt.
11. Reinigungsmittelprodukt nach einem der Ansprüche 1 bis 10, **dadurch gekennzeichnet, dass** nur die Basisfolie (5) und nicht die Deckfolie (6) zur Bildung der ersten Kammer (1) und der zweiten Kammer (2) tiefgezogen ist.
12. Reinigungsmittelprodukt nach einem der Ansprüche 1 bis 11, **dadurch gekennzeichnet, dass** die Basisfolie (5) und/oder die Deckfolie (6) eine Dicke aufweist, die in einem Bereich von einschließlich 50 μm bis einschließlich 100 μm und bevorzugt in einem Bereich von einschließlich 60 μm bis einschließlich 90 μm liegt und insbesondere zumindest näherungsweise 76 μm beträgt.

Revendications

1. Produit d'agent de nettoyage comprenant un sachet soluble dans l'eau (10) qui présente une première chambre (1) et une seconde chambre (2) séparée de ladite première chambre (1), étant précisé que la première chambre (1) et la seconde chambre (2) sont remplies chacune avec un agent de nettoyage (3, 4), que le sachet (10) se compose d'un film de base soluble dans l'eau (5) et d'un film formant couvercle soluble dans l'eau (6) reliés de manière étanche, que le film de base (5) est soumis à un étirage profond à la manière d'une déformation plastique, pour former la première chambre (1) et la seconde chambre (2), que la première chambre (1) comprend une première surface de base (A_1), la seconde chambre (2) une deuxième surface de base (A_2), et tout le produit d'agent de nettoyage une troisième surface de base (A_3), que la première zone de base (A_1) de la première chambre (1) comprend une section concave (7) sur son côté tourné vers la seconde chambre (2), que la deuxième surface de base (A_2) de la seconde chambre (2) comprend une section convexe (8) sur son côté tourné vers la première chambre (1), que la section convexe (8) de la seconde chambre (2) s'étend jusque dans la section con-

- cave (7) de la première chambre (1),
caractérisé en ce que la deuxième surface de base (A_2) de la seconde chambre (2) présente, sur le côté de sa section convexe (8), au moins une section concave (13) voisine d'au moins une section convexe (12) de la première surface de base (A_1), et **en ce que** la troisième surface de base (A_3) du produit d'agent de nettoyage a une forme au moins approximativement circulaire.
2. Produit d'agent de nettoyage selon la revendication 1,
caractérisé en ce qu'il y a entre la première chambre (1) et la seconde chambre (2) une bande de séparation (9) qui présente une largeur de bande moyenne (b_s), **en ce que** la section convexe (8) de la seconde chambre (2) s'étend jusque dans la section concave (7) de la première chambre (1) sur une première largeur d'extension (b_{t1}) par rapport à la largeur de bande moyenne (b_s), et **en ce que** la première largeur d'extension (b_{t1}) est au moins approximativement égale ou supérieure à la largeur de bande moyenne (b_s).
3. Produit d'agent de nettoyage selon la revendication 1 ou 2,
caractérisé en ce qu'il y a entre la première chambre (1) et la seconde chambre (2) une bande de séparation (9), ce qui forme le long de ladite bande de séparation (9) un joint hermétique (11) d'une largeur de joint moyenne (b_u) pour relier hermétiquement le film formant couvercle (6) au film de base (5), **en ce que** la section convexe (8) de la seconde chambre (2) s'étend jusque dans la section concave (7) de la première chambre (1) sur une seconde largeur d'extension (b_{t2}) par rapport à la largeur de joint moyenne (b_u), et **en ce que** la seconde largeur d'extension (b_{t2}) est égale à au moins deux fois, en particulier à au moins trois fois la largeur de joint moyenne (b_u).
4. Produit d'agent de nettoyage selon la revendication 2 ou 3,
caractérisé en ce que la bande de séparation (9) et/ou le joint hermétique (11) présentent, au moins sur la majeure partie de leur longueur, une largeur de bande (b_s) constante et/ou une largeur de joint (b_u) constante, respectivement.
5. Produit d'agent de nettoyage selon l'une des revendications 2 à 4,
caractérisé en ce que la première chambre (1) a une première profondeur (t_1), **en ce que** la seconde chambre (2) a une seconde profondeur (t_2), et **en ce que** la plus petite des deux profondeurs (t_1 , t_2) est supérieure d'au moins un facteur trois à la largeur de bande moyenne (b_s), et est en particulier au moins approximativement supérieure d'un facteur quatre à la largeur de bande moyenne (b_s).
6. Produit d'agent de nettoyage selon l'une des revendications 3 à 5,
caractérisé en ce que la première chambre (1) a une première profondeur (t_1), **en ce que** la seconde chambre (2) a une seconde profondeur (t_2), et **en ce que** la plus petite des deux profondeurs (t_1 , t_2) est supérieure d'au moins un facteur six à la largeur de joint moyenne (b_u), et est en particulier au moins approximativement supérieure d'un facteur huit à la largeur de joint moyenne (b_u).
7. Produit d'agent de nettoyage selon l'une des revendications 1 à 6,
caractérisé en ce que la première chambre (1) et/ou la seconde chambre (2) ont, au moins sur leur côté tourné vers l'autre chambre (2, 1), une section de paroi avec un angle de dépouille (α) qui est $\leq 7^\circ$ et qui est en particulier au moins approximativement de 5° .
8. Produit d'agent de nettoyage selon l'une des revendications 1 à 7,
caractérisé en ce que la seconde surface de base (A_2) de la seconde chambre (2) présente, à côté de sa section convexe (8), deux sections concaves (13) disposées symétriquement en miroir et voisines de deux sections convexes (12), disposées symétriquement en miroir, de la première surface de base (A_1).
9. Produit d'agent de nettoyage selon l'une des revendications 1 à 8,
caractérisé en ce que le quotient de la première surface de base (A_1) et de la seconde surface de base (A_2) est situé dans une plage de 1,4 inclus à 2,4 inclus, de préférence dans une plage de 1,7 inclus à 2,1 inclus, et est en particulier au moins approximativement de 1,9.
10. Produit d'agent de nettoyage selon l'une des revendications 1 à 9,
caractérisé en ce que la première chambre (1) a un premier volume (V_1), **en ce que** la seconde chambre a un second volume (V_2) et **en ce que** le quotient du premier volume (V_1) et du second volume (V_2) est situé dans une plage de 1,8 inclus à 2,8 inclus, de préférence dans une plage de 2,1 inclus à 2,5 inclus, et est en particulier au moins approximativement de 2,3.
11. Produit d'agent de nettoyage selon l'une des revendications 1 à 10,
caractérisé en ce que le film de base (5) seul, et pas le film formant couvercle (6), est soumis à un étirage profond pour former la première chambre (1) et la seconde chambre (2).
12. Produit d'agent de nettoyage selon l'une des revendications 1 à 11,

caractérisé en ce que le film de base (5) et/ou le film formant couvercle (6) ont une épaisseur qui est située dans une plage de 50 μm inclus à 100 μm inclus, de préférence dans une plage de 60 μm inclus à 90 μm inclus, et qui est en particulier au moins approximativement de 76 μm .

5

10

15

20

25

30

35

40

45

50

55

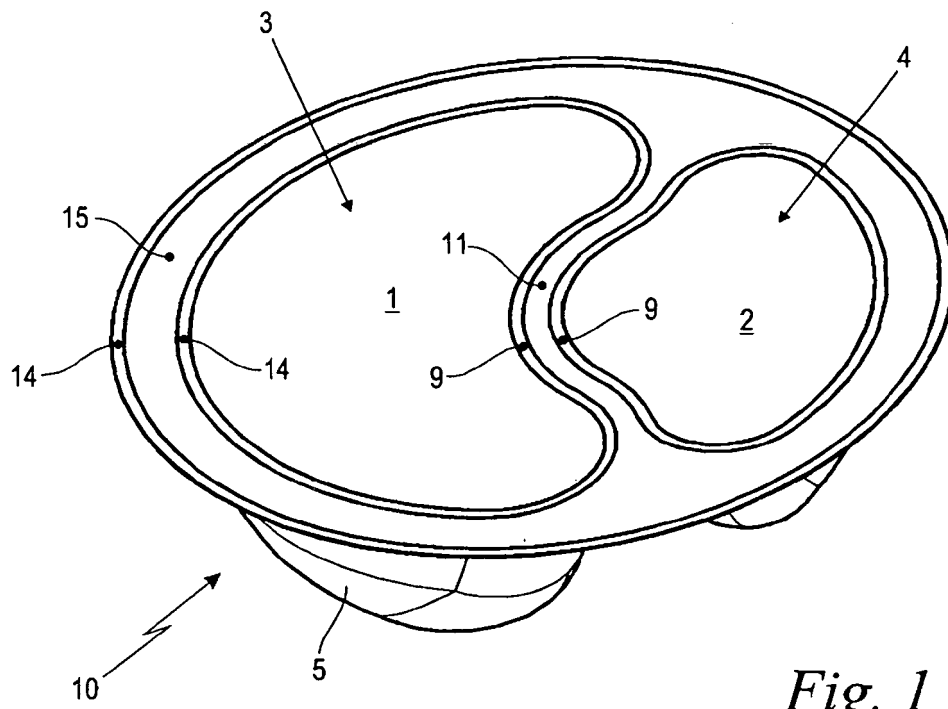

Fig. 1

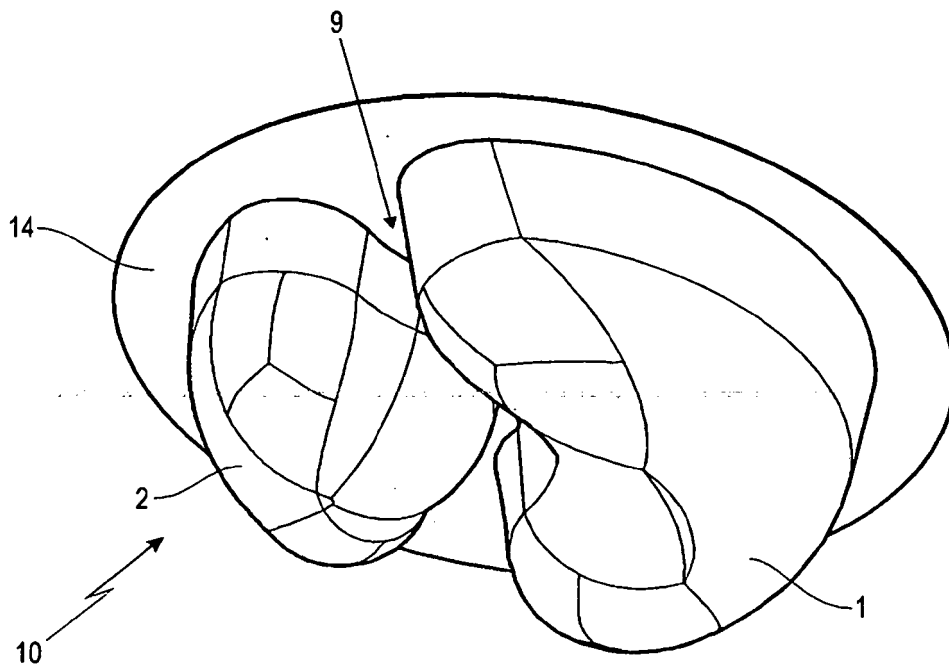

Fig. 2

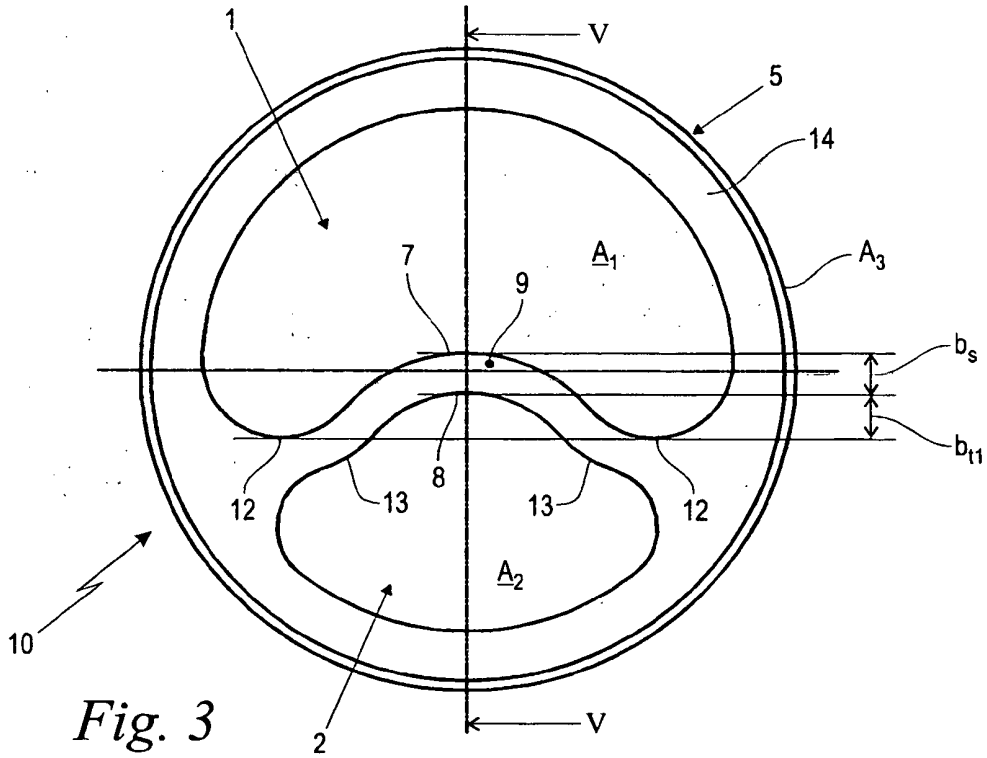

Fig. 3

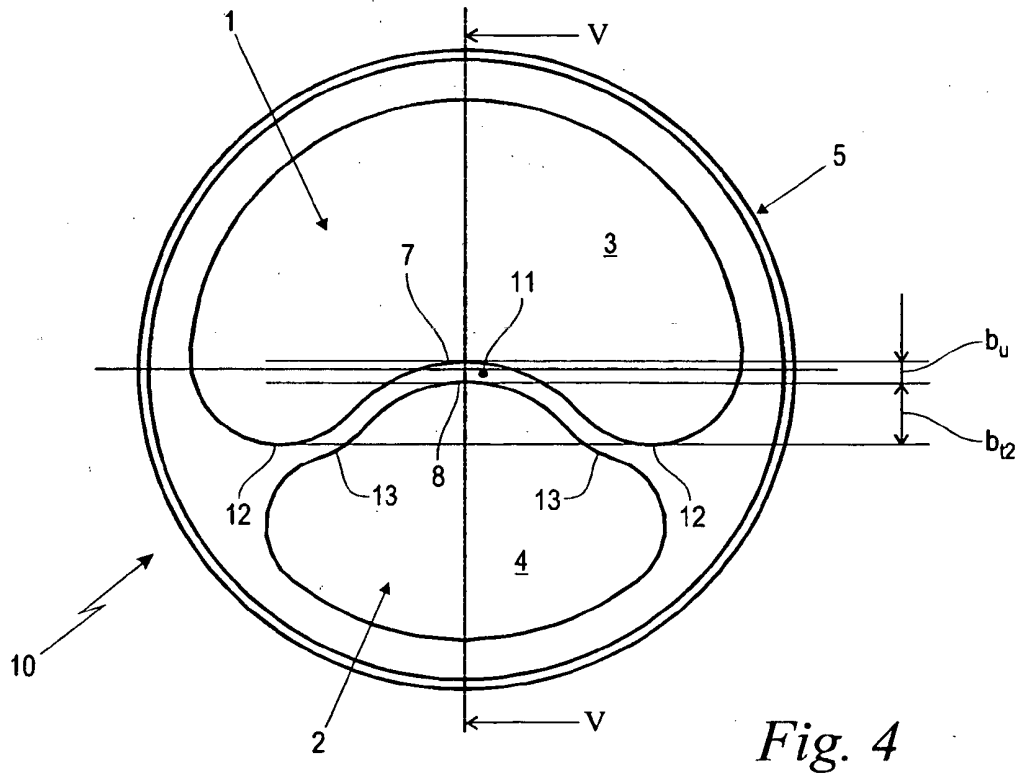

Fig. 4

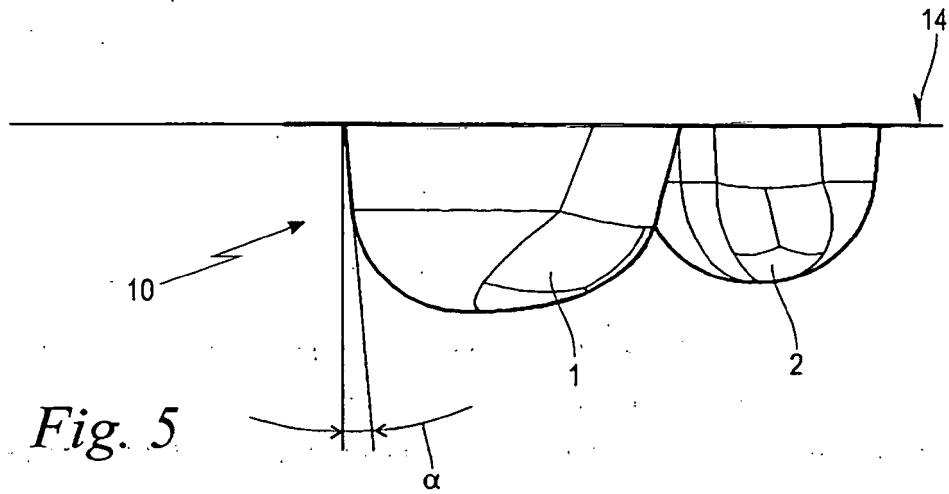

Fig. 5

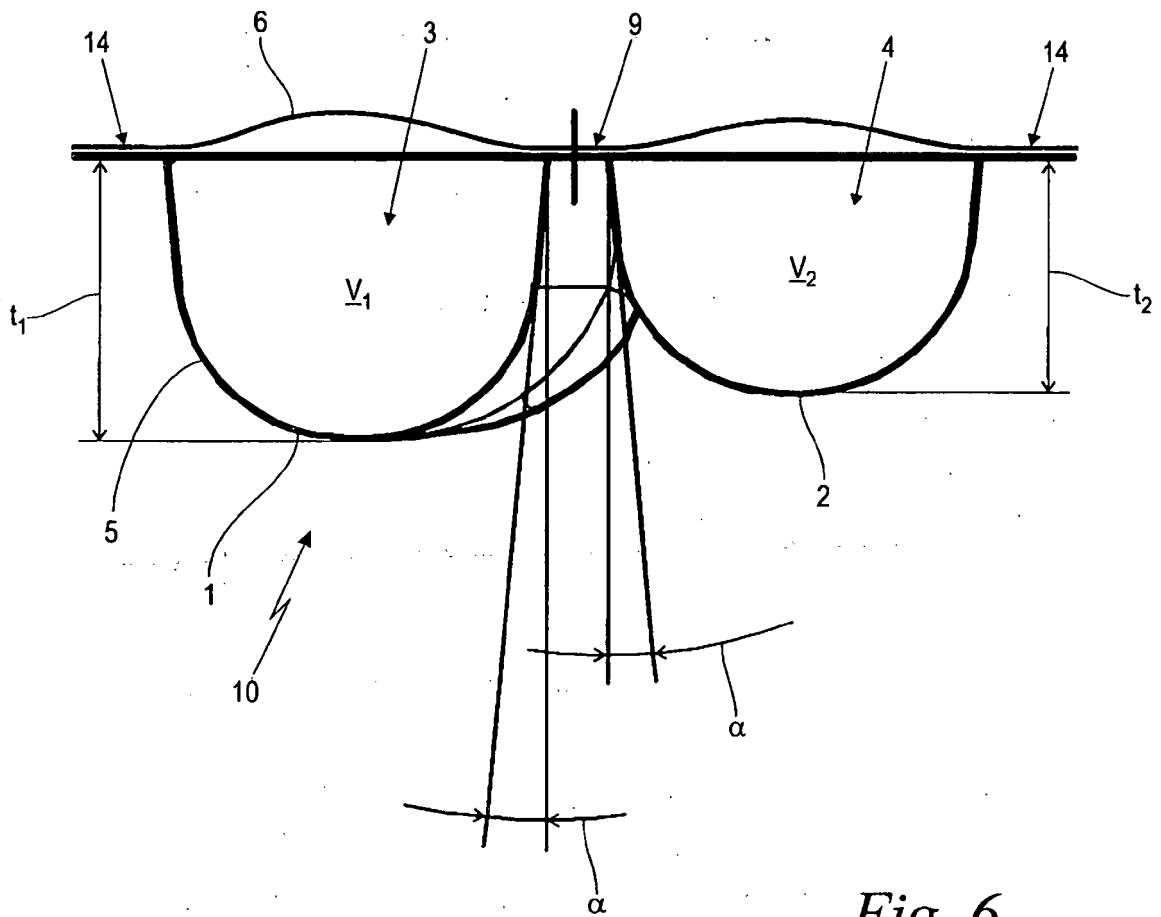

Fig. 6

REFERENCES CITED IN THE DESCRIPTION

This list of references cited by the applicant is for the reader's convenience only. It does not form part of the European patent document. Even though great care has been taken in compiling the references, errors or omissions cannot be excluded and the EPO disclaims all liability in this regard.

Patent documents cited in the description

- EP 1375637 A1 [0007]