



(11) **EP 2 626 517 B1**

(12) **EUROPEAN PATENT SPECIFICATION**

(45) Date of publication and mention of the grant of the patent:  
**01.04.2020 Bulletin 2020/14**

(51) Int Cl.:  
**F01D 5/22** <sup>(2006.01)</sup> **F01D 11/12** <sup>(2006.01)</sup>  
**F01D 11/08** <sup>(2006.01)</sup> **F01D 5/30** <sup>(2006.01)</sup>

(21) Application number: **13154014.8**

(22) Date of filing: **05.02.2013**

(54) **Rotating assembly for a turbine assembly**

Rotierende Anordnung für eine Turbinenanordnung

Ensemble rotatif pour un ensemble de turbine

(84) Designated Contracting States:  
**AL AT BE BG CH CY CZ DE DK EE ES FI FR GB GR HR HU IE IS IT LI LT LU LV MC MK MT NL NO PL PT RO RS SE SI SK SM TR**

(30) Priority: **08.02.2012 US 201213368931**

(43) Date of publication of application:  
**14.08.2013 Bulletin 2013/33**

(73) Proprietor: **General Electric Company Schenectady, NY 12345 (US)**

(72) Inventors:  
• **Bruce, Kevin Leon Greenville, SC South Carolina 29615 (US)**

- **Cairo, Ronald Ralph Greenville, SC South Carolina 29615 (US)**
- **Piersall, Matthew Robert Greenville, SC South Carolina 29615 (US)**
- **Rollings, Richard Gordon Greenville, SC South Carolina 29615 (US)**

(74) Representative: **BRP Renaud & Partner mbB Rechtsanwälte Patentanwälte Steuerberater Königstraße 28 70173 Stuttgart (DE)**

(56) References cited:  
**WO-A1-2011/009430 US-A- 6 164 916**  
**US-A1- 2005 191 182 US-A1- 2009 202 344**

**EP 2 626 517 B1**

Note: Within nine months of the publication of the mention of the grant of the European patent in the European Patent Bulletin, any person may give notice to the European Patent Office of opposition to that patent, in accordance with the Implementing Regulations. Notice of opposition shall not be deemed to have been filed until the opposition fee has been paid. (Art. 99(1) European Patent Convention).

## Description

### BACKGROUND OF THE INVENTION

**[0001]** The subject matter disclosed herein relates to turbine systems, and more particularly to tip shrouds.

**[0002]** Turbine systems employ a number of rotating components or assemblies, such as compressor stages and turbine stages that rotate at high speed when the turbine is in operation, for example. In general, a stage includes a plurality of free-floating blades that extend radially outward from a central hub. Some blades include a shroud that limits vibration within a stage. The shroud is typically positioned at a tip portion of the blade, a mid portion of the blade or at both the mid portion and the tip portion of the blade. The shrouds are designed such that at high or operational speeds, the free-floating blades interlock to form an integral rotating member, however, even at lower speeds and possibly even when starting from a starting position at 0 rpm, the blades may interlock. During blade interlock, wear occurs due to slip when the tip portions are interlocked. At lower speeds, such as on turbine turning gear, the blades may not interlock and will often times impact one another. Impacts between the blades can cause damage that will shorten service life of the turbomachine.

**[0003]** In order to minimize damage resulting from blade impacts, a hard face coating is applied to potential contact points. The hard face coating increases wear resistance that may occur during operation of the blades and also increases the durability of potential contact points that may be susceptible to impacts. Conventionally, the hard face coating is metallurgically bonded to the blade through, for example, a welding, brazing or spraying process. Using a welding process to bond the hard face interface to the blade inherently produces a great deal of localized heat which, if not properly controlled, can weaken the wear and impact resistance and other metallurgical properties at the interface of the materials being joined. Excessive heat can also cause cracking in adjacent material during manufacture.

**[0004]** US6164916A discloses a method in which a hard facematerial is diffusion bonded to a turbine blade shroud. Document WO 2011/009430 A1 discloses a shrouded turbine blade made of TiAl alloy and comprising a hard protective body brazed to a contact surface of the shroud. The arrangement may comprise an intermediate material layer between the shroud and the protective body to improve bonding.

### BRIEF DESCRIPTION OF THE INVENTION

**[0005]** According to the invention, a rotating assembly for a turbine assembly is provided, as set forth in claim 1.

**[0006]** According to an embodiment of the above rotating assembly, the substrate may include a plurality of grooved portions. Yet further the at least one hard face interface member may be both mechanically interlocked

with, and metallurgically bonded to the substrate.

**[0007]** These and other advantages and features will become more apparent from the following description taken in conjunction with the drawings.

### BRIEF DESCRIPTION OF THE DRAWING

**[0008]** Embodiments of the present invention will now be described, by way of example only, with reference to the accompanying drawings in which:

FIG. 1 is a partial, cross-sectional schematic view of a turbomachine including a rotating assembly;

FIG. 2 is a partial perspective view of a rotating assembly including a plurality of rotating components;

FIG. 3 is a front perspective view of a tip shroud of a first embodiment;

FIG. 4 is a rear, elevational view of the tip shroud of FIG. 3;

FIG. 5 is a perspective view of a substrate having a plurality of substantially "U" shaped grooves;

FIG. 6 is a perspective view of a substrate having a plurality of "V" shaped grooves; and

FIG. 7 is a front perspective view of a tip shroud of a second embodiment.

**[0009]** The detailed description explains embodiments of the invention, together with advantages and features, by way of example with reference to the drawings.

### DETAILED DESCRIPTION OF THE INVENTION

**[0010]** Referring to FIG. 1, a turbomachine, shown in the form of a gas turbine engine, constructed in accordance with an exemplary embodiment of the present invention is indicated generally at 10. The engine 10 includes a compressor 12 and a plurality of combustor assemblies arranged in a can annular array, one of which is indicated at 14. As shown, the combustor assembly 14 includes an endcover assembly 16 that seals, and at least partially defines, a combustion chamber 18. A plurality of nozzles 20-22 are supported by the endcover assembly 16 and extend into the combustion chamber 18. The nozzles 20-22 receive fuel through a common fuel inlet (not shown) and compressed air from the compressor 12. The fuel and compressed air are passed into the combustion chamber 18 and ignited to form a high temperature, high pressure combustion product or air stream that is used to drive a turbine 24. The turbine 24 includes a plurality of rotating assemblies or stages 26-28 that are operationally connected to the compressor 12 through a compressor/turbine shaft 30 (sometimes re-

ferred to as a rotor).

**[0011]** In operation, air flows into the compressor 12 and is compressed into a high pressure gas. The high pressure gas is supplied to the combustor assembly 14 and mixed with fuel, for example process gas and/or synthetic gas (syngas), in the combustion chamber 18. The fuel/air or combustible mixture ignite to form a high pressure, high temperature combustion gas stream of approximately 538 degrees Celsius (°C) to 1593 °C (1000 degrees Fahrenheit (°F) to 2900 °F). Alternatively, the combustor assembly 14 can combust fuels that include, but are not limited to, natural gas and/or fuel oil. In any event, the combustor assembly 14 channels the combustion gas stream to the turbine 24 which converts thermal energy to mechanical, rotational energy.

**[0012]** At this point, it should be understood that each rotating assembly or stage 26-28 is similarly formed, thus reference will be made to FIG. 2 in describing stage 26 constructed in accordance with an exemplary embodiment of the present invention with an understanding that the remaining stages, i.e., stages 27 and 28, have corresponding structure. Also, it should be understood that the present invention could be employed in stages in the compressor 12 or other rotating assemblies that require wear and/or impact resistant surfaces. In any event, the stage 26 is shown to include a plurality of rotating members, such as an airfoil 32, which each extend radially outward from a central hub 34 having an axial centerline 35. The airfoil 32 is rotatable about the axial centerline 35 of the central hub 34 and includes a base portion 36 and a tip portion 38.

**[0013]** The tip shroud 50 covers a bucket or throat portion (not separately labeled) of airfoil 32. The tip shroud 50 is designed to receive, or nest with, tip shrouds on adjacent rotating members in order to form a continuous ring that extends circumferentially about the stage 26. The continuous ring creates an outer flow path boundary that reduces gas path air leakage over top portions (not separately labeled) of the stage 26, so as to increase stage efficiency and overall turbine performance. In the exemplary embodiment shown, during high or operational speeds, adjacent airfoils 32 interlock through their respective tip-shrouds 50 by virtue of centrifugal forces created by the operation of the turbine 24. It should be noted that interlock may occur even at extremely low speed operation, such that wearing due to slipping of the blades may occur due to operation during interlock. However, during lower speeds such as, during turbine turning gear, the rotational force may not be sufficient to establish the interlock and thus, adjacent rotating members may impact one another. The impacts can create wear on the rotating members thereby lowering an overall service life of the turbine 24. Additionally, operator handling at several manufacturing and assembly stages may result in such impacts. Towards that end, tip shroud 50 is provided with a wear resistant/impact resistant member in a manner that will be described more fully below.

**[0014]** Referring to FIGS. 3 and 4, the tip shroud 50

includes a tip blade 52 that extends generally along a top surface 54 of the tip shroud 50. The tip blade 52 is comprised of a first surface 56 and an opposing second surface 58, as well as a first edge 60 and a second edge 62. In the exemplary embodiment illustrated, the tip blade 52 also includes one or more cutter members, such as a first cutter member 64 and a second cutter member 66. The first cutter member 64 is disposed proximate the first edge 60 of the tip blade 52 and on the second surface 58, while the second cutter member 66 is disposed proximate the second edge 62 and on the first surface 56. Both the first and second cutter members 64, 66 are configured to engage a counterpart surface. An example of such a counterpart surface is an inner surface of an outer casing (not illustrated), such as a honeycomb structure. Engagement of the first and second cutter members 64, 66 with the counterpart surface removes material from the counterpart surface to achieve a sealing arrangement proximate the outer area of the stage 26.

**[0015]** Referring to FIGS. 5 and 6, a substrate 70 is operably coupled to the tip shroud 50 and includes a mechanical interlock pattern 72. In the illustrated embodiments, the mechanical interlock pattern 72 is shown as simply a plurality of grooves 74, but it is to be appreciated that the mechanical interlock pattern 72 may be formed of a plurality of grooves, protrusions, or a combination thereof. The plurality of grooves 74 may take on a number of geometries including, but not limited to, grooves having a relatively "U" shape (FIG. 5) or "V" shape (FIG. 6), for example. The "U" and "V" shaped examples are merely illustrative of the various shapes that may be employed to form the plurality of grooves 74. Irrespective of the mechanical interlock pattern 72, and specifically the groove or protrusion arrangement, the arrangement provides an increased surface area for a hard face interface 80 to interlock with upon application, when compared to a merely flat surface.

**[0016]** Referring again to FIGS. 3 and 4, the substrate 70 is shown as providing an interface with the tip shroud 50 and the hard face interface 80. The substrate 70 provides retention and/or bonding function for the hard face interface 80 to the tip shroud 50. The hard face interface 80 is operably secured to the substrate 70 by welding or brazing, for example. As previously described, the mechanical interlock pattern 72 of the substrate 70 increases the surface area available to form the securement of the hard face interface 80 to the substrate 70, thereby enhancing structural integrity. The hard face interface 80 includes a base portion 82 and a plurality of edge portions 84. It is contemplated that the substrate 70 may be secured to the hard face interface 80 at the base portion 82 or at least one of the plurality of edge portions 84, or a combination thereof. The substrate 70 provides additional structural integrity to the hard face interface 80 by fully encapsulating the edge portions 84, such that the likelihood of damage to the hard face interface 80 due to a collision with other structures during operation, installation, or handling, is reduced. The hard face interface

80 may be formed of a pre-sintered preform (PSP) material, for example, but it is to be appreciated that various materials may be employed for differing applications of use.

**[0017]** Referring to FIG. 7, a tip shroud 50 similar to that illustrated in FIGS. 3 and 4 is shown. The tip shroud 50 of FIG. 7 includes a single cutter member 90 disposed proximate a central location between the first edge 60 and the second edge 62 of the tip blade 52. The cutter member 90 extends away from both the first surface 56 and the second surface 58, such that regardless of the deformation of the tip shroud 50, or tip blade 52, during operation, the cutter member 90 may function to remove material from the aforementioned counterpart surface, such as a honeycomb structure. In the illustrated embodiment, the substrate 70 is flared outward from the first surface 56 at a location proximate the second edge 62. Similarly, an additional substrate portion may be flared outward at various other locations, such as away from the second surface 58 at a location proximate the first edge 60.

**[0018]** While the invention has been described in detail in connection with only a limited number of embodiments, it should be readily understood that the invention is not limited to such disclosed embodiments. Rather, the invention can be modified to incorporate any number of variations, alterations, substitutions or equivalent arrangements not heretofore described, that are commensurate with the scope of the appended claims. Additionally, while various embodiments of the invention have been described, it is to be understood that aspects of the invention may include only some of the described embodiments. Accordingly, the invention is not to be seen as limited by the foregoing description, but is only limited by the scope of the appended claims.

## Claims

1. A rotating assembly (26-28) for a turbine assembly comprising:

an airfoil (32) extending radially outward from, and rotatable about, an axial centerline (35);  
a tip shroud (50) integrally connected proximate a radially outer tip (38) of the airfoil (32);  
a substrate (70) operably coupled to the tip shroud (50); and

at least one hard face interface member (80) secured to the substrate (70) and configured for interaction with a tip shroud of an adjacent airfoil, wherein the at least one hard face interface member (80) includes a base portion (82) and a plurality of edge portions (84), wherein a portion of the substrate (70) fully encapsulates the edge portions (84) of the at least one hard face interface member (80).

2. The rotating assembly of claim 1, the tip shroud (50) comprising:

a tip blade (52) having a first surface (56), a second surface (58) opposing the first surface (56), a first edge (60) and a second edge (62),  
a first cutter member (64) disposed proximate the first edge (60) and the second surface (58); and  
a second cutter member (66) disposed proximate the second edge (62) and the first surface (56).

3. The rotating assembly of claim 1 or 2, the tip shroud (50) comprising a relatively planar tip blade (52) having a first edge (60) and a second edge (62), wherein the substrate includes a fillet portion proximate at least one of the first edge (60) or the second edge (62).

4. The rotating assembly of any of claims 1 to 3, wherein the at least one hard face interface member (80) is formed from a pre-sintered preformed material.

5. The rotating assembly of any preceding claim, wherein the at least one hard face interface member (80) is both mechanically interlocked with, and metallurgically bonded to the substrate (70).

6. The rotating assembly of any preceding claim, wherein the substrate (70) includes a plurality of grooved portions (74).

7. The rotating assembly of claim 6, wherein the plurality of grooved portions (74) are relatively U-shaped.

8. The rotating assembly of claim 6, wherein the plurality of grooved portions (74) are relatively V-shaped.

9. The rotating assembly of any preceding claim, wherein the substrate (70) includes a plurality of protrusions.

10. The rotating assembly of any preceding claim, wherein the at least one hard face interface member (80) is brazed to the substrate (70).

## Patentansprüche

1. Rotierende Anordnung (26-28) für eine Turbinenanordnung, umfassend:

ein Schaufelblatt (32), welches sich radial von einer Mittelachse (35) aus nach außen erstreckt, und drehbar um diese ist;

- eine Spitzenummantelung (50), welche integral in der Nähe einer radial äußeren Spitze (38) des Schaufelblatts (32) verbunden ist;  
ein Substrat (70), welches funktionsfähig mit der Spitzenummantelung (50) gekoppelt ist; und  
mindestens ein Schnittstellenelement mit harter Oberfläche (80), welches an dem Substrat (70) befestigt ist und zum Zusammenwirken mit einer Spitzenummantelung eines benachbarten Schaufelblatts konfiguriert ist,  
wobei das mindestens eine Schnittstellenelement mit harter Oberfläche (80) einen Basisabschnitt (82) und eine Vielzahl von Randabschnitten (84) einschließt, wobei ein Abschnitt des Substrats (70) die Randabschnitte (84) des mindestens einen Schnittstellenelements mit harter Oberfläche (80) vollständig einkapselt.
2. Rotierende Anordnung nach Anspruch 1, wobei die Spitzenummantelung (50) umfasst:
- ein Spitzenschaufelblatt (52) mit einer ersten Oberfläche (56), einer der ersten Oberfläche (56) gegenüberliegenden zweiten Oberfläche (58), einem ersten Rand (60) und einem zweiten Rand (62),  
ein erstes Schneidelement (64), das in der Nähe des ersten Rands (60) und der zweiten Oberfläche (58) angeordnet ist; und  
ein zweites Schneidelement (66), das in der Nähe des zweiten Rands (62) und der ersten Oberfläche (56) angeordnet ist.
3. Rotierende Anordnung nach Anspruch 1 oder 2, wobei die Spitzenummantelung (50) ein relativ ebenes Spitzenschaufelblatt (52) mit einem ersten Rand (60) und einem zweiten Rand (62) umfasst, wobei das Substrat einen Verrundungsabschnitt in der Nähe mindestens eines der ersten Rands (60) oder des zweiten Rands (62) einschließt.
4. Rotierende Anordnung nach einem der Ansprüche 1 bis 3, wobei das mindestens eine Schnittstellenelement mit harter Oberfläche (80) aus einem vorgeformten, vorgeformten Material gebildet ist.
5. Rotierende Anordnung nach einem vorstehenden Anspruch, wobei das mindestens eine Schnittstellenelement mit harter Oberfläche (80) sowohl mechanisch mit dem Substrat (70) verkuppelt, als auch metallurgisch damit verbunden ist.
6. Rotierende Anordnung nach einem vorstehenden Anspruch, wobei das Substrat (70) eine Vielzahl von gerillten Abschnitten (74) einschließt.
7. Rotierende Anordnung nach Anspruch 6, wobei die
- Vielzahl von gerillten Abschnitten (74) relativ U-förmig sind.
8. Rotierende Anordnung nach Anspruch 6, wobei die Vielzahl von gerillten Abschnitten (74) relativ V-förmig sind.
9. Rotierende Anordnung nach einem vorstehenden Anspruch, wobei das Substrat (70) eine Vielzahl von Vorsprüngen einschließt.
10. Rotierende Anordnung nach einem vorstehenden Anspruch, wobei das mindestens eine Schnittstellenelement mit harter Oberfläche (80) an das Substrat (70) hartgelötet ist.

### Revendications

1. Ensemble rotatif (26-28) pour un ensemble de turbine comprenant :
- un profil aérodynamique (32) s'étendant radialement vers l'extérieur à partir, et pouvant tourner autour, d'une ligne centrale axiale (35) ;  
un carénage d'extrémité (50) relié de manière solidaire à proximité d'une extrémité radialement externe (38) du profil aérodynamique (32) ;  
un substrat (70) couplé de manière opérationnelle au carénage d'extrémité (50) ; et  
au moins un élément d'interface de face dure (80) fixé au substrat (70) et configuré pour une interaction avec un carénage d'extrémité d'un profil aérodynamique adjacent, dans lequel l'au moins un élément d'interface de face dure (80) inclut une partie de base (82) et une pluralité de parties de bord (84), dans lequel une partie du substrat (70) encapsule complètement les parties de bord (84) de l'au moins un élément d'interface de face dure (80).
2. Ensemble rotatif selon la revendication 1, le carénage d'extrémité (50) comprenant :
- une aube d'extrémité (52) ayant une première surface (56), une deuxième surface (58) opposée à la première surface (56), un premier bord (60) et un deuxième bord (62),  
un premier élément de coupe (64) disposé à proximité du premier bord (60) et de la deuxième surface (58) ; et  
un deuxième élément de coupe (66) disposé à proximité du deuxième bord (62) et de la première surface (56).
3. Ensemble rotatif selon la revendication 1 ou 2, le carénage d'extrémité (50) comprenant une aube

d'extrémité relativement plane (52) ayant un premier bord (60) et un deuxième bord (62), dans lequel le substrat inclut une partie de congé à proximité d'au moins l'un du premier bord (60) ou du deuxième bord (62).

5

4. Ensemble rotatif selon l'une quelconque des revendications 1 à 3, dans lequel l'au moins un élément d'interface de face dure (80) est formé à partir d'un matériau préformé préfritté. 10
5. Ensemble rotatif selon une quelconque revendication précédente, dans lequel l'au moins un élément d'interface de face dure (80) est à la fois mécaniquement imbriqué et lié de manière métallurgique avec le substrat (70). 15
6. Ensemble rotatif selon une quelconque revendication précédente, dans lequel le substrat (70) inclut une pluralité de parties rainurées (74). 20
7. Ensemble rotatif selon la revendication 6, dans lequel la pluralité de parties rainurées (74) sont relativement en forme de U. 25
8. Ensemble rotatif selon la revendication 6, dans lequel la pluralité de parties rainurées (74) sont relativement en forme de V.
9. Ensemble rotatif selon une quelconque revendication précédente, dans lequel le substrat (70) inclut une pluralité de parties saillantes. 30
10. Ensemble rotatif selon une quelconque revendication précédente, dans lequel l'au moins un élément d'interface de face dure (80) est brasé sur le substrat (70). 35

40

45

50

55

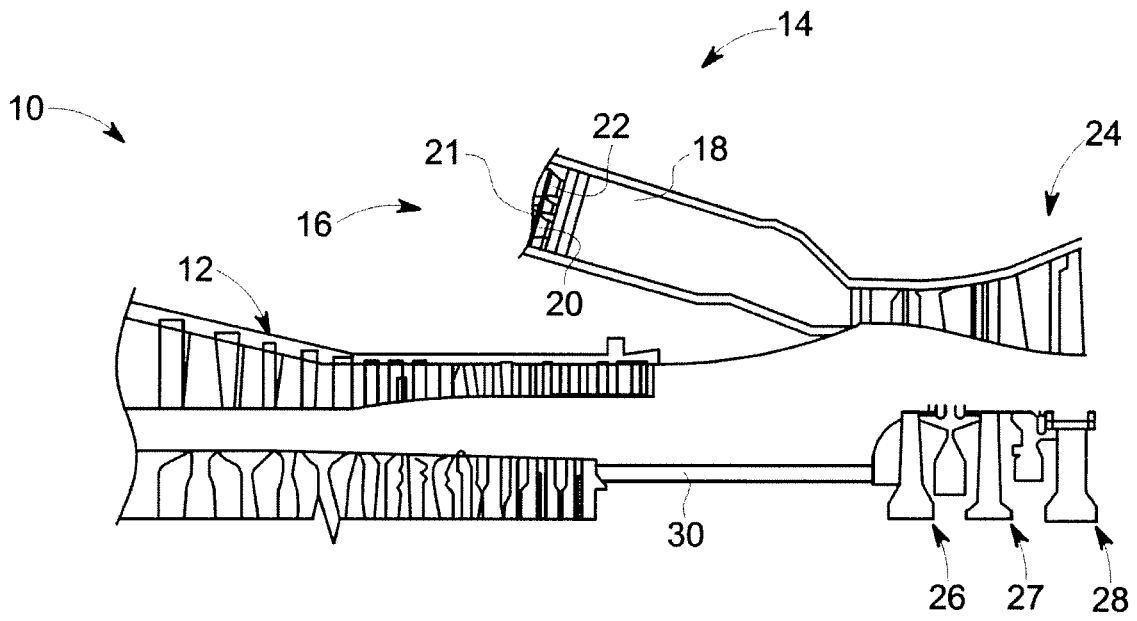

FIG. 1

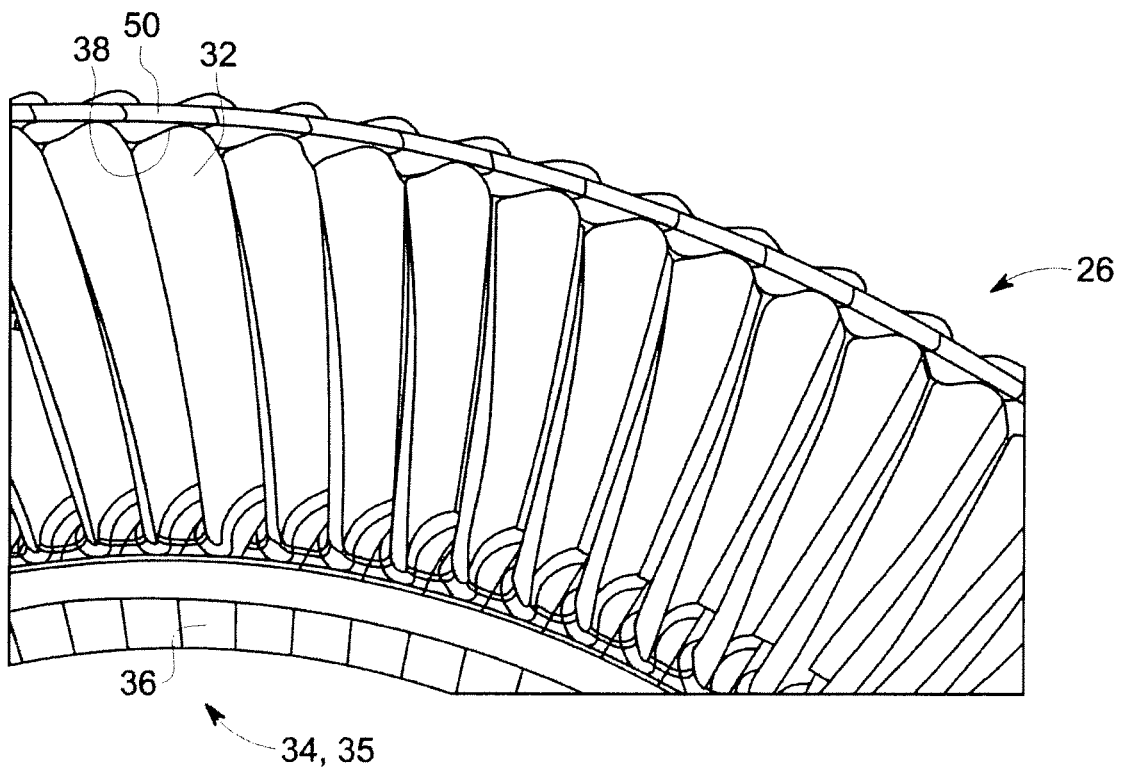

FIG. 2

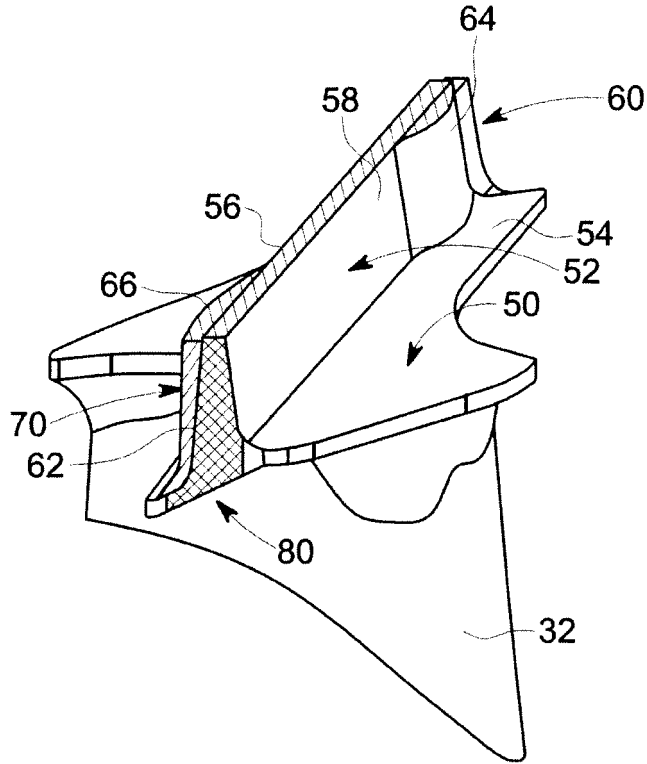

FIG. 3

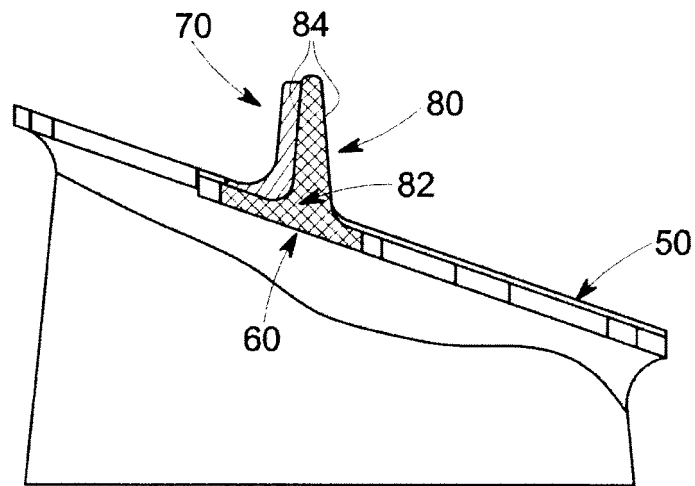

FIG. 4

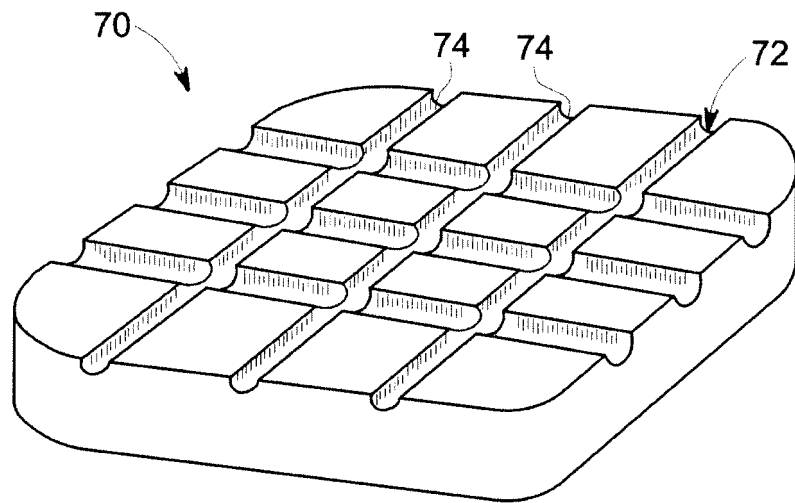

FIG. 5

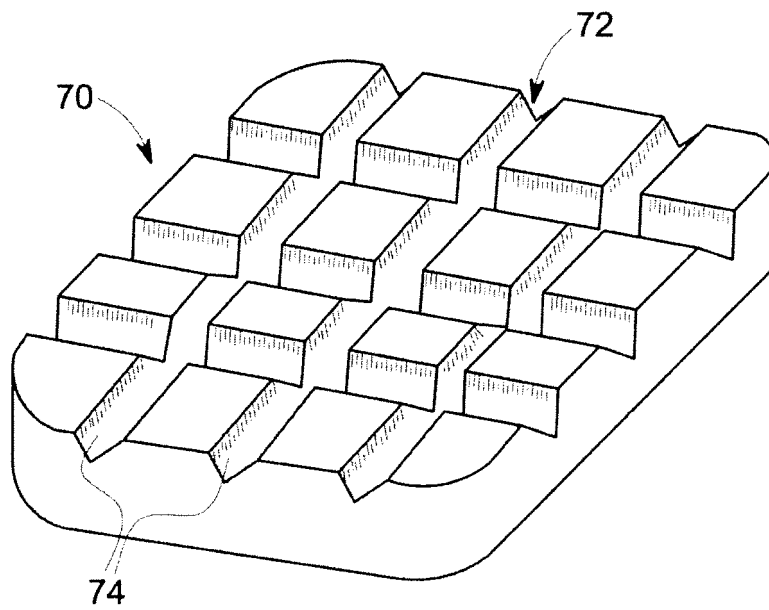

FIG. 6

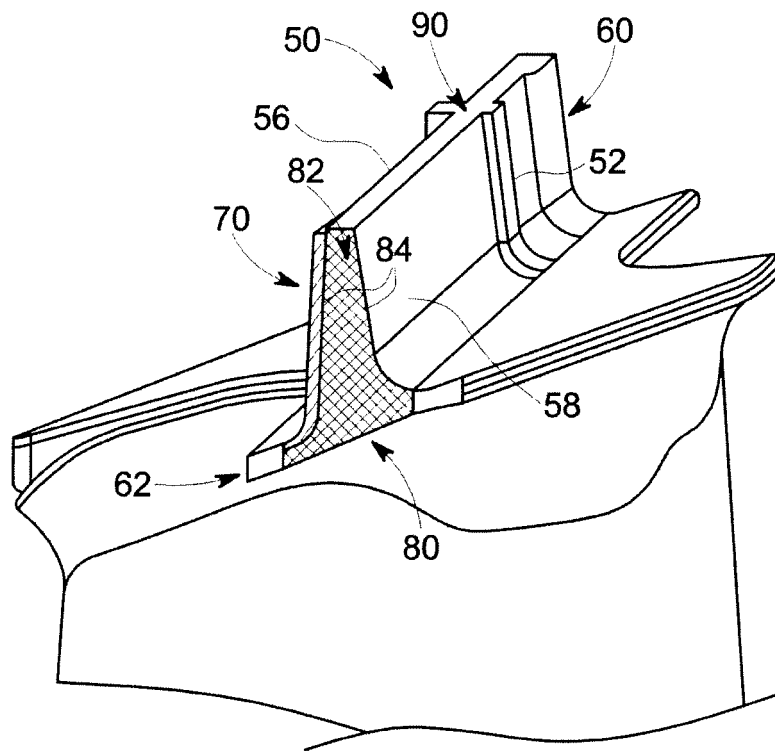

FIG. 7

**REFERENCES CITED IN THE DESCRIPTION**

*This list of references cited by the applicant is for the reader's convenience only. It does not form part of the European patent document. Even though great care has been taken in compiling the references, errors or omissions cannot be excluded and the EPO disclaims all liability in this regard.*

**Patent documents cited in the description**

- US 6164916 A [0004]
- WO 2011009430 A1 [0004]