



(11) **EP 2 628 891 A1**

(12) **EUROPEAN PATENT APPLICATION**
published in accordance with Art. 153(4) EPC

(43) Date of publication:
21.08.2013 Bulletin 2013/34

(51) Int Cl.:
E21B 17/00 (2006.01) E21B 17/04 (2006.01)
E21B 17/042 (2006.01) E21B 17/046 (2006.01)

(21) Application number: **10858290.9**

(86) International application number:
PCT/CN2010/077672

(22) Date of filing: **12.10.2010**

(87) International publication number:
WO 2012/048458 (19.04.2012 Gazette 2012/16)

(84) Designated Contracting States:
AL AT BE BG CH CY CZ DE DK EE ES FI FR GB GR HR HU IE IS IT LI LT LU LV MC MK MT NL NO PL PT RO RS SE SI SK SM TR

(72) Inventor: **FENG, Chunbao**
Shijiazhuang
Hebei 050035 (CN)

(71) Applicant: **Shijiazhuang Zhongmei Coal Mine Equipment Manufacture Co., Ltd.**
Hebei 050035 (CN)

(74) Representative: **Becker, Philippe et al**
Cabinet Becker & Associés
25, rue Louis Le Grand
F-75002 Paris (FR)

(54) **ASSEMBLED DRILLING TOOL**

(57) An assembled drilling tool has a drilling bit (2) connected with a drilling stem (1) through a drilling bit joint (3). The drilling stem is connected by drilling stem sections (11). Each drilling stem section includes an inner stem section (111) and a hollow outer stem section (112). The inner stem section is rotatably fixed in the outer stem section. The inner stem sections are connected together to form inner stem (11') of the drilling stem, and the outer stem sections are connected together to form outer stem (12') of the drilling stem. The inner stem is connected with an output shaft of a power machine, and the outer stem is fixedly connected with the shell of the power machine. The length of the drilling stem of the assembled drilling tool can be arbitrarily adjusted, and the drilling bit can be rotated with high speed without friction generated between the drilling stem and the hole wall, thereby improving the speed and the efficiency of hole drilling.

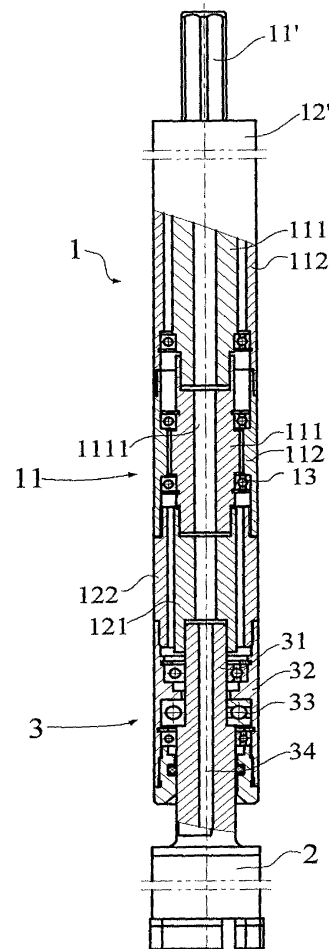

Fig.1

EP 2 628 891 A1

Description

Field of the Invention

[0001] The present invention relates to a drilling tool, especially to an assembled drilling tool, and more specifically, to an assembled drilling tool suitable for quick drilling in hard rocks.

Background of the Invention

[0002] Drilling in rocks is a very important work in industries such as mining, building, tunneling and etc., for example, drilling anchor holes and blast holes. During drilling, drilling tools will be used, and different drilling tools will be used according to different drilling principles. Currently there is mainly an impact rotary drilling and a rotary drilling, and the impact rotary drilling refers to impacting and squeezing rocks, soil and etc. with a drilling bit to crush them, thereby achieving drilling; and the rotary drilling refers to cutting and grinding rocks, soil and etc. with a drilling bit so as to achieving drilling. During drilling, regardless of which working principle, a common feature is to deliver the power of a power machine to a drilling bit with a drilling stem so as to finish drilling work. Therefore, the drilling stems connected with the drilling bit differ correspondingly, such as an impact rotary drilling stem, a rotary drilling stem and etc., and there are many types of sections of the drilling stems, such as a round drilling stem, a hexagonal drilling stem, a spiral drilling stem and etc. Currently there are two manners of drilling stems that are usually used, i.e., one is to use the impact rotary drilling stem for drilling in combination with a corresponding drilling bit, in which the impact force and cutting force of a power machine are delivered to the drilling bit, and the drilling object is achieved by frequently impacting rocks, soil and etc. with the drilling bit and then crushing them; and the other is to use the rotary drilling stem for drilling in combination with a corresponding drilling bit, in which only the cutting force and grinding force of a power machine are delivered to the drilling bit, and the drilling object is achieved by only cutting and grinding rocks, soil and etc.

[0003] The above two manners both have fatal defects, and for the first manner, as there is much mechanical vibration during drilling, which has a high power demand, and there is friction between the drilling stem and a hole wall, there is large power consumption, loud noise and slow drilling speed, and deep holes could hardly be drilled. For the second manner, although drilling can be achieved through highspeed rotary cutting, thereby improving drilling speed and drilling deep holes, increased rotating speed must worsen the friction between the drilling stem and the hole wall, which increases the power consumption and quickens the wearing of the drilling stem, and the stability and safety of the drilling stem will be lowered greatly.

[0004] A common feature of the above prior art is to

deliver the power of the drilling machine to the drilling bit through the rotation and/or axial movement of the drilling stem, and then a common defect is that the drilling stem will inevitably have friction with the hole wall during movement, when the drilled hole is too deep, much power will be consumed by the friction between the drilling stem and the hole wall, and to drill holes, only the power can be increased, which will further render resource waste; in addition, as there is friction between the drilling stem and the hole wall during drilling, the service life of the drilling stem will be shortened due to wearing, which increases the drilling cost. In addition, in the above prior art the length of the drilling stem is constant, if different depths of holes are to be drilled, this can only be achieved by changing drilling stems, thus multiple drilling stems of different specifications should be made, which renders high processing cost and inconvenient construction.

[0005] Therefore, it is especially important and urgent to develop a drilling tool which can reduce the friction between the drilling stem and the hole wall, and can also deliver enough rotating speed to the drilling bit without consuming excessive power, and also, the specifications of the drilling stem need to be reduced to meet the needs of drilling different depths of holes.

Summary of the Invention

Technical problem

[0006] To solve the above problems in the prior art of large friction between the drilling stem and the hole wall, low efficiency, high cost and inconvenient construction due to too many specifications of the drilling stem and etc., or to solve at least one of such problems, the present invention provides an assembled drilling tool which effectively solves the above defects of the prior art.

Technical solution

[0007] The assembled drilling tool comprises a drilling stem 1, a drilling bit 2 and a drilling bit joint 3, the drilling bit 2 is connected with the drilling stem 1 through the drilling bit joint 3, characterized in that, the drilling stem 1 is formed by connecting drilling stem sections 11 each of which includes an inner stem section 111 and a hollow outer stem section 112, and the inner stem section 111 is rotatably fixed in the outer stem section 112, the inner stem sections 111 of each of the drilling stem sections 11 are connected together to form inner stem 11' of the drilling stem 1, the outer stem sections 112 are connected together to form outer stem 12' of the drilling stem 1, and the inner stem 11' of the drilling stem 1 is connected with the output shaft of a power machine, and the outer stem 12' is fixedly connected with the shell of the power machine.

[0008] Preferably, the drilling bit joint 3 comprises an inner joint 31 and a hollow outer joint 32, the inner joint 31 is rotatably mounted within the outer joint 32, the inner

joint 31 is connected with the inner stem 11' of the drilling stem 1 at one end and with the drilling bit 2 at the other end, and the axial force and the radial force of the drilling bit 2 are delivered to the outer joint 32 through the inner joint 31, and the outer joint 32 is connected with the outer stem 12' of the drilling stem 1 at one end.

[0009] Furthermore, the inner stem sections 111 of the drilling stem sections 11 are mounted within the outer stem sections 112 through a bearing 13, and the inner stem sections 111 are coaxial with the outer stem sections 112 and formed with a center hole 1111.

[0010] The inner joint 31 of the drilling bit joint 3 is mounted within the outer joint 32 through a bearing 33, and the inner joint 31 is coaxial with the outer joint 32 and formed therein with a through hole 34 which is in communication with the center hole 1111.

[0011] The bearing 13 of the drilling stem section 11 comprises two bearings 131, 132 keeping concentric, and the bearing 33 of the drilling bit joint 3 comprises one axial bearing 331 bearing an axial force and two radial bearings 332, 333 bearing a radial force and keeping concentric.

[0012] Preferably, the two bearings 131, 132 keeping concentric are self-aligning ball bearings respectively provided at two ends of the inner stem sections 111, the axial bearing 331 is a thrust ball bearing, and the radial bearings 332, 333 are self-aligning ball bearings at two sides of the axial bearing 331.

[0013] Furthermore, the inner stem sections 111 of the adjacent drilling stem sections 11 of the drilling stem 1 are connected together through a thread or tongue-and-groove structure, and the outer stem sections 112 are connected together through a thread or tongue-and-groove structure.

[0014] The inner stem 11' of the drilling stem 1 is connected with the inner joint 31 of the drilling bit joint 3 through a thread or tongue-and-groove structure, and the outer stem 12' is connected with the outer joint 32 through a thread or tongue-and-groove structure.

[0015] Preferably, the inner stem section 111 of the drilling stem section 11 of the drilling stem 1 is a square groove 1112 at one end and is a square head 1113 at the other end, and the square head 1113 can be inserted into the square groove 1112, the outer stem section 112 of the drilling stem section 11 is an inner thread 1121 at one end and is an outer thread 1122 at the other end, and the outer thread 1122 can be screwed into the inner thread 1121.

[0016] The inner joint 31 of the drilling bit joint 3 is a square groove 312 at one end, the square head 1113 at one end of the inner stem 11' of the drilling stem 1 can be inserted into the square groove 312 at one end of the inner joint 31, the outer joint 32 is an inner thread 321 at one end, and the outer thread 1122 at one end of the outer stem 12' of the drilling stem 1 can be screwed into the inner thread 321 at one end of the outer joint 32.

[0017] Furthermore, the outer joint 32 of the drilling bit joint 3 is further provided with a plug 322 at the other end,

the plug 322 is fixed at the outer joint 32 through a thread, a sealing ring 35 is provided between the plug 322 and the inner joint 31, the inner joint 31 is provided with a step 311 at the outer surface, and the step 311 abuts against the axial bearing 331.

[0018] Furthermore, the inner stem sections 111 of adjacent drilling stem sections 11 of the drilling stem 1 are connected together through an inner stem joint 121, and the outer stem sections 112 are connected together through an outer stem joint 122.

[0019] The inner stem sections 111 of the drilling stem 1 are connected with the inner joint 31 of the drilling bit joint 3 through the inner stem joint 121, and the outer stem sections 112 are connected with the outer joint 32 through the outer stem joint 122.

[0020] Preferably, the inner stem sections 111 and the inner joint 31 are connected with the inner stem joint 121 through a thread or tongue-and-groove structure, and the outer stem sections 112 and the outer joint 32 are connected with the outer stem joint 122 through a thread or tongue-and-groove structure.

Advantageous effects

[0021] According to the above assembled drilling tool provided by the present invention, the drilling stem is formed by connecting multiple drilling stem sections, the length of the drilling stem can be adjusted arbitrarily so as to adapt to needs of drilling different depths of holes, which reduces the specifications and models of the drilling stem and makes the drilling construction convenient; for the drilling stem sections connected with each other, the inner stem sections are connected together to form the inner stem of the drilling stem, the outer stem sections are connected together to form the outer stem of the drilling stem, the inner stem connects the output shaft of the power machine with the drilling bit, and the axial force and the radial force of the drilling bit are delivered to the outer stem through the drilling bit joint, so that the inner stem connected with the drilling bit can rotate at a high speed in the outer stem without having friction with the hole wall and delivers the torque of the power machine to the drilling bit through the inner stem, while the outer stem is fixedly connected with the shell of the power machine and then keeps fixed and only bears the axial force and the radial force of the drilling bit, thus the combination of the inner stem and the outer stem of the present invention can rotate the drilling bit at a high speed without the friction between the drilling stem and the hole wall, thereby greatly improving the drilling speed and efficiency; in addition, as the inner stem sections are formed with a center hole in the center, and then center holes in communication with each other are formed in the center of the inner stem, and this can pass through water and discharge slag and further optimize the drilling work, and quick drilling can be achieved even in hard rocks.

Brief Description of the Accompanying Drawings

[0022]

Fig. 1 is a schematic diagram of an embodiment of the assembled drilling tool of the present invention; Fig. 2 is a schematic diagram of a single drilling stem section in the embodiment shown in Fig. 1; Fig. 3 is a schematic diagram of the drilling bit joint in the embodiment shown in Fig. 1; Fig. 4 is a schematic diagram of a connection manner of two drilling stem sections shown in Fig. 2; Fig. 5 is a schematic diagram of a connection manner of the drilling stem section shown in Fig. 2 and the drilling bit joint shown in Fig. 3; Fig. 6 is a schematic diagram of another connection manner of two drilling stem sections shown in Fig. 2; and Fig. 7 is a schematic diagram of another connection manner of the drilling stem section shown in Fig. 2 and the drilling bit joint shown in Fig. 3.

Detailed Description of the Invention

[0023] To more clearly understand the above objects, features and advantages of the present invention, the present invention will be further detailed hereinafter taken in conjunction with the accompanying drawings and specific embodiments.

[0024] Many details are described hereinafter for fully understanding of the present invention, however, the present invention can be implemented with other manners different from the following description, and thus, the present invention is not restricted by the following embodiments.

[0025] Figs. 1-5 show a structure of the assembled drilling tool according to the present invention and the constitution thereof, and the structure and the connection relationship of the respective constitution parts. Wherein, Fig. 1 shows a structure and the constitution of an embodiment of the assembled drilling tool of the present invention, Fig. 2 shows the structure of a single drilling stem section in the assembled drilling tool, Fig. 3 shows the structure of the drilling bit joint in this assembled drilling tool, Fig. 4 shows a connecting structure of adjacent drilling stem sections in the assembled drilling tool, and Fig. 5 shows a connecting structure of the drilling stem sections and the drilling bit joint in this assembled drilling tool.

[0026] As shown in Fig. 1, the assembled drilling tool comprises a drilling stem 1, a drilling bit 2 and a drilling bit joint 3, the drilling bit 2 is connected with the drilling stem 1 through the drilling bit joint 3, characterized in that, the drilling stem 1 is formed by connecting drilling stem sections 11 each of which includes an inner stem section 111 and a hollow outer stem section 112, and the inner stem section 111 is rotatably fixed in the outer stem section 112, the inner stem sections 111 of each

of the drilling stem sections 11 are connected together to form inner stem 11' of the drilling stem 1, the outer stem sections 112 are connected together to form outer stem 12' of the drilling stem 1, and the inner stem 11' of the drilling stem 1 is connected with the output shaft of a power machine, and the outer stem 12' of the drilling stem 1 is fixedly connected with the shell of the power machine.

[0027] The drilling bit joint 3 comprises an inner joint 31 and a hollow outer joint 32, the inner joint 31 is rotatably mounted within the outer joint 32, the inner joint 31 is connected with the inner stem 11' of the drilling stem 1 at one end and with the drilling bit 2 at the other end, and the axial force and the radial force of the drilling bit 2 are delivered to the outer joint 32 through the inner joint 31, and the outer joint 32 is connected with the outer stem 12' of the drilling stem 1 at one end.

[0028] For the above assembled drilling tool provided by the present invention, the drilling stem therein can be formed by arbitrary combination of the drilling stem sections, thus the length of the drilling stem can be adjusted arbitrarily so as to meet needs of drilling different depths of holes; the drilling stem sections forming the drilling stem comprise outer stem sections and inner stem sections, and the inner stem sections of each of the drilling stem sections are connected together to form the inner stem of the drilling stem and the outer stem sections are connected together to form the outer stem of the drilling stem, and finally, the outer stem is fixedly connected with the shell of the power machine and the inner stem is connected with the output shaft of the power machine. Thus, during drilling, the outer stem does not move, and the inner stem rotates freely within the outer stem and delivers power to the drilling bit for drilling, in this process, as the outer stem does not move, the drilling stem does not have friction with the hole wall, which reduces power loss and prolong the service life of the drilling stem; in addition, the drilling bit joint in the assembled drilling tool of the present invention can deliver the axial force and the radial force generated by the drilling bit to the outer stem and then to the shell of the power machine through the outer stem, so that the inner stem sections do not bear any axial force or radial force, this not only prolongs the service life of the inner stem but also achieves the high speed rotation of the inner stem and increases the drilling speed, that is, the drilling efficiency is improved.

[0029] Preferably, as shown in Fig. 2, in this embodiment, the inner stem sections 111 of the drilling stem sections 11 are mounted within the outer stem sections 112 through a bearing 13, and the inner stem sections 111 are coaxial with the outer stem sections 112 and formed with a center hole 1111. the bearing 13 of the drilling stem section 11 comprises two self-aligning ball bearings 131, 132 keeping concentric, and the bearings 131, 132 are respectively provided at two ends of the inner stem sections 111, the outer stem section 112 of the drilling stem section 11 is an inner thread 1121 at one end and is an outer thread 1122 at the other end, and

the outer thread 1122 can be screwed into the inner thread 1121. This structure can ensure the connection between the inner stem sections of each drilling stem section and the connection between the outer stem sections, and in the situation that the inner stem sections keep coaxial with the outer stem sections, the inner stem sections rotate at a high speed within the outer stem sections, while the outer stem keeps motionless. In addition, the center holes of the inner stem sections are connected to be a through hole leading to the drilling bit, so that water can be provided to the drilling bit and slag can be discharged, thereby improving the drilling efficiency and elongating the service life of the drilling bit.

[0030] Furthermore, as shown in Fig. 3, in this embodiment, the inner joint 31 of the drilling bit joint 3 is mounted within the outer joint 32 through a bearing 33, and the inner joint 31 is coaxial with the outer joint 32 and formed therein with a through hole 34 which is in communication with the center hole 1111, and the bearing 33 of the drilling bit joint 3 comprises one thrust ball bearing 331 bearing an axial force and two self-aligning ball bearings 332, 333 which bear a radial force and keep concentric, and the self-aligning ball bearings 332, 333 are located at two sides of the thrust ball bearing 331, and the inner joint 31 is provided at the outer surface with a step 311 which abuts against the bearing 331. Such a structure of the drilling bit joint can not only keep the inner joint and the outer joint coaxial so as to rotate the inner joint at a high speed, but also deliver the axial force and the radial force of the drilling bit to the outer joint through the inner joint and then to the outer stem. In addition, the through hole of the inner joint is in communication with the center hole of the inner stem, and then water can be supplied and slag can be discharged.

[0031] Preferably, as shown in Fig. 4, the inner stem sections 111 of the adjacent drilling stem sections 11 of the drilling stem 1 are connected together through, and the outer stem sections 112 are connected together through, a thread or tongue-and-groove structure, and in this embodiment, the inner stem section 111 of the drilling stem section 11 of the drilling stem 1 is a square groove 1112 at one end and is a square head 1113 at the other end, and the square head 1113 can be inserted into the square groove 1112, the outer stem section 112 of the drilling stem section 11 is an inner thread 1121 at one end and is an outer thread 1122 at the other end, and the outer thread 1122 can be screwed into the inner thread 1121 to achieve the connection between the inner stem sections and the connection between the outer stem sections. In this embodiment, a connection manner of the square head and the square groove is used for the inner stem sections, and after the connection, the inner stem constituted by the inner stem sections is a square head at one end and is a square groove at the other end, which can be respectively connected with the inner joint of the drilling bit joint and the output shaft of the power machine; a connection manner of inner and outer threads is used for the outer stem sections, and after the connec-

tion, the outer stem constituted by the outer stem sections is an outer thread at one end and is an inner thread at the other end, which can be respectively connected with the outer joint of the drilling bit joint and the shell of the power machine.

[0032] In the above embodiment, although the inner stem sections are described with the connection manner of inner and outer quadrilateral threads and groove, one skilled in the art would know that multiple connection manners can be used, such as inner and outer thread connection, inner and outer and hexagonal connection, inner and outer triangle - sided connection and etc.; the outer stem sections are described with the connection manner of inner and outer threads, while multiple connection manners can be used, such as inner and outer triangle connection, inner and outer quadrilateral connection, inner and outer and hexagonal connection and etc.

[0033] Furthermore, as shown in Fig. 5, the inner stem 11' of the drilling stem 1 is connected with the inner joint 31 of the drilling bit joint 3 through, and the outer stem 12' is connected with the outer joint 32 through, a thread or tongue-and-groove structure. In this embodiment, the inner joint 31 of the drilling bit joint 3 is a square groove 312 at one end, the square head 1113 of the inner stem sections 111 at one end of the inner stem 11' of the drilling stem 1 can be inserted into the square groove 312 at one end of the inner joint 31; the outer joint 32 is an inner thread 321 at one end, the outer thread 1122 of the outer stem section 112 at one end of the outer stem 12' of the drilling stem 1 can be screwed into the inner thread 321 at one end of the outer joint 32, thus achieving the connection between the inner stem and the inner stem joint and the connection between the outer stem and the outer stem joint.

[0034] Likewise, in the above embodiment, although the connection between the inner stem and the inner joint is described with the connection manner of inner and outer quadrilateral threads and groove, one skilled in the art would know that multiple connection manners can be used, such as inner and outer thread connection, inner and outer and hexagonal connection, inner and outer triangle - sided connection and etc.; the connection between the outer stem and the outer joint is described with the connection manner of inner and outer threads, while multiple connection manners can be used, such as inner and outer triangle - sided connection, inner and outer quadrilateral connection, inner and outer and hexagonal connection and etc.

[0035] In the above embodiment, as shown in Fig. 3, the outer joint 32 of the drilling bit joint 3 is further provided with a plug 322 at the other end, the plug 322 is fixed at the outer joint 32 through a thread, and a sealing ring 35 is provided between the plug 322 and the inner joint 31. This structure intends to make the mounting of the thrust ball bearing 331 convenient and keeps fine lubrication between the radial bearing and the thrust bearing, and prolongs the service life.

[0036] Figs. 6 and 7 respectively show another connection manner of the drilling stem sections and another connection manner of the drilling stem sections and the drilling bit joint.

[0037] As shown in Fig. 6, the inner stem sections 111 of adjacent drilling stem sections 11 of the drilling stem 1 are connected together through an inner stem joint 121, and the outer stem sections 112 are connected together through an outer stem joint 122. In this embodiment, the inner stem sections 111 are connected with the inner stem joint 121 through a tongue-and-groove structure, and the outer stem sections 112 are connected with the outer stem joint 122 through a thread.

[0038] As shown in Fig. 7, the inner stem sections 111 of the drilling stem 1 are connected with the inner joint 31 of the drilling bit joint 3 through the inner stem joint 121, and the outer stem sections 112 are connected with the outer joint 32 through the outer stem joint 122. In this embodiment, the inner joint 31 is connected with the inner stem joint 121 through a tongue-and-groove structure, and the outer joint 32 is connected with the outer stem joint 122 through a thread structure.

[0039] In the embodiments shown in Figs. 6 and 7, although the connection between the inner stem sections and the inner joint and the inner stem joint is illustrated with the connection manner of inner and outer quadrilateral threads and groove, one skilled in the art would know that multiple connection manners can be used, such as inner and outer thread connection, inner and outer and hexagonal connection, inner and outer triangle - sided connection and etc.; the connection between the outer stem sections and the outer joint and the outer stem joint is illustrated with the connection manner of inner and outer threads, while multiple connection manners can be used, such as inner and outer triangle - sided connection, inner and outer quadrilateral connection, inner and outer and hexagonal connection and etc.

[0040] The above are merely preferred embodiments of the present invention and are not intended to limit the present invention. For one skilled in the art, the present invention may have various alterations and changes. Any alterations, equivalent substitutions, improvements and etc. within the spirit and principle of the present invention, should be covered in the scope of protection of the present invention.

Claims

1. An assembled drilling tool comprising a drilling stem (1), a drilling bit (2) and a drilling bit joint (3), the drilling bit (2) being connected with the drilling stem (1) through the drilling bit joint (3), **characterized in that**, the drilling stem (1) is formed by connecting drilling stem sections (11) each of which includes an inner stem section (111) and a hollow outer stem section (112), and the inner stem section (111) is rotatably fixed in the outer stem section (112), the

inner stem sections (111) of each of the drilling stem sections (11) are connected together to form inner stem (11') of the drilling stem (1), the outer stem sections (112) are connected together to form outer stem (12') of the drilling stem (1), and the inner stem (11') of the drilling stem (1) is connected with the output shaft of a power machine, and the outer stem (12') is fixedly connected with the shell of the power machine.

2. The assembled drilling tool according to Claim 1, **characterized in that**, the drilling bit joint (3) comprises an inner joint (31) and a hollow outer joint (32), the inner joint (31) is rotatably mounted within the outer joint (32), the inner joint (31) is connected with the inner stem (11') of the drilling stem (1) at one end and with the drilling bit (2) at the other end, and the axial force and the radial force of the drilling bit (2) are delivered to the outer joint (32) through the inner joint (31), and the outer joint (32) is connected with the outer stem (12') of the drilling stem (1).
3. The assembled drilling tool according to Claim 2, **characterized in that**, the inner stem sections (111) of the drilling stem sections (11) are mounted within the outer stem sections (112) through a bearing (13), and the inner stem sections (111) are coaxial with the outer stem sections (112) and formed with a center hole (1111).
4. The assembled drilling tool according to Claim 3, **characterized in that**, the inner joint (31) of the drilling bit joint (3) is mounted within the outer joint (32) through a bearing (33), and the inner joint (31) is coaxial with the outer joint (32) and formed therein with a through hole (34) which is in communication with the center hole (1111).
5. The assembled drilling tool according to Claim 4, **characterized in that**, the bearing (13) of the drilling stem section (11) comprises two bearings (131, 132) keeping concentric, and the bearing (33) of the drilling bit joint (3) comprises one axial bearing (331) bearing an axial force and two radial bearings (332, 333) bearing a radial force and keeping concentric.
6. The assembled drilling tool according to Claim 5, **characterized in that**, the two bearings (131, 132) keeping concentric are self-aligning ball bearings respectively provided at two ends of the inner stem sections (111), the axial bearing (331) is a thrust ball bearing, and the two radial bearings (332, 333) are self-aligning ball bearings at two sides of the axial bearing (331).
7. The assembled drilling tool according to any of Claims 1 to 6, **characterized in that**, the inner stem sections (111) of the adjacent drilling stem sections

(11) of the drilling stem (1) are connected together through a thread or tongue-and-groove structure, and the outer stem sections (112) are connected together through a thread or tongue-and-groove structure.

8. The assembled drilling tool according to Claim 7, **characterized in that**, the inner stem (11') of the drilling stem (1) is connected with the inner joint (31) of the drilling bit joint (3) through a thread or tongue-and-groove structure, and the outer stem (12') is connected with the outer joint (32) through a thread or tongue-and-groove structure.
9. The assembled drilling tool according to Claim 8, **characterized in that**, the inner stem section (111) of the drilling stem section (11) of the drilling stem (1) is a square groove (1112) at one end and is a square head (1113) at the other end, and the square head (1113) can be inserted into the square groove (1112), the outer stem section (112) of the drilling stem section (11) is an inner thread (1121) at one end and is an outer thread (1122) at the other end, and the outer thread (1122) can be screwed into the inner thread (1121).
10. The assembled drilling tool according to Claim 9, **characterized in that**, the inner joint (31) of the drilling bit joint (3) is a square groove (312) at one end, the square head (1113) at one end of the inner stem (11') of the drilling stem (1) can be inserted into the square groove (312) at one end of the inner joint (31), the outer joint (32) is an inner thread (321) at one end, and the outer thread (1122) at one end of the outer stem (12') of the drilling stem (1) can be screwed into the inner thread (321) at one end of the outer joint (32).
11. The assembled drilling tool according to Claim 10, **characterized in that**, the outer joint (32) of the drilling bit joint (3) is further provided with a plug (322) at the other end, the plug (322) is fixed at the outer joint (32) through a thread, a sealing ring (35) is provided between the plug (322) and the inner joint (31), the inner joint (31) is provided with a step (311) at the outer surface, and the step (311) abuts against the axial bearing (331).
12. The assembled drilling tool according to any of Claims 1 to 6, **characterized in that**, the inner stem sections (111) of adjacent drilling stem sections (11) of the drilling stem (1) are connected together through an inner stem joint (121), and the outer stem sections (112) are connected together through an outer stem joint (122).
13. The assembled drilling tool according to Claim 12, **characterized in that**, the inner stem (11') of the

drilling stem (1) is connected with the inner joint (31) of the drilling bit joint (3) through the inner stem joint (121), and the outer stem (12') is connected with the outer joint (32) through the outer stem joint (122).

14. The assembled drilling tool according to Claim 13, **characterized in that**, the inner stem sections (111) and the inner joint (31) are connected with the inner stem joint (121) through a thread or tongue-and-groove structure, and the outer stem sections (112) and the outer joint (32) are connected with the outer stem joint (122) through a thread or tongue-and-groove structure.

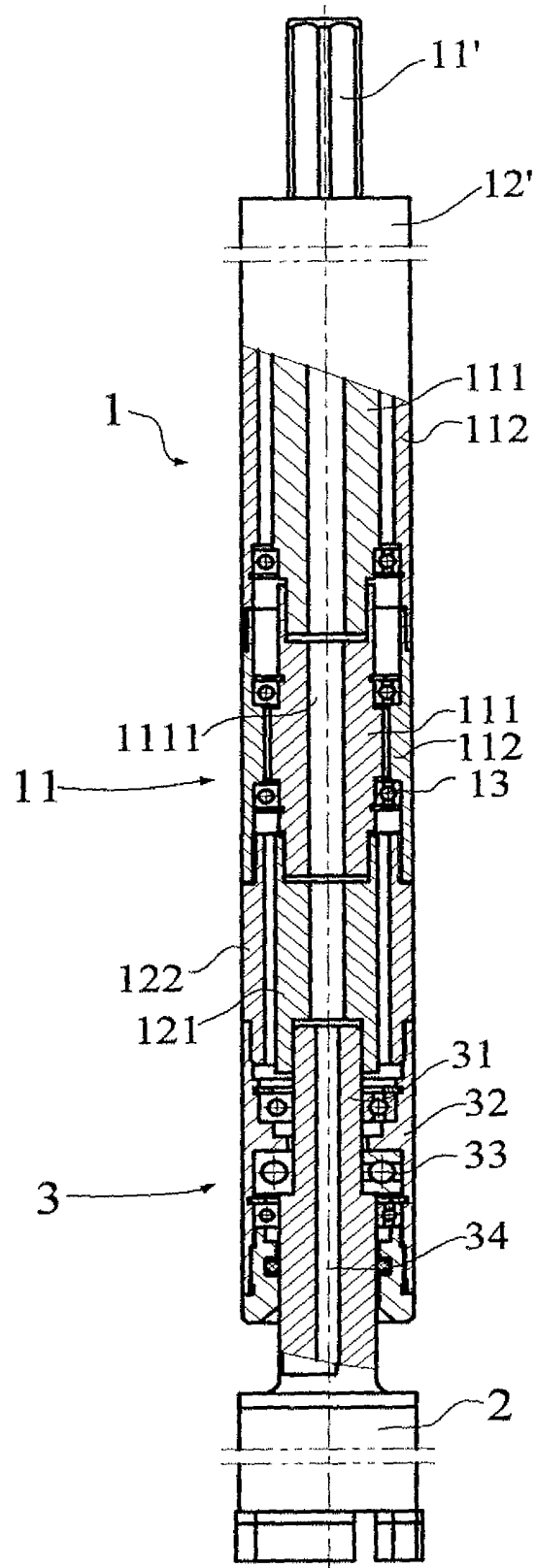

Fig.1

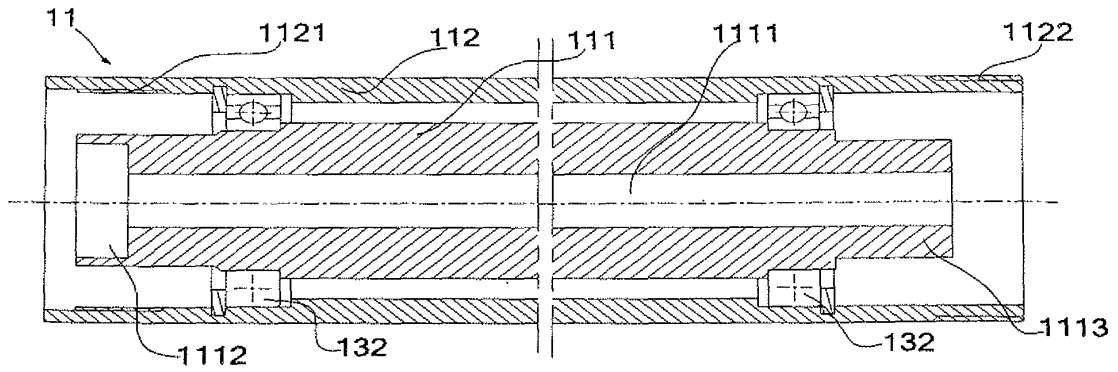

Fig.2

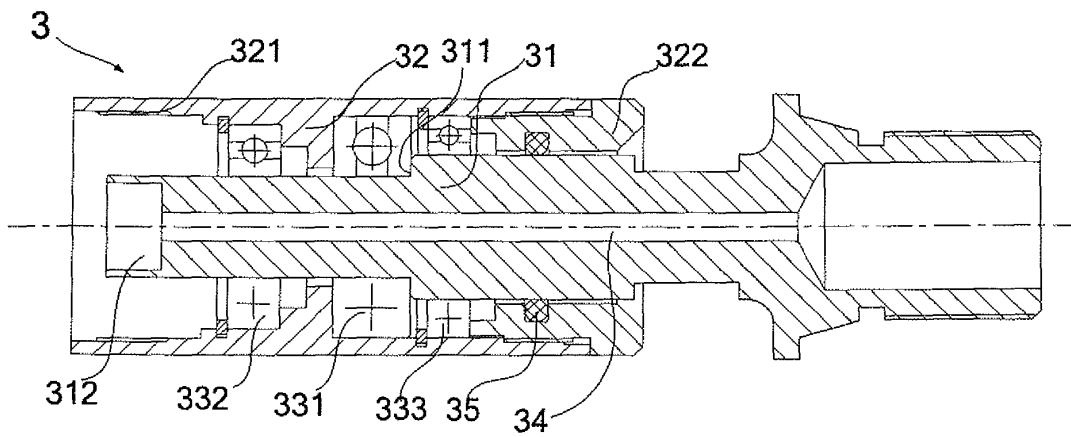

Fig.3

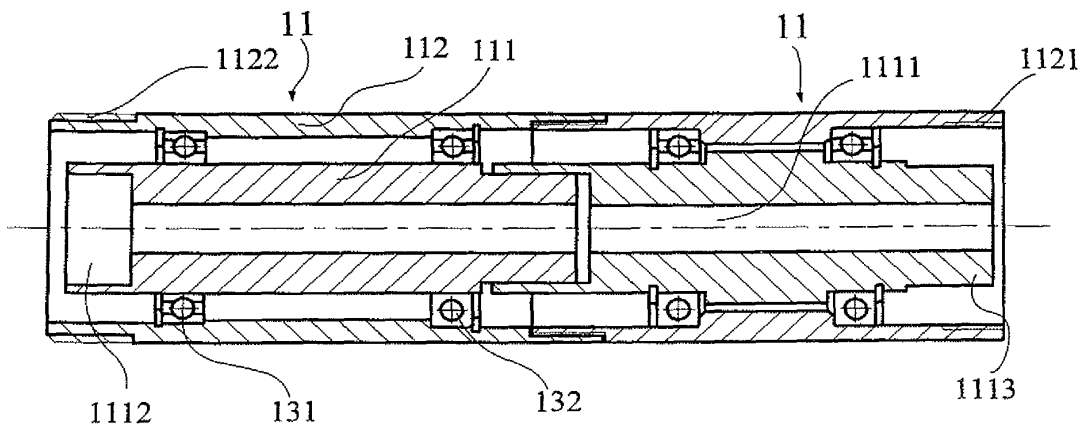

Fig.4

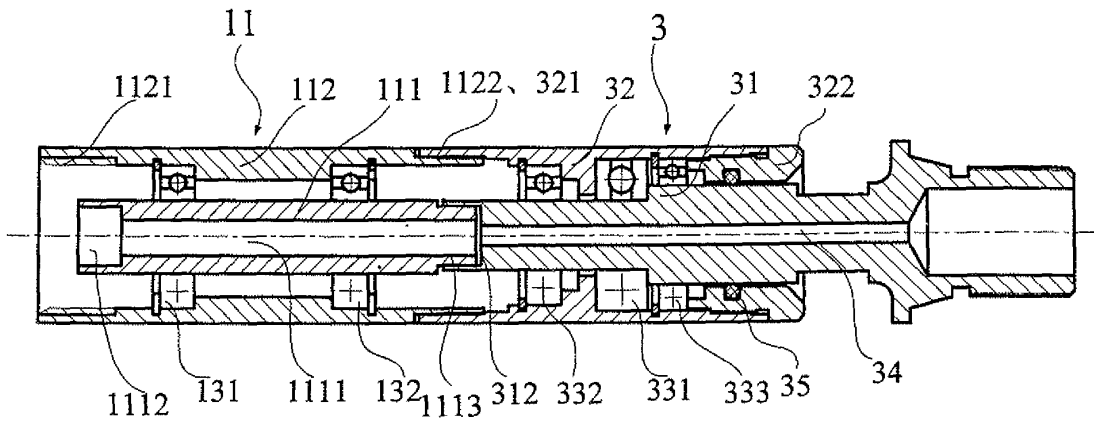

Fig.5

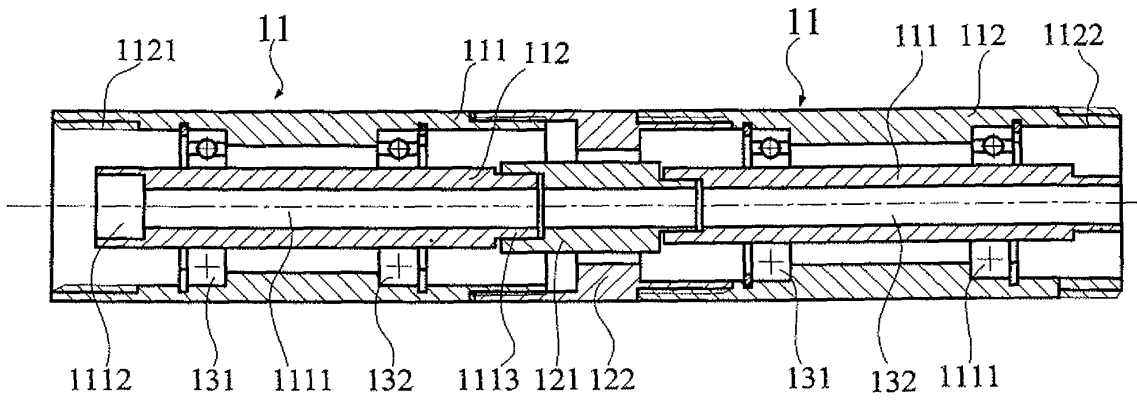

Fig.6

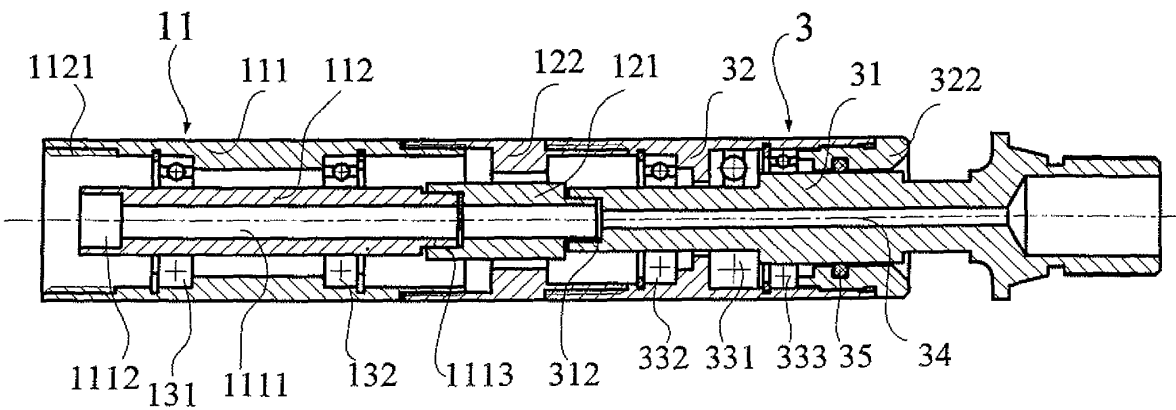

Fig.7

INTERNATIONAL SEARCH REPORT

International application No.

PCT/CN2010/077672

A. CLASSIFICATION OF SUBJECT MATTER

See the extra sheet

According to International Patent Classification (IPC) or to both national classification and IPC

B. FIELDS SEARCHED

Minimum documentation searched (classification system followed by classification symbols)

IPC: E21B

Documentation searched other than minimum documentation to the extent that such documents are included in the fields searched

Electronic data base consulted during the international search (name of data base and, where practicable, search terms used)

CPRSABS, CNABS, SIPOABS, DWPI, VEN: combine, drilling bit, drilling stem, inner stem, outer stem, bearing, serial, cascade, connect

C. DOCUMENTS CONSIDERED TO BE RELEVANT

Category*	Citation of document, with indication, where appropriate, of the relevant passages	Relevant to claim No.
Y	CN2761810Y (LIAOHE PETROLEUM EXPLORATION) 01 Mar. 2006 (01.03.2006) page 3 of the description, figure 1	1, 7-10, 12-14
Y	CN101240692A (EURODRILL GMBH) 13 Aug. 2008 (13.08.2008) abstract, figure 1	1, 7-10, 12-14
A	CN2619041Y (ZHANG, Shuming) 02 Jun. 2004 (02.06.2004) the whole document	1-14
A	CN101220731A (UNIV CHINA PETROLEUM BEIJING) 16 Jul. 2008 (16.07.2008) the whole document	1-14
A	DE3503893C1 (ING KLEMM G SPEZI B) 24 Oct. 1985 (24.10.1985) the whole document	1-14
A	IE68767B2 (MINROC TECH PROMOTIONS LTD) 10 Jul. 1996 (10.07.1996) the whole document	1-14

 Further documents are listed in the continuation of Box C.
 See patent family annex.

* Special categories of cited documents:	"T" later document published after the international filing date or priority date and not in conflict with the application but cited to understand the principle or theory underlying the invention
"A" document defining the general state of the art which is not considered to be of particular relevance	"X" document of particular relevance; the claimed invention cannot be considered novel or cannot be considered to involve an inventive step when the document is taken alone
"E" earlier application or patent but published on or after the international filing date	"Y" document of particular relevance; the claimed invention cannot be considered to involve an inventive step when the document is combined with one or more other such documents, such combination being obvious to a person skilled in the art
"L" document which may throw doubts on priority claim (S) or which is cited to establish the publication date of another citation or other special reason (as specified)	"&" document member of the same patent family
"O" document referring to an oral disclosure, use, exhibition or other means	
"P" document published prior to the international filing date but later than the priority date claimed	

Date of the actual completion of the international search 17 Jun. 2011 (17.06.2011)	Date of mailing of the international search report 07 Jul. 2011 (07.07.2011)
Name and mailing address of the ISA/CN The State Intellectual Property Office, the P.R.China 6 Xitucheng Rd., Jimen Bridge, Haidian District, Beijing, China 100088 Facsimile No. 86-10-62019451	Authorized officer LV,Dejun Telephone No. (86-10)62085260

INTERNATIONAL SEARCH REPORT
Information on patent family members

International application No.
PCT/CN2010/077672

Patent Documents referred in the Report	Publication Date	Patent Family	Publication Date
CN2761810Y	01. 03. 2006	NONE	
CN101240692A	13. 08. 2008	DE202007001858U	05.04.2007
CN2619041Y	02.06.2004	NONE	
CN101220731A	16.07.2008	NONE	
DE3503893C1	24.10.1985	EP0190669A2	13.08.1986
		EP0190669B1	23.11.1989
		AT48176T	15.12.1989
IE68767B2	10.07.1996	IE950009A	10.07.1996

Form PCT/ISA /210 (patent family annex) (July 2009)

INTERNATIONAL SEARCH REPORT

International application No.

PCT/CN2010/077672

Continuation of : page 2, A. **CLASSIFICATION OF SUBJECT MATTER**

E21B17/00 (2001.06) i

E21B17/04 (2001.06) i

E21B17/042 (2001.06) i

E21B17/046 (2001.06) i