



(11) **EP 2 631 035 A3**

(12) **EUROPEAN PATENT APPLICATION**

(88) Date of publication A3:
18.10.2017 Bulletin 2017/42

(51) Int Cl.:
B25B 21/00 (2006.01) **B25F 5/02 (2006.01)**
B25F 5/00 (2006.01) **B25B 23/14 (2006.01)**

(43) Date of publication A2:
28.08.2013 Bulletin 2013/35

(21) Application number: **13156614.3**

(22) Date of filing: **25.02.2013**

(84) Designated Contracting States:
AL AT BE BG CH CY CZ DE DK EE ES FI FR GB GR HR HU IE IS IT LI LT LU LV MC MK MT NL NO PL PT RO RS SE SI SK SM TR
Designated Extension States:
BA ME

- **Seman, Andrew E.**
Pylesville, MD Maryland 21132 (US)
- **Puzio, Daniel**
Baltimore, MD Maryland 21234 (US)
- **Brotto, Daniele C.**
Baltimore, MD Maryland 21234 (US)
- **Kelleher, Joseph P.**
Parkville, MD Maryland 21234 (US)
- **Concari, Gabriel E**
Eldersburg, MD Maryland 21784 (US)
- **Murray, Christopher**
Philadelphia, Pennsylvania 191213 (US)
- **Schoch, Robert B.**
Baltimore, MD Maryland 21230 (US)

(30) Priority: **24.02.2012 US 201213404620**

(71) Applicant: **Black & Decker Inc.**
Newark, Delaware 19711 (US)

(74) Representative: **SBD IPAdmin**
210 Bath Road
Slough, Berkshire SL1 3YD (GB)

(72) Inventors:
• **Eshleman, Scott J.**
Parkville, MD Maryland 21234 (US)
• **Schell, Craig Alan**
Street, MD Maryland 21154 (US)

(54) **Power tool**

(57) A power tool comprises: a housing; an output member at least partially contained in the housing and configured to rotate about a longitudinal axis; a motor contained in the housing and drivably connected to the output member to impart rotary motion thereto; and a rotational motion sensor arranged in the housing and operable to detect rotational motion of the housing, from a first reference orientation of the housing, about the longitudinal axis of the output member. A controller is also located in the housing, the controller configured to re-

ceive a signal indicative of the rotational motion from the rotational motion sensor and, in response to the signal, to drive the motor to rotate the output member. The power tool also includes a reset switch configured to reset the rotational motion sensor to a second reference orientation of the housing, which is different to the first reference orientation, upon actuation of the reset switch, the second reference orientation then being the reference orientation from which the rotational motion sensor is operable to detect the rotational motion of the housing.

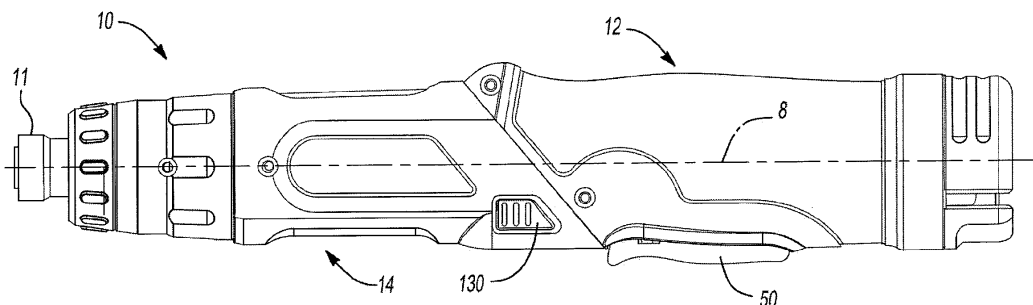

Fig-1

EP 2 631 035 A3



EUROPEAN SEARCH REPORT

Application Number
EP 13 15 6614

5

10

15

20

25

30

35

40

45

50

55

DOCUMENTS CONSIDERED TO BE RELEVANT			
Category	Citation of document with indication, where appropriate, of relevant passages	Relevant to claim	CLASSIFICATION OF THE APPLICATION (IPC)
Y	US 2011/203821 A1 (PUZIO DANIEL [US] ET AL) 25 August 2011 (2011-08-25) * paragraphs [0057] - [0064], [0037]; figures 1-7,8c,17a,17b *	1-15	INV. B25B21/00 B25F5/02 B25F5/00 B25B23/14
Y	US 4 558 601 A (STASIEK JAN S [US] ET AL) 17 December 1985 (1985-12-17) * column 2, lines 37-51; claims 17,31,32; figures 1,3 *	1-9	
Y	US 2001/048855 A1 (LIN YUAN-HO [TW]) 6 December 2001 (2001-12-06) * paragraphs [0021] - [0022]; figure 3 *	10-12	
Y	WO 2009/136840 A1 (ATLAS COPCO TOOLS AB [SE]; ELSMARK KARL JOHAN LARS [SE]; PERSSON LARS) 12 November 2009 (2009-11-12) * page 9, line 3 - page 10, line 13; claims 1,2; figures 2a,2b,3a,3b,4a,4b *	13-15	
A	EP 1 878 541 A2 (BLACK & DECKER INC [US]) 16 January 2008 (2008-01-16) * paragraphs [0013] - [0022]; figures 1,2 *	1,10,13	TECHNICAL FIELDS SEARCHED (IPC) B25B
A	US 2005/045354 A1 (ARIMURA TADASHI [JP] ET AL) 3 March 2005 (2005-03-03) * paragraphs [0041] - [0043]; figures 1,2 *	1,10,13	
The present search report has been drawn up for all claims			
Place of search The Hague		Date of completion of the search 8 September 2017	Examiner Pastramas, Nikolaos
CATEGORY OF CITED DOCUMENTS X : particularly relevant if taken alone Y : particularly relevant if combined with another document of the same category A : technological background O : non-written disclosure P : intermediate document T : theory or principle underlying the invention E : earlier patent document, but published on, or after the filing date D : document cited in the application L : document cited for other reasons & : member of the same patent family, corresponding document			

EPO FORM 1503 03.02 (P04C01)

ANNEX TO THE EUROPEAN SEARCH REPORT
ON EUROPEAN PATENT APPLICATION NO.

EP 13 15 6614

5 This annex lists the patent family members relating to the patent documents cited in the above-mentioned European search report.
The members are as contained in the European Patent Office EDP file on
The European Patent Office is in no way liable for these particulars which are merely given for the purpose of information.

08-09-2017

Patent document cited in search report	Publication date	Patent family member(s)	Publication date
US 2011203821 A1	25-08-2011	AU 2011204260 A1	07-06-2012
		CN 102753782 A	24-10-2012
		EP 2521832 A1	14-11-2012
		GB 2490447 A	31-10-2012
		JP 2013516335 A	13-05-2013
		US 2011203821 A1	25-08-2011
		WO 2011085194 A1	14-07-2011

US 4558601 A	17-12-1985	NONE	

US 2001048855 A1	06-12-2001	CN 2420088 Y	21-02-2001
		US 2001048855 A1	06-12-2001

WO 2009136840 A1	12-11-2009	CN 102015219 A	13-04-2011
		EP 2285536 A1	23-02-2011
		JP 5315410 B2	16-10-2013
		JP 2011519742 A	14-07-2011
		US 2011079406 A1	07-04-2011
		WO 2009136840 A1	12-11-2009

EP 1878541 A2	16-01-2008	CN 201199679 Y	25-02-2009
		EP 1878541 A2	16-01-2008
		EP 2508305 A1	10-10-2012
		EP 2937187 A1	28-10-2015
		US 2008011102 A1	17-01-2008
		US 2013037288 A1	14-02-2013
		WO 2008008304 A2	17-01-2008

US 2005045354 A1	03-03-2005	CN 1600502 A	30-03-2005
		EP 1510299 A2	02-03-2005
		JP 2005066785 A	17-03-2005
		US 2005045354 A1	03-03-2005
