



(11) **EP 2 634 129 B1**

(12) **EUROPEAN PATENT SPECIFICATION**

(45) Date of publication and mention of the grant of the patent:
10.06.2015 Bulletin 2015/24

(51) Int Cl.:
B66B 1/34 (2006.01)

(21) Application number: **13157176.2**

(22) Date of filing: **28.02.2013**

(54) **Elevator system**

Aufzugssystem

Système d'ascenseur

(84) Designated Contracting States:
AL AT BE BG CH CY CZ DE DK EE ES FI FR GB GR HR HU IE IS IT LI LT LU LV MC MK MT NL NO PL PT RO RS SE SI SK SM TR

(30) Priority: **01.03.2012 JP 2012045251**

(43) Date of publication of application:
04.09.2013 Bulletin 2013/36

(73) Proprietor: **Mitsubishi Electric Corporation**
Chiyoda-ku
Tokyo 100-8310 (JP)

(72) Inventors:
• **Washio, Kazunori**
Tokyo, 100-8310 (JP)

- **Takahashi, Satoru**
Tokyo, 100-8310 (JP)
- **Kitayama, Kenji**
Tokyo, 100-8310 (JP)
- **Hamada, Kazuki**
Tokyo, 100-8310 (JP)

(74) Representative: **Hoffmann Eitle**
Patent- und Rechtsanwälte PartmbB
Arabellastraße 30
81925 München (DE)

(56) References cited:
EP-A1- 2 062 842 WO-A1-03/020625
WO-A1-2012/067001 JP-A- H10 167 599

EP 2 634 129 B1

Note: Within nine months of the publication of the mention of the grant of the European patent in the European Patent Bulletin, any person may give notice to the European Patent Office of opposition to that patent, in accordance with the Implementing Regulations. Notice of opposition shall not be deemed to have been filed until the opposition fee has been paid. (Art. 99(1) European Patent Convention).

Description

BACKGROUND OF THE INVENTION

Field of the Invention

[0001] The present invention relates to a communication technique for an elevator system.

Description of the Background Art

[0002] In a conventional elevator system, since various elevator equipments, such as switches and sensors have been individually connected to a control panel, a large number of wires have been required.

[0003] Therefore, Japanese Patent Application Publication (translation of PCT Application) No. 2002-538061 has disclosed a technique in which among various elevator equipments, those relating to safety control are connected to a bus node, and the bus node is connected to a safety controller through a safety bus, thereby reducing the number of wires.

[0004] Moreover, Japanese Patent Application Laid-Open No. 2004-48474 has disclosed a technique in which various signals for the elevator equipments are unwired, thereby reducing the number of wires.

[0005] However, in the elevator system described in Japanese Patent Application Publication (translation of PCT Application) No. 2002-538061, there is a problem that the reduction of the number of wires is insufficient, since only the signals relating to safety control are connected through the bus node (serialized). Moreover, even if the other signals were also connected through the bus node, a problem would be still raised in that elevator functions are not maintained at the time of occurrence of a communication error.

[0006] Moreover, in the elevator system described in Japanese Patent Application Laid-Open No. 2004-48474, in the case of occurrence of a communication error or in the case when radio communication becomes impossible because of a blackout or the like, elevator functions are not maintained.

[0007] Background art of interest is also disclosed in Japanese patent application with publication No. 10167599 A, specifically a monitoring device for an elevator. As starting check-up by providing an inspection switch on an elevator monitoring device so as to make an inspection mode, a microcomputer outputs a command transmitting an emergency signal to an input/output interface and a communication port, the command is delivered from the input/output interface to an input/output interface through a one-to-one transmission system, and the information is delivered to a communication port by a microcomputer. By checking that the information is transmitted from the communication port to the communication port through serial transmission, the one-to-one transmission system is checked.

SUMMARY OF THE INVENTION

[0008] The object of the present invention is to provide an elevator system that reduces wires and suppresses a loss of functions even in an abnormal state.

[0009] The present invention provides an elevator system as set out in each of claims 1 and 2. Optional features are set out in the remaining claims.

[0010] These and other objects, features, aspects and advantages of the present invention will become more apparent from the following detailed description of the present invention when taken in conjunction with the accompanying drawings.

15 BRIEF DESCRIPTION OF THE DRAWINGS

[0011]

FIG. 1 is a block diagram that shows a configuration of an elevator system in accordance with a first preferred embodiment;

FIG. 2 is a block diagram that shows a configuration of a communication controller of the first preferred embodiment;

FIG. 3 is a block diagram that shows a hardware configuration of the communication controller of the first preferred embodiment;

FIG. 4 is a view that shows a frame configuration of a transmission signal for use between the communication controllers;

FIG. 5 is a flow chart that shows a transmission process of the communication controller;

FIG. 6 is a flow chart that shows a receiving process of the communication controller; and

FIG. 7 is a block diagram that shows a configuration of an elevator system in accordance with a second preferred embodiment.

DESCRIPTION OF THE PREFERRED EMBODIMENTS

[0012] There is described in the following an elevator system which includes a first communication controller, a second communication controller and control means. The first communication controller is installed in an elevator cage, an elevating path or a platform, and connected to an elevator equipment inside the elevator cage, an elevator equipment inside the elevating path, or an elevator equipment of the platform. The second communication controller is connected to the first communication controller through a serial communication network and an individual communication line so as to perform communication. The control means is connected to the second communication controller so as to control operations of the elevator cage. The individual communication line communicates a signal individually in a manner separated from a signal communicated through the serial communication network.

[0013] With a structure in which a serial communication

network is used for connecting between the first and second communication controllers, it becomes possible to reduce the number of communication lines in comparison with a structure in which the respective elevator equipments installed in the cage are respectively connected to the control panel. Moreover, even in the case of a failure in communication by the serial communication network, it is possible to suppress a loss of functions in an abnormal state by carrying out communications using individual communication lines.

(First Preferred Embodiment)

<A. First Preferred Embodiment>

<A-1. Configuration>

[0014] FIG. 1 is a view that shows a configuration of an elevator system in a first preferred embodiment of the present invention. The elevator system includes a cage 5 and a control panel 4 that controls operations of the cage 5. The control panel 4 includes a communication controller 1a, and the cage 5 has a communication controller 1b connected with the communication controller 1a through a parallel communication-use network 2 and a serial communication-use communication line 3 installed therein. Here, although the preferred embodiment for two communication controllers is shown, the number of the communication controllers is not necessarily limited thereto, and three or more of them may be used.

[0015] In the cage 5, various elevator equipments are installed, including an interphone 13b through which voice input and output are carried out, a safety switch-sensor 15, a normal control switch-sensor 16, a monitoring camera 17, a monitor 18, a card reader 19 for a serial communication device for use in providing security functions, a door controller 20, a door motor 21, a safety shoe 22, etc.

[0016] The safety switch-sensor 15 is a switch-sensor that detects a state of the cage 5 relating to safety control, and outputs the result of detection as a safety signal. For example, a floor touch sensor, a door switch, or the like corresponds to this sensor. The normal control switch-sensor 16 is a switch-sensor that detects a state of the cage 5 not relating to the safety control, and outputs the result of detection as a normal control signal. For example, a position switch for detecting a positional plate (not shown) placed inside an elevating path, or the like corresponds to this sensor.

[0017] The door controller 20 controls the opening/closing of a door (not shown) of the cage 5 and the safety shoe 22 by driving the door motor 21.

[0018] Moreover, various elevator equipments, such as a managing board 10, a picture recording device 11, an image distribution device 12, an interphone 13a and the like, are connected to the control cable through the control panel 4, or directly connected thereto.

[0019] The managing board 10 carries out security

managements (for example, a registration permission, or the like, to a destination floor) in cooperation with the card reader 19. The picture recording device 11 records images picked up by the monitoring camera 17. The image distribution device 12 outputs an image to be displayed on the monitor 18. The interphone 13a carries out voice input and output so as to provide a communication function with the interphone 13b installed in the cage 5.

[0020] Moreover, in the control panel 4 (or a machine house, or a superintendent room, or the like), a battery 14 serving as an auxiliary power supply to be used at the time of a power loss of a main power supply due to a blackout or the like is installed, and the control device 7 and the safety control device 6 are further installed therein. These constituent components installed in the control panel 4 or the like are connected to the communication controller 1a in a completely independent manner. Additionally, among the various elevator equipments inside the control panel 4, as shown in FIG. 1, the respective constituent components except for the control device 20 may be installed in the machine house or the superintendent room outside the control panel 4. In the case where these are installed in the machine house or the superintendent room, they are connected with the communication controller 1a through the control panel 4.

[0021] The safety control device 6 and the control device 7 are connected to a hoist gear 8 and a brake 9, and by driving them, a movement of the cage 5 is controlled. Based upon information of various elevator equipments received from the communication controller 1a, the control device 7 controls a driving process of the cage 5 during normal operation.

[0022] On the other hand, based upon information of various elevator equipments received from the communication controller 1a, the safety control device 6 carries out controls relating to safety of the cage 5 (such as monitoring of an over speed or prevention of travelling with the door being open) so that in the case when any abnormal state is detected in the cage 5, at least one of the power supplies of the hoist gear 8 and the brake 9 is shut off so as to bring the cage 5 to a stop at the nearest floor or to an emergency stop.

[0023] FIG. 2 is a block diagram showing a configuration of the communication controller 1a. The communication controller 1b also has the same configuration as this. The communication controller 1a includes a network communication I/F 30, a safety signal I/F 36, a normal control signal I/F 37, a voice signal I/F 38, an image signal I/F 39 and a serial signal I/F 40 as interfaces for use in connecting with the various elevator equipments. Each of the interfaces digital/analog converts a signal from the communication controller 1a to each of the various elevator equipments, and analog/digital converts a signal from each of the various elevator equipments to the communication controller 1a. Moreover, it also carries out an encoding process, a decoding process and a protocol conversion process.

[0024] Moreover, the communication controller 1a in-

cludes a transmission unit 31, a receiving unit 32, a scheduling and systemizing unit 33, a distribution unit 34 and a safety communication unit 35. The safety communication unit 35 adds error-detection information to a safety signal received from the safety signal I/F36 in a transmission stage, and carries out an error detection based upon the error-detection information in a receiving stage. The scheduling and systemizing unit 33 determines transmission schedules of respective signals. The transmission unit 31 transmits signals from the network communication I/F 30 to the other communication controller in accordance with the transmission schedules determined by the scheduling and systemizing unit 33. The receiving unit 32 receives signals from the other communication controller through the network communication I/F 30. The distribution unit 34 distributes the signals received by the receiving unit 32 to any of the interfaces except for the safety signal I/F 36, or to the safety communication unit 35.

[0025] FIG. 3 is a view showing a hardware configuration of the communication controller 1a. The communication controller 1b has the same configuration as this. The safety communication unit 35 includes a CPU (Central Processing Unit) 51, a ROM (Read Only Memory) 52, a RAM (Random Access Memory) 53 and a WDT (Watch Dog Timer) 54. Each of various interfaces includes a DAC (Digital to Analog Converter) 55, an ADC (Analog to Digital Converter) 56, an encoder 57, a decoder 58 and a protocol conversion chip 59.

[0026] The network communication I/F 30 is composed of PHY (PHYSical layer) chips 61. The transmission unit 31, the receiving unit 32, the distribution unit 34, the scheduling and systemizing unit 33 are composed of FPGA (Field Programmable Gate Array) 60; however, CPU and ASIC (Application Specific Integrated Circuit) or CPLD (Complex Programmable Logic Device) may also be used. The DAC 55, ADC 56, encoder 57, decoder 58 and protocol conversion chip 59 may be contained in an FPGA 60. The respective parts are connected with one another through buses 62 and connection lines so that various data and signals are exchanged with one another.

<A-2. Operations>

[0027] FIG. 4 shows a frame configuration of messages communicated between the communication controllers 1a and 1b. Each message includes an address 83, a source 84, a length/type 85, a data portion 86 and a frame CRC (Cyclic Redundancy Check) codes 87. In the data portion 86, a data type 82 and a data main body including serial communication data 81, voice signals 80, image signals 79 and normal control signals 78, are stored. To a message for use in transmitting a safety signal, a safety message 71 is added in addition to the above. The safety message 71 includes an address 72, a source 73, a type 74, a sequential number 75, a safety signal 76 and a safety CRC 77. Additionally, the data

type 82 may be substituted by the length/type 85.

[0028] FIG. 5 is a view that shows a transmitting process from the communication controller 1b to the communication controller 1a. The communication controller 1b receives signals from various elevator equipments of the cage 5, and transmits the same to the communication controller 1a.

[0029] The scheduling and systemizing unit 33 sets the degree of preference, reliability and response of each of the various signals, and based upon these, preliminarily determines transmission schedules and the number of continuous transmissions of the various signals (step S1). For example, in the safety message 71, the highest degree of preference and the number of continuous transmissions are set to comparatively high levels, and in the normal control signal 78, the number of continuous transmissions is set to a comparatively low level. Moreover, in the voice signal 80 and image signal 79 having a low precedence degree, continuous transmissions are not carried out, and in the case when the bandwidth of a transmission path is insufficient, such a setting as to carry out a thinning process thereon is prepared.

[0030] The respective elevator equipments installed in the cage 5 are connected to the safety signal I/F 36, the normal control signal I/F 37, the voice signal I/F 38, the image signal I/F 39 and the serial signal I/F 40 of the communication controller 1b, and signals from the respective elevator equipments are inputted to these interfaces. Thus, the communication controller 1b is allowed to determine the type of an input signal (step S2). The types of the input signal are classified into a safety signal, a normal control signal, a voice signal, an image signal, and a serial communication. The safety signal, which represents a signal showing the state of the safety switch-sensor 15, is inputted to the safety signal I/F 36. The normal control signal, which represents a signal showing the state of the normal control switch-sensor 16, is inputted to the normal control signal I/F 37. Moreover, the voice signal, which is a signal from the interphone 13b, is inputted to the voice signal I/F 38. The image signal, which is a signal from the monitoring camera 17, is inputted to the image signal I/F 39. Moreover, the serial signal, which is a signal from the card reader 19, is inputted to the serial signal I/F 40.

[0031] Upon incorporating an input signal through each of the interfaces, the safety signal and the normal control signal are subjected to an A/D conversion (steps S3 and S5), and the voice signal and the image signal are subjected to an encoding process (steps S6 and S7). Moreover, the serial communication signal is subjected to a protocol conversion (step S8).

[0032] To the safety signal incorporated through the safety signal I/F 36 is then added error detection information in the safety communication unit 35 so that a safety message 71 is generated (step S4). For example, a safety CRC 77 and a sequence number 75 are added thereto as the error detection information so as to generate the safety message 71 (see lower portion of FIG. 3).

[0033] These respective input signals 78 to 81 and the safety message 71 are sent to the scheduling and systemizing unit 33, and stored in the data unit 86 and formed into a frame in accordance with the transmission schedule determined in the step S1 (step S9). Moreover, the frame is duplicated by the number of continuous transmissions determined in the step S1 and sent to the transmission unit 31 (step S10), and then transmitted to the network 2 through the network communication I/F 30 (step S11).

[0034] At this time, in the case when the same schedules and numbers of continuous transmissions are commonly used among a plurality of signals, those may be combined into one message and then sent. Moreover, even in the case when only the same schedules are commonly used, by matching to the highest number of continuous transmissions, those may be combined into one message and then sent.

[0035] The receiving unit 32 monitors communication errors, and counts the number of occurrences of communication errors per unit time as a communication error occurrence frequency, and determines the quality of a communication path based upon the communication error occurrence frequency. It is supposed that the relationship between the communication quality and the communication error occurrence frequency is preliminarily determined and held in the communication controller 1b. When the communication quality is varied, the receiving unit 32 notifies the scheduling and systemizing unit 33 of the information of communication quality (step S12).

[0036] Upon receipt of the notification, the scheduling and systemizing unit 33 re-determines the schedule in accordance with the communication quality (step S13). For example, in the case when the communication quality is lowered, the number of transmissions (continuous transmissions) of signals having a higher precedence degree is increased. Moreover, the number of transmissions (continuous transmissions) of signals having a lower precedence degree is reduced, or a transmission is carried out, with those signals in which no reliability is required being thinned.

[0037] In contrast, in the case when the communication quality is improved, the number of transmissions (continuous transmissions) of signals having a higher precedence is reduced, or the number of transmissions (continuous transmissions) of signals having a lower precedence is increased, or those signals that have been thinned are refrained from being thinned, or the number of thinning signals is reduced.

[0038] Next, receiving processes of the communication controller 1a will be described along a flow chart of FIG. 6. The receiving unit 32 of the communication controller 1a receives a message from the network 2 through the network communication I/F 30 (step S21). The distribution unit 34 conducts an inspection for the frame CRC 87, and determines whether or not any normal frames are present among a plurality of identical messages con-

tinuously transmitted (step S22).

[0039] If none of normal frames are present in step S22, then a determination is made as to whether or not a specified period of time has been reached (step S34), and if it has been reached, then the cage 5 is brought to an emergency stop (step S29). In this case, the communication controller 1a notifies the safety control device 6 of the fact that the cage 5 needs to be brought to an emergency stop, and the safety control device 6 shuts off the power supply for the hoist gear 8 and the brake 9 so that the cage 5 is stopped at once. Alternatively, the communication controller 1a itself may shut off the power supply for the hoist gear 8 and the brake 9. After the emergency stop, the stopped state of the cage 5 is maintained until a restoration work is carried out by the maintenance worker. In the following description, the process of the emergency stop is carried out in the same manner.

[0040] If there are any normal frames in step S22, the distribution unit 34 takes out one of those frames, and distributes data for each of signal types (step S23). Next, in step S24, the type of an input signal is determined. In the case when no safety signal has been received, the notification is given to the safety communication unit 35, and the safety communication unit 35 determines whether or not a specified period of time has been reached (step S34), and if it has been reached, then the cage 5 is brought to an emergency stop (step S29). Additionally, if the specified period of time has not been reached, a process may be carried out in which the cage 5 is made to stop at the nearest floor (step S28). In this case, the safety communication unit 35 notifies the control device 7 so as to stop the cage 5 at the nearest floor so that the control device 7 stops the cage 5 at the nearest floor. Thereafter, reactivation is carried out to attempt restoration of operations of the network 2 and the cage 5. In the case when, however, no restoration is made even after carrying out a predetermined number of times or more of reactivations, the stopped state of the cage 5 is maintained so as to wait for its restoration by the maintenance worker. In the following description, the process for stopping at the nearest floor is carried out in the same manner. In the case when a safety signal has been received, the safety message 71 is transferred to the safety communication unit 35, and in the safety communication unit 35, by using error detection information in the safety message 71, an error detection (inspection for the safety CRC 77 and the sequence number 75) is carried out (step S25). In the case when no error is detected in step S25, the safety signal is outputted to the safety control device 6 and the control device 7 through the safety signal I/F 36 (step S26), and the sequence returns to step S21 to receive the next message.

[0041] If any error is detected in step S25, a determination is made as to whether or not the number of error detections has reached a predetermined number of times (step S27), and if the predetermined number has not been reached, the cage 5 is made to stop at the nearest floor (step S28).

[0042] Moreover, when the number of error detections has reached a specified number of times in step S27, the cage 5 is brought to an emergency stop (step S29).

[0043] In the case of a signal other than the safety signal, the corresponding signal is outputted to various elevator equipments through the interfaces 37 to 40 for various signals. For example, a normal control signal is D/A converted in the normal control signal I/F 37 (step S30), and then outputted to the control device 7. Moreover, a voice signal is decoded in the voice signal I/F 38 (step S31), and then outputted to the interphone 13a or the like. Furthermore, an image signal is decoded in the image signal I/F 39 (step S32), and then outputted to the picture recording device 11 or the like. A serial signal is protocol-converted in the serial signal I/F 40 (step S33), and then outputted to various elevator equipments, such as the managing board 10.

[0044] The safety communication unit 35 has also self-diagnosis functions, such as an inspection for CPU 51 by a self-testing program, a time monitoring process during execution by the WDT 54, a read/write inspection of the RAM 53, a CRC inspection of the ROM 52, comparisons of input/output signals of a double system and a monitoring process of an input/output signal by back reading of an output signal, and ensures high reliability in dealing with information relating to safety control. Additionally, the safety communication unit 35 may be provided with redundancy.

[0045] Upon detection of a failure of its own by the self-diagnosis functions, the safety communication unit 35 notifies the safety control device 6 or the like of the failure. In the case when the failure of the safety communication unit 35 is a temporary minor failure caused by a garbled bit or the like, the safety control device 6 brings the cage 5 to a stop at the nearest floor, while in the case when the failure is a serious failure such as fixation of an output signal or the like, it brings the cage 5 to an emergency stop.

[0046] The present specification has given explanations by exemplifying the structure in which information of the elevator equipments installed in the cage 5 is transmitted from the communication controller 1b to the communication controller 1a and then outputted to elevator equipments connected to the control panel 4. However, in the case when communication is carried out in a reversed direction, such as a transmission of a control signal from the control device 7 to the door controller 20 or a transmission of an image signal from the image distribution device 12 to the monitor 18, the processes in the both of the communication controllers 1a and 1b can be simply reversed. In this case, an occurrence of a communication error is informed to the communication controller 1a on the control panel 4 side from the communication controller 1b by using an individual communication line 3, and based upon the contents thereof, the cage 5 may be continuously operated, or brought to a stop at the nearest floor, or brought to an emergency stop by the safety control device 6 and the control device 7 (or an

instruction may be given to the safety control device 6 and the control device 7 so as to continue the operation, or make a stop at the nearest floor, or make an emergency stop by using the individual communication line 3). Alternatively, in the case when the safety control device and the control device are connected to the communication controller 1b and installed in the cage 5 as control means on the cage side for controlling the operations of the cage 5, based upon the contents of a communication error in the communication controller 1b and the kinds of communication information, the cage 5 can be brought to a stop at the nearest floor, or brought to an emergency stop, by the safety control device and the control device of the cage 5.

[0047] Moreover, communications between the communication controllers 1 were carried out through the network 2. However, in the case when the communication of the network 2 is impossible because of a failure or the like of the communication circuit, it is possible to carry out communication of a minimum required signal for a normal operation of the elevator, such as a part of the safety signal or the like, by using a one-to-one communication by the use of the communication line 3. Of course, in the case when the communication carried out by the network 2 is normal, the one-to-one communication by the communication line 3 may be used in combination.

[0048] Conventionally, with respect to the communication lines that connect various devices with one another in an elevator system, a total number of 70 lines were required. Those lines are classified into about 20 lines for the safety switch-sensor 15, about 20 lines for the normal control switch-sensor 16, about 5 lines each for the card reader 19 for use in providing security functions, for the managing board 10, for the interphones 13a and 13b, for the monitoring camera 17 and for the monitor 18, and about 10 lines for the door controller 20.

[0049] In accordance with the elevator system of the present preferred embodiment, the number of communication lines can be reduced to a total of 24 lines, that is, 4 lines required for the network 2 (the twist pair entire double communication), and about 20 communication lines that are minimum required for the operations of an elevator. Additionally, the number is not limited thereto, depending on the structures of the elevator.

[0050] Moreover, in the elevator system of the present preferred embodiment, the battery 14 serving as an auxiliary power supply is installed in the control panel 4 (or in the machine house, the superintendent room, or the like); therefore, even in the case of a power loss of the main power supply at a blackout or the like, the communication can be continued by making a switch to the auxiliary power supply. At this time, only the communication that is minimum required for maintaining functions of the elevator at the time of the blackout is continuously maintained, such as communications for signal or the like required for rescuing passengers trapped therein, that is, the signal or the like from, for example, the interphone

13 and the emergency notifying device, or the like. With respect to functions relating to communications except for this, power supplies are shut off, or brought to a power-saving mode. In the case when the main power supply is restored, a switching is made to the main power supply, and all the communications are restored. Additionally, the battery 14 may be installed in each of the communication controllers 1a and 1b, or a common battery 14 may be utilized, with a power supply line being connected between the communication controllers 1a and 1b.

<A-3. Effects>

[0051] The elevator system of the present preferred embodiment includes a first communication controller (communication controller 1b) that is installed in an elevator cage (cage 5) or at an elevating path or a platform, and is connected to elevator equipments in the cage 5, the elevating path or the platform; a second communication controller (communication controller 1a) that is connected to the communication controller 1b by a serial communication network (network 2) and an individual communication line (communication line 3) and carries out communications; and control means (safety control device 6, control device 7) that is connected to the communication controller 1a, and controls operations of the cage 5 in which the communication line 3 communicates a signal individually in a separate manner from a signal that is communicated through the network 2. With the structure in which the network 2 is used for connecting between the communication controllers 1a and 1b, it becomes possible to reduce the number of communication lines in comparison with a structure in which the respective elevator equipments installed in the cage or the like are respectively connected to the control panel. Moreover, even in the case of a failure in communication by the network 2, communications having a high degree of importance, such as, for example, a safety signal or the like, can be positively carried out by carrying out communications using individual communication lines. That is, in accordance with the elevator system of the present preferred embodiment, the number of wires can be reduced, while preventing the loss of functions upon occurrence of an abnormal state.

[0052] Moreover, based upon a transmission schedule in accordance with the degree of precedence of a transmission signal in the network 2, the communication controllers 1a and 1b transmit the transmission signal; therefore, communications for a signal having a higher precedence degree, such as a signal relating to safety control, can be positively carried out.

[0053] Moreover, since the communication controllers 1a and 1b monitor a communication error in the network 2 and determine the schedule for the transmission signal based upon a frequency of the communication error, it is possible to carry out a network communication in accordance with the communication quality.

[0054] Furthermore, since the communication control-

lers 1a and 1b determine the schedule for a transmission signal depending on a usable bandwidth of the communication path in the network 2, network communications can be carried out in accordance with communication quality.

[0055] In the case when information relating to safety control is communicated, the communication controllers 1a and 1b add error detection information to the information relating to safety control at the time of transmitting, and carry out an error detection by using the error detection information at the time of receiving so that it is possible to ensure reliability of communications required for safety control.

[0056] Upon occurrence of a communication error, the communication controller 1a determines the contents of the communication error and the kinds of communication information, and the safety control device 6 and the control device 7 allow the cage 5 to continue operations, or bring the cage to a stop at the nearest floor, or to an emergency stop based upon the determination of the communication controller 1a, so that even at the time of a communication error, the safety of the elevator cage 5 can be ensured.

[0057] Moreover, the occurrence of a communication error is informed to the communication controller 1a on the control panel 4 side from the communication controller 1b by using the individual communication line 3, and based upon the contents thereof, the cage 5 is continuously operated, or brought to a stop at the nearest floor, or brought to an emergency stop by the safety control device 6 and the control device 7 (or an instruction is given to the safety control device 6 and the control device 7 so as to continue the operation, or make a stop at the nearest floor, or make an emergency stop by using the individual communication line 3). Alternatively, in the case when the safety control device and the control device are connected to the communication controller 1b and installed in the cage 5 as control means on the cage side for controlling the operations of the cage 5, upon occurrence of a communication error, the communication controller 1b determines the contents of the communication error and the kinds of communication information, and the safety control device and the control device allow the cage 5 to continue the operations, or bring the cage 5 to a stop at the nearest floor or to an emergency stop based upon the determination of the communication controller 1b. With the above-mentioned operations, it becomes possible to ensure the safety of the elevator cage 5 even at the time of a communication error.

[0058] Moreover, since the elevator system in accordance with the present preferred embodiment further includes an auxiliary power supply for supplying power at the time of power loss of the main power supply, it is possible to ensure reliability that is minimum required for the elevator communication by carrying out communications having a high precedence degree by using the auxiliary power supply.

<B. Second Preferred Embodiment>

[0059] FIG. 7 is a block diagram that shows a configuration of an elevator system in accordance with a second preferred embodiment of the present invention. The elevator system of the second preferred embodiment further includes a communication controller 1c installed in an elevating path 23, an elevating path switch 25, a door switch 24 at the platform and a safety control device 6c in addition to the configuration of the elevator system 2 of the first preferred embodiment.

[0060] In the elevator system of the present preferred embodiment, a communication controller and a safety control device are installed in each of the control panel 4, the cage 5 and the elevating path 23, and these safety control devices individually carry out safety controls. At this time, the respective communication controllers 1a, 1b and 1c mutually communicate information of elevator equipments that are respectively connected thereto so that safety control devices 6a, 6b and 6c that are respectively connected with the communication controllers 1a, 1b and 1c are allowed to carry out safety controls while sharing pieces of information of the elevator equipments.

[0061] For example, results of detections from the door switch 24 at a platform and the elevating path switch 25 are transmitted from the communication controller 1c installed at the elevating path, and by allowing these to be received by the communication controller 1b of the cage 5, it is possible to provide such a safety control that an emergency stop 26 installed in the cage 5 is activated upon detection of an unintended movement of the cage 5.

[0062] Moreover, by allowing the safety control devices 6a, 6b and 6c to exchange data among them, mutual monitoring processes are available so that upon occurrence of a failure in any one of the safety control devices, the movement of the cage 5 can be stopped by using another safety control device so that a backup operation of safety control can be executed. That is, in accordance with the present preferred embodiment, it is possible to further improve the functions of the safety control device upon occurrence of an abnormal state, while reducing the number of wires of the elevator.

[0063] Additionally, in any of the preferred embodiments, the safety communication unit 35 and the safety signal interface 36 of each of the communication controllers 1a, 1b and 1c may be included in each of the safety control devices 6, 6a, 6b and 6c. Moreover, information to be added to a safety signal by the safety communication unit 35 may be any information other than CRC codes, and even when parity bits, BCH codes, Reed-Solomon codes, error-correction codes or the like are used, the same effects can be obtained.

[0064] While the invention has been shown and described in detail, the foregoing description is in all aspects illustrative and not restrictive. It is therefore understood that numerous modifications and variations can be devised without departing from the scope of the invention.

Claims

1. An elevator system comprising:

a first communication controller (1b) that is installed in an elevator cage (5), an elevating path or a platform, and connected to an elevator equipment inside said elevator cage (5), an elevator equipment inside said elevating path or an elevator equipment of said platform; a second communication controller (1a) that is connected to said first communication controller (1b) through a serial communication network (2) and an individual communication line (3) so as to perform communication; and control means (6, 7) that is connected to said second communication controller (1a) so as to control operations of said elevator cage (5), wherein said individual communication line (3) is arranged to communicate a signal individually in a manner separated from a signal communicated through said serial communication network (2),

characterised in that said second communication controller (1a) is arranged to determine contents of a communication error and kinds of communication information upon occurrence of the communication error, and said control means (6, 7) is arranged to allow said elevator cage (5) to continue operations, or bring said elevator cage (5) to a stop at the nearest floor, or to an emergency stop based upon the determination of said second communication controller (1a).

2. An elevator system comprising:

a first communication controller (1b) that is installed in an elevator cage (5), an elevating path or a platform, and connected to an elevator equipment inside said elevator cage (5), an elevator equipment inside said elevating path or an elevator equipment of said platform; a second communication controller (1a) that is connected to said first communication controller (1b) through a serial communication network (2) and an individual communication line (3) so as to perform communication; and control means (6, 7) that is connected to said second communication controller (1a) so as to control operations of said elevator cage (5), wherein said individual communication line (3) is arranged to communicate a signal individually in a manner separated from a signal communicated through said serial communication network (2),

characterised in that said first communication controller (1b) is arranged to determine contents

- of a communication error and kinds of communication information upon occurrence of the communication error in said serial communication network (2), and based upon the determination, give an instruction to said second communication controller (1a) by using said individual communication line (3) so as to allow said elevator cage (5) to continue operations, or bring said elevator cage (5) to a stop at the nearest floor, or to an emergency stop, and said control means (6, 7) is arranged to allow said elevator cage (5) to continue operations, or bring said elevator cage (5) to a stop at the nearest floor, or to an emergency stop based upon said instruction received by said second communication controller (1a) from said first communication controller (1b).
3. The elevator system according to claim 1 or claim 2, wherein said first and second communication controllers (1a, 1b) are arranged to transmit the transmission signal based upon a transmission schedule in accordance with a precedence degree of a transmission signal in said serial communication network (2).
 4. The elevator system according to any preceding claim, wherein said first and second communication controllers (1a, 1b) are arranged to perform communication by using said individual communication line (3) when communication by said serial communication network (2) is impossible.
 5. The elevator system according to any preceding claim, wherein said first and second communication controllers (1a, 1b) are arranged to monitor a communication error of said serial communication network (2) and determine a schedule for a transmission signal based upon a frequency of the communication error.
 6. The elevator system according to any preceding claim, wherein said first and second communication controllers (1a, 1b) are arranged to determine a schedule for a transmission signal based upon a usable bandwidth of a communication path in said serial communication network (2).
 7. The elevator system according to any preceding claim, wherein upon communicating information relating to safety control, said first and second communication controllers (1a, 1b) are arranged to add error detection information to the information relating to safety control at the time of transmitting, and carry out an error detection by using said error detection information at the time of receiving.
 8. The elevator system according to claim 1, wherein said first communication controller (1b) is arranged to transmit contents of a communication error and kinds of communication information to said second communication controller (1a) by using said individual communication line (3) upon occurrence of the communication error in said serial communication network (2).
 9. The elevator system according to claim 1, or any one of claims 3 to 7 when dependent on claim 1, further comprising:
 - second control means (6b) that is connected to said first communication controller (1b) so as to control operations of said elevator cage (5), wherein said first communication controller (1b) is arranged to determine contents of a communication error and kinds of communication information upon occurrence of the communication error, and said second control means (6b) is arranged to allow said elevator cage (5) to continue operations, or bring said elevator cage (5) to a stop at the nearest floor, or to an emergency stop based upon the determination of said first communication controller (1b).
 10. The elevator system according to any preceding claim, further comprising: an auxiliary power supply (14) for supplying electric power at the time of a power loss of a main power supply.

Patentansprüche

1. Ein Aufzugssystem umfassend:

- eine erste Kommunikationssteuereinheit (1b), welche in einer Aufzugskabine (5), einem Aufzugspfad oder einer Plattform installiert und mit einem Aufzugsgerät innerhalb der Aufzugskabine (5), einem Aufzugsgerät innerhalb des Aufzugspfads oder einem Aufzugsgerät der Plattform verbunden ist;
 - eine zweite Kommunikationssteuereinheit (1a), welche mit der ersten Kommunikationssteuereinheit (1b) über ein serielles Kommunikationsnetzwerk (2) und eine individuelle Kommunikationsleitung (3) verbunden ist, um eine Kommunikation auszuführen; und
 - Steuermittel (6,7), welche mit der zweiten Kommunikationssteuereinheit (1a) verbunden sind, um Betriebsvorgänge der Aufzugskabine (5) zu steuern,
- wobei die individuelle Kommunikationsleitung (3) zum individuellen Kommunizieren eines Signals in einer von einem über das serielle Kommunikationsnetzwerk (2) kommunizierten Sig-

nal getrennten Weise angeordnet ist, **dadurch gekennzeichnet, dass** die zweite Kommunikationssteuereinheit (1a) zum Bestimmen von Inhalten eines Kommunikationsfehlers und Arten von Kommunikationsinformationen auf ein Auftreten des Kommunikationsfehlers angeordnet ist, und die Steuermittel (6,7) angeordnet sind zum Erlauben der Aufzugskabine (5) Betriebsvorgänge weiter auszuführen oder die Aufzugskabine (5) zu einem Halt an dem nächsten Stockwerk oder zu einem Nothalt zu bringen, basierend auf der Bestimmung der zweiten Kommunikationssteuereinheit (1a).

2. Ein Aufzugssystem umfassend:

eine erste Kommunikationssteuereinheit (1b), welche in einer Aufzugskabine (5), einem Aufzugspfad oder einer Plattform installiert und mit einem Aufzugsgerät innerhalb der Aufzugskabine (5), einem Aufzugsgerät innerhalb des Aufzugspfads oder einem Aufzugsgerät der Plattform verbunden ist;

eine zweite Kommunikationssteuereinheit (1a), welche mit der ersten Kommunikationssteuereinheit (1b) über ein serielles Kommunikationsnetzwerk (2) und eine individuelle Kommunikationsleitung (3) verbunden ist, um eine Kommunikation auszuführen; und

Steuermittel (6,7), welche mit der zweiten Kommunikationssteuereinheit (1a) verbunden sind, um Betriebsvorgänge der Aufzugskabine (5) zu steuern,

wobei die individuelle Kommunikationsleitung (3) zum individuellen Kommunizieren eines Signals in einer von einem über das serielle Kommunikationsnetzwerk (2) kommunizierten Signal getrennten Weise angeordnet ist,

dadurch gekennzeichnet, dass die erste Kommunikationssteuereinheit (1b) angeordnet ist zum Bestimmen von Inhalten eines Kommunikationsfehlers und Arten von Kommunikationsinformationen auf ein Auftreten des Kommunikationsfehlers in dem seriellen Kommunikationsnetzwerk (2) und basierend auf der Bestimmung zum Ausgeben einer Anweisung an die zweite Kommunikationssteuereinheit (1a) durch Verwenden der individuellen Kommunikationsleitung (3), um der Aufzugskabine (5) zu erlauben Betriebsvorgänge weiter auszuführen, oder die Aufzugskabine (5) zu einem Halt an dem nächsten Stockwerk oder zu einem Nothalt zu bringen, und

die Steuermittel (6,7) angeordnet sind zum Erlauben der Aufzugskabine (5) Betriebsvorgänge weiter auszuführen oder die Aufzugskabine (5) zu einem Halt an dem nächsten Stockwerk oder

zu einem Nothalt zu bringen, basierend auf der durch die zweite Kommunikationssteuereinheit (1a) von der ersten Kommunikationssteuereinheit (1b) empfangenen Anweisung.

- 5 3. Das Aufzugssystem gemäß Anspruch 1 oder Anspruch 2, wobei die ersten und zweiten Kommunikationssteuereinheiten (1a, 1b) zum Senden des Sendesignals basierend auf einem Sendepfad gemäß einem Vorranggrad eines Sendesignals in dem seriellen Kommunikationsnetzwerk (2) angeordnet sind.
- 10 4. Das Aufzugssystem gemäß einem der vorstehenden Ansprüche, wobei die ersten und zweiten Kommunikationssteuereinheiten (1a, 1b) zum Ausführen einer Kommunikation durch Verwenden der individuellen Kommunikationsleitung (3) angeordnet sind, wenn eine Kommunikation über das serielle Kommunikationsnetzwerk (2) unmöglich ist.
- 15 5. Das Aufzugssystem gemäß einem der vorstehenden Ansprüche, wobei die ersten und zweiten Kommunikationssteuereinheiten (1a, 1b) zum Überwachen eines Kommunikationsfehlers des seriellen Kommunikationsnetzwerks (2) und zum Bestimmen eines Plans für ein Sendesignal basierend auf einer Frequenz des Kommunikationsfehlers angeordnet sind.
- 20 6. Das Aufzugssystem gemäß einem der vorstehenden Ansprüche, wobei die ersten und zweiten Kommunikationssteuereinheiten (1a, 1b) zum Bestimmen eines Plans für ein Sendesignal basierend auf einer nutzbaren Bandbreite eines Kommunikationspfads in dem seriellen Kommunikationsnetzwerk (2) angeordnet sind.
- 25 7. Das Aufzugssystem gemäß einem der vorstehenden Ansprüche, wobei auf eine Kommunikationsinformation betreffend eine Sicherheitssteuerung die ersten und zweiten Kommunikationssteuereinheiten (1a, 1b) zum Hinzufügen von Fehlererkennungsinformationen zu den Informationen betreffend eine Sicherheitssteuerung zum Zeitpunkt eines Sendens und zum Ausführen einer Fehlererkennung durch Verwenden der Fehlererkennungsinformation zu dem Zeitpunkt eines Empfangens angeordnet sind.
- 30 8. Das Aufzugssystem gemäß Anspruch 1, wobei die erste Kommunikationssteuereinheit (1b) zum Senden von Inhalten eines Kommunikationsfehlers und Arten von Kommunikationsinformationen zu der zweiten Kommunikationssteuereinheit (1a) durch Verwenden der individuellen Kommunikationsleitung (3) auf ein Auftreten des Kommunikationsfehlers in dem seriellen Kommunikationsnetzwerk (2) angeordnet ist.
- 35 9. Das Aufzugssystem gemäß Anspruch 1, wobei die erste Kommunikationssteuereinheit (1b) zum Bestimmen von Inhalten eines Kommunikationsfehlers und Arten von Kommunikationsinformationen auf ein Auftreten des Kommunikationsfehlers in dem seriellen Kommunikationsnetzwerk (2) und basierend auf der Bestimmung zum Ausgeben einer Anweisung an die zweite Kommunikationssteuereinheit (1a) durch Verwenden der individuellen Kommunikationsleitung (3), um der Aufzugskabine (5) zu erlauben Betriebsvorgänge weiter auszuführen, oder die Aufzugskabine (5) zu einem Halt an dem nächsten Stockwerk oder zu einem Nothalt zu bringen, und die Steuermittel (6,7) angeordnet sind zum Erlauben der Aufzugskabine (5) Betriebsvorgänge weiter auszuführen oder die Aufzugskabine (5) zu einem Halt an dem nächsten Stockwerk oder
- 40 10. Das Aufzugssystem gemäß Anspruch 1, wobei die erste Kommunikationssteuereinheit (1b) zum Bestimmen von Inhalten eines Kommunikationsfehlers und Arten von Kommunikationsinformationen auf ein Auftreten des Kommunikationsfehlers in dem seriellen Kommunikationsnetzwerk (2) und basierend auf der Bestimmung zum Ausgeben einer Anweisung an die zweite Kommunikationssteuereinheit (1a) durch Verwenden der individuellen Kommunikationsleitung (3), um der Aufzugskabine (5) zu erlauben Betriebsvorgänge weiter auszuführen, oder die Aufzugskabine (5) zu einem Halt an dem nächsten Stockwerk oder zu einem Nothalt zu bringen, und die Steuermittel (6,7) angeordnet sind zum Erlauben der Aufzugskabine (5) Betriebsvorgänge weiter auszuführen oder die Aufzugskabine (5) zu einem Halt an dem nächsten Stockwerk oder
- 45 11. Das Aufzugssystem gemäß Anspruch 1, wobei die erste Kommunikationssteuereinheit (1b) zum Bestimmen von Inhalten eines Kommunikationsfehlers und Arten von Kommunikationsinformationen auf ein Auftreten des Kommunikationsfehlers in dem seriellen Kommunikationsnetzwerk (2) und basierend auf der Bestimmung zum Ausgeben einer Anweisung an die zweite Kommunikationssteuereinheit (1a) durch Verwenden der individuellen Kommunikationsleitung (3), um der Aufzugskabine (5) zu erlauben Betriebsvorgänge weiter auszuführen, oder die Aufzugskabine (5) zu einem Halt an dem nächsten Stockwerk oder zu einem Nothalt zu bringen, und die Steuermittel (6,7) angeordnet sind zum Erlauben der Aufzugskabine (5) Betriebsvorgänge weiter auszuführen oder die Aufzugskabine (5) zu einem Halt an dem nächsten Stockwerk oder
- 50 12. Das Aufzugssystem gemäß Anspruch 1, wobei die erste Kommunikationssteuereinheit (1b) zum Bestimmen von Inhalten eines Kommunikationsfehlers und Arten von Kommunikationsinformationen auf ein Auftreten des Kommunikationsfehlers in dem seriellen Kommunikationsnetzwerk (2) und basierend auf der Bestimmung zum Ausgeben einer Anweisung an die zweite Kommunikationssteuereinheit (1a) durch Verwenden der individuellen Kommunikationsleitung (3), um der Aufzugskabine (5) zu erlauben Betriebsvorgänge weiter auszuführen, oder die Aufzugskabine (5) zu einem Halt an dem nächsten Stockwerk oder zu einem Nothalt zu bringen, und die Steuermittel (6,7) angeordnet sind zum Erlauben der Aufzugskabine (5) Betriebsvorgänge weiter auszuführen oder die Aufzugskabine (5) zu einem Halt an dem nächsten Stockwerk oder
- 55 13. Das Aufzugssystem gemäß Anspruch 1, wobei die erste Kommunikationssteuereinheit (1b) zum Bestimmen von Inhalten eines Kommunikationsfehlers und Arten von Kommunikationsinformationen auf ein Auftreten des Kommunikationsfehlers in dem seriellen Kommunikationsnetzwerk (2) und basierend auf der Bestimmung zum Ausgeben einer Anweisung an die zweite Kommunikationssteuereinheit (1a) durch Verwenden der individuellen Kommunikationsleitung (3), um der Aufzugskabine (5) zu erlauben Betriebsvorgänge weiter auszuführen, oder die Aufzugskabine (5) zu einem Halt an dem nächsten Stockwerk oder zu einem Nothalt zu bringen, und die Steuermittel (6,7) angeordnet sind zum Erlauben der Aufzugskabine (5) Betriebsvorgänge weiter auszuführen oder die Aufzugskabine (5) zu einem Halt an dem nächsten Stockwerk oder

9. Das Aufzugssystem gemäß Anspruch 1 oder einem der Ansprüche 3 bis 7, wenn diese von Anspruch 1 abhängen, weiter umfassend:

zweite Steuermittel (6b), welche mit der ersten Kommunikationssteuereinheit (1b) verbunden ist, um Betriebsvorgänge der Aufzugskabine (5) zu steuern, wobei die erste Kommunikationssteuereinheit (1b) zum Bestimmen von Inhalten eines Kommunikationsfehlers und Arten von Kommunikationsinformationen auf ein Auftreten des Kommunikationsfehlers angeordnet ist, und die zweiten Steuermittel (6b) zum Erlauben der Aufzugskabine (5) Betriebsvorgänge weiter auszuführen oder die Aufzugskabine (5) zu einem Halt an dem nächsten Stockwerk oder zu einem Nothalt zu bringen, basierend auf der Bestimmung der ersten Kommunikationssteuereinheit (1b) angeordnet ist.

10. Das Aufzugssystem gemäß einem der vorstehenden Ansprüche weiter umfassend: eine Hilfsenergieversorgung (14) zum Zuführen von elektrischer Energie zu dem Zeitpunkt eines Energieverlusts einer Hauptenergieversorgung.

Revendications

1. Système d'ascenseur comprenant :

un premier dispositif de commande de communication (1b) qui est monté dans une cage d'ascenseur (5), un trajet ou une plateforme élévateur, et raccordé à un équipement d'ascenseur à l'intérieur de ladite cage d'ascenseur (5), un équipement d'ascenseur à l'intérieur dudit trajet élévateur ou un équipement d'ascenseur de ladite plateforme ;
un deuxième dispositif de commande de communication (1a) qui est raccordé audit premier dispositif de commande de communication (1b) par l'intermédiaire d'un réseau de communication en série (2) et une ligne de communication individuelle (3) de manière à réaliser la communication ; et
des moyens de commande (6, 7) qui sont raccordés audit deuxième dispositif de commande de communication (1a) de manière à commander des opérations de ladite cage d'ascenseur (5),
dans lequel ladite ligne de communication individuelle (3) est disposée pour communiquer un signal individuellement de manière distincte d'un signal communiqué par l'intermédiaire dudit réseau de communication en série (2),
caractérisé en ce que ledit deuxième dispositif

de commande de communication (1a) est disposé pour déterminer le contenu d'une erreur de communication et des types d'informations de communication lors de l'apparition de l'erreur de communication, et
lesdits moyens de commande (6, 7) sont disposés pour permettre à ladite cage d'ascenseur (5) de continuer des opérations, ou amener ladite cage d'ascenseur (5) à un arrêt à l'étage le plus proche, ou à un arrêt d'urgence basé sur la détermination dudit deuxième dispositif de commande de communication (1a).

2. Système d'ascenseur comprenant :

un premier dispositif de commande de communication (1b) qui est monté dans une cage d'ascenseur (5), un trajet ou une plateforme élévateur, et raccordé à un équipement d'ascenseur à l'intérieur de ladite cage d'ascenseur (5), un équipement d'ascenseur à l'intérieur dudit trajet élévateur ou un équipement d'ascenseur de ladite plateforme ;
un deuxième dispositif de commande de communication (1a) qui est raccordé audit premier dispositif de commande de communication (1b) par l'intermédiaire d'un réseau de communication en série (2) et une ligne de communication individuelle (3) de manière à réaliser la communication ; et
des moyens de commande (6, 7) qui sont raccordés audit deuxième dispositif de commande de communication (1a) de manière à commander des opérations de ladite cage d'ascenseur (5),
dans lequel ladite ligne de communication individuelle (3) est disposée pour communiquer un signal individuellement d'une manière distincte d'un signal communiqué par l'intermédiaire dudit réseau de communication en série (2),
caractérisé en ce que ledit premier dispositif de commande de communication (1b) est disposé pour déterminer le contenu d'une erreur de communication et des types d'informations de communication lors de l'apparition de l'erreur de communication dans ledit réseau de communication en série (2), et sur la base de la détermination, donner une instruction audit deuxième dispositif de commande de communication (1a) en utilisant ladite ligne de communication individuelle (3) de manière à permettre à ladite cage d'ascenseur (5) de poursuivre des opérations, ou d'amener ladite cage d'ascenseur (5) à un arrêt à l'étage le plus proche, ou à un arrêt d'urgence, et
lesdits moyens de commande (6, 7) sont disposés pour permettre à ladite cage d'ascenseur (5) de poursuivre des opérations, ou d'amener

- ladite cage d'ascenseur (5) à un arrêt à l'étage le plus proche, ou à un arrêt d'urgence basé sur ladite instruction reçue par ledit deuxième dispositif de commande de communication (1a) dudit premier dispositif de commande de communication (1b). 5
3. Système d'ascenseur selon la revendication 1 ou la revendication 2, dans lequel lesdits premier et deuxième dispositifs de commande de communication (1a, 1b) sont disposés pour transmettre le signal de transmission basé sur un programme de transmission conformément à un degré de priorité d'un signal de transmission dans ledit réseau de communication en série (2). 10
4. Système d'ascenseur selon l'une quelconque des revendications précédentes, dans lequel lesdits premier et deuxième dispositifs de commande de communication (1a, 1b) sont disposés pour réaliser la communication en utilisant ladite ligne individuelle de communication (3) lorsque la communication par ledit réseau de communication en série (2) est impossible. 20
5. Système d'ascenseur selon l'une quelconque des revendications précédentes, dans lequel lesdits premier et deuxième dispositifs de commande de communication (1a, 1b) sont disposés pour surveiller une erreur de communication dudit réseau de communication en série (2) et déterminer un programme pour un signal de transmission basé sur une fréquence de l'erreur de communication. 25
6. Système d'ascenseur selon l'une quelconque des revendications précédentes, dans lequel lesdits premier et deuxième dispositifs de commande de communication (1a, 1b) sont disposés pour déterminer un programme pour un signal de transmission basé sur une largeur de bande utilisable d'un trajet de communication dans ledit réseau de communication en série (2). 30
7. Système d'ascenseur selon l'une quelconque des revendications précédentes, dans lequel lors de la communication d'informations concernant une commande de sécurité, lesdits premier et deuxième dispositifs de commande de communication (1a, 1b) sont disposés pour ajouter des informations de détection d'erreur aux informations concernant la commande de sécurité au moment de la transmission, et effectuer une détection d'erreur en utilisant lesdites informations de détection d'erreur au moment de la réception. 40
8. Système d'ascenseur selon la revendication 1, dans lequel ledit premier dispositif de commande de communication (1b) est disposé pour transmettre le contenu d'une erreur de communication et des types d'informations de communication audit deuxième dispositif de commande de communication (1a) en utilisant ladite ligne de communication individuelle (3) lors de l'apparition de l'erreur de communication dans ledit réseau de communication en série (2). 50
9. Système d'ascenseur selon la revendication 1, ou l'une quelconque des revendications 3 à 7 si dépendantes de la revendication 1, comprenant en outre :
des deuxièmes moyens de commande (6b) qui sont raccordés audit premier dispositif de commande de communication (1b) de manière à commander des opérations de ladite cage d'ascenseur (5), dans lequel ledit premier dispositif de commande de communication (1b) est disposé pour déterminer le contenu d'une erreur de communication et des types d'informations de communication lors de l'apparition de l'erreur de communication, et lesdits deuxièmes moyens de commande (6b) sont disposés pour permettre à ladite cage d'ascenseur (5) de poursuivre des opérations, ou d'amener ladite cage d'ascenseur (5) à un arrêt à l'étage le plus proche, ou à un arrêt d'urgence basé sur la détermination dudit premier dispositif de commande de communication (1b). 55
10. Système d'ascenseur selon l'une quelconque des revendications précédentes, comprenant en outre : une alimentation électrique auxiliaire (14) pour approvisionner en courant électrique au moment d'une perte de courant d'une alimentation électrique principale. 55

FIG. 1

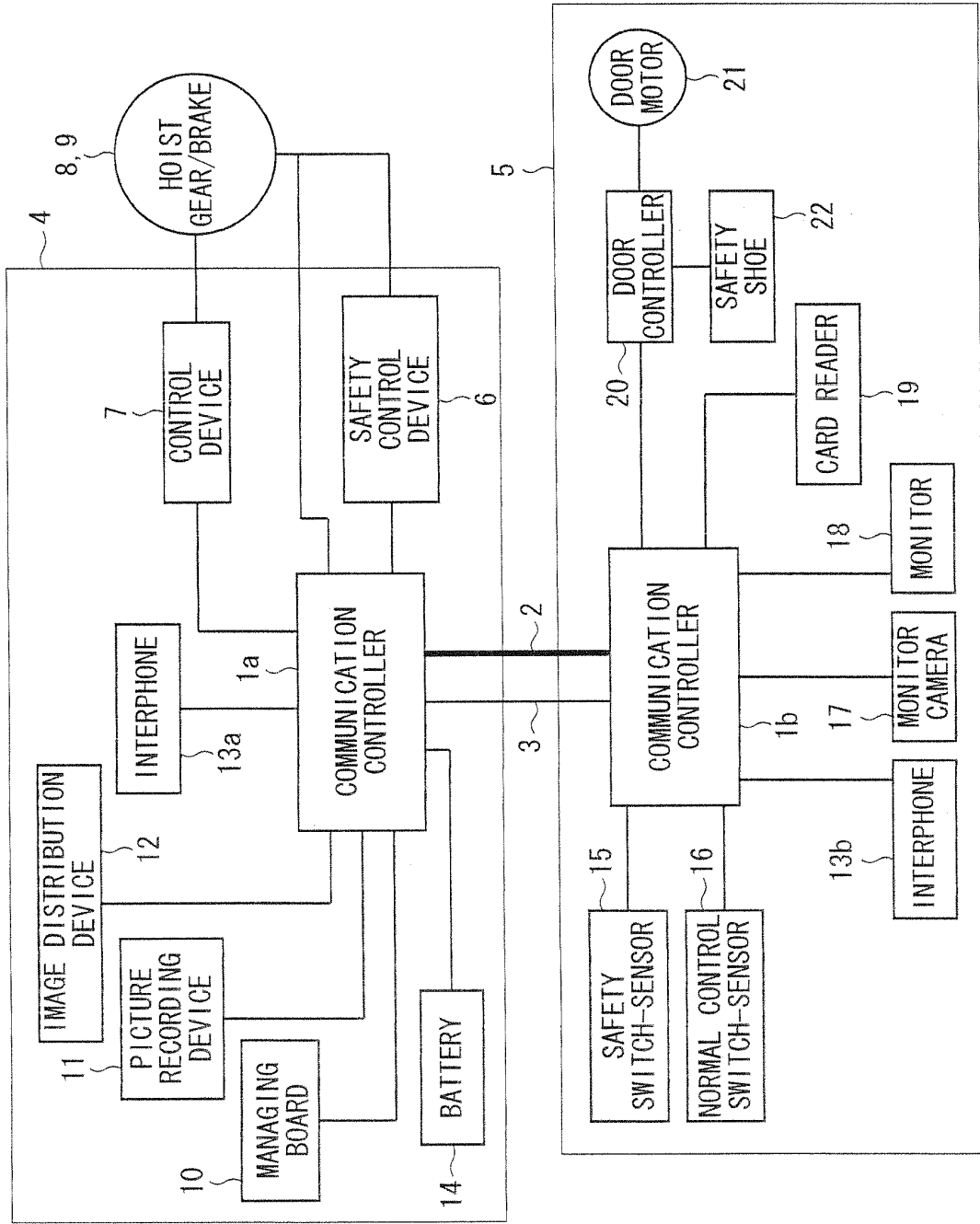

FIG. 2

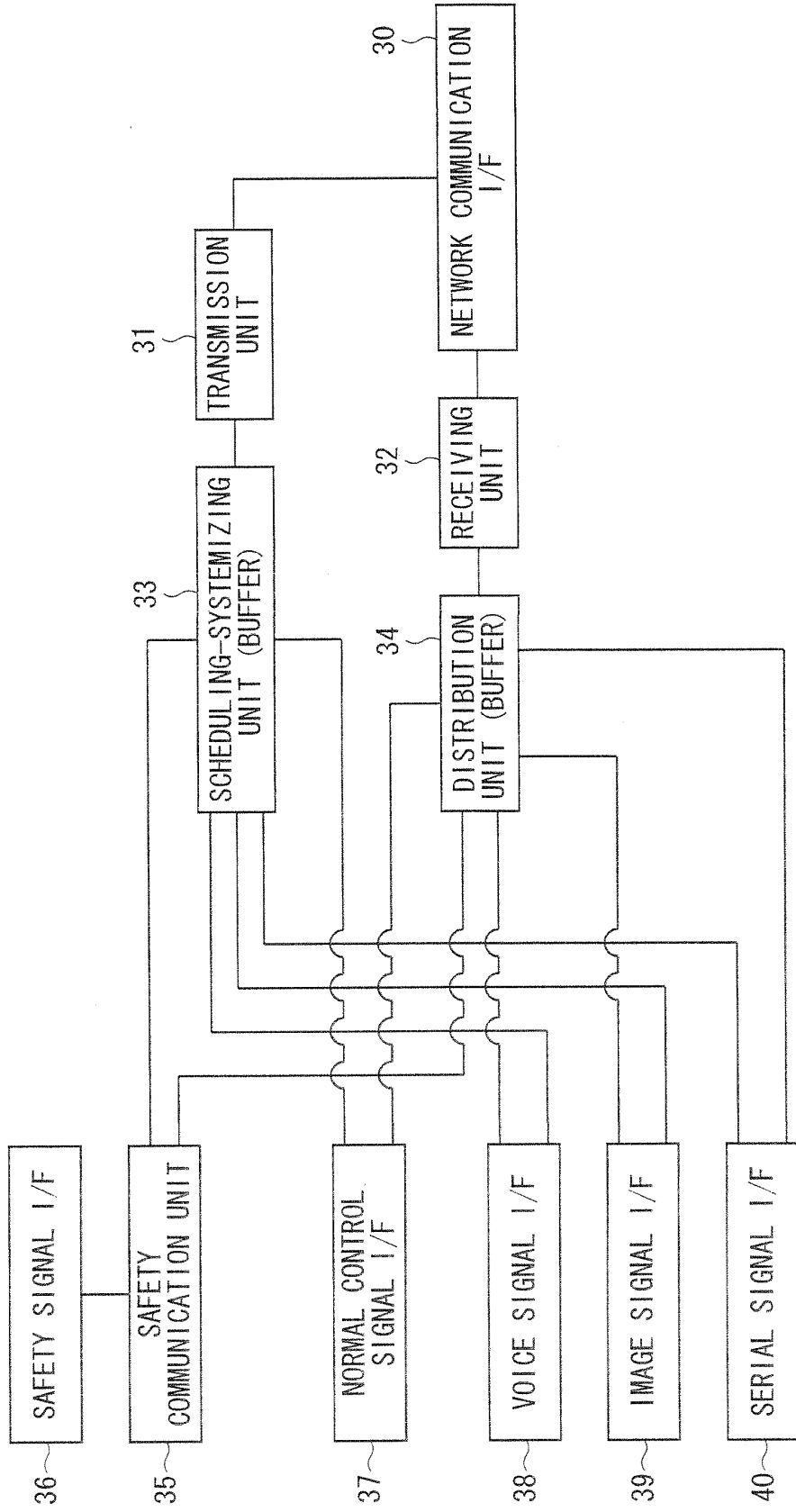

FIG. 3

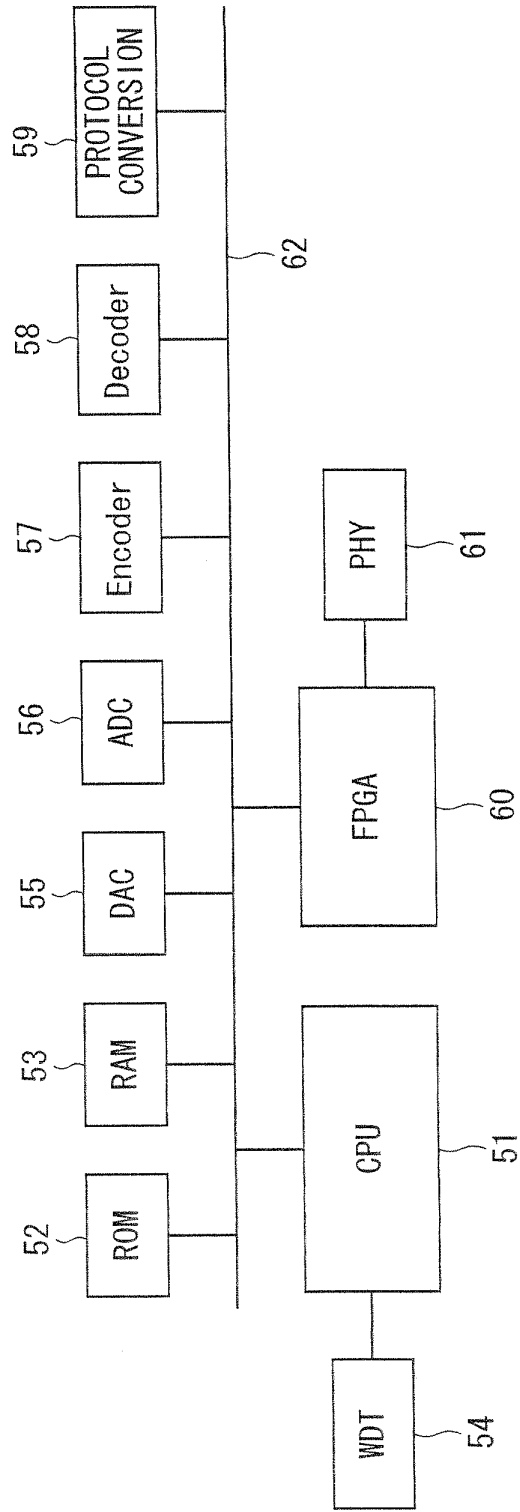

FIG. 4

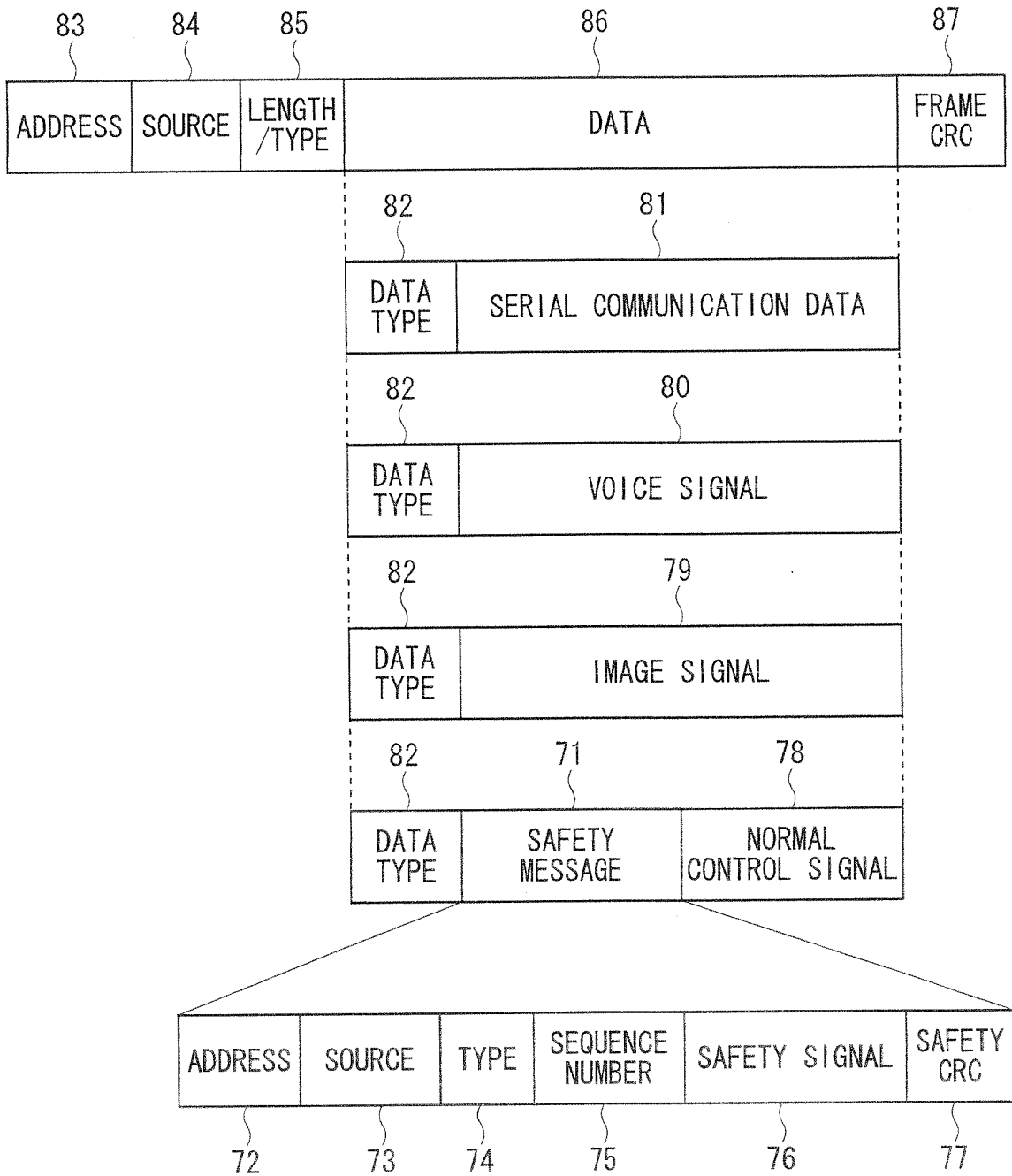

FIG. 5

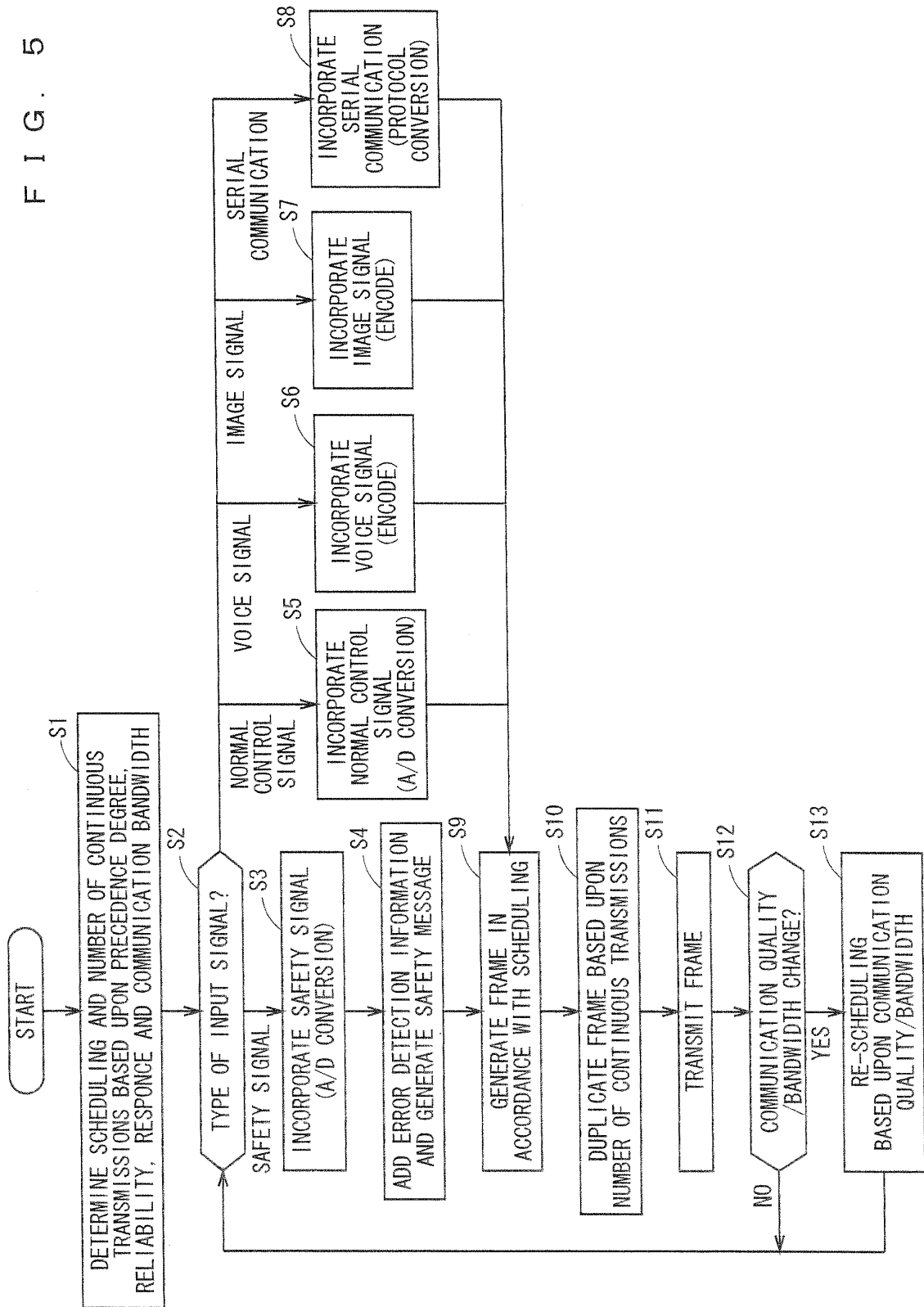
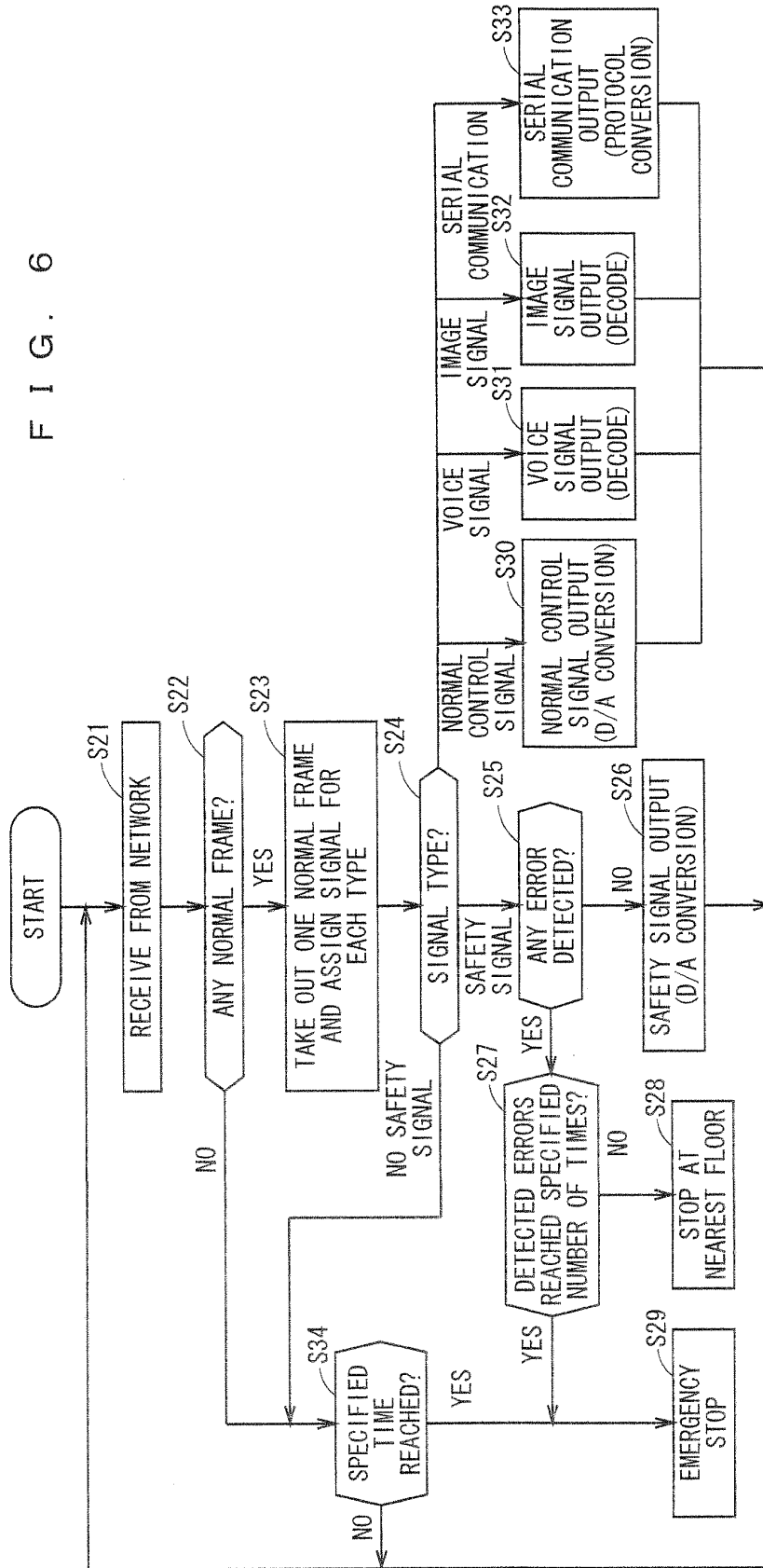
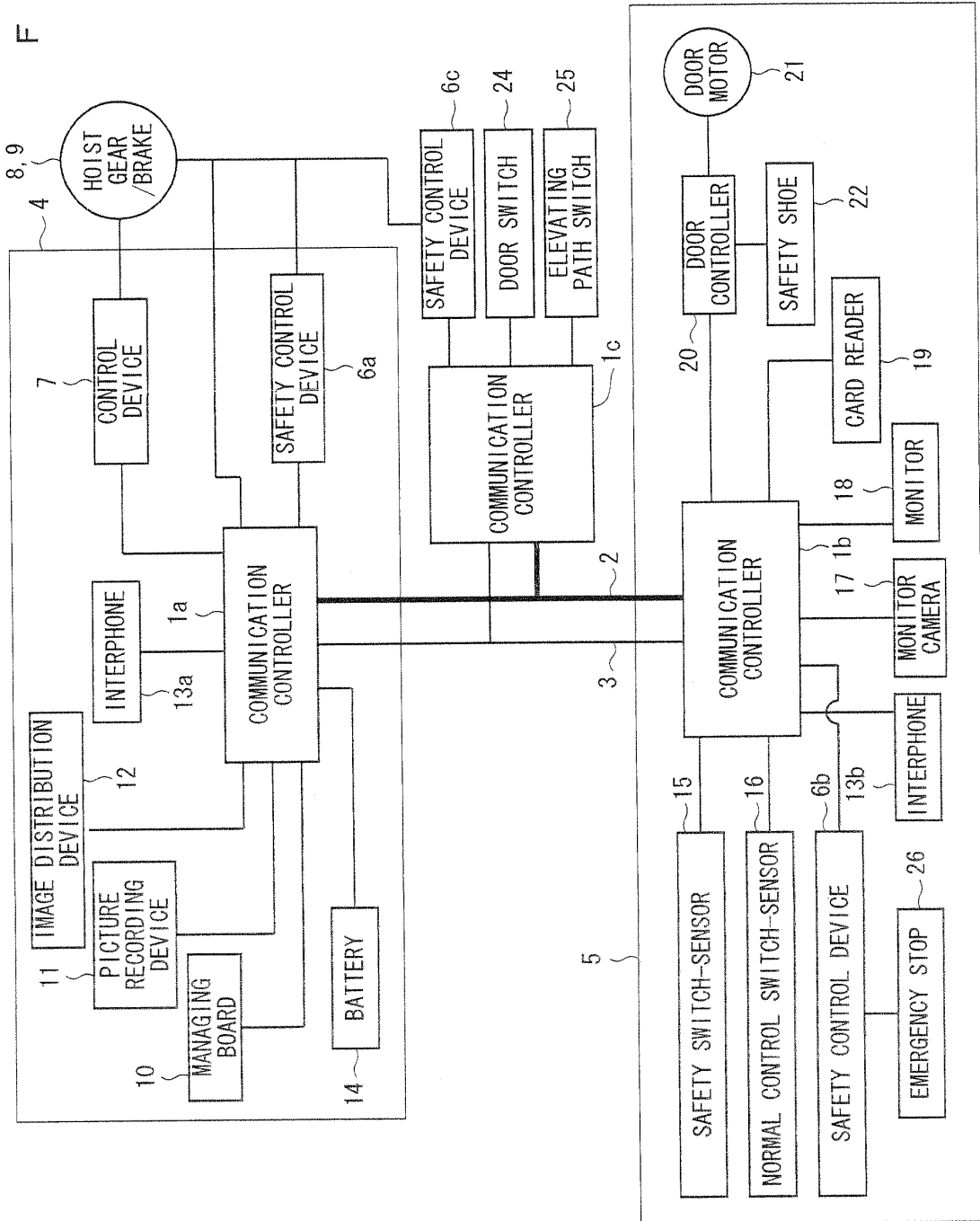

FIG. 6



F I G . 7



REFERENCES CITED IN THE DESCRIPTION

This list of references cited by the applicant is for the reader's convenience only. It does not form part of the European patent document. Even though great care has been taken in compiling the references, errors or omissions cannot be excluded and the EPO disclaims all liability in this regard.

Patent documents cited in the description

- JP 2002538061 PCT [0003] [0005]
- JP 2004048474 A [0004] [0006]
- JP 10167599 A [0007]