



(11) **EP 2 634 325 B1**

(12) **EUROPEAN PATENT SPECIFICATION**

(45) Date of publication and mention of the grant of the patent:
11.09.2019 Bulletin 2019/37

(51) Int Cl.:
E04F 13/08 ^(2006.01) **E04F 13/18** ^(2006.01)
E04F 15/02 ^(2006.01)

(21) Application number: **13157473.3**

(22) Date of filing: **01.03.2013**

(54) **Method for mounting wall panels**

Verfahren zur Montage von Wandpaneelen

Procédé permettant de monter un panneau mural

(84) Designated Contracting States:
AL AT BE BG CH CY CZ DE DK EE ES FI FR GB GR HR HU IE IS IT LI LT LU LV MC MK MT NL NO PL PT RO RS SE SI SK SM TR

(30) Priority: **02.03.2012 GB 201203707**

(43) Date of publication of application:
04.09.2013 Bulletin 2013/36

(60) Divisional application:
19187295.1

(73) Proprietor: **Reco Surfaces Limited**
Freiston
Boston
Lincolnshire PE22 0JZ (GB)

(72) Inventor: **Fleet, Charles**
Boston, Lincolnshire PE22 7BE (GB)

(74) Representative: **Morris, Jonathan Paul**
Urquhart-Dykes & Lord LLP
Altius House
1 North Fourth Street
Milton Keynes MK9 1NE (GB)

(56) References cited:
EP-A1- 1 044 797 DE-A1- 1 659 601
FR-A1- 2 607 529 US-B1- 8 096 093

EP 2 634 325 B1

Note: Within nine months of the publication of the mention of the grant of the European patent in the European Patent Bulletin, any person may give notice to the European Patent Office of opposition to that patent, in accordance with the Implementing Regulations. Notice of opposition shall not be deemed to have been filed until the opposition fee has been paid. (Art. 99(1) European Patent Convention).

Description

[0001] The present invention relates to a method for mounting wall panels. Wall panels may be used in wet areas such as bathrooms, for example around a shower or a bath, as an alternative to tiling. They can be installed more quickly and easily than tiling and require less maintenance.

[0002] Conventional wall panels can comprise flat sheets, for example of a plastics material, or can have a pattern formed therein. Typically a plurality of such sheets is required to cover a section of wall. However a problem with conventional wall panels is that when a pair of panels is located side by side such that their edges abut one another, a distinct joining line is clearly visible. Traditional solutions to hide or disguise this joining line include using a separate joining profile such as a slotted elongate connector member. The connector member successfully hides the joining line however it is much more clearly visible than the joining line itself and therefore it is clear where the separate panels are located.

[0003] Accordingly it is highly desirable to have a wall panel system that provides a substantially seamless appearance to a casual observer.

[0004] When using wall panels in wet areas it is important that any join between adjacent wall panels is watertight. This may be achieved by using a separate joining profile. One such join may comprise an aluminium or plastic extrusion having a generally right angled shape for use in corners or an "H" section for inline joints. Such joining profiles rely on the inherent elasticity/plasticity of the material forming the joining profile (i.e. the aluminium or plastic) to adapt to any variations in the wall panel thickness or the surface of the wall.

[0005] Unlike extrusion, conventional moulding or forming processes create slight variations in the thickness and contours of the wall panel. Further variation may be created when bonding layers together to create a panel and when panels are trimmed to achieve their target thickness. Plastered walls and walls in older buildings may also not be completely true, including portions which are not completely vertical or corners which do not join at exactly 90°. Conventional joining profiles may not adapt well to such variations, resulting in formation of a seal which is not watertight.

[0006] There can also be difficulties in mounting conventional wall panels onto surfaces in a manner that provides a watertight seal. Achieving a watertight seal is very important for wet environments such as bathrooms.

[0007] Typically wall panels are attached to the wall by a suitable adhesive applied to selective areas of the rear of the wall panel which adheres to both the wall panel and wall surface. Often it is necessary to use an adhesive that has good water resistance and gap filling ability in order to properly bond the panels to the wall. Typically the type of adhesives used take a long time to set. It is also difficult to obtain even application of adhesive along a panel edge, particularly when at least one of the panels is joined along a cut edge. When the edges of the panels are not firmly bonded to the wall, the edge of the wall panel may bow outwards slightly, which can give an unsightly finish and prevent a watertight seal from being achieved.

[0008] Known panel systems are disclosed in FR2607529, DE1659601, EP1044797 and US8096093.

[0009] The present invention seeks to mitigate at least one of the problems mentioned above, or at least to provide an alternative method for mounting wall panels and a wall panel system from known methods and systems.

[0010] According to one aspect of the invention there is provided a method for mounting a plurality of wall panels to a surface, such as a bathroom wall, according to claim 1. The method includes providing first and second wall panels, each wall panel having a first major surface having a pattern of channels formed therein, said pattern of channels defining an arrangement of tile-like areas in the first major surface, a second major surface located substantially opposite to the first major surface, and at least one side wall; attaching at least one portion of double sided adhesive tape or film onto the surface; mounting the first wall panel onto the surface by attaching a peripheral portion of its second major surface onto the double sided adhesive tape or film; applying sealant to at least one of the double sided adhesive tape or film and the first wall panel; mounting the second wall panel onto the surface by attaching a peripheral portion of its second major surface onto the double sided adhesive tape or film, the arrangement being such that the side wall of the second wall panel is located adjacent to, and substantially parallel with, the side wall of the first wall panel, and wherein a peripheral portion of the first major surface for the first wall panel and a peripheral portion of the first major surface of the second wall panel are each arranged such that when the first and second wall panels are positioned side by side said peripheral portions define a channel that is substantially similar to at least one of the other channels.

[0011] The invention provides a method for making a watertight joint between two wall panels that is substantially undetectable by a casual observer (i.e. appears to be seamless). There are three important factors for achieving this: 1) the edges of the first and second panels form a channel like structure when mounted side by side, which strongly resembles other channels formed in the panels; 2) the double sided adhesive tape or film tightly binds the edges of the wall panels to the surface of the wall along substantially the full length of the edges, thereby preventing any localised bowing of the panels and ensuring that the edges of the panels are held together in abutting engagement; and 3) any minor gaps between the side walls of the first and second wall panels are substantially sealed by the sealant.

[0012] Using double sided adhesive tape provides instant and substantially even grip along the edge of each wall panel and enables quick and accurate application of sealant along the length of the first wall panel. Thus a fitter does

not have to wait for adhesive to set before mounting the second wall panel.

[0013] Advantageously the or each peripheral portion of the first major surface includes a partial channel formation, which can include at least one longitudinal side wall of a channel. Having a partial channel formation at a peripheral portion of the first major surface enables first and second wall panels to be abutted together so that their partial channel formations form a shape that is similar to at least one of the channels in the major surface. This provides a visual impression to a casual viewer of a substantially continuous surface where the two wall panels join.

[0014] Advantageously the longitudinal side wall of the partial channel formation can include a curved profile. Advantageously the curved profile can include a substantially convex portion. For example, the longitudinal side wall can include a curved bevelled portion. Advantageously the or each partial channel formation can comprise substantially one half of a channel. Having one half of a channel ensures that no special matching of sides is required when mounting wall panels. However it will be appreciated by the skilled person that the partial channels can be formed complementary by having different proportions of a channel. That is, the partial channel formation can be formed using a non-central longitudinal channel axis such that greater, or less than, 50% of the channel is included in the formation. For example, in pairs of complementary formations, one of the formations can have approximately 40% of the channel and the other formation can have approximately 60%, or any other suitable combination such as 45% and 55%, 30% and 70%.

[0015] Each of the channels can include first and second longitudinal side walls. Advantageously at least one of the first and second side walls, and preferably both of the side walls, can include a curved profile. This is particularly evident when viewed in transverse cross-section. Advantageously the curved profile can include a substantially convex portion. This provides the tile-like areas with rounded edges, which helps to provide an easy to clean surface, thereby reducing the build-up of dirt and bacteria on the panel. For example, the longitudinal side walls can include curved bevelled portions.

[0016] Advantageously at least some of the side walls blend into an adjacent tile-like area.

[0017] At least some of the channels can include a base. Advantageously the base can be substantially concave. This is particularly evident when viewed in transverse cross-section.

[0018] Advantageously the width of the or each channel can be greater in the vicinity of a longitudinal channel opening than at the channel base. This helps to visually hide the seams between two panels. In particular, arranging each of the channels in the following manner provides very good results for hiding seams: each channel includes a base, longitudinal side walls, and a longitudinal opening defined by the longitudinal side walls, wherein the longitudinal side walls include substantially convex curved portions, the arrangement being such that the base is narrower than longitudinal opening.

[0019] In preferred embodiments each of said wall panels is substantially square or substantially rectangular in plan.

[0020] Each of said panels can include at least one additional peripheral portion. For example, in embodiments where each panel is substantially square or substantially rectangular in plan, each panel includes four peripheral portions. Each additional peripheral portion can include a partial channel formation, which includes at least one longitudinal side wall of a channel.

[0021] The first major surface can include a second peripheral portion having a second partial channel formation. Increasing the number of longitudinally partial channel formations increases the number of sides on which the panel can form substantially seamless joints. The second partial channel formation can be arranged substantially perpendicular to the first partial channel formation.

[0022] The first major surface can include a third peripheral portion having a third partial channel formation. The third partial channel formation can be arranged substantially parallel to the first partial channel formation.

[0023] The first major surface can include a fourth peripheral portion having a fourth partial channel formation. The fourth partial channel formation is arranged substantially perpendicular to the first partial channel formation.

[0024] Preferably the first and third formations are arranged opposite to one another, and the second and fourth formations are arranged opposite to one another. Advantageously the first and third partial channel formations are arranged substantially complementary to one another. That is, they each comprise opposite sides of a channel. Advantageously the second and fourth partial channel formations are arranged substantially complementary to one another. That is, they each comprise opposite sides of a channel.

[0025] The method can include applying a portion of double sided adhesive tape or film to the surface for each peripheral portion. For example, in embodiments where each panel is substantially square or substantially rectangular in plan, a portion of double sided adhesive tape or film is provided for each of the four edges.

[0026] It will be appreciated by the skilled person that other shapes of wall panel can be used.

[0027] Advantageously the double sided adhesive tape or film is substantially transparent or translucent.

[0028] The method can include forming guide lines onto the surface. The method can include applying the double sided adhesive tape or film to the surface over the guide lines. This is particularly useful for embodiments wherein the tape or film is substantially transparent or translucent, such that lines are still visible when the tape or film overlies the lines.

[0029] Advantageously the second major surface can include a pattern of elongate protrusions arranged oppositely to the pattern of channels, said pattern of elongate protrusions defining an arrangement of recessed areas in the second major surface. The recesses are located opposite to the tile-like areas. This arrangement provides some stiffness to the wall panel and assists with mounting the wall on uneven surfaces since some of the unevenness, particularly localised

EP 2 634 325 B1

unevenness, can be accommodated by the recesses. The depth of the wall panel in the region of the or each partial channel formation is substantially equal to the depth of the wall panel in the region of the channels.

[0030] Advantageously the second major surface can include an elongate protrusion arranged oppositely to the partial channel formation, wherein the peripheral portion of the second major surface is adhered to the double sided tape or film via the elongate protrusion. This provides a very narrow contact area for the double sided tape to grip onto.

[0031] Advantageously the double sided adhesive tape or film can have a sufficiently high-tack to enable it to grip and hold wall panel to the surface, even when the contact area is provided by an elongate protrusion, and is thus very thin, typically having a thickness in the range 1 to 5mm, and preferably around 2mm. Also, because the panels are used in bathrooms where hot water is used, the tape needs to perform well at higher room temperatures and moist environments.

[0032] Advantageously the double sided tape or film has a static shear adhesion at 23°C 1kg/625mm² of at least 4000 minutes, preferably at least 4500 minutes and more preferably still of at least 5000 minutes.

[0033] Advantageously the double sided tape or film has a static shear adhesion at 70°C 0.5kg/625mm² of at least 500 minutes, preferably at least 550 minutes, and more preferably still at least 600 minutes.

[0034] Advantageously the double sided tape or film has a tack AFERA 4015 characteristic of at least 3.0N/25mm, preferably at least 3.5N/25mm and more preferably still at least 4.0N/25mm.

[0035] Advantageously, in an installed state, a portion of double sided adhesive tape or film is applied to the surface for each additional peripheral portion. For example, in embodiments where each panel is substantially square or substantially rectangular in plan, a portion of double sided adhesive tape or film is provided for each of the four peripheral portions. Thus each side of the substantially square or rectangular panel is affixed to the surface.

[0036] At least some of the channels can be arranged substantially vertical when the first and second wall panels are mounted on the mounting surface. At least some of the channels can be arranged substantially horizontal when the first and second wall panels are mounted on the mounting surface.

[0037] The channels can be arranged in a grid pattern in the first major surface. The grid pattern is visible when the first major surface is viewed in plan. This provides a traditional looking tiled arrangement.

[0038] The pattern of channels can include first and second sets of channels. The channels in the first set of channels can be arranged substantially parallel with the first peripheral portion. The channels in the second set of channels can be arranged substantially parallel with an additional peripheral portion. This provides a substantially continuous tiling appearance when two substantially rectangular wall panels are mounted side by side, for a first seam orientation. Preferably the channels in the first set are arranged substantially uniformly spaced apart on the first major surface.

Advantageously the channels in the second set of channels are arranged substantially parallel with the second longitudinally partial channel formation. This provides a substantially continuous tiling appearance when two substantially rectangular wall panels are mounted side by side, for a second seam orientation. The channels in the second set can be arranged substantially uniformly spaced apart on the first major surface. Thus the channels in the second set of channels can be arranged substantially perpendicularly to the channels in the first set of channels.

[0039] Advantageously the wall panel can include sheet material. The wall panel can be made from a single sheet of material. The wall panel is moulded, and is preferably moulded by a vacuum forming process. Other techniques such as hot or cold forming can be used. Since the panel is moulded the channels formed comprise a continuous smooth surface, which is good for hygiene purposes since it is easier to clean and reduces the ability of dirt and bacteria from gripping the surface. This feature is particularly effective when used in conjunction with channels having curved side walls and/or a curved base. For many prior art tile effect boards, the channels are formed by routing. This leaves a rough surface in the groove, which causes dirt to accumulate and makes the board more difficult to clean. The tile edges produced by routing tend to be sharper, and the channel walls flat, which also makes it more difficult to remove dirt.

[0040] Advantageously wall panel is made from, or includes, a water impervious material. Typically the sheet material can include a plastics material such as ABS, acrylic, acrylic-capped ABS (sanitary grade), High Impact Styrene (HPS), Polypropylene (PP), Polyethylene (PE), Polyvinylchloride (PVC), polycarbonate, or any other vacuum formable plastics material. These materials are easy to cut, for example to fit into corners of a room. The thickness of the material used to form the wall panel is less than or equal to 7mm, preferably less than or equal to 6mm, more preferably still less than or equal to 5mm, and most preferably is in the range 1 to 4mm. Because the material is relatively thin it can be mounted on an existing tiled surface without significantly affecting the dimensions of the room thus saving the time, expense and disruption of removing the existing tiles.

[0041] According to another not claimed aspect, there is provided a wall panel system. The wall panel system includes first and second moulded plastics wall panels, each of said first and second wall panels including a first major surface having a pattern of channels formed therein, said pattern of channels defining an arrangement of tile-like areas in the first major surface, a second major surface located substantially opposite to the first major surface, and at least one side wall, wherein a peripheral portion of the first major surface includes a partial channel formation; the arrangement being such that when the side wall of the second wall panel is located adjacent to, and substantially parallel with, the side wall of the first wall panel, said peripheral portions define a channel that is substantially similar to at least one of the other channels. Advantageously the wall panel can be arranged according to any configuration described herein.

[0042] An embodiment of the invention will now be described by way of example only with reference to the accompanying drawings in which:

Figure 1 is a cross-sectional view of a wall panel in accordance with the invention;

Figure 2 is a cross-sectional view of two of the wall panels of Figure 1 laid side by side, in a side abutting arrangement;

Figure 3a shows an enlarged view of the abutting sides of the two wall panels of Figure 2;

Figure 3b shows an enlarged view of the abutting sides of the two wall panels of Figure 2 attached to a wall by a double side tape;

Figure 3c shows an enlarged view of the wall panel of Figure 1 cut longitudinally along a groove to form a new side for engagement with the side of an adjacent wall panel;

Figures 4a and 4b show steps in the process of attaching the wall panels to a wall using a double sided tape and a bead of sealant;

Figure 5 shows a cross-sectional view of the wall panels of Figure 2 two mounted on a wall in side abutting arrangement;

Figure 6a shows diagrammatically a wall marked with a centreline and double sided adhesive tape applied thereto;

Figure 6b shows diagrammatically a wall panel location chart for eight wall panels; and

Figure 6c shows diagrammatically the overall appearance of the eight wall panels, that is, with the joins between panels not easily visible.

[0043] Figure 1 shows a cross-section of a wall panel 1 in accordance with the invention. The wall panel 1 comprises a sheet 3 of a plastics material that has been vacuum formed to provide the sheet with a tile-like 5 formations on a major outer surface 7. Typically the sheet 3 is ABS, acrylic or other similar plastics material, and preferably has a substantially uniform thickness of at least 0.5mm, and preferably is in the range 1mm to 4mm. In the example shown in Figure 1, the sheet 3 has a thickness of 3mm.

[0044] Using moulded plastics panels is very hygienic since it is easy to wipe the surface clean and therefore dirt does not accumulate in the grooves 9.

[0045] Typically the wall panel 1 is substantially rectangular in plan, however other shapes, such as triangles, hexagons, and pentagons are possible.

[0046] The vacuum forming process forms an arrangement of grooves 9 in the sheet 3. The grooves 9 are formed such that they indent the major outer surface 7 and form ribs 11 in a major inner surface 13, with recesses 13b therebetween. The depth of the indentation can be selected according to the thickness of the sheet and to provide the overall desired visual effect wall panel 1. For a sheet 3 having a thickness of around 2mm it is preferred to form grooves 9 having a depth of around 1mm. This provides an overall wall panel depth of around 3mm, measured from the major outer surface 5 to tips of the ribs 11.

[0047] Typically the width of each groove 9 towards its base is around 1mm. The width of each groove 9 towards its opening is around 2mm.

[0048] Typically the arrangement of grooves 9, and hence ribs 11, define substantially rectangular tile-like formations 5. The tile-like formations 5 are preferably arranged in an array. For example, the wall panel 1 in Figure 6a is having a 4 x 4 array of rectangular tile-like formations 5. It will be apparent to the skilled person that the array can have any practicable arrangement. Typically the array will include n columns of tile-like formations 5, where n is in the range 1 to 10, and m rows where m is in the range 1 to 10. However the wall panel 1 may include significantly more tile-like formations 5 than this, for example when providing a mosaic tile-like effect.

[0049] The grooves 9 are arranged to include a first set of grooves 9a, wherein each groove 9a in the set is arranged substantially parallel to one another, and a second set of grooves 9b, wherein each groove 9b is arranged substantially perpendicularly to the first set of grooves 9a. That is, the first and second sets of grooves 9a,9b are arranged in the form of a grid.

[0050] The first set of grooves 9a is arranged substantially parallel to longitudinal side portions 15,17 of the wall panel 1. The second set of grooves 9b is arranged substantially parallel to width side portions 19,21 of the wall panel 1.

[0051] The sides of each groove 9 are defined by first and second convex curvatures 7a,7b that curve downwards

EP 2 634 325 B1

from the tile-like formations 5 towards the base of the groove 9. The base of the groove 9 is defined by a concave curvature 7c, which joins the convex curvatures 7a,7b together. The upper ends of the convex curvatures 7a,7b blend into adjacent tile-like formations 5. The lower ends of the convex curvatures 7a,7b blend into the concave base 7c.

[0052] The maximum width of the grooves 9 in the example shown in Figure 1 is around 4mm. The minimum width is around 1mm. Preferably the width to depth ratio of the grooves 9 is around 1:4. Preferably each convex curvature 7a,7b has a cross-sectional radius of around 1mm.

[0053] Each of the side portions 15,17,19,21 is formed by the vacuum forming process to be shaped similar to half a groove 9, when truncated along a longitudinal axis. Thus each side 15,17,19,21 comprises one convex side wall and part of the concave base. The effect of this is that when two wall panels 1 are placed side by side so that their sides abut, the two complementary sides 15,17,19,21 form a shape that is substantially the same as a groove 9 (shown in cross-section in Figures 3a to 3c and Figure 4b). This provides a visual impression along the joint that is very similar to the grooves 9 formed across the sheets 3. This makes it difficult for the joint to be detected on a casual inspection thus provides the illusion that two adjacent wall panels are part of a continuous wall panel.

[0054] Also, the shape of the grooves 9, in particular having convex side walls helps to hide the location of the joint. This is because the base of the groove 9, where the joint is located, is narrower than the longitudinal opening. This contributes to the optical effect of making it difficult to see joint. The overall appearance provided by the arrangement of the side walls is that of having curved bevelled edges, which blend into the groove base and the planar part of the tiled area, thereby avoiding sharp edges in the upper surface.

[0055] In use, at least one of the wall panels 1 is used to provide a tile effect covering for a surface, typically a bathroom wall 23, for example adjacent a shower or bath. The wall panels 1 are typically arranged to provide a substantially waterproof barrier between a water source and the wall 23. In such arrangements, the wall panels 1 are made from a water impervious material and when at least two panels are joined together an appropriate waterproof seal is applied to prevent water ingress into the joint.

[0056] Typically a wall panel system includes a plurality of wall panels 1, means for attaching the wall panels 1 to the wall, such as double sided adhesive tape 25 and/or an adhesive (not shown), and a settable gap filling sealant 27.

[0057] The double sided adhesive tape 25 is a high-tack, high strength, tape which has been designed to provide a watertight joint, by strongly gripping onto the wall 23 and the panel 1. This is important, since along the edges of the panel 1, where the tape 25 grips the panel 1, only approximately half the width of a rib 11 fully contacts the tape 25. Therefore it is necessary for the tape 25 to have a strong adhesive in order to retain the panel 1 to the wall 23.

[0058] The tape 25 includes a carrier layer that is water resistant, which helps to ensure that the joint is watertight. For example, the carrier layer can comprise a plastics material, and is preferably made from Polyester. The adhesive is a high performance solvent acrylic adhesive suitable for demanding applications, giving very good low and elevated temperatures. It has good resistance to chemicals and UV light.

[0059] Typical characteristics of the tape are as follows:

Tape thickness APERA 4006:	0.07mm
Colour:	Clear
Carrier material:	12 Micron Polyester
180° Peel Adhesion AFERA 4001 10 Min:	10.7 N/25mm
180° Peel adhesion AFERA 4001 24 hrs:	14.2 N/25mm
Dynamic shear adhesion ASTM D-1200 10 mins:	108 N/625mm ²
Static shear adhesion 23°C 1kg/625mm ² :	5500 Minutes
Static shear adhesion 70°C 0.5kg/625mm ² :	700 Minutes
Tack AFERA 4015:	4.60N/25mm
Temperature resistance:	-30°C to 160°C

[0060] The colour of the sealant 27 is selected to substantially match the colour of the wall panels 1.

[0061] Figure 6a illustrates some of the steps for installing the wall panel system. When installing the system, a centreline 29 is marked onto one of the walls 23. The centreline 29 is used as a datum to determine the locations for double sided adhesive tape, according to the wall panel 1 size.

[0062] Strips of double sided adhesive tape 25 are applied to the wall 23 at each site of a joint between two adjacent wall panels 1. Strips of double sided adhesive tape 25 are applied to the wall 23 at each edge of a wall panel to ensure that the edges are firmly bonded to the wall 23. Typically each strip of tape 25 is attached to the wall 23 in a substantially vertical or horizontal orientation.

[0063] Adhesive is applied to the ribs 11 of a first wall panel 1, and the first wall panel 1 is mounted such that at least one of the wall panel side portions 15,17,19,21 is mounted on one of the strips of tape 25. In particular, a partial rib 11

on the major inner surface 13 bonds to the adhesive tape 25.

[0064] A bead of sealant 27 is placed along the tape 25 and/or along the side portion 15,17,19,21 of the first wall panel 1.

[0065] A second wall panel 1 is prepared for mounting on the wall 23 by applying adhesive to the ribs 11. The second wall panel 1 is mounted on the wall 23 such that one of its side portions 15,17,19,21 is mounted on the strip of tape 25.

5 In particular, a partial rib 11 on the major inner surface 13 bonds to the adhesive tape 25. The side portion 15,17,19,21 of the second wall panel 1 abuts the side portion of 15,17,19,21 of the first wall panel 1. This causes the bead of sealant 27 to be forced upwards towards the major outer surfaces 7 of the wall panels 1, thereby filling any gaps between the panels. The sealant 27 is smoothed off to improve the outer appearance.

[0066] When the sealant 27 sets, it prevents the ingress of water into the joint. This together with the tape 25 firmly bonding the side portions 15,17,19,21 to wall, provides a water tight joint.

[0067] The process is repeated for each additional wall panel 1 that is required.

[0068] The overall effect of the wall panel system is to provide wall panels where the joins between panels are substantially undetectable by the casual viewer. This is illustrated by Figures 6a and 6b. Figure 6a shows the plan of where separate wall panels 1 are located, and Figure 6b shows the effect after instalment, where the joins are not easily visible on casual viewing.

[0069] Another advantage of the system is that if the installer needs to cut a wall panel 1 to size, provided that he cuts the panel 1 along one of the channels 9, the overall visual effect is similar to that when placing two preformed panel sides together. The size of wall panels used in any installation can be selected from the most appropriate standard sizes available, or where necessary bespoke panels can be formed.

20 [0070] It will be appreciated by the skilled person that the vacuum forming process can form the sides 15,17,19,21 so that some of the sides have a different proportion of the groove from others. For example some of the sides 15,17,19,21 can have around 60% of the groove when truncated along the longitudinal axis and others can have around 40%. The sides having 40% will be complementary to the sides having 60% such that when complementary sides are abutted together, a whole groove 9 is formed thus giving substantially the same overall impression as when two sides having 50% of a groove are abutted together.

[0071] A wall panel for use in a domestic bathroom has a length 1, where 1 is typically in the range 500mm to 2500mm, and is preferably around 1250mm, and a width w, where w is typically in the range 500mm to 2500mm, and is preferably around 900mm.

[0072] It will be appreciated by the skilled person that the invention is not limited to the described embodiments and includes variations which are within the scope of the appended claims. For example, techniques other than vacuum forming can be used to form the tile-like appearance of the wall panel.

[0073] In the embodiment shown, the tile-like formations 5 have a substantially rectangular shape when viewed in plan. Other shapes, and combinations of shapes are possible. For example, the tile-like formations can have a triangular, pentagonal, hexagonal or other similar shape. Similarly the wall panel shown also has a substantially rectangular shape when viewed in plan. The wall panel can have a triangular, pentagonal, hexagonal or other similar shape.

Claims

40 1. Method for mounting a plurality of wall panels (1) to a surface of a wall, said method including providing first and second wall panels (1), each wall panel (1) having a first major surface (7) having a pattern of channels (9) formed therein, said pattern of channels (9) defining an arrangement of tile-like areas in the first major surface (7), a second major surface (13) located substantially opposite to the first major surface (7), and at least one side wall; **characterized by** the wall panels (1) comprise moulded plastics wall panels, and attaching at least one portion of double sided adhesive tape (25) or film onto the surface; mounting the first wall panel (1) onto the surface by attaching a peripheral portion (15,17,19,21) of its second major surface onto the double sided adhesive tape (25) or film; applying sealant (27) to at least one of the double sided adhesive tape (25) or film and the first wall panel (1); mounting the second wall panel (1) onto the surface by attaching a peripheral portion (15,17,19,21) of its second major surface onto the double sided adhesive tape (25) or film, the arrangement being such that the side wall of the second wall panel (1) is located adjacent to, and substantially parallel with, the side wall of the first wall panel (1), and wherein a peripheral portion (15,17,19,21) of the first major surface for the first wall panel and a peripheral portion (15,17,19,21) of the first major surface of the second wall panel are each arranged such that when the first and second wall panels (1) are positioned side by side said peripheral portions (15,17,19,21) define a channel (9) that is similar to at least one of the other channels (9), the double sided adhesive tape (25) or film tightly binding the peripheral portions of the wall panels to the surface of the wall along substantially the full length of the peripheral portions, thereby preventing any localised bowing of the panels (1) and ensuring that the peripheral portions of the panels are held together in abutting engagement, and any minor gaps between the side walls of the first and second wall panels (1) are substantially sealed by the sealant (27).

EP 2 634 325 B1

2. A method according to claim 1, wherein the or each peripheral portion (15,17,19,21) of the first major surface includes a partial channel formation (9), which includes at least one longitudinal side wall (7a,7b) of a channel.
- 5 3. A method according to claim 1 or 2, wherein each of said channels (9) includes a concave base (7c), longitudinal side walls (7a,7b), and a longitudinal opening defined by the longitudinal side walls (7a,7b), the arrangement is such that the base (7c) is narrower than longitudinal opening, wherein the longitudinal side walls (7a,7b) include substantially convex curved portions, outer ends of the convex curved portions blend into adjacent tile-like areas (5) and lower ends of the convex curvature blend into the convex base (7c).
- 10 4. A method according to any one of the preceding claims, wherein each of said panels (1) includes at least one additional peripheral portion (15,17,19,21), and preferably each of said panels (1) includes three additional peripheral portions (15,17,19,21), including applying a portion of double sided adhesive tape (25) or film to the surface for each additional peripheral portion (15,17,19,21).
- 15 5. A method according to any one of the preceding claims, wherein the thickness of the material used to form each wall panel (1) is less than or equal to 7mm, preferably less than or equal to 6mm and more preferably still less than or equal to 5mm.
- 20 6. A method according to any one of the preceding claims, wherein the first and second wall panels are made from sheet material (3).
7. A method according to any one of the preceding claims, wherein the first and second wall panels (1) are moulded by a vacuum forming process.
- 25 8. A method according to any one of the preceding claims, wherein the second major surface (13) includes a pattern of elongate protrusions (11) arranged oppositely to the pattern of channels (9), said pattern of elongate protrusions (11) defining an arrangement of recessed areas (13b) in the second major surface.
- 30 9. A method according to claim 8, when dependent on claim 2, wherein the second major surface (13) includes an elongate protrusion (11) arranged oppositely to the partial channel, wherein the peripheral portion (15,17,19,21) of the second major surface is adhered to the double sided tape (25) or film via the elongate protrusion (11).
- 35 10. A method according to any one of the preceding claims, wherein the double sided tape (25) or film has a static shear adhesion at 23°C 1kg/625mm² of at least 4000 minutes, preferably at least 4500 minutes and more preferably still of at least 5000 minutes.
- 40 11. A method according to any one of the preceding claims, wherein the double sided tape (25) or film has a static shear adhesion at 70°C 0.5kg/625mm² of at least 500 minutes, preferably at least 550 minutes, and more preferably still at least 600 minutes.
- 45 12. A method according to any one of the preceding claims, wherein the double sided tape (25) or film has a tack AFERA 4015 characteristic of at least 3.0N/25mm, preferably at least 3.5N/25mm and more preferably still at least 4.0N/25mm.

Patentansprüche

1. Verfahren zur Montage einer Vielzahl von Wandpaneelen (1) an einer Oberfläche einer Wand, wobei das Verfahren das Bereitstellen von ersten und zweiten Wandpaneelen (1), wobei jedes Wandpaneel (1) eine erste Hauptoberfläche (7), die ein Muster von darin gebildeten Kanälen (9) aufweist, wobei das Muster von Kanälen (9) eine Anordnung von kachelartigen Bereichen in der ersten Hauptoberfläche (7) definiert, eine im Wesentlichen entgegengesetzt zur ersten Hauptoberfläche (7) gelegene zweite Hauptoberfläche (13) und mindestens eine Seitenwand aufweist; **dadurch gekennzeichnet, dass** die Wandpaneele (1) Wandpaneele aus geformten Kunststoff umfassen, und Anbringen von mindestens einem Abschnitt doppelseitig klebenden Bandes (25) oder klebender Folie an der Oberfläche; Montieren des ersten Wandpaneels (1) an der Oberfläche, indem ein Randabschnitt (15,17,19,21) seiner zweiten Hauptoberfläche an dem doppelseitig klebenden Band (25) oder der doppelseitig klebenden Folie angebracht wird; Auftragen von Dichtungsmaterial (27) an mindestens einem von dem doppelseitig klebenden Band (25) oder der doppelseitig klebenden Folie und dem ersten Wandpaneel (1); Montieren des zweiten Wandpaneels (1)

EP 2 634 325 B1

- auf der Oberfläche, indem ein Randabschnitt (15,17,19,21) seiner zweiten Hauptoberfläche an dem doppelseitig klebenden Band (25) oder der doppelseitig klebenden Folie angebracht wird, umfasst, wobei die Anordnung derart ist, dass sich die Seitenwand des zweiten Wandpaneels (1) angrenzend an die, und im Wesentlichen parallel zu der, Seitenwand des ersten Wandpaneels (1) befindet, und wobei ein Randabschnitt (15,17,19,21) der ersten Hauptoberfläche für das erste Wandpaneel und ein Randabschnitt (15,17,19,21) der ersten Hauptoberfläche des zweiten Wandpaneels jeweils derart angeordnet sind, dass, wenn die ersten und zweiten Wandpaneel (1) Seite an Seite positioniert sind, die Randabschnitte (15,17,19,21) einen Kanal (9) definieren, der ähnlich mindestens einem der anderen Kanäle (9) ist, wobei das doppelseitig klebende Band (25) oder die doppelseitig klebende Folie die Randabschnitte der Wandpaneel dicht an die Oberfläche der Wand entlang im Wesentlichen der vollen Länge der Randabschnitte anbindet, wodurch jegliche lokal begrenzte Wölbung der Paneel (1) verhindert wird und sichergestellt wird, dass die Randabschnitte der Paneel in anliegendem Eingriff zusammengehalten werden, und jegliche kleinere Spalte zwischen den Seitenwänden der ersten und zweiten Wandpaneel (1) im Wesentlichen durch das Dichtmaterial (27) abgedichtet werden.
2. Verfahren nach Anspruch 1, wobei der oder jeder Randabschnitt (15,17,19,21) der ersten Hauptoberfläche eine Teilkanalbildung (9) umfasst, die mindestens eine Längsseitenwand (7a,7b) eines Kanals umfasst.
 3. Verfahren nach Anspruch 1 oder 2, wobei jeder der Kanäle (9) einen konkaven Boden (7c), Längsseitenwände (7a,7b) und eine durch die Längsseitenwände (7a, 7b) definierte Längsöffnung umfasst, wobei die Anordnung derart ist, dass der Boden (7c) enger ist als die Längsöffnung, wobei die Längsseitenwände (7a,7b) im Wesentlichen konvex gekrümmte Abschnitte umfassen, wobei sich äußere Enden der konvex gekrümmten Abschnitte zu nebeneinanderliegenden kachelartigen Bereichen (5) vereinigen und sich untere Enden der konvexen Krümmung zum konvexen Boden (7c) vereinigen.
 4. Verfahren nach einem der vorhergehenden Ansprüche, wobei jedes der Paneel (1) mindestens einen zusätzlichen Randabschnitt (15,17,19,21) umfasst und vorzugsweise jedes der Paneel (1) drei zusätzliche Randabschnitte (15,17,19,21) umfasst, umfassend das Auftragen eines Abschnitts doppelseitig klebenden Bandes (25) oder klebender Folie auf die Oberfläche für jeden zusätzlichen Randabschnitt (15,17,19,21).
 5. Verfahren nach einem der vorhergehenden Ansprüche, wobei die Dicke des zum Bilden von jedem Wandpaneel (1) verwendeten Materials kleiner als oder gleich 7mm, bevorzugt kleiner als oder gleich 6mm und noch bevorzugter kleiner als oder gleich 5mm ist.
 6. Verfahren nach einem der vorhergehenden Ansprüche, wobei die ersten und zweiten Wandpaneel aus Plattenmaterial (3) hergestellt sind.
 7. Verfahren nach einem der vorhergehenden Ansprüche, wobei die ersten und zweiten Wandpaneel (1) durch einen Vakuumformgebungsprozess geformt werden.
 8. Verfahren nach einem der vorhergehenden Ansprüche, wobei die zweite Hauptoberfläche (13) ein Muster von langgestreckten Vorsprüngen (11) umfasst, die entgegengesetzt dem Muster von Kanälen (9) angeordnet sind, wobei das Muster von langgestreckten Vorsprüngen (11) eine Anordnung von zurückgesetzten Bereichen (13b) in der zweiten Hauptoberfläche definiert.
 9. Verfahren nach Anspruch 8, wenn abhängig von Anspruch 2, wobei die zweite Hauptoberfläche (13) einen langgestreckten Vorsprung (11) umfasst, der dem Teilkanal entgegengesetzt angeordnet ist, wobei der Randabschnitt (15,17,19,21) der zweiten Hauptoberfläche an dem doppelseitigen Band (25) oder der doppelseitigen Folie über den langgestreckten Vorsprung (11) geklebt ist.
 10. Verfahren nach einem der vorhergehenden Ansprüche, wobei das doppelseitige Band (25) oder die doppelseitige Folie eine statische Scherhaftung bei 23°C 1kg/625mm² von mindestens 4000 Minuten, bevorzugt mindestens 4500 Minuten und noch bevorzugter von mindestens 5000 Minuten aufweist.
 11. Verfahren nach einem der vorhergehenden Ansprüche, wobei das doppelseitige Band (25) oder die doppelseitige Folie eine statische Scherhaftung bei 70°C 0,5kg/625mm² von mindestens 500 Minuten, bevorzugt mindestens 550 Minuten und noch bevorzugter mindestens 600 Minuten aufweist.
 12. Verfahren nach einem der vorhergehenden Ansprüche, wobei das doppelseitige Band (25) oder die doppelseitige

Folie eine AFERA 4015 Haftcharakteristik von mindestens 3,0N/25mm, bevorzugt mindestens 3,5N/25mm und noch bevorzugter mindestens 4,0N/25mm aufweist.

5 **Revendications**

1. Méthode de montage d'une pluralité de panneaux muraux (1) sur une surface d'un mur, ladite méthode comprenant la mise en place de premier et deuxième panneaux muraux (1), chaque panneau mural (1) possédant une première surface principale (7), incorporant un motif à canaux (9), ledit motif à canaux (9) définissant un agencement de zones de type en tuiles dans la première surface principale (7), une deuxième surface principale (13) située substantiellement face à la première surface principale (7), et au moins une paroi latérale ;
caractérisée en ce que les panneaux muraux (1) comprennent des panneaux muraux moulés en plastique, et fixant au moins une partie de ruban adhésif double face (25) ou de pellicule sur la surface ; le montage du premier panneau mural (1) sur la surface en fixant une partie périphérique (15,17,19,21) de sa deuxième surface principale sur le ruban adhésif double face (25) ou la pellicule ; l'application d'un enduit (27) sur au moins un du ruban adhésif double face (25) ou de la pellicule et le premier panneau mural (1) ; le montage du deuxième panneau mural (1) sur la surface en fixant une partie périphérique (15,17,19,21) de sa deuxième surface principale sur le ruban adhésif double face (25) ou la pellicule, l'agencement étant tel que la paroi latérale du deuxième panneau mural (1) est située dans une position adjacente à la paroi latérale du premier panneau mural (1), et substantiellement parallèle à celui-ci, et une partie périphérique (15,17,19,21) de la première surface principale pour le premier panneau mural et une partie périphérique (15,17,19,21) de la première surface principale du deuxième panneau sont agencées chacune de sorte que lorsque les premier et deuxième panneaux muraux (1) sont positionnés côte à côte, lesdites parties périphériques (15,17,19,21) définissent un canal (9) similaire à au moins un des autres canaux (9), le ruban adhésif double face (25) ou la pellicule liant étroitement les parties périphériques des panneaux latéraux sur la surface du mur, le long substantiellement de la longueur intégrale des parties périphériques, en empêchant ainsi tout cintrage localisé des panneaux (1) et en assurant que les parties périphériques des panneaux sont tenues ensemble par engagement en butée, les écarts mineurs éventuels entre les parois latérales des premier et deuxième panneaux muraux (1) étant substantiellement obturés par l'enduit (27).
2. Méthode selon la revendication 1, la ou chaque partie périphérique (15,17,19,21) de la première surface principale comprenant une formation en canal partielle (9) comprenant au moins une paroi latérale longitudinale (7a, 7b) d'un canal.
3. Méthode selon la revendication 1 ou 2, chacun desdits canaux (9) comprenant une base concave (7c), des parois latérales longitudinales (7a, 7b), et une ouverture longitudinale définie par les parois latérales longitudinales (7a, 7b), l'agencement étant tel que la base (7c) est plus étroite que l'ouverture longitudinale, les parois latérales longitudinales (7a, 7b) comprenant des parties courbes substantiellement convexes, les extrémité extérieures des parties courbes convexes s'insérant dans des zones adjacentes du type tuiles (5) et les extrémité inférieures de la courbure convexe s'insérant dans la base convexe (7c).
4. Méthode selon une quelconque des revendications précédentes, chacun desdits panneaux (1) comprenant au moins une partie périphérique (15,17,19,21) additionnelle, et de préférence chacun desdits panneaux (1) comprenant trois parties périphériques (15,17,19,21) additionnelles, y compris l'application d'une partie de ruban adhésif double face (25) ou de pellicule sur la surface pour chaque partie périphérique (15,17,19,21) additionnelle.
5. Méthode selon une quelconque des revendications précédentes, l'épaisseur du matériau utilisé pour former chaque panneau mural (1) étant inférieure ou égale à 7 mm, de préférence inférieure ou égale à 6 mm, et de façon encore plus préférable inférieure ou égale à 5 mm.
6. Méthode selon une quelconque des revendications précédentes, les premier et deuxième panneaux muraux étant réalisés en matériau en feuille (3).
7. Méthode selon une quelconque des revendications précédentes, les premier et deuxième panneaux muraux (1) étant moulés par un procédé de formage sous vide.
8. Méthode selon une quelconque des revendications précédentes, la deuxième surface principale (13) comprenant un motif de saillies allongées (11) agencé dans un sens opposé au motif de canaux (9), ledit motif de saillies allongées (11) définissant un agencement de zones évidées (13b) dans la deuxième surface principale.

EP 2 634 325 B1

9. Méthode selon la revendication 8, lorsqu'elle est tributaire de la revendication 2, la deuxième surface principale (13) comprenant une saillie allongée (11) agencée dans un sens opposé au canal partiel, la partie périphérique (15,17,19,21) de la deuxième surface principale adhérant au ruban adhésif double face (25) ou à la pellicule par le biais de la saillie allongée (11).

5

10. Méthode selon une quelconque des revendications précédentes, le ruban adhésif double face (25) ou la pellicule ayant une adhérence de cisaillement statique à 23°C 1 kg/625 mm² d'au moins 4 000 minutes, de préférence d'au moins 4 500 minutes, et de façon encore plus préférable d'au moins 5 000 minutes.

10

11. Méthode selon une quelconque des revendications précédentes, le ruban adhésif double face (25) ou la pellicule ayant une adhérence de cisaillement statique à 70°C 0,5 kg/625 mm² d'au moins 500 minutes, de préférence d'au moins 550 minutes, et de façon encore plus préférable d'au moins 600 minutes.

15

12. Méthode selon une quelconque des revendications précédentes, le ruban adhésif double face (25) ou la pellicule ayant une caractéristique d'adhérence AFERA 4015 d'au moins 3,0 N/25 mm, de préférence d'au moins 3,5 N/25 mm, et de façon encore plus préférable d'au moins 4,0 N/25 mm.

20

25

30

35

40

45

50

55

FIG 1

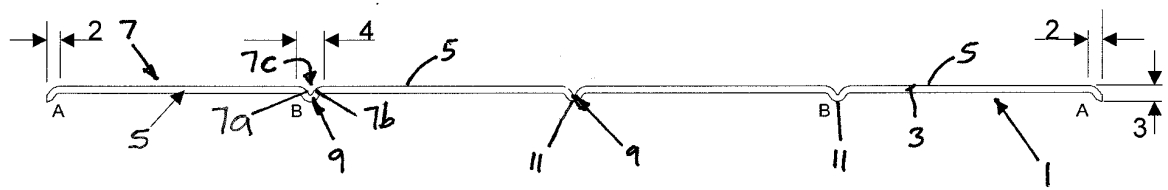

FIG 2

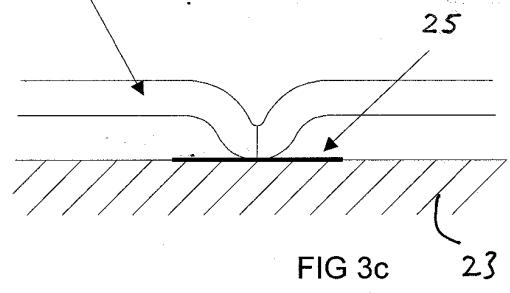
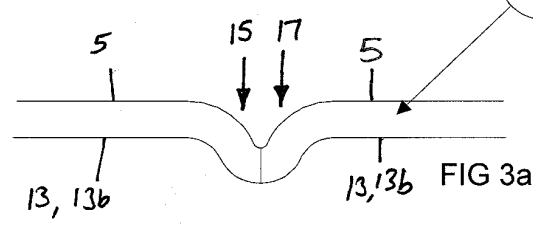
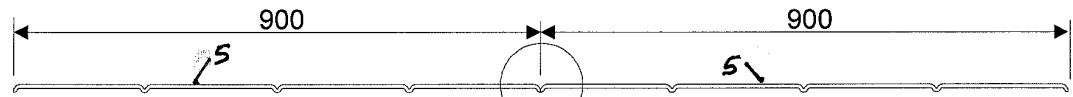

FIG 3b

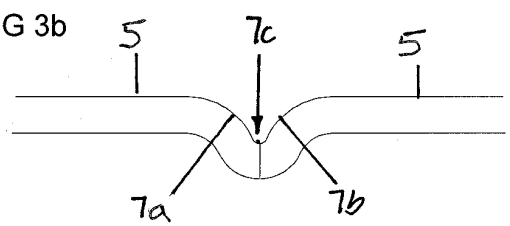

FIG 4a

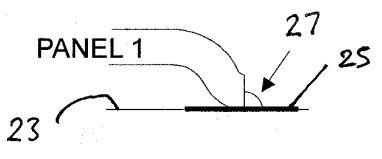

FIG 4b

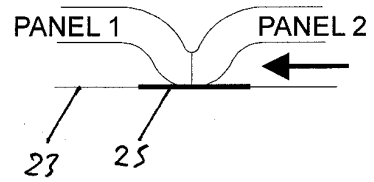
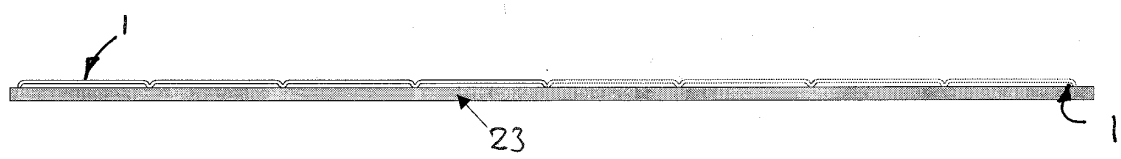

FIG 5



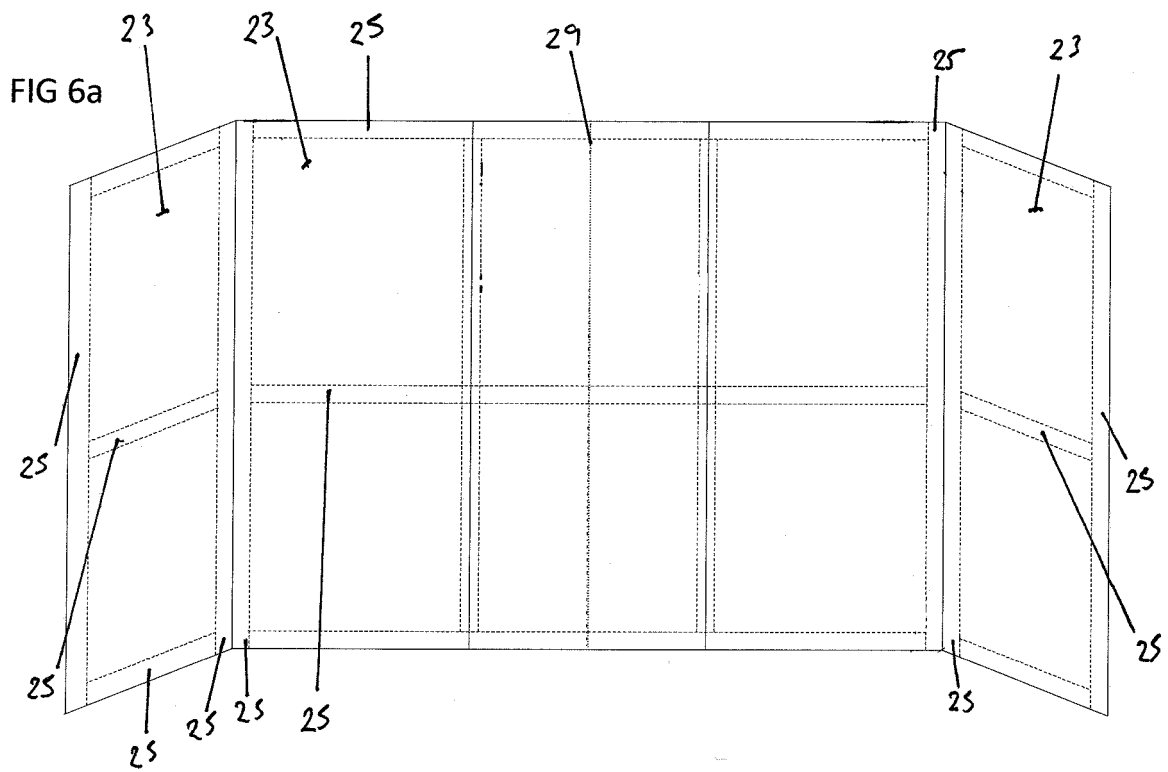

FIG 6 b

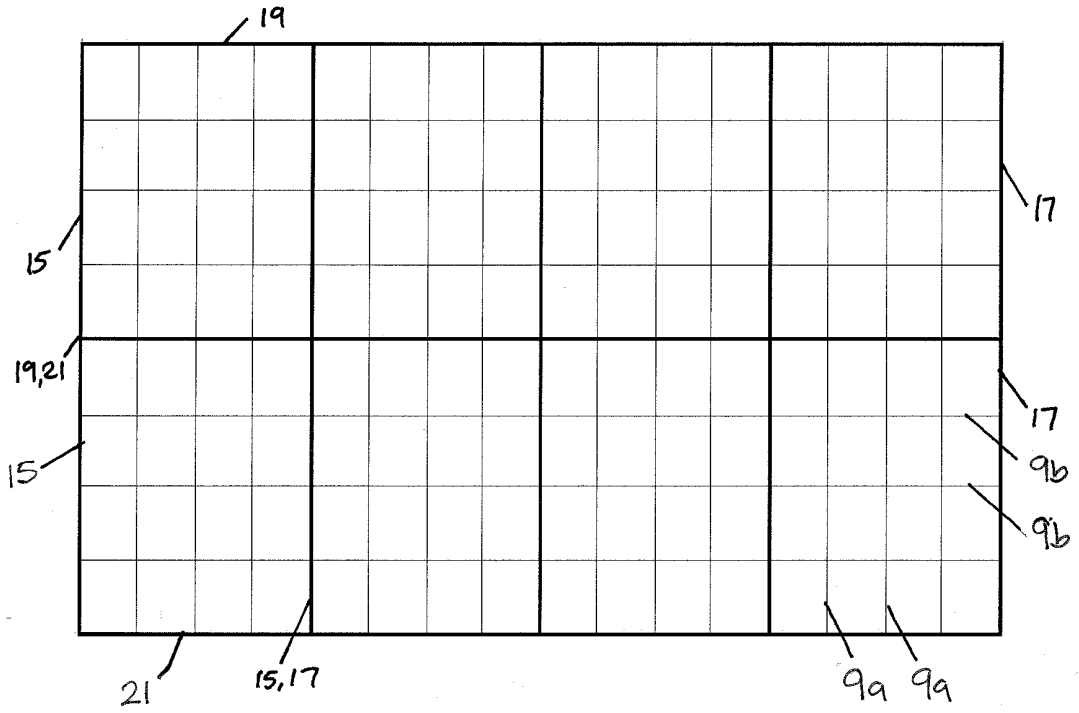
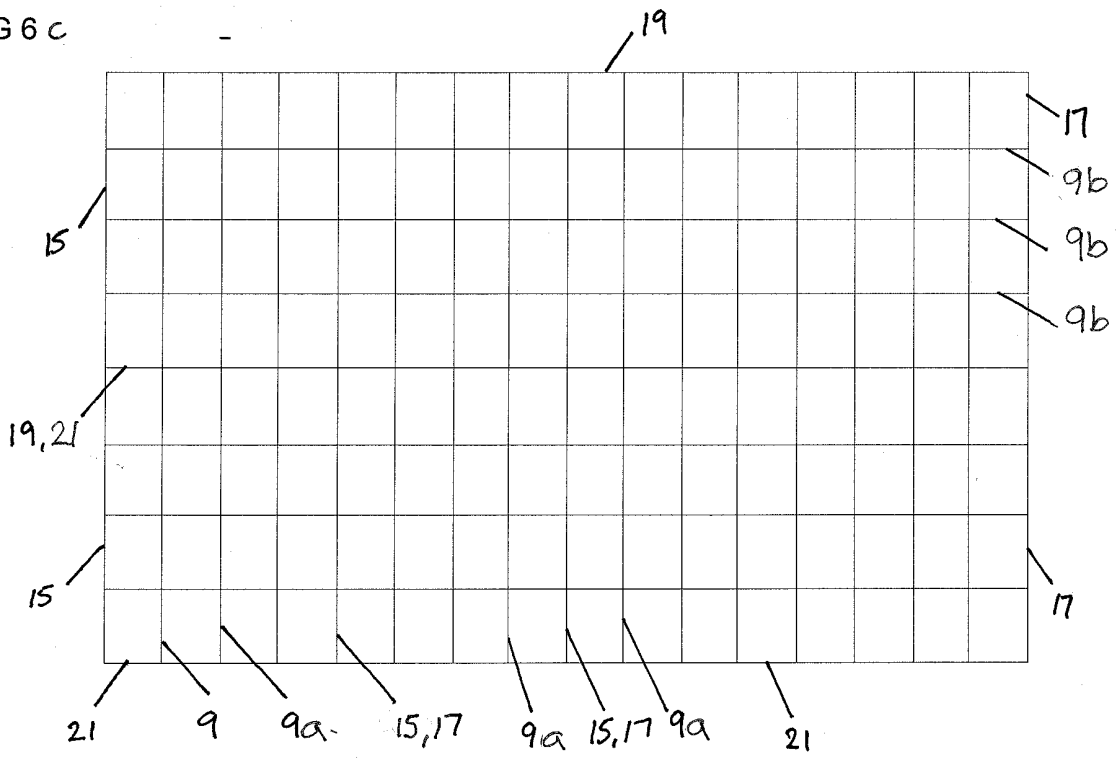

FIG 6 c



REFERENCES CITED IN THE DESCRIPTION

This list of references cited by the applicant is for the reader's convenience only. It does not form part of the European patent document. Even though great care has been taken in compiling the references, errors or omissions cannot be excluded and the EPO disclaims all liability in this regard.

Patent documents cited in the description

- FR 2607529 [0008]
- DE 1659601 [0008]
- EP 1044797 A [0008]
- US 8096093 B [0008]