

(19)



(11)

EP 2 641 493 A1

(12)

EUROPEAN PATENT APPLICATION

(43) Date of publication:
25.09.2013 Bulletin 2013/39

(51) Int Cl.:
A41D 19/00 (2006.01)

(21) Application number: **12001937.7**

(22) Date of filing: **20.03.2012**

(84) Designated Contracting States:
**AL AT BE BG CH CY CZ DE DK EE ES FI FR GB
 GR HR HU IE IS IT LI LT LU LV MC MK MT NL NO
 PL PT RO RS SE SI SK SM TR**
 Designated Extension States:
BA ME

(72) Inventor: **Zaggl, Alexander**
83620 Feldkirchen-Westerham (DE)

(74) Representative: **Prinz & Partner**
Patentanwälte
Rundfunkplatz 2
80335 München (DE)

(71) Applicant: **W.L. Gore & Associates GmbH**
85639 Putzbrunn (DE)

(54) **Breathable dip glove**

(57) A glove (20) comprises a palm panel (10) and a back hand panel (12), the palm panel (10) and the back hand panel (12) being joined by at least one seam (14, 15) to form the glove (20) having a palm side and a back hand side. The glove (20) is further provided at least partially with a coating (22) on one side of the glove (20) which extends partially onto the other side of the glove (20) so as to seal the seam (14, 15) along at least a portion of the length of the seam, wherein the palm panel (10) has a shape which is different from the shape of the back hand panel (12) such that the seam (14, 15) extends partially on that side of the glove (20) provided with the

coating. The invention further relates to a method of forming a breathable glove (20) wherein the glove (20) is being placed on a hand form, the hand form having a hand portion and a wrist portion (61) on which the glove (20) is placed so as to confer to the glove (20) a three-dimensional shape, the wrist portion (61) of the dipping hand having a protruding dipping portion (62) on the palm side or the back hand side, the glove (20) being dipped into a coating bath (60) when being held on the dipping hand such that a coating (22) is deposited on the glove (20) which covers the seam (14, 15) both on the hand portion of the glove (20) and partially on the wrist portion (16).

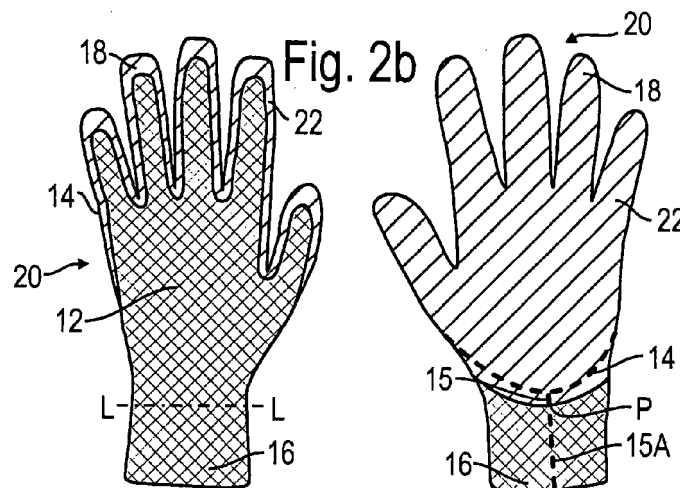

EP 2 641 493 A1

Description

[0001] The invention relates to a glove comprising a palm panel and a back hand panel, the palm panel and the back hand panel being joined by at least one seam to form the glove having a glove palm side and a glove back hand side, the glove being provided at least partially with a coating on one side of the glove which extends partially onto the other side of the glove so as to seal the seam along at least a portion of the length of the seam. The invention further relates to a method of forming a breathable glove, wherein the glove has been placed on a hand form, the hand form having a hand portion and a wrist portion on which the glove is placed so as to confer to the glove a three-dimensional shape.

[0002] Gloves formed from a palm panel and a back hand panel are widely known. An example is shown in Figures 1a - 1d, in which Figure 1a shows a palm panel 10 and a back hand panel 12 for a glove for a left hand. The two panels 10, 12 are joined by a seam 14 (see Figure 1b) which extends along the outer edge of both panels from a starting point S (see Figure 1c) all along the outer edges of a wrist portion 16 of the panels 10, 12, along the fingers 18 and again along wrist portion 16 to an end point E (or in the opposite direction). The edges of wrist portion 16 which are opposite to fingers 18 are not connected so that a hand of a user can be slipped into the glove.

[0003] Instead of using a stitched seam 14, the panels 10, 12 could also be connected with other techniques, for example by gluing them together.

[0004] Palm panel 10 and back hand panel 12 are congruent. In other words, they have the same shape. This results in seam 14 forming the connecting line and simultaneously defining the virtual separation between a palm side of the glove and a back hand side of the glove (in case of congruent panels).

[0005] The two panels 10, 12 are connected to each other by seam 14 to form a glove - 20, which can be provided with a coating 22 on one of its sides, which in the example of Figure 1c is the palm side of the glove 20. Coating 22 can be a dip coating which is applied to glove 20 by placing glove 20 on a hand form and dipping the hand form with the glove into a liquid coating material, possibly repeatedly until a coating with a desired thickness has accumulated on the palm side of the glove.

[0006] If the material used for back hand panel 12 is water-proof and preferably breathable, for example in comprising a water vapor permeable textile or membrane (e.g. ePFTe membrane), humidity emitted by the hand of a person using the glove can be transported to the outside, resulting in a good wearing comfort.

[0007] As can be seen in Figure 1b, coating 22 does not only completely cover palm panel 10 but also seam 14 as it slightly extends onto the back hand side as well. Assuming that the breathable material used for back hand panel 12 is also waterproof, a waterproof glove is formed in this way in which seam 14 is sealed in a wa-

terproof manner by coating 22 to the extent the seam is covered by the coating.

[0008] For a couple of reasons, the wrist portion 16 of the glove is typically not dipped into the coating material.

5 The consequence from this is that each glove has a certain point P as from which onwards seam 14 is no longer sealed by the material which forms coating 22. Looking at Figure 1c, coating 22 can be seen which extends onto the back hand side of glove 20 in the region of the fingers, thereby reliably sealing seam 14 in this region. Towards wrist portion 16 however, coating 22 "retracts" from the back hand side of the glove onto the palm side such that at point P, the boundary of coating 22 "crosses" seam 14, resulting in the portion of the seam extending between the rearward end of wrist portion 16 and point P not being sealed. This seam portion is here designated with reference numeral 14A. It can be seen in Figure 1c that the overall waterproof characteristics of the glove are affected thereby as there is a risk that water penetrates through seam portion 14A if this portion of seam 14 is subjected to water.

[0009] It is of course possible to dip the glove deeper into the liquid coating material so as to "move" point P further towards the rear end of wrist portion 16. The result of this approach is shown in Figure 1d. It can be seen that coating 22 extends farther onto the back hand side and the back hand panel 12 of the glove (in particular the coating extends significantly to the back hand side of fingers 18), resulting in point P being closer to the rear end of wrist portion 16 as compared to the glove shown in Figure 1c. However, the breathing capacity of back hand panel 12 is somewhat reduced as the surface available for transporting humidity is smaller as compared to the glove shown in Figure 1c. Further, a rather large amount of coating material is wasted in particular on the back hand side of fingers 18 of glove 20 as it does not improve the waterproof characteristics of the glove in case the material of back hand panel 12 is already waterproof.

[0010] The object of the invention is to improve a glove formed from a palm panel and a back hand panel regarding its waterproof characteristics without negatively affecting the breathing qualities of the glove.

[0011] In order to solve this object, the invention provides a glove as defined above in which the palm panel has a shape which is different from the shape of the back hand panel such that this seam extends partially on that side of the glove provided with the coating. The invention is based on the idea of abandoning the concept of two identical panels which form the glove and which results in the circumferential seam separating the palm side and the back hand side of the glove. Rather, the panels are formed such that the seam is at least partially arranged on that side of the glove where the coating is provided, resulting in an increased length of the seam being sealed by the coating.

[0012] According to a first embodiment, the seam extends partially on the palm side of the glove, and the

coating is provided on the palm side of the glove extending partially onto the back hand panel. This embodiment allows but not requires using a standard fabric (such as knits, wovens or non-wovens) for the palm panel, the characteristics of the palm panel being mainly determined by the required bonding between the coating and the fabric and by the required comfort in the interior of the glove. The coating ensures that the glove is waterproof on the palm side and can therefore serve two purposes, namely for sealing the palm panel and at the same time acting as a mechanical reinforcement on that side of the glove which is typically subjected to the majority of wear.

[0013] The back hand panel may comprise a waterproof, breathable material. In combination with a coating on the palm side, a glove is achieved which has waterproof, breathable characteristics via the back hand panel and which is waterproof by means of the coating on the palm side (independent from the palm panel material). Nevertheless, manufacturing costs are reduced as no sophisticated material is required for the palm panel.

[0014] According to an alternative embodiment, the seam extends partially on the back hand side of the glove, and the coating is provided on the back hand side of the glove extending partially onto the palm. This embodiment results in a glove in which the back hand side is protected by means of the coating whereas improved tactile characteristics are achieved with the uncoated palm panel.

[0015] In this embodiment the palm panel may comprise a waterproof breathable material. This embodiment results in a good wearing comfort despite the coating on the back hand side of the glove.

[0016] According to a further embodiment, the waterproof, breathable material comprises a membrane, as for example a PTFE or ePTFE membrane or a PU membrane. This material combines good water vapor permeable characteristics with waterproofness and mechanical stability.

[0017] The term "membrane" is to be understood as meaning in particular a film or a coating which forms a barrier at least to air passage through this layer, ideally also with regard to further gases such as for example chemical poisonous gases. The barrier layer is water vapor permeable but air impermeable and/or gas impermeable. The barrier layer is referred to as air impermeable when it has an air transmission rate of less than 25 l/m² and in particular an air transmission rate of less than 5 l/m² (EN ISO 9237, 1995).

[0018] A water impermeable and water vapor permeable flexible membrane suitable for the present invention is described in US- A- 3, 953, 566 which describes a porous expanded polytetrafluoroethylene (PTFE) material. The expanded porous PTFE material has a characteristic microstructure of interconnected nodes and fibrils. The water impermeability of the membrane can be improved when the expanded PTFE material has been coated with a hydrophobic and/or oleophobic coating material.

[0019] The water impermeable and water vapor permeable membrane can also be constructed of a microporous material such as for example polyethylene or polypropylene, microporous polyurethane or polyester, or a hydrophilic monolithic polymer such as polyurethane for example.

[0020] Suitable materials for a waterproof and water vapor permeable barrier layer are in particular polyurethane, polypropylene and polyester, including polyether ester and laminates thereof, as described in US- A- 4, 725, 481 and US- A- 4, 493, 870. Particular preference, however, is given to expanded microporous polytetrafluoroethylene (ePTFE) as described for example in US- A- 3, 953, 566 and US- A- 4, 187.390, and expanded polytetrafluoroethylene provided with hydrophilic impregnants and/or hydrophilic layers; see for example US- A- 4.194.041. A microporous barrier layer has an average pore size between about 0.2 μm and about 0.3 μm.

[0021] Pore size can be measured using a Coulter Porometer (brand name) from Coulter Electronics, Inc., Hialeath, Florida.

[0022] Preferably, the coating is a waterproof coating such that the glove is a waterproof, breathable glove. The waterproof coating can be formed at low costs from natural rubber latex or nitril rubber latex and allows increasing grip and abrasion resistance while fluid is reliably blocked from penetrating into the glove.

[0023] According to one embodiment of the invention, the back hand panel or palm panel comprises at least one wrist flap. The at least one wrist flap is used for forming the wrist portion of the glove and makes it possible to arrange the seam on the side of the glove provided with the coating such that an additional portion of the seam (or even the entire seam) is sealed by the coating material.

[0024] By using a back hand panel or a palm panel which comprises two wrist flaps, the seam at the wrist portion of the glove can be placed at a desired position.

[0025] According to a preferred embodiment, only one seam is provided in the wrist portion. This minimizes the requirement for sealing the seam in the wrist portion.

[0026] As an alternative, two ends of the seam are provided in the wrist portion, between which a wrist extension of the palm panel or the back hand panel extends. This shape of the back hand panel and the palm panel allows using a single, continuous seam for connecting the two panels.

[0027] According to a preferred embodiment, the palm panel and the back hand panel are formed in one piece. This reduces the length of the seam necessary for forming the glove.

[0028] According to an alternative preferred embodiment, the palm panel and the back hand panel are formed as separate pieces. This allows using different materials for the palm panel and the back hand panel, even though the same material for both panels can be used, too.

[0029] It is also possible that at least one of the palm panel and the back hand panel is composed of at least

two pieces, in particular from pieces which are formed from materials having different properties. This allows to even better match the characteristics of the glove with certain requirements, for example increased tactile characteristics in a finger portion of the glove and increased mechanical strength in another portion. It is also possible to use an abrasion resistant laminate on the palm side which can be integrated into the coating provided on the palm side of the glove.

[0030] According to an embodiment of the invention, the back hand panel comprises a palm extension which extends onto the palm side of the glove and fits into a correspondingly formed recess in the palm panel. This shape of the back hand panel allows achieving breathability on the palm side of the glove if the back hand panel is formed from a breathable material.

[0031] In accordance with one embodiment of the invention, an arm portion is provided, the seam being sealed in the arm portion by means of a sealing means. The sealing means can be formed differently from the coating which is used for sealing the seam between the back hand panel and the palm panel in the finger and palm portions of the glove such that a completely waterproof glove is achieved. The sealing means can be in particular a seam sealing tape which allows reliably sealing of the arm portion seam at reasonable expenses. The additional sealing means can of course also be used for gloves which do not have an arm portion but only a (short) cuff portion.

[0032] The coating can be a dip coating such that the coating can be applied with well-known techniques.

[0033] The invention also provides a method of forming a waterproof breathable glove as defined above, in which the wrist portion of a dipping hand has a protruding dipping portion on the palm side, the glove being dipped into a coating bath when being held on the dipping hand such that a coating is deposited on the glove which covers the seam both on the hand portion of the glove and partially on the wrist portion. The particular shape of the dipping hand ensures that an additional portion of the seam which is longer as compared to the prior art, comes into contact with the dipping material, thereby reducing said portion of the seam which is not sealed by the dipping material.

[0034] The invention will now be described with reference to various embodiments which are shown in the enclosed drawings. In the drawings,

Figures 1a to 1d show different aspects of a glove according to the prior art,

Figures 2a and 2b show panels and a glove according to a first embodiment of the invention,

Figures 3a and 3b show panels and a glove according to a second embodiment of the invention,

Figures 4a and 4b show other panels and another glove according to the prior art,

Figures 5a and 5a show panels and a glove according to a third embodiment of the invention,

Figures 6a and 6b show panels and a glove according to a fourth embodiment of the invention,

Figures 7a and 7b show the pieces from which panels for a glove according to a fifth embodiment of the invention are comprised of, and the panels,

Figure 8 shows a glove according to a sixth embodiment of the invention,

Figure 9 shows a glove according to a seventh embodiment of the invention,

Figure 10 schematically shows a particular step for manufacturing a glove according to the invention,

Figures 11a and 11b show the palm side and the back hand side of the glove used in Figure 10, and

Figure 12 schematically shows a cross section along line XII-XII from Figure 10.

[0035] For all embodiments described in the following, a palm panel 10 and a back hand panel 12 are being used which are formed from different materials, except for the embodiment in which palm panel 10 and back hand panel 12 are formed in one piece. In particular, sophisticated materials such as a breathable membrane can be used for uncoated portion of the glove while cheaper fabrics can be used for the portions to which a coating is applied, in particular for the palm panel.

[0036] For certain applications however, identical materials can be advantageous for the back hand panel and the palm panel.

[0037] In one embodiment, the back hand panel 12 is formed from a waterproof, water vapor permeable material, for example a laminate comprising a membrane like a ePTFE membrane. The waterproof water vapor permeable membrane can be attached to at least one textile layer forming a 2 layer laminate. The membrane might also be arranged between at least two textile layers forming a 3 layer laminate. Palm panel 10 can be formed from a material which has good tactile properties and allows application of a coating. For the coating, an elastomeric polymer such as Natural Rubber Latex (NRL), Nitrile Butadiene Rubber (NBR), Polychloroprene (Neoprene) Rubber, plastisoles such as PVC plastisole or a silicone can be used. This material however does not have to be breathable and/or waterproof.

[0038] The coating can also be applied by using injection molding techniques. It is also possible to combine a dip coating with an injection-molded coating.

[0039] After the coating has been applied to the glove, additional elements such as leather strips etc. can be applied to the glove, in particular to coated portions.

[0040] Even though the embodiments described in the following use a coating 22 which is generally applied onto the palm side of the glove, it is to be understood that it is also possible to use a coating which is applied onto the back hand side of the glove while the palm side is essentially without a coating. Then, the waterproof, breathable material will be used for the palm panel while the back hand panel can be made from a simple fabric, apart from those embodiments in which the palm panel and the back hand panel are formed in one piece.

[0041] Further, it is to be understood that the term "seam" is used as a generic designation for the connection between two elements. The seam can be formed as a stitched seam which allows to mechanically connect the edges of the palm panel and the back hand panel to each other. However, other techniques can be used as well, e.g. an adhesive which is applied to one of the panels or to both of them, and which connects the edges such that a glove is formed, or a welded connection. The seam can be waterproof, but does not necessarily have to be waterproof.

[0042] In Figure 2a, a palm panel 10 and a back hand panel 12 are shown, which are being used for manufacturing a glove according to a first embodiment. For the elements known from the discussion of the glove according to the prior art, the same reference numerals are being used, and reference is made to the above comments.

[0043] As can be seen by comparing Figure 2a with Figure 1a, the embodiment of Figure 2a uses two panels 10, 12 which are different from each other as regards their shapes. Palm panel 10 is only in the shape of a hand and does not have any piece which forms the wrist portion of the glove, while back hand panel 12 not only has a wrist piece 24 but also two wrist flaps 26 which are provided on either side of wrist piece 24. Wrist flaps 26 are formed integrally with back hand panel 12.

[0044] For forming the glove, palm panel 10 and back hand panel 12 are joined to each other by using seam 14. Since palm panel 10 does not have a wrist piece, the two wrist flaps 26 are folded around to the palm side forming the wrist portion there. Seam 14 connects both panels along the outer contour of palm panel 10 and back hand panel 12. At the wrist portion the seam 14 moves to the palm side and connects the wrist flaps 26 to the palm panel 10. For closing the glove in the wrist portion 16, an additional wrist seam 15 is used which connects wrist flaps 26 to each other.

[0045] A coating 22 is provided on the palm side of glove 20, which extends slightly onto the back hand side of the glove as well. This ensures that seam 14 connecting palm panel 10 and back hand panel 12 to each other is sealed by the coating material. Coating 22 is here formed from a natural rubber latex or nitril rubber latex so that a waterproof coating is formed. The coating can be applied by dipping the glove with the palm side facing downwardly into reservoir of liquid dipping material. It is also possible to apply the coating by other techniques such as spraying or injection molding or combinations

thereof.

[0046] As a consequence from palm panel 10 and back hand panel 12 not being congruent, seam 14 is only partially arranged as a virtual separation between the palm side and the back hand side of glove 20. Towards the palm side of wrist portion 16, seam 14 is arranged completely on the palm side. Further, seam 15 is arranged completely on the palm side of the glove.

[0047] As can be seen in Figure 2b, point P as from which wrist seam 15 is no longer sealed by coating 22 and forms an uncoated seam portion 15A is arranged more rearwardly (in other words: closer to the wrist opening) as compared to the uncoated seam portion 14A of the prior art glove, allowing the user of the glove to immerse his glove covered hand deeper (up to a level indicated with L) into a liquid before there is a risk of liquid entering into the interior of the glove.

[0048] In Figures 3a and 3b, a glove according to a second embodiment is shown. For the elements known from the first embodiment, the same reference numerals are being used, and reference is made to the above comments.

[0049] With the second embodiment, two panels 10, 12 are used which are different from each other as regards their shapes. Palm panel 10 comprises a wrist portion 24 in a narrow width. Back hand panel 12 has a wrist portion 24 and wrist flaps 26 are being used which are more narrow as with the first embodiment. Therefore, both wrist pieces are different from each other as regards their widths. This results in seam 14 being arranged on the palm side of wrist portion 16 connecting the wrist flaps 26 to the wrist portion of the palm panel 10. As a consequence from the particular arrangement of seam 14 on wrist portion 16, point P as from which onwards seam 14 is sealed by coating 22, is located more rearwardly as compared to the prior art glove. Therefore the length of the uncoated seam portions 14A is less than in the prior art glove.

[0050] In the first and second embodiment, palm panel 10 and back hand panel 12 were formed as separate pieces. It is however also possible to form palm panel 10 and back hand panel 12 in one piece, as can be seen in Figures 4 and 5. Figure 4a shows a palm panel 10 and a back hand panel 12 formed from one piece of material according to the prior art. Folding line PL assigns the border line between both panels 10, 12. As palm panel 10 and back hand panel 12 have the same shape, seam 14 connects both panels along their perimetric edge for forming the glove extends at an "intermediate" level of the glove which separates the palm side from the back hand side, resulting in a long uncovered seam portion 14A after the coating has been applied.

[0051] In Figure 5a, a palm panel 10 and a back hand panel 12 for forming a glove according to a third embodiment are shown. For the elements known from the previous embodiments, the same reference numerals are being used, and reference is made to the above comments.

[0052] In a manner comparable to the first and second embodiments, palm panel 10 and back hand panel 12 have shapes which are different from each other. In the embodiment shown, back hand panel 12 is provided with a wrist flap 26 which results in seam 14 on the wrist portion 26 being arranged onto the palm side of the glove (shown in Figure 5b). Said seam arrangement on the palm side of the wrist portion results in an improved seam sealing. In addition with coating 22 having a portion which protrudes towards wrist portion 16, seam 14 is sealed over more of its length as compared to the prior art design (see location of point P in Figure 5b and Figure 4b). Accordingly, a user can immerse the glove 20 deeper into a liquid before seam portion 14A not sealed by coating 22 is exposed to the liquid.

[0053] In Figure 6, a glove according to a fourth embodiment is shown. For the elements known from the previous embodiments, the same reference numerals are being used, and reference is made to the above comments.

[0054] Regarding the general structure, the glove according to the fourth embodiment is similar to the glove according to the second embodiment shown in Figure 3. The difference is that back hand panel 12 of the fourth embodiment is provided with a palm extension 28 whereas palm panel 10 is provided with a correspondingly formed recess 29 in the back hand panel 12. This results in glove 20 having on the palm side a portion formed from the material of back hand panel 12. By applying a patch which is slightly smaller than palm extension 28, the majority of the surface of palm extension 28 can be kept free from coating 22 while at the same time ensuring that the seam used for connecting palm extension 28 to the edge of recess 29 is completely sealed by the coating material.

[0055] These shapes of the palm panel and the back hand panel result in a breathable portion on the palm side of the coated glove.

[0056] In Figure 7a, the pieces are shown from which palm panel 10 and back hand panel 12 are composed. Palm panel 10 is composed of a finger piece 30 and a hand piece 32, and back hand panel 12 is composed of a finger piece 34 and two hand pieces 36, 38.

[0057] Finger piece 30 and hand piece 32 are joined by a seam 33 (shown in Figure 7b). In view of the coating later applied to the glove, no particular provisions regarding waterproofness are necessary for seam 33.

[0058] Finger piece 34 and hand pieces 36, 38 of the back hand panel are joined along two seams 39 (also shown in Figure 7b). As no coating is to be applied to the back hand side of the glove, sealing means 42 are being used for sealing seams 39, namely e.g. seam sealing tapes 42. These can be applied in a simple manner as straight seams 39 are being used. The advantage of forming panels 10, 12 from a plurality of pieces is that different materials can be used for the pieces such that the material properties can be particularly adapted to the specific requirements.

[0059] In Figure 8, a sixth embodiment is shown. For

the elements known from the previous embodiments, the same reference numerals are being used, and reference is made to the above comments.

[0060] Glove 20 according to the sixth embodiment basically corresponds to the embodiment of Figure 3, but is provided with an arm portion 50 which acts as an extension of wrist portion 16. Accordingly, wrist piece 24 and wrist flaps 26 are formed longer and can be termed arm pieces and arm flaps.

[0061] Seam 14 which extends over the entire arm portion 50 towards wrist portion 16 is sealed by seam sealing tapes 42 so as to arrive at a completely waterproof glove. Here again, straight seams are used so that seam sealing tapes 42 can be applied in a simple manner.

[0062] In Figure 9, an embodiment similar to the embodiment shown in Figure 8 is depicted. In a manner similar to the first embodiment shown in Figure 2, a single seam 14 is being used for connecting palm panel 10 to back hand panel 12. Wrist seam 15 extends not only along wrist portion 16 but also along arm portion 50, and is sealed by means of seam sealing tape 42, resulting in a completely waterproof glove.

[0063] In Figures 10 to 12, a particular way of dipping the glove into the liquid coating material contained in a coating bath 60 is shown. The glove formed from back hand panel 12 and palm panel 10 joined to each other is being placed on a hand form so as to confer to the glove a three-dimensional shape. The hand form has a wrist portion 61 which is provided with a protruding dipping portion 62 (see Figure 12) which maintains wrist seam 15 in a downwardly protruding position such that seam 15 is dipped deeper into coating bath 60 than this is the case with a standard hand form.

[0064] The protruding portion generally has the shape of a rib which extends along the wrist portion and serves for pushing seam 15 deeper into the coating bath than adjacent portions of the glove, resulting in a narrow strip-shaped portion 80 of coating 22 which extends towards the end of wrist portion 16. If no rib was provided, the wrist portion of the glove would be completely covered by the coating.

[0065] As a result, a longer portion of seam 15 is covered by coating material.

Claims

1. Glove (20) comprising a palm panel (10) and a back hand panel (12), the palm panel (10) and the back hand panel (12) being joined by at least one seam (14, 15) to form the glove (20) having a palm side and a back hand side, the glove (20) being provided at least partially with a coating (22) on one side of the glove (20) which extends partially onto the other side of the glove (20) so as to seal the seam (14, 15) along at least a portion of the length of the seam, wherein the palm panel (10) has a shape which is different from the shape of the back hand panel (12)

- such that the seam (14, 15) extends partially on that side of the glove (20) provided with the coating.
2. The glove of claim 1 wherein the seam (14, 15) extends partially on the palm side of the glove (20) and wherein the coating (22) is provided on the palm side of the glove (20) extending partially onto the back hand panel (12). 5
 3. The glove of claim 2 wherein the palm panel (10) and/or the back hand panel (12) comprises a waterproof, breathable material. 10
 4. The glove of claim 3 wherein the palm panel (10) comprises a waterproof, breathable material, in particular PTFE and preferably ePTFE. 15
 5. The glove of any of the preceding claims wherein the seam (14, 15) extends partially on the back hand side of the glove (20) and wherein the coating (22) is provided on the back hand side of the glove (20) extending partially onto the palm panel (10). 20
 6. The glove of any of the preceding claims wherein the coating is a waterproof coating (22) such that the glove (20) is a waterproof, breathable glove. 25
 7. The glove (20) of any of the preceding claims wherein the back hand panel (12) or the palm panel (10) comprises at least one wrist flap (26). 30
 8. The glove (20) of any of the preceding claims wherein at least one seam (14, 15) is provided in the wrist portion (16). 35
 9. The glove (20) of any of the preceding claims wherein the palm panel (10) and the back hand panel (12) are formed of one piece.
 10. The glove (20) of any of claims 1 to 8 wherein the palm panel (10) and the back hand panel (12) are formed as separate pieces. 40
 11. The glove (20) of any of the preceding claims wherein at least one of the palm panel (10) and the back hand panel (12) is composed of at least two pieces (30, 32, 34, 36, 38). 45
 12. The glove (20) of any of the preceding claims wherein the back hand panel (12) comprises a palm extension (28) which extends onto the palm side of the glove (20) and fits into a correspondingly formed recess (29) in the palm panel (10). 50
 13. The glove (20) of any of the preceding claims wherein an arm portion (50) is provided, the seam (14, 15) being sealed at the arm portion (50) by a sealing means (42), preferably a seam sealing tape (42). 55
 14. The glove (20) of any of the preceding claims wherein the coating (22) is a dip coating (60).
 15. The glove (20) of any of the claims 1 to 14 wherein the coating (22) is an injection-molded coating.
 16. A method of forming a breathable glove (20), in particular a glove as defined in any of the preceding claims, wherein the glove (20) is being placed on a hand form, the hand form having a hand portion and a wrist portion (61) on which the glove (20) is placed so as to confer to the glove (20) a three-dimensional shape, the wrist portion (61) of the dipping hand having a protruding dipping portion (62) on the palm side or the back hand side, the glove (20) being dipped into a coating bath (60) when being held on the dipping hand (61) such that a coating (22) is deposited on the glove (20) which covers the seam (14, 15) both on the hand portion of the glove (20) and partially on the wrist portion (16).

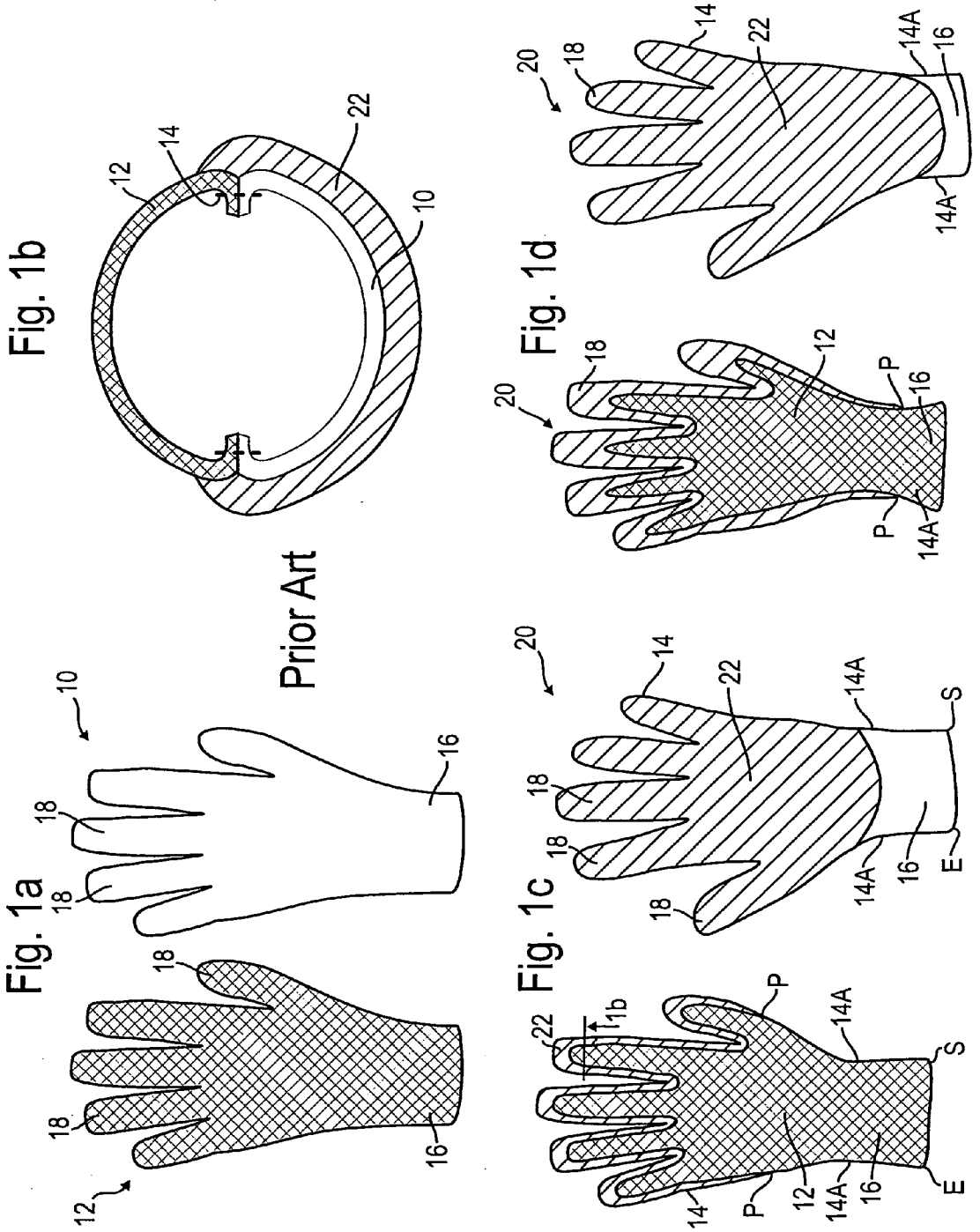

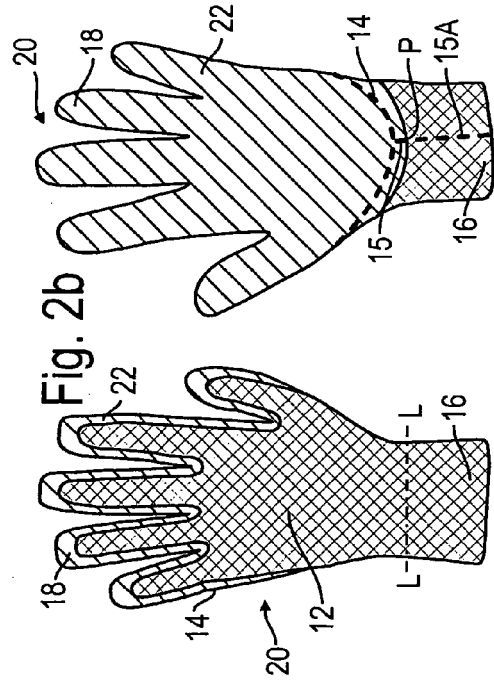
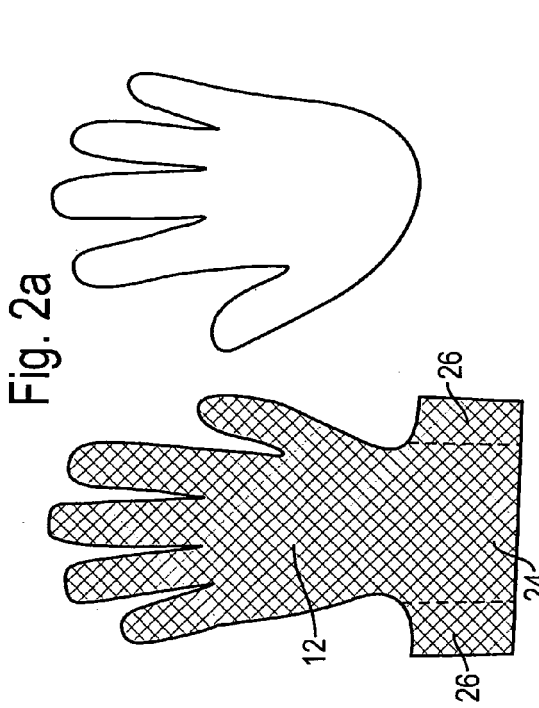
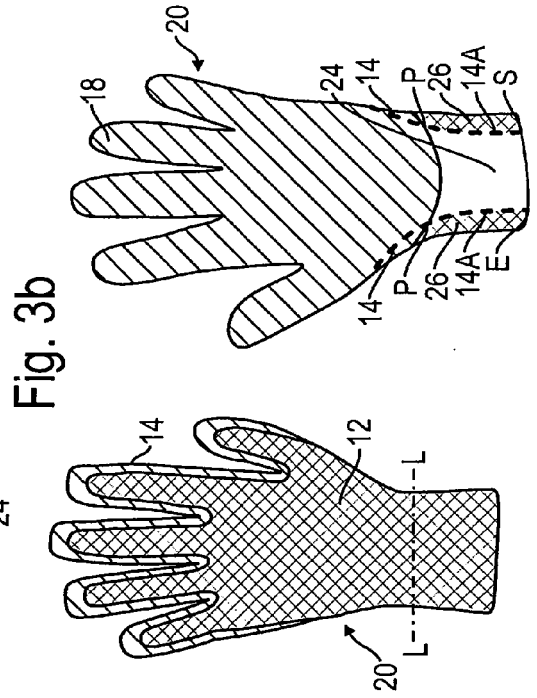
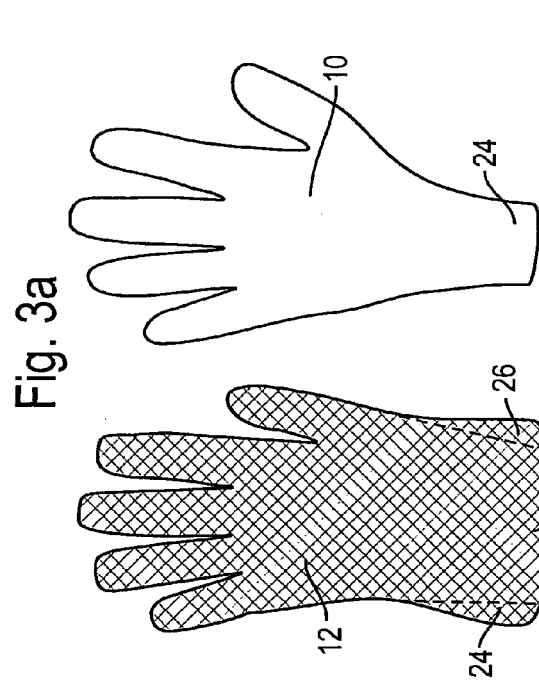

Fig. 5b

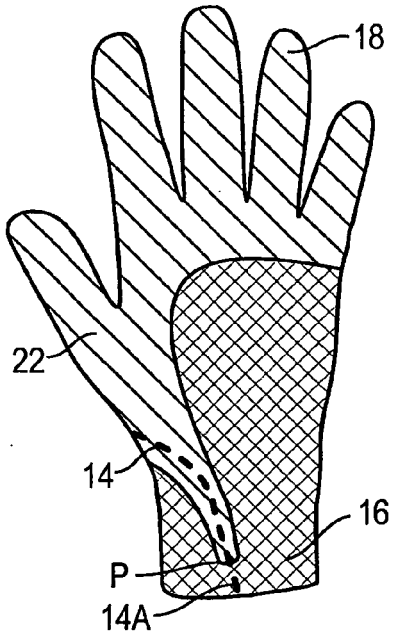

Fig. 5a

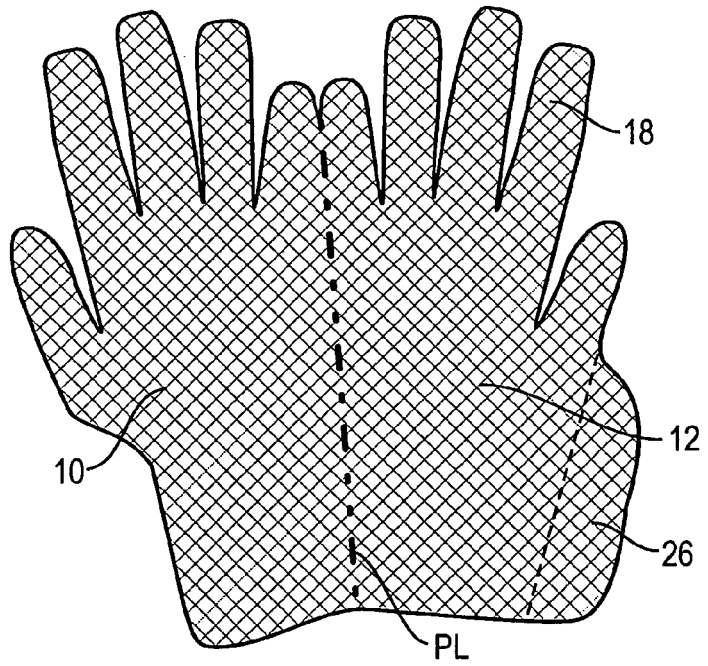

Fig. 4b

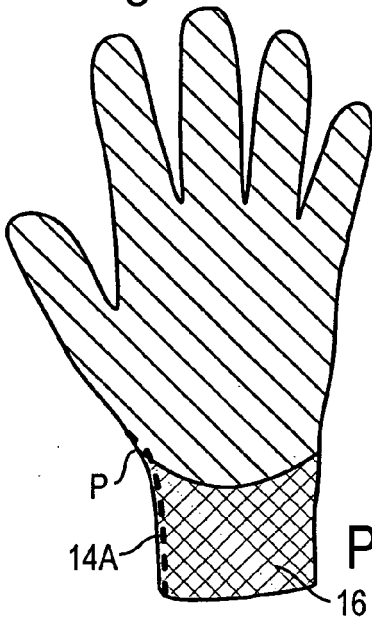
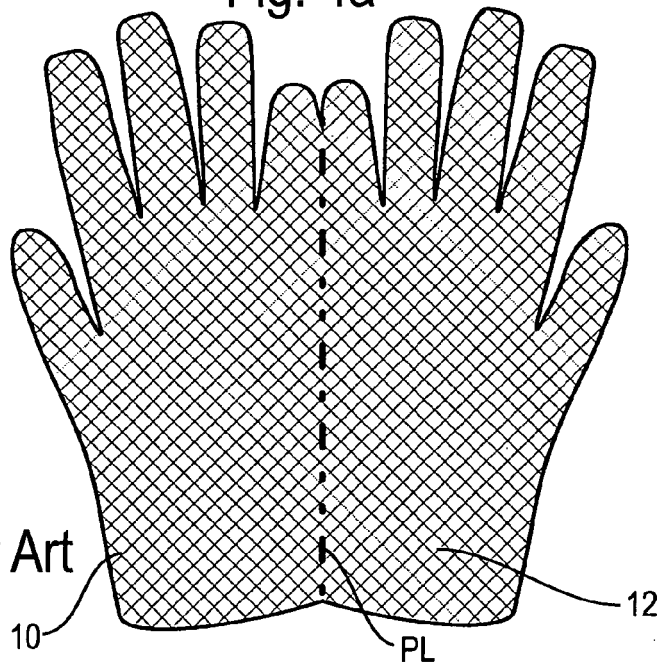

Fig. 4a



Prior Art

Fig. 6a

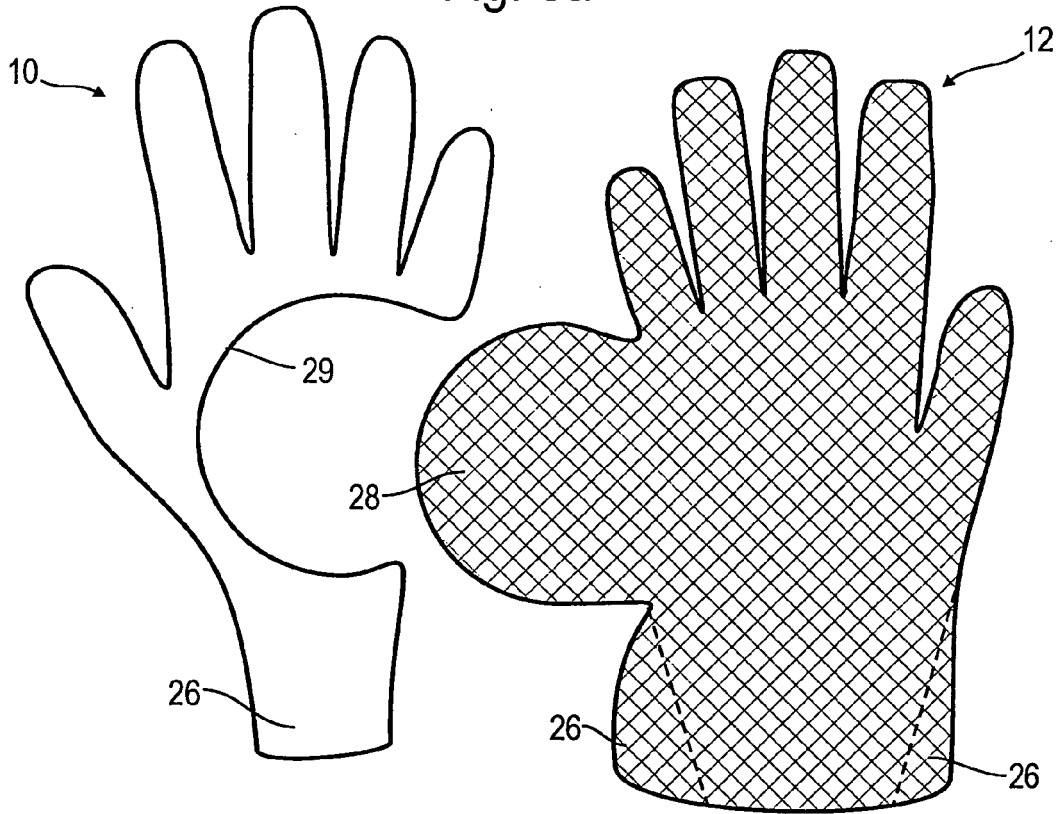

Fig. 6b

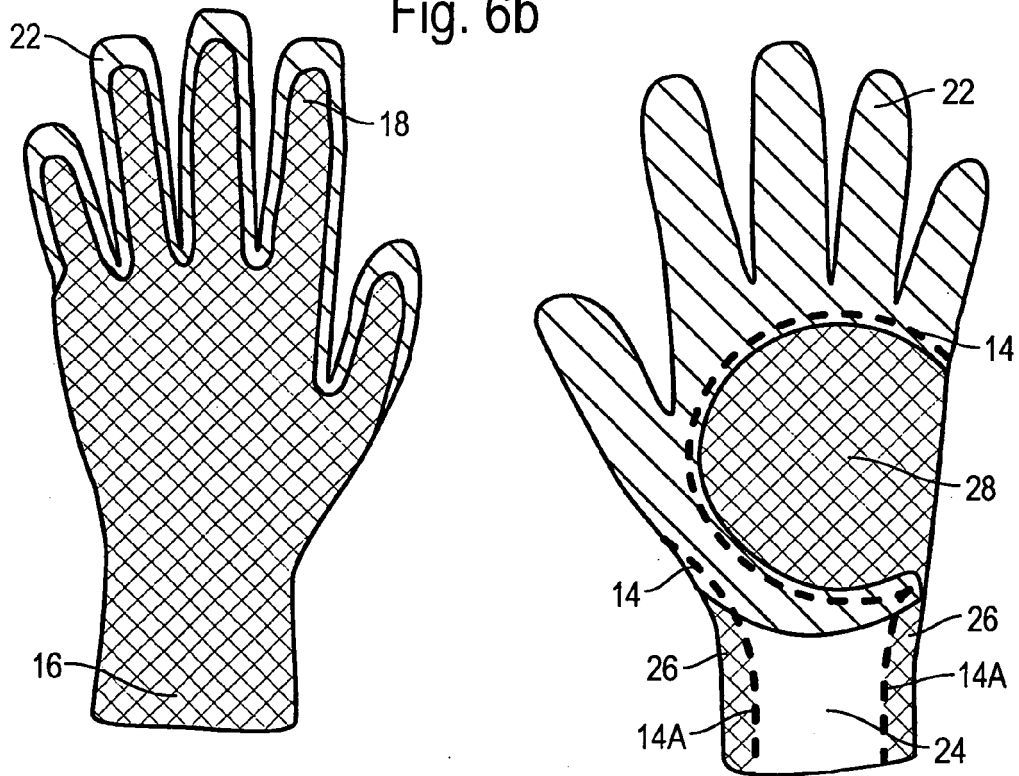

Fig. 7a

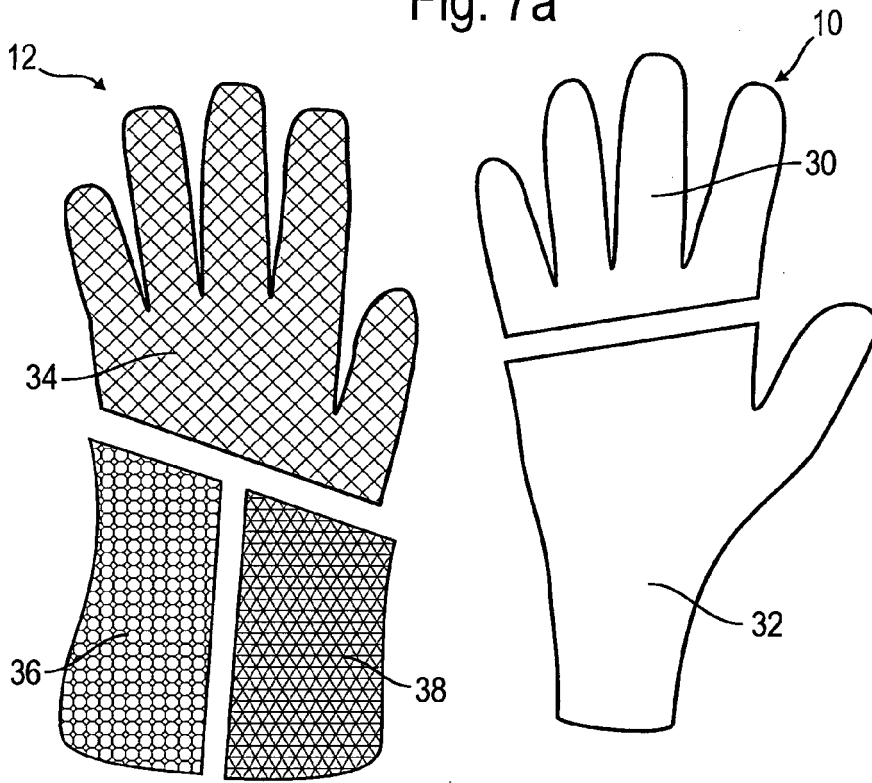

Fig. 7b

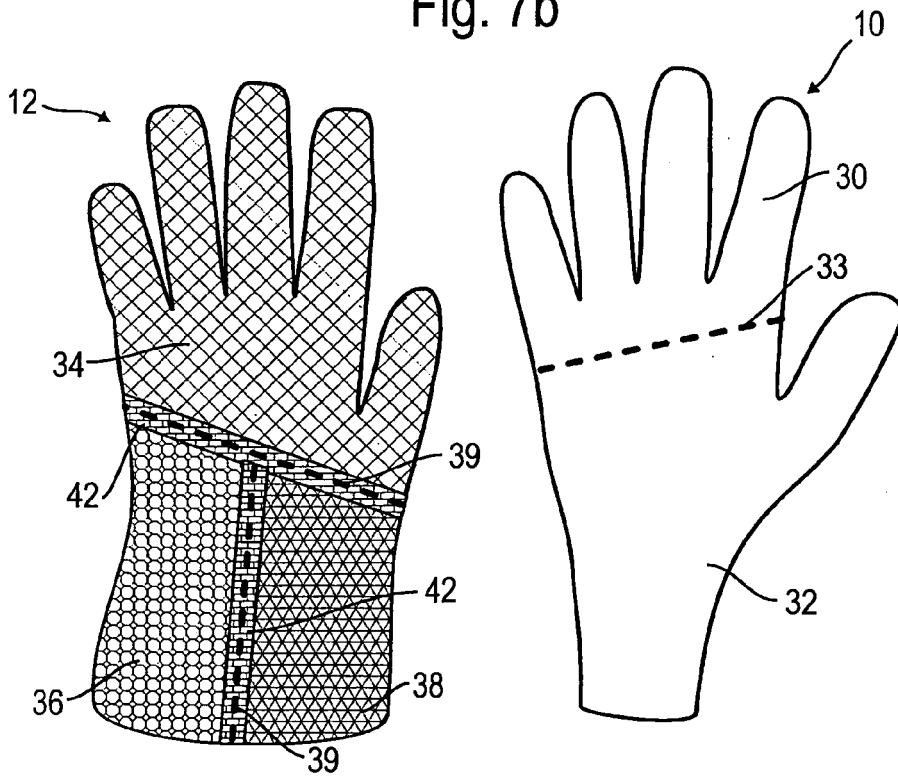

Fig. 8

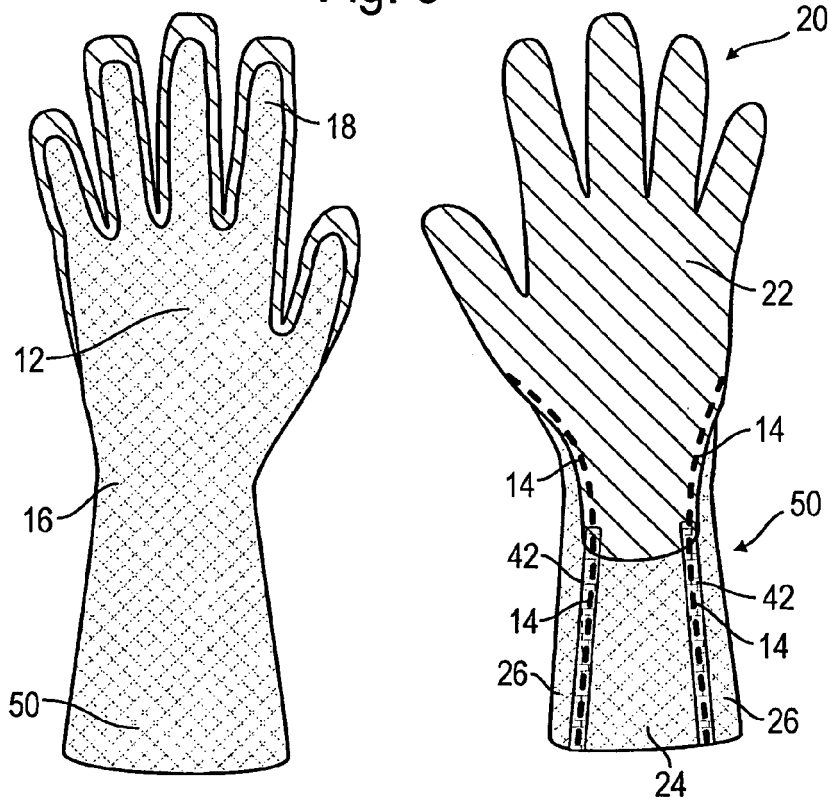

Fig. 9

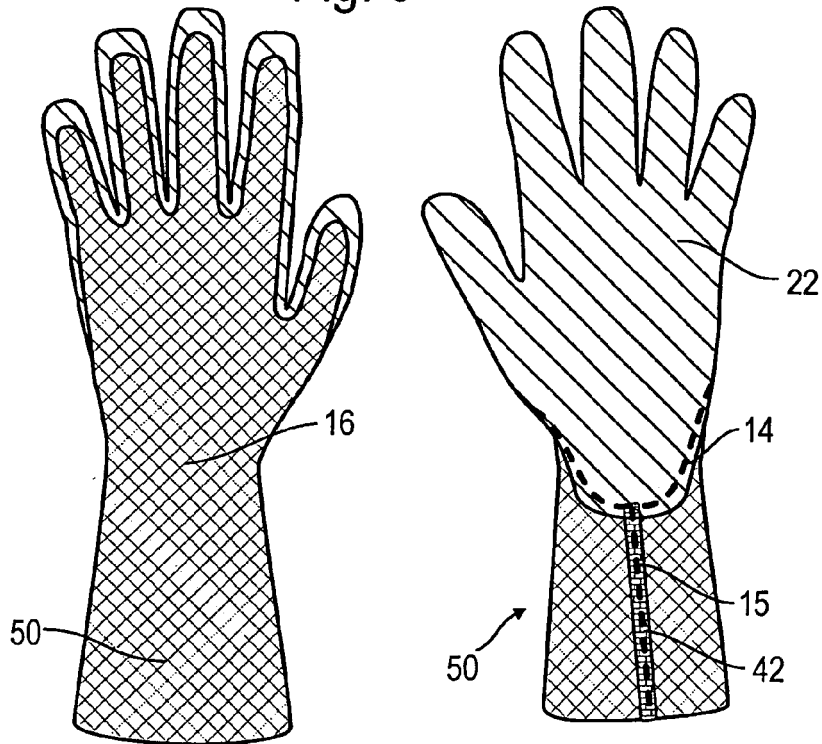

Fig. 10

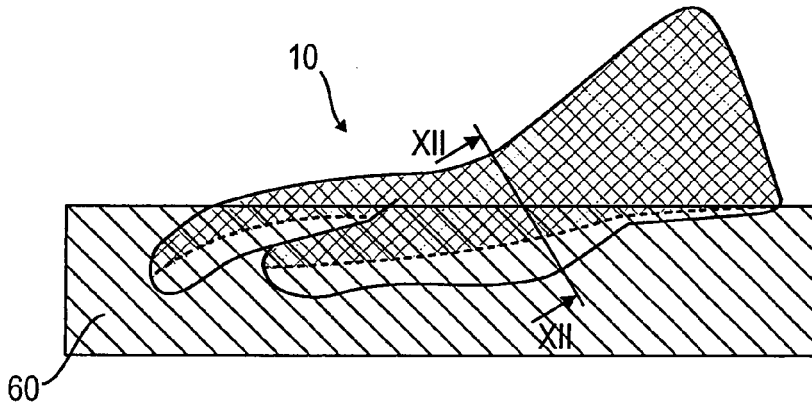

Fig. 11a

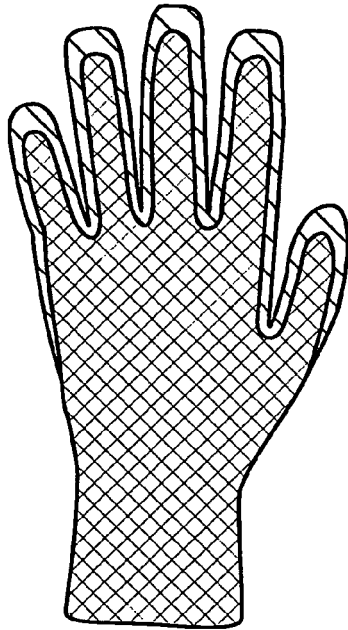

Fig. 11b

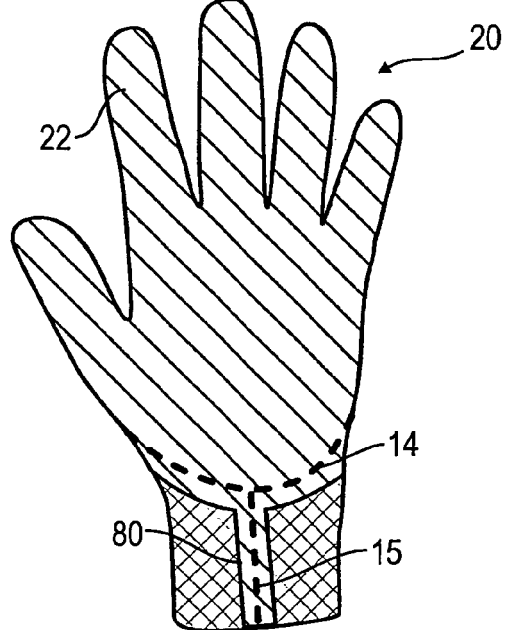
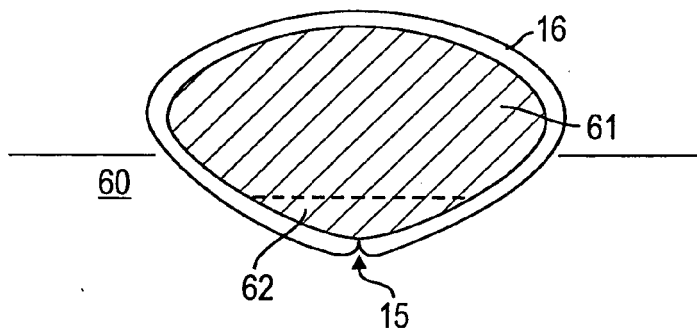

Fig. 12





EUROPEAN SEARCH REPORT

Application Number
EP 12 00 1937

DOCUMENTS CONSIDERED TO BE RELEVANT		
Category	Citation of document with indication, where appropriate, of relevant passages	Relevant to claim
A	WO 2007/040692 A1 (KIMBERLY CLARK CO [US]; YANG KAIYUAN [US]; FISH JEFFREY E [US]; SHAMIS) 12 April 2007 (2007-04-12) * the whole document * -----	1-16
A	US 2010/024095 A1 (GELLIS DAVID [US]) 4 February 2010 (2010-02-04) * abstract; figures * -----	1,16
A	WO 2010/123828 A1 (POLY VERSION INC [US]; GOLDSCHMIEDT PHILIP J [US]) 28 October 2010 (2010-10-28) * abstract; figures * -----	1,16
The present search report has been drawn up for all claims		
Place of search		Date of completion of the search
The Hague		25 September 2012
		Examiner
		Fonseca Fernandez, H
CLASSIFICATION OF THE APPLICATION (IPC) INV. A41D19/00 TECHNICAL FIELDS SEARCHED (IPC) A41D		
CATEGORY OF CITED DOCUMENTS X : particularly relevant if taken alone Y : particularly relevant if combined with another document of the same category A : technological background O : non-written disclosure P : intermediate document T : theory or principle underlying the invention E : earlier patent document, but published on, or after the filing date D : document cited in the application L : document cited for other reasons & : member of the same patent family, corresponding document		

1
EPO FORM 1503 03.82 (P04C01)

ANNEX TO THE EUROPEAN SEARCH REPORT
ON EUROPEAN PATENT APPLICATION NO.

EP 12 00 1937

This annex lists the patent family members relating to the patent documents cited in the above-mentioned European search report. The members are as contained in the European Patent Office EDP file on
The European Patent Office is in no way liable for these particulars which are merely given for the purpose of information.

25-09-2012

Patent document cited in search report	Publication date	Patent family member(s)	Publication date
WO 2007040692 A1	12-04-2007	US 2007083980 A1	19-04-2007
		WO 2007040692 A1	12-04-2007

US 2010024095 A1	04-02-2010	AR 078610 A1	23-11-2011
		AU 2010200342 A1	28-04-2011
		AU 2010307019 A1	03-05-2012
		CA 2713509 A1	12-04-2011
		EP 2308331 A2	13-04-2011
		EP 2488058 A1	22-08-2012
		JP 2011080185 A	21-04-2011
		TW 201138661 A	16-11-2011
		US D645212 S1	13-09-2011
		US D647278 S1	25-10-2011
		US D648919 S1	22-11-2011
		US D650968 S1	27-12-2011
		US 2010024095 A1	04-02-2010
		WO 2011046870 A1	21-04-2011

WO 2010123828 A1	28-10-2010	CA 2759254 A1	28-10-2010
		EP 2421392 A1	29-02-2012
		US 2012079642 A1	05-04-2012
		WO 2010123828 A1	28-10-2010

EPO FORM P0459

For more details about this annex : see Official Journal of the European Patent Office, No. 12/82

REFERENCES CITED IN THE DESCRIPTION

This list of references cited by the applicant is for the reader's convenience only. It does not form part of the European patent document. Even though great care has been taken in compiling the references, errors or omissions cannot be excluded and the EPO disclaims all liability in this regard.

Patent documents cited in the description

- US 3953566 A [0018] [0020]
- US 4725481 A [0020]
- US 4493870 A [0020]
- US 4187390 A [0020]
- US 4194041 A [0020]