



(11) **EP 2 647 301 B1**

(12) **EUROPEAN PATENT SPECIFICATION**

(45) Date of publication and mention of the grant of the patent:
28.08.2019 Bulletin 2019/35

(51) Int Cl.:
A24F 47/00^(2006.01) A24B 15/16^(2006.01)

(21) Application number: **13170148.4**

(22) Date of filing: **27.04.2011**

(54) **Segmented smoking article**

Segmentierter Raucherartikel

Article à fumer segmenté

(84) Designated Contracting States:
AL AT BE BG CH CY CZ DE DK EE ES FI FR GB GR HR HU IE IS IT LI LT LU LV MC MK MT NL NO PL PT RO RS SE SI SK SM TR

(30) Priority: **06.05.2010 US 775278**
06.05.2010 US 775130
19.08.2010 US 859494

(43) Date of publication of application:
09.10.2013 Bulletin 2013/41

(60) Divisional application:
19162492.3 / 3 520 636

(62) Document number(s) of the earlier application(s) in accordance with Art. 76 EPC:
11718610.6 / 2 566 358

(73) Proprietor: **R.J. REYNOLDS TOBACCO COMPANY**
Winston-Salem
North Carolina 27102-1487 (US)

(72) Inventors:
• **Conner, Billy Tyrone**
Clemmons, North Carolina 27102 (US)
• **Sebastian, Andries Don**
Clemmons, North Carolina 27012 (US)
• **Crooks, Evon Llewellyn**
Mocksville, North Carolina 27028 (US)
• **Thomas, Timothy Frederick**
High Point, North Carolina 27265 (US)
• **Stone, James Richard**
Advance, North Carolina 27006 (US)
• **Banerjee, Chandra K.**
Clemmons, North Carolina 27102 (US)
• **Chang, Yi-Ping**
Greensboro, North Carolina 27410 (US)

(74) Representative: **Hoeger, Stellrecht & Partner**
Patentanwälte mbB
Uhlandstrasse 14c
70182 Stuttgart (DE)

(56) References cited:
CN-A- 1 087 497 US-A- 5 247 947
US-A1- 2005 066 985

EP 2 647 301 B1

Note: Within nine months of the publication of the mention of the grant of the European patent in the European Patent Bulletin, any person may give notice to the European Patent Office of opposition to that patent, in accordance with the Implementing Regulations. Notice of opposition shall not be deemed to have been filed until the opposition fee has been paid. (Art. 99(1) European Patent Convention).

Description

TECHNICAL FIELD

5 **[0001]** The present invention relates to products made or derived from tobacco, or that otherwise incorporate tobacco, and are intended for human consumption. The present application relates particularly to components and configurations of segmented-type smoking articles.

BACKGROUND

10 **[0002]** Popular smoking articles, such as cigarettes, have a substantially cylindrical rod-shaped structure and include a charge, roll or column of smokable material, such as shredded tobacco (e.g., in cut filler form), surrounded by a paper wrapper, thereby forming a so-called "smokable rod", "tobacco rod" or "cigarette rod." Normally, a cigarette has a cylindrical filter element aligned in an end-to-end relationship with the tobacco rod. Preferably, a filter element comprises plasticized cellulose acetate tow circumscribed by a paper material known as "plug wrap." Preferably, the filter element is attached to one end of the tobacco rod using a circumscribing wrapping material known as "tipping paper." It also has become desirable to perforate the tipping material and plug wrap, in order to provide dilution of drawn mainstream smoke with ambient air. Descriptions of cigarettes and the various components thereof are set forth in Tobacco Production, Chemistry and Technology, Davis et al. (Eds.) (1999) and U.S. Pat. No. 7,503,330 to Borschke et al. A cigarette is employed by a smoker by lighting one end thereof and burning the tobacco rod. The smoker then receives mainstream smoke into his/her mouth by drawing on the opposite end (e.g., the filter end) of the cigarette.

20 **[0003]** Certain types of cigarettes that employ carbonaceous fuel elements have been commercially marketed under the brand names "Premier" and "Eclipse" by R. J. Reynolds Tobacco Company. See, for example, those types of cigarettes described in Chemical and Biological Studies on New Cigarette Prototypes that Heat Instead of Burn Tobacco, R. J. Reynolds Tobacco Company Monograph (1988) and Inhalation Toxicology, 12:5, p. 1-58 (2000). More recently, a cigarette has been marketed in Japan by Japan Tobacco Inc. under the brand name "Steam Hot One." It has also been suggested that the carbonaceous fuel elements of segmented types of cigarettes may incorporate ultrafine particles of metals and metal oxides. See, for example, U.S. Pat. App. Pub. No. 2005/0274390 to Banerjee et al.

25 **[0004]** Yet other types of smoking articles, such as those types of smoking articles that generate flavored vapors by subjecting tobacco or processed tobaccos to heat produced from chemical or electrical heat sources are described in U.S. Pat. Nos. 5,285,798 to Banerjee et al. and 7,290,549 to Banerjee et al., and U.S. Pat. App. Pub. No. 2008/0092912 to Robinson et al. One type of smoking article that has employed electrical energy to produce heat has been commercially marketed by Philip Morris Inc. under the brand name "Accord."

30 **[0005]** Smoking articles that employ sources of heat other than tobacco cut filler to produce tobacco-flavored vapors or tobacco-flavored visible aerosols have not received widespread commercial success. However, it would be highly desirable to provide smoking articles that demonstrate the ability to provide to a smoker many of the benefits and advantages of conventional cigarette smoking, without delivering considerable quantities of incomplete combustion and pyrolysis products.

SUMMARY

35 **[0006]** Embodiments of the present invention relate to smoking articles, and in particular, to rod-shaped smoking articles, such as cigarettes. A smoking article includes a lighting end (i.e., an upstream end) and a mouth end (i.e., a downstream end). The smoking article also includes an aerosol-generation system that includes (i) a heat generation segment, and (ii) an aerosol-generating region or segment located downstream from the heat generation segment. The smoking article may be configured in a variety of ways, including various insulative configurations related to the heat generation segment that may include one or more of glass or non-glass fiber materials that may or may not be woven and/or stitch-bonded, foamed monolithic material selected from metal, ceramic, and ceramic-metal composite (e.g., cermet), or other materials, which materials may also be incorporated in a buffer region between the heat generation and aerosol-generation segments.

40 **[0007]** Further features and advantages of the present invention are set forth in more detail in the following description.

BRIEF DESCRIPTION OF THE DRAWINGS

45 **[0008]** Embodiments may better be understood with reference to the following drawings, which are illustrative only and are not limiting.

FIG. 1 and FIG. 2 provide longitudinal cross-sectional views of representative smoking articles;

FIG. 3 shows a representative fuel element not covered by the claims;
 FIGS. 4A-4G show representative fuel element and insulation embodiments not covered by the claims;
 FIG. 5 shows another representative smoking article embodiment including a substrate that includes multiple layers
 stitch-bonded together covered by the claims;
 FIGS. 6A-6D show representative monolithic substrate element embodiments not covered by the claims; and
 FIGS. 7-9 each show a longitudinal cross-sectional view of a representative smoking article including a monolithic
 substrate not covered by the claims.

DETAILED DESCRIPTION OF THE PREFERRED EMBODIMENTS

[0009] Aspects and embodiments of the present invention relating to various smoking articles, the arrangement of various components thereof, and the manner that those smoking articles incorporate overwrap components, are illustrated with reference to FIGS. 1 and 2. Like components are given like numeric designations throughout the figures. For the various figures, the thicknesses of the various wrapping materials and overwraps of the various smoking articles and smoking article components are exaggerated. Most preferably, wrapping materials and overwrap components are tightly wrapped around the smoking articles and smoking article components to provide a tight fit, and provide an aesthetically pleasing appearance. Exemplary smoking article construction may include features such as fibrous filter elements, foamed ceramic monoliths formed as insulators or fuel elements, and other features disclosed in U.S. Pat. App. Ser. No. 12/546,107 to Sebastian, et al., filed August 24, 2009.

[0010] Referring to FIG. 1, a representative smoking article 10 in the form of a cigarette is shown. The smoking article 10 has a rod-like shape, and includes a lighting end 14 and a mouth end 18.

[0011] At the lighting end 14 is positioned a longitudinally extending, generally cylindrical smokable lighting end segment 22, incorporating smokable material 26. A representative smokable material 26 can be a plant-derived material (e.g., tobacco material in cut filler form). An exemplary cylindrical smokable lighting end segment 22 includes a charge or roll of the smokable material 26 (e.g., tobacco cut filler) wrapped or disposed within, and circumscribed by, a paper wrapping material 30. As such, the longitudinally extending outer surface of that cylindrical smokable lighting end segment 22 is provided by the wrapping material 30. Preferably, both ends of the segment 22 are open to expose the smokable material 26. The smokable lighting end segment 22 can be configured so that smokable material 26 and wrapping material 30 each extend along the entire length thereof.

[0012] Located downstream from the smokable lighting end segment 22 is a longitudinally extending, generally cylindrical heat generation segment 35. The heat generation segment 35 includes a heat source 40 circumscribed by insulation 42, which may be coaxially encircled by wrapping material 45. The heat source 40 preferably is configured to be activated by combustion of the smokable material 26. Ignition and combustion of the smoking material preferably provide a user with a desirable experience (with respect at least to flavor and time taken to light the smoking article 10). The heat generated as the smokable material is consumed most preferably is sufficient to ignite or otherwise activate the heat source 40.

[0013] The heat source 40 may include a combustible fuel element that has a generally cylindrical shape and can incorporate a combustible carbonaceous material. Carbonaceous materials generally have high carbon contents. Preferred carbonaceous materials are composed predominately of carbon, typically have carbon contents of greater than about 60 percent, generally greater than about 70 percent, often greater than about 80 percent, and frequently greater than about 90 percent, on a dry weight basis. Fuel elements can incorporate components other than combustible carbonaceous materials (e.g., tobacco components, such as powdered tobaccos or tobacco extracts; flavoring agents; salts, such as sodium chloride, potassium chloride and sodium carbonate; heat stable graphite fibers; iron oxide powder; glass filaments; powdered calcium carbonate; alumina granules; ammonia sources, such as ammonia salts; and/or binding agents, such as guar gum, ammonium alginate and sodium alginate). A representative fuel element has a length of about 12 mm and an overall outside diameter of about 4.2 mm. A representative fuel element can be extruded or compounded using a ground or powdered carbonaceous material, and has a density that is greater than about 0.5 g/cm³, often greater than about 0.7 g/cm³, and frequently greater than about 1 g/cm³, on a dry weight basis. See, for example, the types of fuel element components, formulations and designs set forth in U.S. Pat. No. 5,551,451 to Riggs et al. and U.S. Pat. App. Pub. No. 2009/0090373 to Borschke et al. Particular embodiments of fuel elements are described below with reference to FIG. 3.

[0014] Another embodiment of a fuel element 40 may include a foamed carbon monolith formed in a foam process. In another embodiment, the fuel element 40 may be co-extruded with a layer of insulation 42, thereby reducing manufacturing time and expense. Still other embodiments of fuel elements may include those of the types described in U.S. Pat. No. 4,922,901 to Brooks et al. or U.S. Pat. App. Pub. No. 2009/0044818 to Takeuchi et al.

[0015] A representative layer of insulation 42 can comprise glass filaments or fibers. The insulation 42 can act as a jacket that assists in maintaining the heat source 40 firmly in place within the smoking article 10. The insulation 42 can be provided as a multi-layer component including an inner layer or mat 47 of non-woven glass filaments, an intermediate

layer of reconstituted tobacco paper 48, and an outer layer of non-woven glass filaments 49. These may be concentrically oriented or each overwrapping and/or circumscribing the heat source.

5 [0016] In one embodiment, the inner layer 47 of insulation may include a variety of glass or non-glass filaments or fibers that are woven, knit, or both woven and knit (such as, for example, so-called 3-D woven/knit hybrid mats). When woven, an inner layer 47 may be formed as a woven mat or tube. A woven or knitted mat or tube can provide superior control of air flow with regard to evenness across the insulation layer, including as any thermal-related changes may occur to the layer). Those of skill in the art will appreciate that a woven, knit, or hybrid material may provide more regular and consistent air spaces/ gaps between the filaments or fibers as compared to a non-woven material which is more likely to have irregularly closed and open spaces that may provide comparatively non-uniform and/or decreased air-flow. Various other insulation embodiments may be molded, extruded, foamed, or otherwise formed. Particular embodiments of insulation structures are described below with reference to FIGS. 4A-4G.

10 [0017] Preferably, both ends of the heat generation segment 35 are open to expose the heat source 40 and insulation 42 to the adjacent segments. The heat source 40 and the surrounding insulation 42 can be configured so that the length of both materials is co-extensive (i.e., the ends of the insulation 42 are flush with the respective ends of the heat source 40, and particularly at the downstream end of the heat generation segment). Optionally, though not necessarily preferably, the insulation 42 may extend slightly beyond (e.g., from about 0.5 mm to about 2 mm beyond) either or both ends of the heat source 40. Moreover, smoke produced when the smokable lighting end segment 22 is burned during use of the smoking article 10 can readily pass through the heat generation segment 35 during draw by the smoker on the mouth end 18.

15 [0018] The heat generation segment 35 preferably is positioned adjacent to the downstream end of the smokable lighting end segment 22 such that those segments are axially aligned in an end-to-end relationship, preferably abutting one another, but with no barrier (other than open air-space) therebetween. The close proximity of the heat generation segment 35 and the smokable lighting end segment 22 provides for an appropriate heat exchange relationship (e.g., such that the action of burning smokable material within the smokable lighting end segment 22 acts to ignite the heat source of the heat generation segment 35). The outer cross-sectional shapes and dimensions of the smokable lighting end and heat generation segments 22, 35, when viewed transversely to the longitudinal axis of the smoking article, can be essentially identical to one another (e.g., both appear to have a cylindrical shape, each having essentially identical diameters).

20 [0019] The cross-sectional shape and dimensions of the heat generation segment 35, prior to burning, can vary. Preferably, the cross-sectional area of the heat source 40 makes up about 10 percent to about 35 percent, often about 15 percent to about 25 percent of the total cross-sectional area of that segment 35; while the cross-sectional area of the outer or circumscribing region (comprising the insulation 42 and relevant outer wrapping materials) makes up about 65 percent to about 90 percent, often about 75 percent to about 85 percent of the total cross-sectional area of that segment 35. For example, for a cylindrical smoking article having a circumference of about 24 mm to about 26 mm, a representative heat source 40 has a generally circular cross-sectional shape with an outer diameter of about 2.5 mm to about 5 mm, often about 3 mm to about 4.5 mm.

25 [0020] A longitudinally extending, cylindrical aerosol-generating segment 51 is located downstream from the heat generation segment 35. The aerosol-generating segment 51 includes a substrate material 55 that, in turn, acts as a carrier for an aerosol-forming agent or material (not shown). For example, the aerosol-generating segment 51 can include a reconstituted tobacco material that includes processing aids, flavoring agents and glycerin.

30 [0021] The foregoing components of the aerosol-generating segment 51 can be disposed within, and circumscribed by, a wrapping material 58. A wrapping material 58 can be configured to facilitate the transfer of heat from the lighting end 14 of the smoking article 10 (e.g., from the heat generation segment 35) to components of the aerosol-generating segment 51. That is, the aerosol-generating segment 51 and the heat generation segment 35 can be configured in a heat exchange relationship with one another. The heat exchange relationship is such that sufficient heat from the heat source 40 is supplied to the aerosol-formation region to volatilize aerosol-forming material for aerosol formation. In some embodiments, the heat exchange relationship is achieved by positioning those segments in close proximity to one another. A heat exchange relationship also can be achieved by extending a heat conductive material from the vicinity of the heat source 40 into or around the region occupied by the aerosol-generating segment 51. Particular embodiments of substrates are described below with reference to FIG. 5.

35 [0022] A representative wrapping material 58 for the substrate material 55 may include heat conductive properties to conduct heat from the heat generation segment 35 to the aerosol-generating segment 51, in order to provide for the volatilization of the aerosol forming components contained therein. The substrate material 55 may be about 10 mm to about 22 mm in length, with certain embodiments being about 11 mm to about 12 mm in length, and other embodiments ranging up to about 21 mm.

40 [0023] The substrate material 55 can be provided from a blend of flavorful and aromatic tobaccos in cut filler form. Those tobaccos, in turn, can be treated with aerosol-forming material and/or at least one flavoring agent. The substrate material can be provided from a processed tobacco (e.g., a reconstituted tobacco manufactured using cast sheet or

papermaking types of processes) in cut filler form. Certain cast sheet constructions may include about 270 to about 300 mg of tobacco per 10 mm of linear length. That tobacco, in turn, can be treated with, or processed to incorporate, aerosol-forming material and/or at least one flavoring agent, as well as a burn retardant (e.g., diammonium phosphate or another salt) configured to help prevent ignition and/or scorching by the heat-generation segment. A metal inner surface of the wrapping material 58 of the aerosol-generating segment 51 can act as a carrier for aerosol-forming material and/or at least one flavoring agent.

[0024] In other embodiments, the substrate 55 may include a tobacco paper or non-tobacco gathered paper formed as a plug section. The plug section may be loaded with aerosol-forming materials, flavorants, tobacco extracts, or the like in a variety of forms (e.g., microencapsulated, liquid, powdered). A burn retardant (e.g., diammonium phosphate or another salt) may be applied to at least a distal/ lighting-end portion of the substrate to help prevent ignition and/or scorching by the heat-generation segment.

[0025] In these and/or other embodiments, the substrate 55 may include marumarized tobacco that has been formed into pellets or beads. Marumarized tobacco is known, for example, from U.S. Pat. No. 5,105,831 to Banerjee, et al. Marumarized tobacco may include about 20 to about 50 percent (by weight) tobacco blend in powder form, with glycerol (at about 20 to about 30 percent by weight), calcium carbonate (at about 40 to about 60 percent by weight), along with binder and flavoring agents. The beads, pellets, or other marumarized forms may be constructed in dimensions appropriate to fitting within a substrate section and providing for optimal air flow and production of desirable aerosol.

[0026] In these or other embodiments, the substrate 55 may include an open interior section 66 (as shown in FIG. 2). This open region may allow for aerosol condensation and improved transport/ aerosolization of vaporizable materials being released by heat during use of the smoking article. The surface of the interior opening 66 may be coated or otherwise treated with flavorants, tobacco extracts, or other materials to provide desirable flavors and/or organoleptic properties to the aerosol traveling therethrough.

[0027] In still other embodiments, the substrate 55 may include or be constructed from an extruded material. An extruded substrate may be formed in the same manner as described herein with reference to other extruded components. The extruded substrate may include, or may be essentially comprised of, tobacco, glycerin, water, and binder material, although certain formulation may exclude binder. The binder may be any binder commonly used for tobacco formulations including, for example, CMC (carboxymethyl cellulose) or guar gum, or it may include diammonium phosphate. In certain embodiments, a monolithic substrate may include about 10 to about 90 weight-percent tobacco, about 5 to about 50 weight-percent glycerin, about 1 to about 30 weight-percent water (after drying), and about 0 to about 10 weight-percent binder.

[0028] In one embodiment, the binder may be a custom binder designated here as "T-1." The T-1 binder includes tobacco, water, and diammonium phosphate. Exemplary T-1 formulations may include about 70 to about 80 percent water (by weight), about 1 to about 5 percent DAP (diammonium phosphate), and about 20 to about 30 percent tobacco. The T-1 may be made by combining those components in a hot water bath and stirring until a thickened slurry is formed. The slurry may be dried (e.g., in a vacuum oven), then ground up and used as a binder.

[0029] For extrusion, the component mix may be loaded into the barrel of a batch extruder. One end of the barrel preferably will be fitted with an extrusion die for shaping the extrudate as a plastic mass. A female extrusion die may be provided with a tapered surface to facilitate smooth flow of the plastic mass. Such a die may have, for example, five, seven, ten, or more slots and provide extrudate readily separable into segments about 5 to about 50 mm in length and about 0.5 to about 5 mm in diameter, with a mass of about 50 to about 1000 mg. One or more central steel pins may be used to provide one or more corresponding central passageways through the extrudate (e.g., as is shown in FIGS. 6A-6D, below). Exemplary extruded substrates will have a mass and density configured to provide a desirable flavor profile and air flow. An extruded or other monolithic substrate may have zero to about 15 slots on its surface and zero to about 14 longitudinal holes/channels through its body. A substrate with multiple internal channels may be extruded with a honeycomb, t-shaped, cross-shaped, or other cross-sectional geometry. A die pressure of about 3000 lbs. may be used for extrusion. The wet extruded rods preferably are placed on a well-ventilated tray for approximately one hour, and may then be carefully cut into lengths of about 5 mm to about 50 mm while preferably preserving the shape of the extrudate and the integrity of the axial hole(s).

[0030] It should also be appreciated that a substrate may be formed using the same formulations and components described herein for an extruded substrate. However, such an alternative embodiment may be formed by press-fit or molding/casting. Thus, the generic term "monolithic substrate" is used herein to include a substrate formed by extrusion or by one of those other methods. Reference to "extruded substrate" should be interpreted to include press-fit and/or molded/cast substrates of the same or substantially similar composition unless contextually excluded.

[0031] For preferred smoking articles, both ends of the aerosol-generating segment 51 are open to expose the substrate material 55 thereof. Components of the aerosol produced by burning the smokable lighting end segment 22 during use of the smoking article can readily pass through the aerosol-generating segment 51 during draw on the mouth end 18.

[0032] Together, the heat generating segment 35 and the aerosol-generating segment 51 form an aerosol-generation system 60. The aerosol-generating segment 51 is positioned adjacent to the downstream end of the heat generation

segment 35 such that those segments 51, 35 are axially aligned in an end-to-end relationship. Those segments can abut one another, or be positioned in a slightly spaced apart relationship, which may include a buffer region 53. The outer cross-sectional shapes and dimensions of those segments, when viewed transversely to the longitudinal axis of the smoking article 10, can be essentially identical to one another. The physical arrangement of those components preferably is such that heat is transferred (e.g., by means that includes conductive and convective heat transfer) from the heat source 40 to the adjacent substrate material 55, throughout the time that the heat source is activated (e.g., burned) during use of the smoking article 10.

[0033] A buffer region 53 may reduce potential scorching or other thermal degradation of portions of the aerosol-generating segment 51. The buffer region 53 may mainly include empty air space, or it may be partially or substantially completely filled with a non-combustible material such as, for example, metal, organic, inorganic, ceramic, or polymeric materials, or any combination thereof. The buffer regions may be from about 1 mm to about 10 mm or more in thickness, but often will be about 2 mm to about 5 mm in thickness.

[0034] The components of the aerosol-generation system 60 and the smokable lighting end segment 22 preferably are attached to one another, and secured in place using an overwrap material 64. For example, the overwrap material 64 can include a paper wrapping material or a laminated paper-type material that circumscribes each of the heat generation segment 35, at least a portion of outer longitudinally extending surface of the aerosol-generating segment 51, and at least a portion of an the lighting end segment 22 that is adjacent to the heat generation segment. The inner surface of the overwrap material 64 may be secured to the outer surfaces of the components it circumscribes by a suitable adhesive. Preferably, the overwrap material 64 extends over a significant portion of the length of the smokable lighting end segment 22.

[0035] The smoking article 10 preferably includes a suitable mouthpiece such as, for example, a filter element 65, positioned at the mouth end 18 thereof. The filter element 65 preferably is positioned at one end of the cigarette rod adjacent to one end of the aerosol-generating segment 51, such that the filter element 65 and the aerosol-generating segment 51 are axially aligned in an end-to-end relationship, abutting one another but without any barrier therebetween. Preferably, the general cross-sectional shapes and dimensions of those segments 51, 65 are essentially identical to one another when viewed transversely to the longitudinal axis of the smoking article. The filter element 65 may include filter material 70 that is overwrapped along the longitudinally extending surface thereof with circumscribing plug wrap material 72. In one example, the filter material 70 includes plasticized cellulose acetate tow, while in some examples the filter material may further include activated charcoal in an amount from about 20 to about 80 mg disposed as a discrete charge or dispersed throughout the acetate tow in a "Dalmatian type" filter. Both ends of the filter element 65 preferably are open to permit the passage of aerosol therethrough. The aerosol-generating system 60 preferably is attached to filter element 65 using tipping material 78. The filter element 65 may also include a crushable flavor capsule 76 of the type described in U.S. Patent No. 7,479,098 to Thomas et al. and U.S. Pat. App. Pub. Nos. 2006/0272663 to Dube et al.; and 2009/0194118 to Ademe et al.

[0036] The smoking article 10 may include an air dilution means, such as a series of perforations 81, each of which may extend through the filter element tipping material 78 and plug wrap material 72 in the manner shown, and/or which may extend to or into the substrate 55.

[0037] The overall dimensions of the smoking article 10, prior to burning, can vary. Typically, smoking articles 10 are cylindrically shaped rods having circumferences of about 20 mm to about 27 mm, have overall lengths of about 70 mm to about 130 mm - often about 83 mm to about 100 mm. Smokable lighting end segments 22 typically have lengths of about 3 mm to about 15 mm, but can be up to about 30 mm. The aerosol-generation system 60 has an overall length that can vary from about 20 mm to about 65 mm. The heat generation segment 35 of the aerosol-generation system 60 may have a length of about 5 mm to about 30 mm; and the aerosol-generating segment 51 of the aerosol-generation system 60 may have an overall length of about 10 mm to about 60 mm.

[0038] The amount of smokable material 26 employed to manufacture the smokable lighting end segment 22 can vary. Typically, the smokable lighting end segment 22, manufactured predominantly from tobacco cut filler, includes at least about 20 mg, generally at least about 50 mg, often at least about 75 mg, and frequently at least 100 mg, of tobacco material, on a dry weight basis. The packing density of the smokable material 26 within the smokable lighting end segment 22 preferably will be less than the density of the fuel element (e.g., about 100 to about 400 mg/cm³). Preferably, the smokable lighting end segment 22 essentially comprises smokable material 26, and does not include a carbonaceous fuel element component.

[0039] The combined amount of aerosol-forming agent and substrate material 55 employed in the aerosol-generating segment 51 can vary. The material preferably may be employed so as to fill the appropriate section of the aerosol-generating segment 51 (e.g., the region within the wrapping material 58 thereof) at a packing density of about 100 to about 400 mg/cm³.

[0040] During use, the smoker lights the lighting end 14 of the smoking article 10 using a match or cigarette lighter, in a manner similar to the way that conventional smoking articles are lit. As such, the smokable material 26 of the smokable lighting end segment 22 begins to burn. The mouth end 18 of the smoking article 10 is placed in the lips of

the smoker. Thermal decomposition products (e.g., components of tobacco smoke) generated by the burning smokable material 26 are drawn through the smoking article 10, through the filter element 65, and into the mouth of the smoker. That is, when smoked, the smoking article yields visible mainstream aerosol that resembles the mainstream tobacco smoke of traditional cigarettes that burn tobacco cut filler.

5 **[0041]** Burning the smokable lighting end segment 22 heats the fuel element 40 of the heat generation segment 35 such that it preferably will be ignited or otherwise activated (e.g., begin to burn). The heat source 40 within the aerosol-generation system 60 will burn, and provide heat to volatilize aerosol-forming material within the aerosol-generating segment 51 as a result of the heat exchange relationship between those two segments. Certain preferred heat sources 40 will not experience volumetric decrease during activation, while others may degrade in a manner that reduces their volume. Preferably, the components of the aerosol-generating segment 51 do not experience thermal decomposition (e.g., charring or burning) to any significant degree. Volatilized components are entrained in the air that is drawn through the aerosol-generating region 51. The aerosol so formed will be drawn through the filter element 65, and into the mouth of the smoker.

10 **[0042]** During certain periods of use, aerosol formed within the aerosol-generating segment 51, along with the aerosol (i.e., smoke) formed as a result of the thermal degradation of the smokable material 26 within the smokable lighting end segment 22, will be drawn through the filter element 65 and into the mouth of the smoker, along with the aerosol (i.e., smoke) formed as a result of the thermal degradation of the smokable material 26 within the smokable lighting end segment 22. Thus, the mainstream aerosol produced by the smoking article 10 includes tobacco smoke produced by the thermal decomposition of the tobacco cut filler as well as by the volatilized aerosol-forming material. For early puffs (i.e., during and shortly after lighting), most of the mainstream aerosol results from thermal decomposition of the smokable lighting end segment 22. For later puffs (i.e., after the smokable lighting end segment 22 has been consumed and the heat source 40 of the aerosol-generation system 60 has been ignited), most of the mainstream aerosol that is provided will be produced by the aerosol-generation system 60. When the smokable material 26 has been consumed, and the heat source 40 extinguishes, the use of the smoking article is ceased (i.e., the smoking experience is finished).

15 **[0043]** Referring to FIG. 2, a representative smoking article 10 in the form of a cigarette is shown. The smoking article 10 includes a heat generation segment 35 located at the lighting end 14, a filter segment 65 located at the other end (mouth end 18), and an aerosol-generating segment 51 (which may incorporate tobacco) that is located in between those two segments near the lighting end. The heat generation segment 35 of FIG. 2 can incorporate a generally cylindrical carbonaceous heat source circumscribed by insulation similar to what is shown in FIG. 1. The composition and dimensions of the various segments of the smoking article 10 in FIG. 2 are generally similar in manner with respect to those set forth previously with reference to FIG. 1, but without a charge of smokable material at the distal/lighting end, such that the fuel element is ignited directly rather than by a smokable material that was ignited and burned.

20 **[0044]** A filter element 65 preferably is attached to the cigarette rod so formed using a tipping material 78, in the general manner set forth previously with reference to FIG. 1. The smoking article optionally can be air-diluted by providing appropriate perforations 81 in the vicinity of the mouth end region 18, as is known in the art. Filters may include materials and may be manufactured by methods such as, for example, those disclosed in U.S. Pat. Publ. Nos. 2008/0029118 to Nelson et al.; 2008/0142028 to Fagg, et al.; 2008/0302373 to Stokes et al.; 2009/028867 to Hutchens et al.; and 2009/009037 to Thomas et al.

25 **[0045]** Flavor may be provided or enhanced by capsule or microcapsule materials on or within the substrate material 55 of the aerosol-generating segment 51 (FIG. 1 may be considered to have microcapsules present therein for illustrative purposes), the wrapping materials, the filter element 65, or any other component capable of holding and releasing flavorants, preferably with minimal thermal degradation that would undesirably alter the flavor. Other flavor components associated with a filter may also be used; see, for example, U.S. Pat. No. 5,724,997 to Fagg, et al.

30 **[0046]** Cigarettes described with reference to FIG. 2 may be used in much the same manner as those cigarettes commercially marketed under the trade name "Eclipse" by R. J. Reynolds Tobacco Company. See also the "Steam Hot One" cigarette marketed by Japan Tobacco Inc.

35 **[0047]** Smokable materials of the smokable lighting end segment most preferably incorporate tobacco of some form. Preferred smokable materials are composed predominantly of tobacco, based on the dry weights of those materials. That is, the majority of the dry weight of those materials, and the majority of the weight of a mixture incorporating those materials (including a blend of materials, or materials having additives applied thereto or otherwise incorporated therein) are provided by tobacco of some form. Those materials may be made all of tobacco material, and not incorporate any non-tobacco fillers, substitutes or extenders. The smokable material can be treated with tobacco additives that are traditionally used for the manufacture of cigarettes, such as casing and/or top dressing components. These tobacco components may be understood with reference to the examples and references set forth in U.S. Pat. App. Pub. No. 40 2007/0215167 to Crooks, et al.

45 **[0048]** Fuel elements of the heat generation segment may vary. Suitable fuel elements, and representative components, designs and configurations thereof, and manners and methods for producing those fuel elements and the components thereof, are set forth in U.S. Pat. Nos. 4,714,082 to Banerjee et al.; 4,756,318 to Clearman et al.; 4,881,556 to Clearman

et al.; 4,989,619 to Clearman et al.; 5,020,548 to Farrier et al.; 5,027,837 to Clearman et al.; 5,067,499 to Banerjee et al.; 5,076,297 to Farrier et al.; 5,099,861 to Clearman et al.; 5,105,831 to Banerjee et al.; 5,129,409 to White et al.; 5,148,821 to Best et al.; 5,156,170 to Clearman et al.; 5,178,167 to Riggs et al.; 5,211,684 to Shannon et al.; 5,247,947 to Clearman et al.; 5,345,955 to Clearman et al.; 5,469,871 to Barnes et al.; 5,551,451 to Riggs; 5,560,376 to Meiring et al.; 5,706,834 to Meiring et al.; and 5,727,571 to Meiring et al.; and U.S. Pat. App. Pub. Nos. 2005/0274390 and 2010/0065075 to Banerjee et al.

[0049] Fuel elements often comprise carbonaceous material and may include ingredients such as graphite or alumina, as well as high carbon content carbonaceous material. Carbonaceous fuel elements include the type that have been incorporated within those cigarettes commercially marketed under the trade names "Premier" and "Eclipse" by R. J. Reynolds Tobacco Company. See also the "Steam Hot One" cigarette marketed by Japan Tobacco Inc. Some other embodiments of fuel elements are set forth in U.S. Pat. Nos. 5,178,167 to Riggs et al. and 5,551,451 to Riggs et al., but certain embodiments may lack the sodium, graphite, and/or calcium carbonate set forth therein. Some fuel element embodiments may include a foamed carbon monolith. In another embodiment, the fuel element 40 may be co-extruded with a layer of insulation 42, thereby reducing manufacturing time and expense.

[0050] FIG. 3 shows an example of a carbonaceous fuel element 340 of the type disclosed above with reference to heat source 40. The following exemplary embodiments are described with reference thereto, but may be applied to fuel elements having different geometries and/or underlying compositions.

[0051] In a first embodiment, a fuel element 340 may be dip-coated with a mixture of two or more precursors. For example, copper nitrate hemi pentahydrate (available from Alfa Aesar) is mixed with equal weight of cerium nitrate hexahydrate (available from Alfa Aesar). The mixture of nitrates may then be dissolved in water (50% w/w). The fuel element 340 will then be coated with this aqueous solution, and the coated fuels are dried overnight at about 110°C.

[0052] The treated fuel element 340 is subjected to a heat treatment under nitrogen in a programmable Barnstead THERMOLYNE 62700 furnace by being heated to about 400°C at a ramp rate of about 5°C per minute and held for about four hours. The minimum temperatures at which a complete conversion of cerium nitrate hexahydrate to ceria and conversion of copper nitrate hemi pentahydrate to copper oxide take place may be determined by thermogravimetric analysis (TGA) using Model STA409 PC analyzer from Netzsch Instruments, Inc. Both transitions typically take place at or below about 300°C.

[0053] The fuel element 340 may be equilibrated under ambient conditions and inserted into a cigarette 10 similar in construction to that shown in FIG. 1. A cigarette 10 thus prepared may be smoked under 50/30/2 smoking conditions (i.e., 50 ml puffs of 2 second duration separated by 28 seconds) and CO in the mainstream measured by nondispersive infrared spectroscopy (NDIR), for example, using an NGA 2000 from Rosemount Inc. Treatment of the fuel with a mixture of cerium nitrate hexahydrate and copper nitrate hemi pentahydrate followed by heat treatment of the fuel will result in at least about 65% (e.g., about 68%) reduction of mainstream CO as compared to a control treated only with water. Nicotine and tar yields of the cigarettes will not be significantly affected by this modified fuel element. This reduction of CO is believed to result from a synergistic effect in the catalytic activity of the two metal oxides. The ratio of copper nitrate hemi pentahydrate and cerium nitrate hexahydrate may be further optimized for maximum catalytic activity. In other preparations of similar embodiments, the fuel element 340 can be dip-coated with the hydrates in sequence or the hydrates can be applied together or in sequence to the finished product either drop wise or by dipping the fuel end of the finished product into the hydrate solution.

[0054] In another embodiment described with reference to making a fuel element such as, for example, a fuel element 340 shown in FIG. 3, two or more metal nitrates or other metal oxide precursors may be mixed and dissolved in water. The solution may then be applied to graphite. The treated graphite may then be dried and calcined to yield metal-oxide coated graphite. Proper selection of metal oxides and processing conditions may yield synergistic catalytic activity. In variant embodiments of this application, the precursor solutions can be added sequentially to graphite, i.e. one metal nitrate solution is added to the graphite, dried and calcined as described before to convert the metal nitrate to metal oxide. The resulting metal oxide coated graphite may then be impregnated with a second metal oxide precursor solution followed by drying and calcination.

[0055] In yet another embodiment described with reference to making a fuel element such as, for example, a fuel element 340, about 7.5 grams of cerium (III) nitrate hexahydrate (available from Alfa Aesar) and about 7.5 grams of copper (II) nitrate hemi pentahydrate (available from Alfa Aesar) may be dissolved in about 7 ml of water. Next, about 18 grams of graphite powder (available Superior Graphite Inc.) may be impregnated with the metal nitrate solution and dried overnight in air. The treated graphite may then be calcined at about 300°C for about one hour under a nitrogen atmosphere in, for example, a programmable Barnstead THERMOLYNE 62700 furnace, where the ramp rate may be set at about 5°C/minute. Calcination will lead to decomposition of both the metal nitrates to their respective metal oxides.

[0056] The metal oxide-coated graphite may then be ground in a pestle mortar and combined with about 72 grams of milled BKO carbon powder (available from Barnaby and Suttcliffe), and about 10 grams of guar gum. Further mixing may be done in, for example, a Sigma blade mixer (Teledyne) for about an hour at a low speed. Water may then be added to convert the powder into plastic dough by mixing for about two additional hours. Sufficient water preferably will

be added to ensure that the plastic mix is stiff enough to hold its shape after extrusion. The moisture content of the dough at this stage will typically be about 42 to 43% (w/w). The dough preferably will be aged overnight in a sealed container at room temperature.

5 [0057] For extrusion, the plastic mix may be loaded into the barrel of a batch extruder. One end of the barrel preferably will be fitted with an extrusion die for shaping the extrudate. A female extrusion die may be provided with a tapered surface to facilitate smooth flow of the plastic mass. Such a die may have, for example, five or seven slots and be about 4.2 mm in diameter. An optional central steel pin may be used to provide a central passageway through the extrudate (e.g., as is shown in FIGS. 4B-4C, below). A die pressure of about 3000 lbs. may be used for extrusion. The wet extruded rods preferably are placed on a well-ventilated tray for approximately one hour, and may then be carefully cut into about 10 12 mm lengths while preferably preserving the shape of the extrudate and the integrity of the axial hole. The cut fuel rods 340 may then be dried overnight at about room temperature. A cigarette 10 constructed using this embodiment and smoked under 60/30/2 smoking conditions may provide mainstream aerosol having its CO reduced by at least about 50% (for example, about 56%), compared to a cigarette with an untreated control fuel element.

15 [0058] Addition of metal oxide precursor solution to graphite occasionally may result in agglomeration of the metal oxide on the graphite surface, leading to reduced catalytic activity. Such agglomeration is believed due to the relatively low surface area and hydrophobic nature of the graphite surface. Adding carbon to graphite before impregnation with precursor solution will minimize agglomeration of the metal oxide and result in a higher catalytic activity. In another embodiment, about 18 grams of graphite may be mixed with about 18 grams of milled BKO carbon. About 15 grams of copper nitrate hemi-penta-hydrate will be dissolved in about 7.5 ml of water. The mixture of graphite and carbon may then uniformly be impregnated with the copper nitrate solution and dried overnight at room temperature. The coated carbon-graphite mixture may thereafter be calcined at about 300°C for one hour under a nitrogen atmosphere. Fuel elements may be extruded and cut as described earlier. Cigarettes made with this metal nitrate-treated, carbon-graphite mixture will produce about 50% less CO in the mainstream smoke than a control cigarette using an untreated fuel element.

20 [0059] Compared to graphite, BKO milled carbon has a large surface area and consequently has a large adsorption capacity for the metal oxide catalyst precursor solution. This results in a highly uniform dispersion of the solution with minimum agglomeration of the metal oxide and thus a good activity of the metal oxide catalyst.

25 [0060] In still another embodiment, about 7.5 grams of copper nitrate hemi pentahydrate may be dissolved in 7 grams of water. About 18 grams of BKO milled carbon is impregnated with the solution and the mixture is dried overnight at room temperature. The treated carbon is calcined at about 300°C for one hour under nitrogen atmosphere. The calcined carbon is mixed with other fuel ingredients and is extruded into fuel rods as described before. A cigarette prepared with this fuel will have about a 50% reduction in mainstream CO compared to cigarettes produced with untreated fuel elements. In addition, cigarettes produced with the treated milled carbon fuel may be easier to light than cigarettes produced with fuel made with precursor-treated graphite described above.

30 [0061] The carbonaceous fuel elements commonly in use typically are extruded with a binder that is mostly organic in nature. Some commonly used binders include ammonium alginate, carboxymethyl cellulose, ethyl cellulose and guar gum. These binders provide good flow characteristics and improved physical and mechanical properties for processing the extrudate. However, upon combustion the extruded fuel may produce volatile organic compounds that negatively influence the taste, aroma, and chemistry of the smoke. These volatile organic compounds may nearly be eliminated if the extruded fuel is calcined prior to its use in the cigarette.

35 [0062] Accordingly, certain fuel embodiments may be extruded, having been formed using (by weight) about 30% calcium carbonate, about 10% guar gum, about 10% copper nitrate-treated graphite, and about 50% carbon. Treatment of graphite with catalyst precursor and the process of extrusion may be conducted as described above. The extruded fuel may be calcined at about 500°C for about two hours under nitrogen atmosphere. In test cigarettes constructed with the calcined fuels no significant impact was observed on the yields of tar, nicotine and carbon monoxide of the cigarette but significant improvements were noted with regard to taste and aroma of the mainstream and side stream smoke.

40 [0063] The fuel element preferably will be circumscribed or otherwise jacketed by insulation, or other suitable material. The insulation can be configured and employed so as to support, maintain and retain the fuel element in place within the smoking article. The insulation may additionally be configured such that drawn air and aerosol can pass readily therethrough. Examples of insulation materials, components of insulation assemblies, configurations of representative 45 insulation assemblies within heat generation segments, wrapping materials for insulation assemblies, and manners and methods for producing those components and assemblies, are set forth in U.S. Pat. Nos. 4,807,809 to Pryor et al.; 4,893,637 to Hancock et al.; 4,938,238 to Barnes et al.; 5,027,836 to Shannon et al.; 5,065,776 to Lawson et al.; 5,105,838 to White et al.; 5,119,837 to Banerjee et al.; 5,247,947 to Clearman et al.; 5,303,720 to Banerjee et al.; 5,345,955 to Clearman et al.; 5,396,911 to Casey, III et al.; 5,546,965 to White; 5,727,571 to Meiring et al.; 5,902,431 to Wilkinson et al.; and 5,944,025 to Cook et al. Insulation assemblies have been incorporated within the types of cigarettes commercially marketed under the trade names "Premier" and "Eclipse" by R. J. Reynolds Tobacco Company, and as "Steam Hot One" cigarette marketed by Japan Tobacco Inc.

55 [0064] FIGS. 4A-4G show different embodiments of insulation and fuel elements of a heat generation segment. In

certain embodiments, the insulation layer may include about 40 to about 50 percent (by weight) flue-cured tobacco lamina, about 20 to about 25 percent (by weight) water-soluble flue-cured tobacco stems extract, and about 20 to about 25 percent (by weight) wood pulp. In certain embodiments, the layer may include about 20 percent (by weight) carbon fiber, or about 20 percent (by weight) c-glass fiber. Preferred insulation layers thus formed include a treatment of about 5 to about 15 percent ammonium chloride (NH_4Cl), or of a 50/50 mixture of about 5 percent NH_4Cl and 5 percent sodium bicarbonate, by which is meant that the compound(s) will be present on the insulation layer sheet(s). These and other flame-retardants may be used in varying amounts. The insulation thus formed may be manufactured on a standard fourdrinier paper-making machine. Preferred insulation layer sheets thus formed will include a porosity of about 50 to about 150 cfm, a basis weight of about 80 to about 150 gsm, and a tensile strength of about 2000 to about 3000 gsm.

[0065] An insulation layer 42 may include an inner-facing geometry configured to engage and longitudinally retain a heat source 40. The engagement may be accomplished by a compression fit, co-extrusion of heat-source and insulation materials, or other methods known or developed in the art. Preferred heat sources include those that experience little if any volumetric decrease during a smoking activity. Certain heat sources may degrade and shrink longitudinally and/or circumferentially after being ignited, but - for preferred embodiments incorporating complementarily-shaped insulation elements - heat source embodiments including a matrix or other composition that generally retains volume after ignition are preferable.

[0066] FIGS. 4A-4B show, respectively, an end view of an insulation material 442 and heat source 440, and a perspective view of the heat source 440 without the insulation material 442. These elements are configured to interlockingly engage with a dovetail connection, where the inward-facing surface insulation material 442 includes an inward-facing geometry with a flared tongue protrusion 442c configured to engage in dovetail fashion with a complementarily-shaped flared groove 440c in an outward-facing recessed groove geometry of the heat source 440. The outward-facing geometry of the heat source 440 includes generally elongate rounded grooves 440d configured to facilitate airflow. In one embodiment, the dovetail groove 440c will be only one-half as wide at its narrowest portion (at the top/ edge of the outer heat source surface) as it is at the groove's widest portion. It should be appreciated that the flared tongue and groove may be constructed in variant fashion, by - for example - reversing the relative position of the dovetailed elements, orienting them other than longitudinally, and/or providing other interengaging tongue/groove geometries.

[0067] FIGS. 4C-4D show, respectively, an end view of a heat source 740, and a longitudinal section view of the heat source 740 with the insulation material 742. These elements are configured to interlockingly engage, with the insulation forming a retaining lip or shoulder 742a at the lighting end 714. That is, the inward-facing surface of the insulation material 742 includes an inward-facing geometry with a protrusion 742a configured to engage around a complementarily-shaped lighting end decreased-diameter cylindrical segment 740a of the heat source 740. The outward-facing geometry of the heat source 740 may include generally elongate rounded exterior grooves 740d that are configured to facilitate airflow. A heat source 740 may include one or more generally central longitudinal channels 741.

[0068] FIGS. 4E-4F show, respectively, a perspective view of a generally frustoconical heat source 840, and a longitudinal section view of the heat source 840 with an insulation material 842. These elements are configured to engage, with the inward-facing geometry of the insulation 842 forming a generally frustoconical space that houses and complementarily fits the heat source 840. The outward-facing geometry of the heat source 840 may include generally elongate rounded exterior grooves 840d that are configured to facilitate airflow. In many embodiments, five to eight such grooves may provide a desired airflow. This and other embodiments may include features described with reference only in various other embodiments herein. For example, a heat source 840 may include one or more generally central longitudinal channels 841.

[0069] FIG. 4G shows a longitudinal section view of the heat source 940 with an insulation material 942. These elements are configured to engage, with the inward-facing geometry of the insulation 942 forming a generally columnar space that houses and complementarily fits the heat source 940. The heat source 940 includes a flared base 940e opposite the lighting end 914 that is configured to longitudinally retain it within the insulation 942.

[0070] In one specific example, an insulation material may be constructed including about 50 percent (by weight) flue-cured tobacco lamina, about 25 percent (by weight) water-soluble flue-cured tobacco stems extract, and about 25 percent (by weight) wood pulp. After being formed into a sheet, the material may be treated with about 5 to about 15 percent ammonium chloride (NH_4Cl), or of a 50/50 mixture of about 5 percent NH_4Cl and 5 percent sodium bicarbonate. The insulation material may be manufactured as a sheet on a standard fourdrinier paper-making machine. The sheet insulation may include a porosity of about 50 to about 150 cfm, a basis weight of about 80 to about 150 gsm, and a tensile strength of about 2000 to about 3000 gsm.

[0071] In another example, an insulation material may be constructed including about 40 percent (by weight) flue-cured tobacco lamina, about 20 percent (by weight) water-soluble flue-cured tobacco stems extract, about 20 percent (by weight) wood pulp, and about 20 percent (by weight) c-glass fiber. After being formed into a sheet, the material may be treated with about 5 to about 15 percent ammonium chloride (NH_4Cl), or of a 50/50 mixture of about 5 percent NH_4Cl and 5 percent sodium bicarbonate. The insulation material may be manufactured as a sheet on a standard fourdrinier paper-making machine. The sheet insulation may include a porosity of about 50 to about 150 cfm, a basis weight of

about 80 to about 150 gsm, and a tensile strength of about 2000 to about 3000 gsm.

[0072] In still another example, an insulation material may be constructed including about 40 percent (by weight) flue-cured tobacco lamina, about 20 percent (by weight) water-soluble flue-cured tobacco stems extract, about 20 percent (by weight) wood pulp, and about 20 percent (by weight) carbon fiber. After being formed into a sheet, the material may be treated with about 5 to about 15 percent ammonium chloride (NH₄Cl), or of a 50/50 mixture of about 5 percent NH₄Cl and 5 percent sodium bicarbonate. The insulation material may be manufactured as a sheet on a standard fourdrinier paper-making machine. The sheet insulation may include a porosity of about 50 to about 150 cfm, a basis weight of about 80 to about 150 gsm, and a tensile strength of about 2000 to about 3000 gsm.

[0073] Flame/ burn retardant materials and additives useful in insulation may include silica, carbon, ceramic, metallic fibers and/or particles. When treating cellulosic or other fibers such as - for example - cotton, boric acid or various organophosphate compounds may provide desirable flame-retardant properties. In addition, various organic or metallic nanoparticles may confer a desired property of flame-retardancy, as may diammonium phosphate and/or other salts. Other useful materials may include organo-phosphorus compounds, borax, hydrated alumina, graphite, potassium tripolyphosphate, dipentaerythritol, pentaerythritol, and polyols. Others such as nitrogenous phosphonic acid salts, mono-ammonium phosphate, ammonium polyphosphate, ammonium bromide, ammonium chloride, ammonium borate, eth-anolammonium borate, ammonium sulphamate, halogenated organic compounds, thio-urea, and antimony oxides may be used but are not preferred agents. In each embodiment of flame-retardant, burn-retardant, and/or scorch-retardant materials used in insulation, substrate material and other components (whether alone or in any combination with each other and/or other materials), the desirable properties most preferably are provided without undesirable off-gassing or melting-type behavior.

[0074] An insulation fabric made by any one of the above processes preferably will have sufficient oxygen diffusion capability to sustain a smoking article such as a cigarette lit during a desired usage time. Accordingly the insulation fabric preferably will be porous by virtue of its construction. In knit, woven, or combined woven and knit constructions, the required porosity may be controlled by configuring the assembly machinery to leave sufficient (desirably sized) gaps between fibers to allow for oxygen diffusion into the heat source. For non-woven fabrics, which may not be porous enough to promote evenly sustained combustion, additional porosity may be achieved by perforations into the insulation by methods known in the art including, for example, hot or cold pin perforation, flame perforation, embossing, laser cutting, drilling, blade cutting, chemical perforation, punching, and other methods. Each of the buffer and the insulation may include non-glass material that is woven, knit, or a combination thereof, a foamed metal material, a foamed ceramic material, a foamed ceramic metal composite, and any combination thereof, and the material in the insulation may be the same as or different than that in the buffer.

[0075] The aerosol-forming material can vary, and mixtures of various aerosol-forming materials can be used, as can various combinations and varieties of flavoring agents (including various materials that alter the sensory and/or organoleptic character or nature of mainstream aerosol of a smoking article), wrapping materials, mouth-end pieces, filter elements, plug wrap, and tipping material. Representative types of these components are set forth in U.S. Pat. App. Pub. No. 2007/0215167 to Crooks, et al.

[0076] The substrate material can incorporate tobacco of some form, normally is composed predominantly of tobacco, and can be provided by virtually all tobacco material. The form of the substrate material can vary. In some embodiments, the substrate material is employed in an essentially traditional filler form (e.g., as cut filler). The substrate material can be otherwise formed into desired configurations. The substrate material can be used in the form of a gathered web or sheet, using the types of techniques generally set forth in U.S. Pat. No. 4,807,809 to Pryor et al. The substrate material can be used in the form of a web or sheet that is shredded into a plurality of longitudinally extending strands, using the types of techniques generally set forth in U.S. Pat. No. 5,025,814 to Raker. The substrate material can have the form of a loosely rolled sheet, such that a spiral type of air passageway extends longitudinally through the aerosol-generating segment. Representative types of tobacco containing substrate materials can be manufactured from mixtures of tobacco types; or from one predominant type of tobacco (e.g., a cast sheet-type or paper-type reconstituted tobacco composed primarily of burley tobacco, or a cast sheet-type or paper-type reconstituted tobacco composed primarily of Oriental tobacco).

[0077] The substrate material also can be treated with tobacco additives of the type that are traditionally used for the manufacture of cigarettes, such as casing and/or top dressing components. See, for example, the types of components set forth in U.S. Pat. Publication 2004/0173229 to Crooks et al.

[0078] The manner by which the aerosol-forming material is contacted with the substrate material (e.g., the tobacco material) can vary. The aerosol-forming material can be applied to a formed tobacco material, or can be incorporated into processed tobacco materials during manufacture of those materials. The aerosol-forming material can be dissolved or dispersed in an aqueous liquid, or other suitable solvent or liquid carrier, and sprayed onto that substrate material. See, for example, U.S. Patent Application Pub. No. 2005/0066986 to Nestor et al. The amount of aerosol-forming material employed relative to the dry weight of substrate material can vary. Materials including exceedingly high levels of aerosol-forming material can be difficult to process into cigarette rods using conventional types of automated cigarette manu-

facturing equipment.

[0079] Cast sheet types of materials may incorporate relatively high levels of aerosol-forming material. Reconstituted tobaccos manufactured using paper-making types of processes may incorporate moderate levels of aerosol-forming material. Tobacco strip and tobacco cut filler can incorporate lower amounts of aerosol-forming material. Various paper and non-paper substrates including gathered, laminated, laminated metal/ metallic, strips, beads such as alumina beads, open cell foam, foamed monolith, air permeable matrices, and other materials can be used within the scope of the invention. See, for example, U.S. Pat. Nos. 5,183,062; 5,203,355; and 5,588,446; each to Clearman.

[0080] In an embodiment according to the invention, the substrate is constructed in a novel multilayer fashion not including cast sheet construction, discussed here with reference to FIG. 5, which is a longitudinal section view of a cigarette 510 having a lighting end 514 and a mouth end 518. The substrate 555 (which may be used in other embodiment such as, for example, those discussed with reference to FIG. 1 and FIG. 2) includes a multilayer construction that may be stitch-bonded together.

[0081] A generally cylindrical or other-shaped substrate core 563 is centrally located in the substrate 555. The core 563 may include fabric (which may be treated with glycerin), and may also include an open longitudinal channel 566. A first outer layer 593 is disposed coaxially around (i.e., generally encircling) the substrate core 563. The first outer layer 593 is constructed including a fabric material such as, for example cotton or rayon. The fabric material has been treated with glycerin such that the glycerin is absorbed into the fabric, which may also include one or more flame-retardant, burn-retardant, and or scorch-retardant agents. The first outer layer 593 may be constructed as a plurality of layers including a multilayer construction with two or more layers.

[0082] An intermediate layer 592 is disposed generally coaxially/ concentrically around the first outer layer 593. The intermediate layer 592 is constructed as a layer of aromatic tobacco paper 592. The tobacco paper may be treated with flavoring agents, including those known for use in treating cut tobacco, tobacco papers, and generally within the tobacco art, as well as agents that may yet be developed. Preferred flavoring agents will help provide a mainstream aerosol including desirable flavor and aroma. A second outer layer 591 is disposed coaxially around the intermediate layer 592. Like the first outer layer 593, the second outer layer may be constructed as a plurality of layers including a multilayer construction with two or more layers. And, it is constructed of fabric material that has been treated with glycerin such that the glycerin is absorbed into the fabric, which may also include one or more flame-retardant, burn-retardant, and or scorch-retardant agents.

[0083] According to the invention, at least a portion of the first outer layer 593, second outer layer 591 and intermediate layer 592 is stitch-bonded together using a substrate heat-conducting material such as, for example, a metallic material (including as one example, aluminum). Stitch-bonding is known in the art of making non-woven fabrics (e.g., using barbed needles to entangle or otherwise bond fibers together to form a non-woven fabric or web). A stitch-bonding process may be used to form a three-layered substrate (e.g., as shown diagrammatically in FIG. 5) including at least one first outer layer 593, at least one intermediate layer 592, and at least one second outer layer 591 by joining one or more portions of two or more of the layers together. The heat-conducting material will help transmit heat from the heat-generation segment 535 in a matter configured to generate a desirable aroma and flavor from the substrate 555. This construction may be superior to cast sheet substrates, which may experience scorching and/or introduce undesirable flavors, tastes, aromas, etc. The presence of glycerin and the layered construction described with reference to the embodiment of FIG. 5 will help reduce scorching and minimize undesirable flavors and/or aromas associated with scorching. Embodiments with this and other substrate embodiments may be used with cigarettes including smokable material at the lighting end (e.g., as in FIG. 1).

[0084] In still other embodiments, the substrate portion of an aerosol-generation segment may include or may be constructed from an extruded or other monolithic material. An extruded substrate may be formed in the same manner as described herein with reference to other extruded components. The extruded or other monolithic substrate may include, or may be essentially comprised of, tobacco, glycerin, water, and binder material. In certain embodiments, a monolithic substrate may include about 10 to about 90 weight-percent tobacco, about 5 to about 50 weight-percent glycerin, about 1 to about 30 weight-percent water (before being dried and cut), and about 0 to about 10 weight-percent binder. It may also include a filler such as, for example, calcium carbonate and/or graphite.

[0085] For extrusion, the component mix may be loaded into the barrel of a batch extruder. One end of the barrel preferably will be fitted with an extrusion die for shaping the extrudate as a plastic mass. A female extrusion die may be provided with a tapered surface to facilitate smooth flow of the plastic mass. Such a die may have, for example, one, five, seven, ten, or more (or fewer) slots and provide for extrudate with about 5 to about 10 mm outer diameter, although the outer diameter may be larger and the substrate may not necessarily have a circular cross-section. One or more central steel pins may be used to provide one or more corresponding central passageways, which may include up to 14 or more such passages through the extrudate (e.g., as is shown in FIGS. 6A-6D, discussed below). The passages may be circular and/or polygonal in cross section, including providing a monolithic substrate having a generally honeycomb cross-sectional appearance.

[0086] Exemplary extruded and other monolithic substrates will have a mass and density configured to provide a

desirable flavor profile and air flow. A monolithic substrate may have zero to at least one to about 15 slots/grooves on its exterior surface and zero to about 14 longitudinal holes/channels through its body. Certain preferred embodiments may include at least one generally centered passage that is about 0.635 mm [0.025 inch] to about 2.54 mm [0.1 inch] in diameter. Generally, the passages may have internal diameters of less than 0.0254 mm [0.001 inch] to about 2.54 mm [0.1 inch]. A substrate with multiple internal channels may be extruded with a honeycomb geometry. A die pressure of about 3000 lbs. may be used for extrusion. The wet extruded rods preferably are placed on a well-ventilated tray for approximately one hour, and may then be carefully cut into lengths of about 5 mm to about 50 mm while preferably preserving the shape of the extrudate and the integrity of the axial hole(s).

The dried weight of the substrate units may range from about 50 to about 1000 mg.

[0087] Following extrusion, drying, and cutting to a desired length, the substrate may be assembled into a segmented smoking article such as an Eclipse-type cigarette using a manual assembly method or a cigarette-making machine (e.g., KDF or Protus by Hauni Maschinenbau AG). Smaller diameter monolithic substrate elements may be combined by being wrapped, adhered, or otherwise assembled together for use in a smoking article as described for other substrate embodiments herein. Preferred substrate wraps include foil paper, heavy-gauge paper, plug wrap, and/or cigarette paper.

[0088] FIG. 6A shows a generally cylindrical slotted/grooved monolithic substrate element 600 including a plurality of external grooves 602. FIG. 6B shows a grooved monolithic substrate element 610 including a plurality of external grooves 612 and a center hole 614 that extends longitudinally through its length. As shown in FIGS. 6A-6B, the grooves/slots do not have to be the same shape(s) as each other. FIG. 6C shows a generally cylindrical non-grooved monolithic substrate element 620 including a center-hole 624 (it should be appreciated that the "center-hole" may actually be off-center in certain embodiments). FIG. 6D shows a non-grooved monolithic substrate element 630 including a center-hole 634 and a plurality of holes/channels 636 configured in a honeycomb-like manner and extending through its length.

[0089] In one embodiment, a smoking article may be constructed with a monolithic substrate 763, described here with reference to FIG. 7, which is a longitudinal section view of a cigarette 710 having a lighting end 714 and a mouth end 718. The monolithic substrate 763 (which may be used in other embodiments such as, for example, those discussed with reference to FIGS. 1, 2, and 5) may be formed by any appropriate extrusion method and is shown with a center-hole 795 extending longitudinally therethrough. The monolithic substrate, cut to length may comprise about 1/16 to about 5/8 of the total length of the cigarette, often about 1/10 to about 1/2 thereof (e.g., a 10 mm, 12 mm, or 50 mm long substrate element in an 85 mm or 130 mm long cigarette). The substrate segment 755 of the cigarette body includes a hollow spacing tube 767 disposed between the substrate 767 and the filter 770. The filter 770 is shown as constructed with overlying layers of plug wrap 772 and tipping paper 778. The substrate 763 and tube 767 are surrounded by a wrapping material 758, which may be configured - for example - as a heat-conducting material (e.g., foil paper), heavy-gauge paper, plug wrap, or cigarette paper. A cylindrically-encompassing wrapping material 764 (such as, for example, cigarette paper or heavy-gauge paper) may be provided to connect the heat-generation segment 735, central substrate segment 755, and filter segment 765. The heat-generation segment 735 and other components may be constructed as described herein and elsewhere in this and other embodiments configured to be practiced within the scope of the present invention.

[0090] In another embodiment, a smoking article may be constructed with an elongate monolithic substrate 863, described here with reference to FIG. 8, which is a longitudinal section view of a cigarette 810 having a lighting end 814 and a mouth end 818. The elongate monolithic substrate 863 (which may be used in other embodiments) may be formed by any appropriate extrusion method and is shown with a center-hole 895 extending longitudinally therethrough. The filter 870 is shown as constructed with overlying layers of plug wrap 872 and tipping paper 878. The substrate 863 is surrounded by a wrapping material 858, which may be configured - for example - as a heat-conducting material (e.g., foil paper), heavy-gauge paper, plug wrap, or cigarette paper. A cylindrically-encompassing wrapping material (such as, for example, cigarette paper or heavy-gauge paper) may be provided to connect the heat-generation segment 835, central substrate segment 855 (consisting essentially of the substrate in this embodiment), and filter segment 865. The heat-generation segment 835 and other components may be constructed as described herein and elsewhere in this and other embodiments configured to be practiced within the scope of the present invention.

[0091] In one embodiment, a smoking article may be constructed with a monolithic substrate 963, described here with reference to FIG. 9, which is a longitudinal section view of a cigarette 910 having a lighting end 914 and a mouth end 918. The monolithic substrate 963 (which may be used in other embodiments) may be formed by any appropriate extrusion method and is shown with a center-hole 995 extending longitudinally therethrough. The cigarette body includes a tobacco rod 969 disposed between the substrate 967 and the filter 970. The filter 970 is shown as constructed with overlying layers of plug wrap 972 and tipping paper 978. The substrate segment 955, formed by the substrate 963 and tobacco rod 969, is surrounded by a wrapping material 958, which may be configured - for example - as a heat-conducting material (e.g., foil paper), heavy-gauge paper, plug wrap, or cigarette paper. A cylindrically-encompassing wrapping material (such as, for example, cigarette paper or heavy-gauge paper) may be provided to connect the heat-generation segment 935, central substrate segment 955, and filter segment 965. The heat-generation segment 935 and other components may be constructed as described herein and elsewhere in this and other embodiments configured to be

practiced within the scope of the present invention.

[0092] In other embodiments, an extruded or other monolithic substrate may be used in place of the substrates discussed herein with reference, for example, to FIGS. 1 and 2. For example, in one embodiment, the substrate 55 of FIG. 1 may be replaced with a monolithic substrate having one or more internal longitudinal channels and/or one or more external grooves. Various other filter designs may be used including perforated filters made of non-cellular acetate materials known in the art, as well as other filter configurations now known or forthcoming, all within the scope of the present invention. The other portions of cigarettes made with extruded or other monolithic substrates may also be modified in accordance with the state of the art, and still be practiced within the scope of the present invention. In the following examples, the monolithic substrate includes about 20 to about 60 weight-percent tobacco, about 20 to about 35 weight-percent glycerin, about 1 to about 20 weight-percent water, and about 1 to about 4 weight-percent binder.

EXAMPLE 1 - EXTRUDED SUBSTRATE IN SMOKING ARTICLE

[0093] In one example, smoking articles of about 83-85 mm in length were constructed using a heat source of about 12 mm in length, a substrate extruded according to the processes described herein and measuring about 10 mm in length, a hollow/void tube between the substrate and filter measuring about 50 mm in length, and a cellulose acetate filter about 10 mm in length. The exemplary extruded substrate was formed with ten external slots and a 0.813 mm [0.032 inch] center-hole, and it included the following components:

<u>Component</u>	<u>Mass (g)</u>	<u>Weight-Percent</u>
Flue-Cured Tobacco	15	11.8%
Burley Tobacco	9	7.1%
Turkish Tobacco	6	39.4%
CaCO ₃	50	39.4%
Glycerin	40	31.5%
CMC (binder)	2	1.6%
Water	5	3.9%

The physical construction of the smoking article of Example 1 may be understood with reference to the construction of the cigarette 710 shown in FIG. 7.

EXAMPLE 2 - EXTRUDED SUBSTRATE IN SMOKING ARTICLE

[0094] In another example, a smoking article was constructed using a heat source of about 12 mm in length, a substrate extruded according to the processes described herein and measuring about 50 mm in length, and a cellulose acetate filter about 10 mm in length with minimal space between the substrate and the filter. The exemplary extruded substrate was formed with ten external slots and a 0.813 mm [0.032 inch] center-hole, and it included the following components:

<u>Component</u>	<u>Mass (g)</u>	<u>Weight-Percent</u>
Flue-Cured Tobacco	50	14.4%
Burley Tobacco	30	8.6%
Turkish Tobacco	20	5.8%
CaCO ₃	100	28.8%
Glycerin	80	23.1%
CMC (binder)	12	3.5%
Water	55	15.9%

The physical construction of the smoking article of Example 2 may be understood with reference to the construction of the cigarette 810 shown in FIG. 8.

EXAMPLE 3 - EXTRUDED SUBSTRATE IN SMOKING ARTICLE

[0095] In another example, a smoking article was constructed using a heat source of about 12 mm in length, a substrate extruded according to the processes described herein and measuring about 10 mm in length, a tobacco rod between the substrate and filter measuring about 50 mm in length, and a cellulose acetate filter about 10 mm in length. The exemplary extruded substrate was formed with ten external slots and a 0.813 mm [0.032 inch] center-hole, and it included the following components:

<u>Component</u>	<u>Mass (g)</u>	<u>Weight-Percent</u>
Flue-Cured Tobacco	15	11.8%
Burley Tobacco	9	7.1%
Turkish Tobacco	6	4.7%
CaCO ₃	50	39.4%
Glycerin	40	31.5%
CMC (binder)	2	1.6%
Water	5	3.9%

The physical construction of the smoking article of Example 3 may be understood with reference to the construction of the cigarette 910 shown in FIG. 9.

EXAMPLE 4 - EXTRUDED SUBSTRATE IN SMOKING ARTICLE

[0096] In another example, a smoking article was constructed using a heat source of about 12 mm in length, a substrate extruded according to the processes described herein and measuring about 50 mm in length, and a cellulose acetate filter about 10 mm in length with minimal space between the substrate and the filter. The exemplary extruded substrate was formed with ten external slots and a 0.813 mm [0.032 inch] center-hole, and it included the following components:

<u>Component</u>	<u>Mass (g)</u>	<u>Weight-Percent</u>
Flue-Cured Tobacco	100	28.8%
Burley Tobacco	60	17.3%
Turkish Tobacco	40	11.5%
CaCO ₃	0	0%
Glycerin	80	23.1%
CMC (binder)	12	3.5%
Water	55	15.9%

The physical construction of the smoking article of Example 4 may be understood with reference to the construction of the cigarette 810 shown in FIG. 8.

EXAMPLE 5 - EXTRUDED SUBSTRATE IN SMOKING ARTICLE

[0097] In another example, a smoking article was constructed using a heat source of about 12 mm in length, a substrate extruded according to the processes described herein and measuring about 50 mm in length, and a cellulose acetate filter about 10 mm in length with minimal space between the substrate and the filter. The exemplary extruded substrate was formed with ten external slots and a 0.813 mm [0.032 inch] center-hole, and it included the following components:

<u>Component</u>	<u>Mass (g)</u>	<u>Weight-Percent</u>
Flue-Cured Tobacco	100	28.0%

EP 2 647 301 B1

(continued)

5

10

<u>Component</u>	<u>Mass (g)</u>	<u>Weight-Percent</u>
Burley Tobacco	60	16.8%
Turkish Tobacco	40	11.2%
Graphite	10	2.8%
Glycerin	80	22.4%
CMC (binder)	12	3.4%
Water	55	15.4%

15

The physical construction of the smoking article of Example 5 may be understood with reference to the construction of the cigarette 810 shown in FIG. 8.

EXAMPLES 6 and 7 - SUBSTRATES WITH T-1 BINDER

20

[0098] In another example, two substrates were formed according to processes described herein, and they included the following components:

25

30

<u>Component</u>	<u>Mass (g)(Example 6)</u>	<u>Mass (g)(Example 7)</u>
Tobacco	150	80
T-1 Binder (formed as 73.2 wt-pct water; 3.6% wt-pct DAP; and 23.2% wt-pct tobacco)	50	50
Glycerin	80	80
Water	45	55
CaCO ₃	---	70

35

EXAMPLES 8 and 9 - SUBSTRATES WITH DAP

[0099] In another example, two substrates may be formed by combining the following components in a heated mixer, then being extruded, press-fit, or molded/cast. The substrates may include the following mixtures of components:

40

45

<u>Component</u>	<u>Weight-Percent(Example 8)</u>	<u>Weight-Percent(Example 9)</u>
Tobacco	59.5%	36.8%
DAP	2.1%	2.0%
Glycerin	24.6%	23.9%
Water	13.8%	16.4%
CaCO ₃	---	20.9%

50

[0100] Cigarettes of the present invention may be air-diluted or ventilated such that the amount of air dilution for an air diluted cigarette may be about 10 percent to about 80 percent. As used herein, the term "air dilution" is the ratio (expressed as a percentage) of the volume of air drawn through the air dilution means to the total volume of air and aerosol drawn through the cigarette and exiting the mouth end portion of the cigarette. Higher air dilution levels can act to reduce the transfer efficiency of aerosol-forming material into mainstream aerosol.

55

[0101] Preferred embodiments of cigarettes of the present invention, when smoked, yield an acceptable number of puffs. Such cigarettes normally provide more than about 6 puffs, and generally more than about 8 puffs, per cigarette, when machine-smoked under standardized smoking conditions. Such cigarettes normally provide less than about 15 puffs, and generally less than about 12 puffs, per cigarette, when smoked under standardized smoking conditions. Standardized smoking conditions consist of 35 ml puffs of 2 second duration separated by 58 seconds of smolder.

[0102] Aerosols that are produced by cigarettes of the present invention are those that comprise air-containing components such as vapors, gases, suspended particulates, and the like. Aerosol components can be generated from burning tobacco of some form (and optionally other components that are burned to generate heat); by thermally decomposing tobacco caused by heating tobacco and charring tobacco (or otherwise causing tobacco to undergo some form of smolder); and by vaporizing aerosol-forming agent. As such, the aerosol can contain volatilized components, combustion products (e.g., carbon dioxide and water), incomplete combustion products, and products of pyrolysis.

[0103] Aerosol components may also be generated by the action of heat from burning tobacco of some form (and optionally other components that are burned to generate heat), upon substances that are located in a heat exchange relationship with tobacco material that is burned and other components that are burned. Aerosol components may also be generated by the aerosol-generation system as a result of the action of the heat generation segment upon an aerosol-generating segment. In some embodiments, components of the aerosol-generating segment have an overall composition, and are positioned within the smoking article, such that those components will have a tendency not to undergo a significant degree of thermal decomposition (e.g., as a result of combustion, smoldering or pyrolysis) during conditions of normal use.

[0104] Drawings in the figures illustrating various embodiments are not necessarily to scale. Some drawings may have certain details magnified for emphasis, and any different numbers or proportions of parts should not be read as limiting, unless so-designated by one or more claims.

Claims

1. A cigarette comprising:

a lighting end (14; 514) and a mouth end (18; 518);
 a mouth end piece segment (65) disposed at the mouth end;
 an aerosol-generation system disposed between the lighting end (14; 514) and the mouth end piece segment (65), the aerosol-generation system including
 a heat generation segment (535) disposed at the lighting end (14; 514) having a length including a heat source (400) configured to be activated by ignition of the lighting end (14; 514) and an insulation layer (42) of flame-retardant material disposed around the heat source (400);
 an aerosol-generating segment (51) incorporating aerosol-forming material, said aerosol-generating segment (51) having a length and being disposed between, but physically separate from, each of the heat generation segment (535) and the mouth end (18; 518), wherein the aerosol-generating segment (51) includes a substrate (55; 555) comprising
 a piece of outer wrapping material oriented to provide an overwrap (64) (i) around the aerosol-generating segment (51) for at least a portion of its length, and (ii) around the heat generation segment (535) for the length of that segment (535), those segments (51, 515) being connected together by the overwrap (64) to provide a cigarette rod; and
 the mouth end piece segment (65) being connected to the cigarette rod using tipping material (78),
characterized in that the substrate (55; 555) comprises a central core (563),
 a first outer layer (593) of a glycerin-treated fabric, coaxially disposed around the core (563),
 an intermediate layer (592) coaxially disposed around the first outer layer (593), the intermediate layer (592) including aromatic tobacco paper, and
 a second outer layer (591) of a glycerin-treated fabric, coaxially disposed around the intermediate layer (592), wherein at least a portion of the first (593), intermediate (592), and second (591) layers is stitch-bonded together with a substrate heat-conductive material.

2. The cigarette of Claim 1, wherein the first outer layer (593) comprises a plurality of layers, and/or wherein the second outer layer (591) comprises a plurality of layers.

3. The cigarette of Claim 1 or 2, wherein the heat generation segment (535) and the aerosol-generating segment (51) are disposed in a heat exchange relationship with one another and the insulation layer (42) provides an insulative layer about at least a portion of the heat source (400).

4. The cigarette of one of Claims 1 to 3, wherein the substrate heat-conductive material comprises aluminum.

5. The cigarette of one of Claims 1 to 4, wherein at least one of the first outer layer (593) and the second outer layer (591) comprises rayon, and/or wherein at least one of the first outer layer (593) and the second outer layer (591) comprises cotton.

6. The cigarette of one Claims 1 to 5, further comprising a buffer between the heat generation segment (535) and the aerosol-generating segment (51).
7. The cigarette of one of Claims 1 to 6, wherein the insulation layer (42) further comprises c-glass fiber, and/or wherein the insulation layer (42) comprises a carbon fiber material.
8. The cigarette of one of Claims 1 to 7, further comprising a smokable segment disposed at the lighting end (14; 514), said smokable segment (22) having a length and comprising a smokable material circumscribed by wrapping material (30).
9. The cigarette of one of Claims 1 to 8, wherein the central core (563) comprises an open space.
10. The cigarette of one of Claims 1 to 9, wherein the heat source (400) comprises a foamed structure comprising carbon.

Patentansprüche

1. Eine Zigarette, umfassend:

ein anzuzündendes Ende (14; 514) und ein Mundende (18; 518);
 ein Mundendestück-Segment (65), welches an dem Mundende angeordnet ist;
 ein Aerosolerzeugungssystem, welches zwischen dem anzuzündenden Ende (14; 514) und dem Mundendestück-Segment (65) angeordnet ist, wobei das Aerosolerzeugungssystem umfasst:
 ein Wärmeerzeugungssegment (535), welches an dem anzuzündenden Ende (14; 514) angeordnet ist und eine Länge aufweist und umfasst: eine Wärmequelle (400), welche durch Anzünden des anzuzündenden Endes (14; 514) aktivierbar ist, und eine Isolierlage (42) von flammhemmendem Material, welche um die Wärmequelle (400) herum angeordnet ist;
 ein Aerosolerzeugungssegment (51), welches ein aerosolbildendes Material enthält, wobei das Aerosolerzeugungssegment (51) eine Länge aufweist und zwischen dem Wärmeerzeugungssegment (535) und dem Mundende (18; 518), aber jeweils körperlich gesondert von diesen angeordnet ist, wobei das Aerosolerzeugungssegment (51) ein Substrat (55; 555) umfasst, welches umfasst:

ein Stück Außenumhüllungsmaterial, welches orientiert ist zum Bereitstellen einer Überumhüllung (64) (i) um das Aerosolerzeugungssegment (51) über mindestens einen Teil dessen Länge herum und (ii) um das Wärmeerzeugungssegment (535) über die Länge dieses Segments (535) herum, wobei diese Segmente (51, 515) mittels der Überumhüllung (64) miteinander verbunden sind, um einen Zigarettenstab bereitzustellen; und
 wobei das Mundendestück-Segment (65) unter Verwendung von Mundstückbelagpapier (78) mit dem Zigarettenstab verbunden ist,

dadurch gekennzeichnet, dass das Substrat (55; 555) umfasst: einen zentralen Kern (563), eine erste äußere Lage (593) eines mit Glycerin behandelten textilen Materials, welches koaxial um den Kern (563) herum angeordnet ist, eine Zwischenlage (592), welche koaxial um die erste äußere Lage (593) herum angeordnet ist, wobei die Zwischenlage (592) ein aromatisches Tabakpapier umfasst, und eine zweite äußere Lage (591) eines mit Glycerin behandelten textilen Materials, welches koaxial um die Zwischenlage (592) herum angeordnet ist, wobei mindestens ein Teil der ersten Lage (593), der Zwischenlage (592) und der zweiten Lage (591) mit einem Substrat-Wärmeleitmaterial vernadelt ist.

2. Die Zigarette nach Anspruch 1, wobei die erste äußere Lage (593) eine Mehrzahl von Lagen umfasst und/oder wobei die zweite äußere Lage (591) eine Mehrzahl von Lagen umfasst.
3. Die Zigarette nach Anspruch 1 oder 2, wobei das Wärmeerzeugungssegment (535) und das Aerosolerzeugungssegment (51) in einer Wärmeaustauschbeziehung zueinander stehen und wobei die Isolierlage (42) eine isolierende Lage um mindestens einen Teil der Wärmequelle (400) herum bereitstellt.
4. Die Zigarette nach einem der Ansprüche 1 bis 3, wobei das Substrat-Wärmeleitmaterial Aluminium umfasst.

EP 2 647 301 B1

5. Die Zigarette nach einem der Ansprüche 1 bis 4, wobei mindestens eine der Lagen erste äußere Lage (593) und zweite äußere Lage (591) Rayon umfasst und/oder wobei mindestens eine der Lagen erste äußere Lage (593) und zweite äußere Lage (591) Baumwolle umfasst.
6. Die Zigarette nach einem der Ansprüche 1 bis 5, ferner umfassend einen Puffer zwischen dem Wärmeerzeugungssegment (535) und dem Aerosol erzeugungssegment (51).
7. Die Zigarette nach einem der Ansprüche 1 bis 6, wobei die Isolierlage (42) ferner C-Glasfaser umfasst und/oder wobei die Isolierlage (42) ein Carbonfasermaterial umfasst.
8. Die Zigarette nach einem der Ansprüche 1 bis 7, ferner umfassend ein rauchbares Segment, welches an dem anzuzündenden Ende (14; 514) angeordnet ist, wobei das rauchbare Segment (22) eine Länge aufweist und ein rauchbares Material umfasst, welches von einem Umhüllungsmaterial (30) umschrieben ist.
9. Die Zigarette nach einem der Ansprüche 1 bis 8, wobei der zentrale Kern (563) einen offenen Raum umfasst.
10. Die Zigarette nach einem der Ansprüche 1 bis 9, wobei die Wärmequelle (400) eine geschäumte Struktur umfasst, welche Kohlenstoff umfasst.

Revendications

1. Cigarette comprenant :

une extrémité d'allumage (14 ; 514) et une extrémité buccale (18 ; 518) ;
un segment de pièce d'extrémité buccale (65) disposé au niveau de l'extrémité buccale ;
un système de génération d'aérosol disposé entre l'extrémité d'allumage (14 ; 514) et le segment de pièce d'extrémité buccale (65), le système de génération d'aérosol comprenant
un segment de génération de chaleur (535) disposé au niveau de l'extrémité d'allumage (14 ; 514) ayant une longueur comprenant une source de chaleur (400) configurée pour être activée par l'allumage de l'extrémité d'allumage (14 ; 514) et une couche d'isolation (42) en un matériau ignifugeant disposée autour de la source de chaleur (400) ;
un segment de génération d'aérosol (51) incorporant un matériau de formation d'aérosol, ledit segment de génération d'aérosol (51) ayant une longueur et étant disposé entre, mais en étant physiquement séparé de, chacun du segment de génération de chaleur (535) et de l'extrémité buccale (18 ; 518), le segment de génération d'aérosol (51) comprenant un substrat (55 ; 555) comprenant
une pièce de matériau d'enveloppement extérieur orientée pour former un surenveloppement (64) (i) autour du segment de génération d'aérosol (51) sur au moins une partie de sa longueur, et (ii) autour du segment de génération de chaleur (535) sur la longueur de ce segment (535), ces segments (51, 515) étant connectés ensemble par le surenveloppement (64) pour former une tige de cigarette ; et
le segment de pièce d'extrémité buccale (65) étant connecté à la tige de cigarette par utilisation d'un matériau d'embout (78),
caractérisé en ce que le substrat (55 ; 555) comprend un coeur central (563),
une première couche extérieure (593) en une étoffe traitée à la glycérine, disposée coaxialement autour du coeur (563),
une couche intermédiaire (592) disposée coaxialement autour de la première couche extérieure (593), la couche intermédiaire (592) comprenant un papier de tabac aromatique, et
une deuxième couche extérieure (591) en une étoffe traitée à la glycérine, disposée coaxialement autour du coeur intermédiaire (592), où au moins une partie des première (593), intermédiaire (592) et deuxième (591) couches est liée par couture conjointement avec un matériau de substrat thermiquement conducteur.

2. Cigarette selon la revendication 1, dans laquelle la première couche extérieure (593) comprend une pluralité de couches, et/ou dans laquelle la deuxième couche extérieure (591) comprend une pluralité de couches.
3. Cigarette selon la revendication 1 ou 2, dans laquelle le segment de génération de chaleur (535) et le segment de génération d'aérosol (51) sont disposés en relation d'échange de chaleur l'un avec l'autre et la couche d'isolation (42) réalise une couche isolante autour d'au moins une partie de la source de chaleur (400).

EP 2 647 301 B1

4. Cigarette selon l'une des revendications 1 à 3, dans laquelle le matériau de substrat thermiquement conducteur comprend de l'aluminium.
- 5 5. Cigarette selon l'une des revendications 1 à 4, dans laquelle au moins l'une parmi la première couche extérieure (593) et la deuxième couche extérieure (591) comprend de la rayonne, et/ou dans laquelle au moins l'une parmi la première couche extérieure (593) et la deuxième couche extérieure (591) comprend du coton.
- 10 6. Cigarette selon l'une des revendications 1 à 5, comprenant en outre un tampon entre le segment de génération de chaleur (535) et le segment de génération d'aérosol (51).
- 15 7. Cigarette selon l'une des revendications 1 à 6, dans laquelle la couche d'isolation (42) comprend en outre des fibres de verre c, et/ou dans laquelle la couche d'isolation (42) comprend un matériau en fibres de carbone.
8. Cigarette selon l'une des revendications 1 à 7, comprenant en outre un segment fumable disposé au niveau de l'extrémité d'allumage (14 ; 514), ledit segment fumable (22) ayant une longueur et comprenant un matériau fumable circonscrit par un matériau d'enveloppement (30).
- 20 9. Cigarette selon l'une des revendications 1 à 8, dans laquelle le coeur central (563) comprend un espace ouvert.
10. Cigarette selon l'une des revendications 1 à 9, dans laquelle la source de chaleur (400) comprend une structure expansée comprenant du carbone.

25

30

35

40

45

50

55

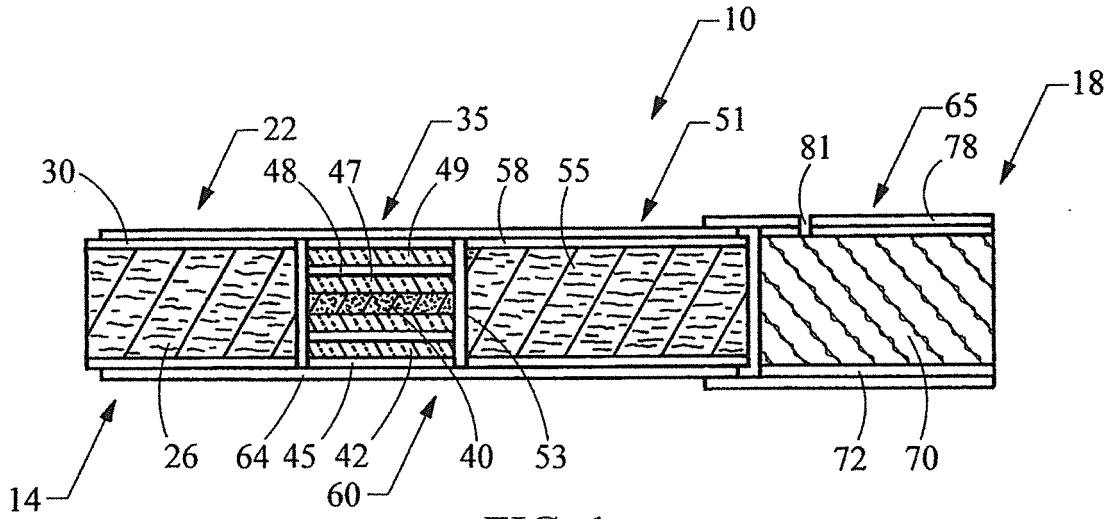

FIG. 1

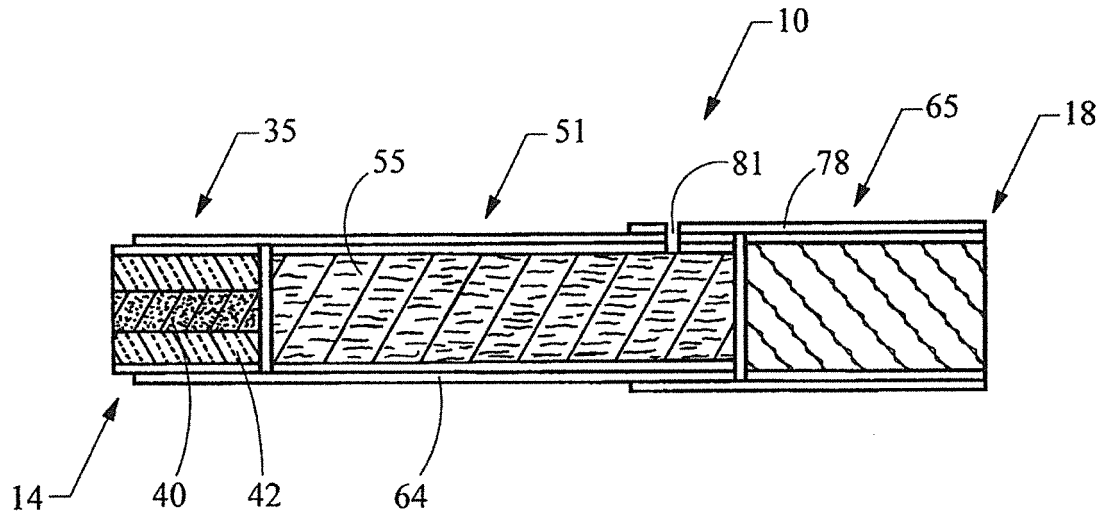

FIG. 2

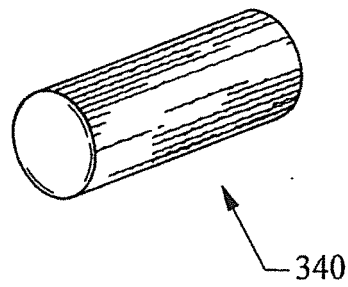

FIG. 3

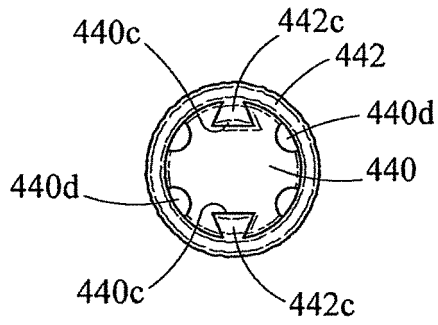

FIG. 4A

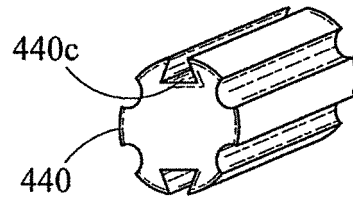

FIG. 4B

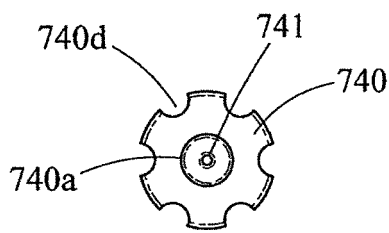

FIG. 4C

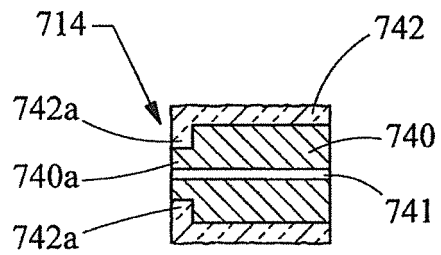

FIG. 4D

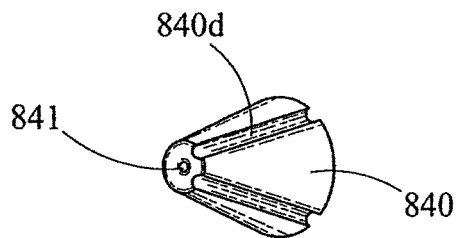

FIG. 4E

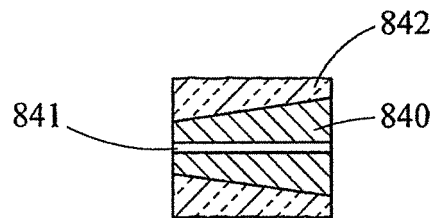

FIG. 4F

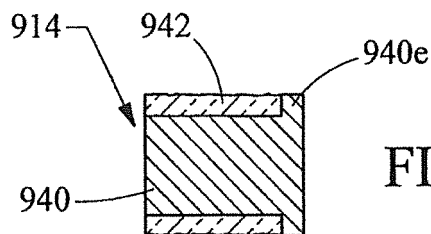

FIG. 4G

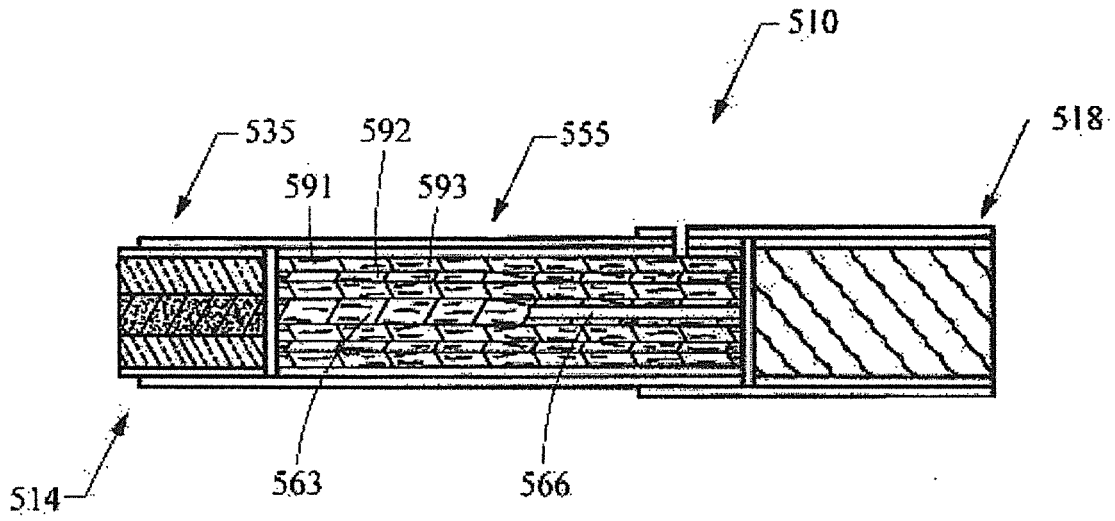

FIG. 5

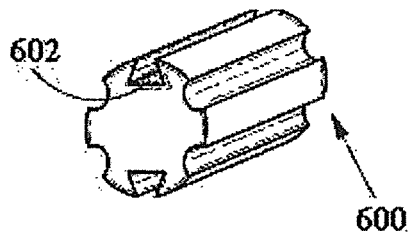

FIG. 6A

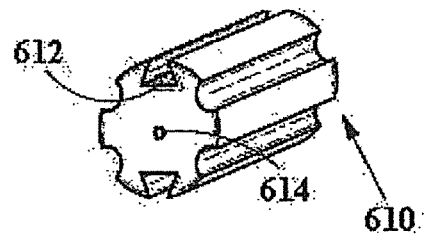

FIG. 6B

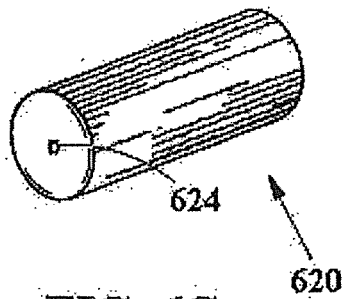

FIG. 6C

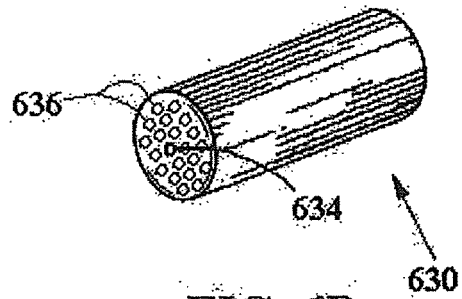

FIG. 6D

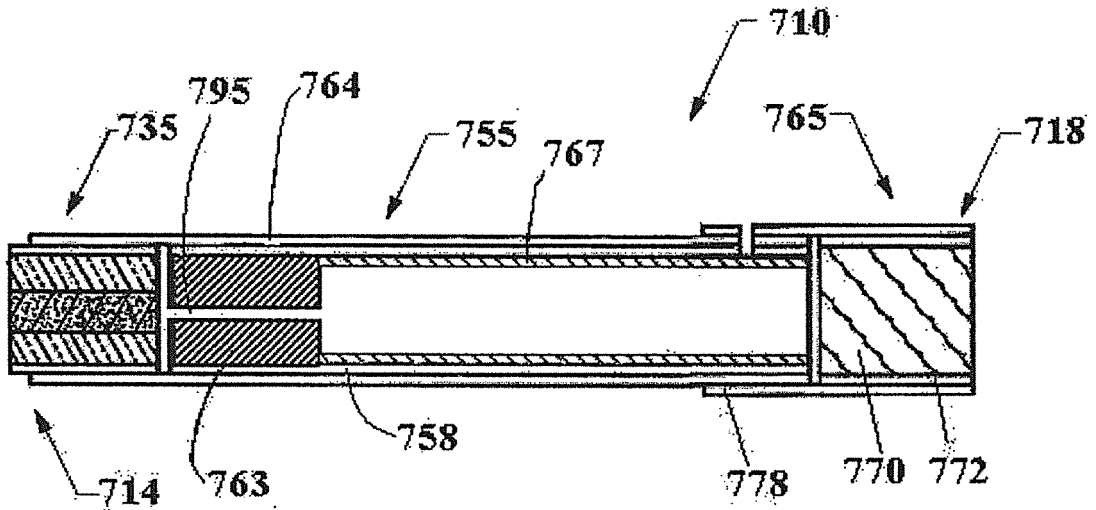

FIG. 7

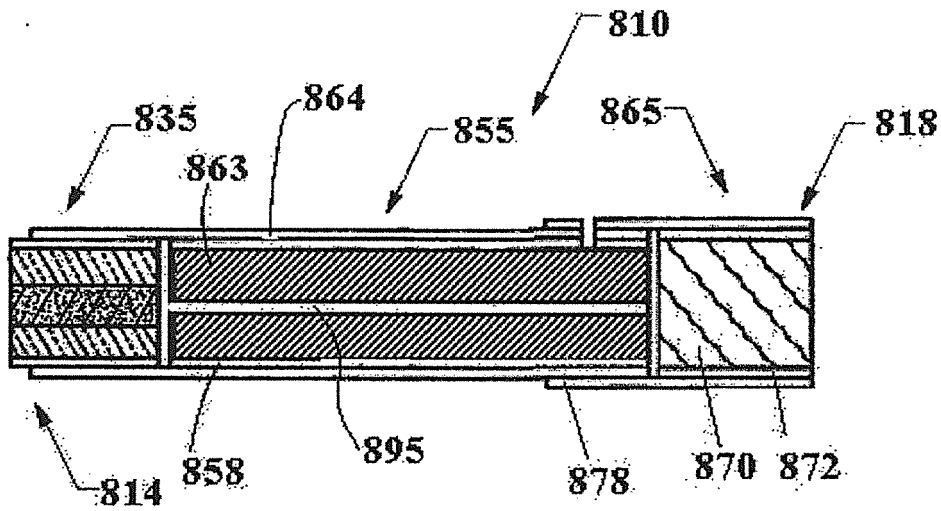

FIG. 8

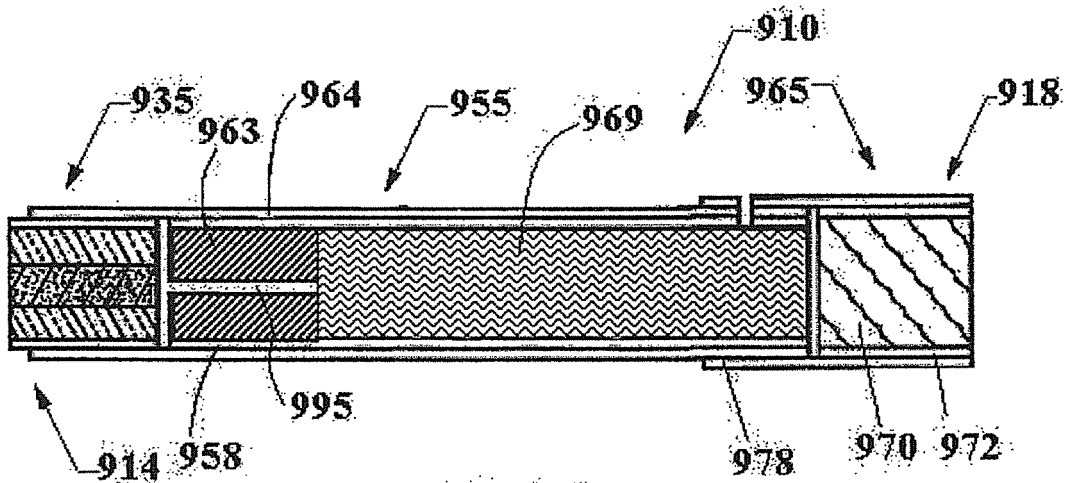

FIG. 9

REFERENCES CITED IN THE DESCRIPTION

This list of references cited by the applicant is for the reader's convenience only. It does not form part of the European patent document. Even though great care has been taken in compiling the references, errors or omissions cannot be excluded and the EPO disclaims all liability in this regard.

Patent documents cited in the description

- US 7503330 B, Borschke [0002]
- US 20050274390 A, Banerjee [0003] [0048]
- US 5285798 A, Banerjee [0004]
- US 7290549 B, Banerjee [0004]
- US 20080092912 A, Robinson [0004]
- US 54610709 A, Sebastian [0009]
- US 5551451 A, Riggs [0013] [0048] [0049]
- US 20090090373 A, Borschke [0013]
- US 4922901 A, Brooks [0014]
- US 20090044818 A, Takeuchi [0014]
- US 5105831 A, Banerjee [0025] [0048]
- US 7479098 B, Thomas [0035]
- US 20060272663 A, Dube [0035]
- US 20090194118 A, Ademe [0035]
- US 20080029118 A, Nelson [0044]
- US 20080142028 A, Fagg [0044]
- US 20080302373 A, Stokes [0044]
- US 2009028867 A, Hutchens [0044]
- US 2009009037 A, Thomas [0044]
- US 5724997 A, Fagg [0045]
- US 20070215167 A, Crooks [0047] [0075]
- US 4714082 A, Banerjee [0048]
- US 4756318 A, Clearman [0048]
- US 4881556 A, Clearman [0048]
- US 4989619 A, Clearman [0048]
- US 5020548 A, Farrier [0048]
- US 5027837 A, Clearman [0048]
- US 5067499 A, Banerjee [0048]
- US 5076297 A, Farrier [0048]
- US 5099861 A, Clearman [0048]
- US 5129409 A, White [0048]
- US 5148821 A, Best [0048]
- US 5156170 A, Clearman [0048]
- US 5178167 A, Riggs [0048] [0049]
- US 5211684 A, Shannon [0048]
- US 5247947 A, Clearman [0048] [0063]
- US 5345955 A, Clearman [0048] [0063]
- US 5469871 A, Barnes [0048]
- US 5560376 A, Meiring [0048]
- US 5706834 A, Meiring [0048]
- US 5727571 A, Meiring [0048] [0063]
- US 20100065075 A, Banerjee [0048]
- US 4807809 A, Pryor [0063] [0076]
- US 4893637 A, Hancock [0063]
- US 4938238 A, Barnes [0063]
- US 5027836 A, Shannon [0063]
- US 5065776 A, Lawson [0063]
- US 5105838 A, White [0063]
- US 5119837 A, Banerjee [0063]
- US 5303720 A, Banerjee [0063]
- US 5396911 A, Casey, III [0063]
- US 5546965 A, White [0063]
- US 5902431 A, Wilkinson [0063]
- US 5944025 A, Cook [0063]
- US 5025814 A, Raker [0076]
- US 20040173229 A, Crooks [0077]
- US 20050066986 A, Nestor [0078]
- US 5183062 A [0079]
- US 5203355 A [0079]
- US 5588446 A [0079]

Non-patent literature cited in the description

- Tobacco Production, Chemistry and Technology. 1999 [0002]
- Premier. R. J. REYNOLDS. Eclipse. Tobacco Company [0003]
- R. J. REYNOLDS. Chemical and Biological Studies on New Cigarette Prototypes that Heat Instead of Burn Tobacco. Tobacco Company Monograph, 1988 [0003]
- *Inhalation Toxicology*, 2000, vol. 12 (5), 1-58 [0003]