



(11) **EP 2 666 961 A1**

(12) **EUROPEAN PATENT APPLICATION**

(43) Date of publication:
27.11.2013 Bulletin 2013/48

(51) Int Cl.:
F01C 1/22 (2006.01) F01C 21/10 (2006.01)

(21) Application number: **12169534.0**

(22) Date of filing: **25.05.2012**

(84) Designated Contracting States:
AL AT BE BG CH CY CZ DE DK EE ES FI FR GB GR HR HU IE IS IT LI LT LU LV MC MK MT NL NO PL PT RO RS SE SI SK SM TR
Designated Extension States:
BA ME

• **Bagnell, Jonathan Mark**
Shenstone, Lichfield WS14 0DT (GB)
• **Richmond, ROy**
Shenstone, Lichfield WS14 0DT (GB)

(71) Applicant: **UAV Engines Ltd**
Lichfield, Staffordshire WS14 0DT (GB)

(74) Representative: **Chapman, Helga Claire et al**
Chapman Molony
20 Staple Gardens
Winchester SO23 8SR (GB)

(72) Inventors:
• **Biddulph, Christopher John**
Shenstone, Lichfield WS14 0DT (GB)

(54) **Rotary machine core assembly and rotary machine**

(57) A rotary machine core assembly (10) comprising a rotor housing (12), first and second endplates (14, 16) and mechanical fixing elements (18a, 18b). The housing defines a trochoid bore (20) and has a plurality of pairs of fixing holes (24a, 24b) provided therein. A first fixing hole (24a) of each pair extends from one side (12a) of the housing and a second fixing hole (24b, 42b) extends from an opposing side (12b) of the housing. Each fixing hole extends part-way into the rotor housing. The fixing holes extend towards each other and have a depth such that their ends are spaced from each other. The endplates (14, 16) are located adjacent respective sides of the housing. Each endplate has a plurality of through holes (30, 32) provided in it which are correspondingly located with the fixing holes on the rotor housing. Each mechanical fixing element is located through a respective through hole in an endplate and is received in the respective fixing hole in the rotor housing.

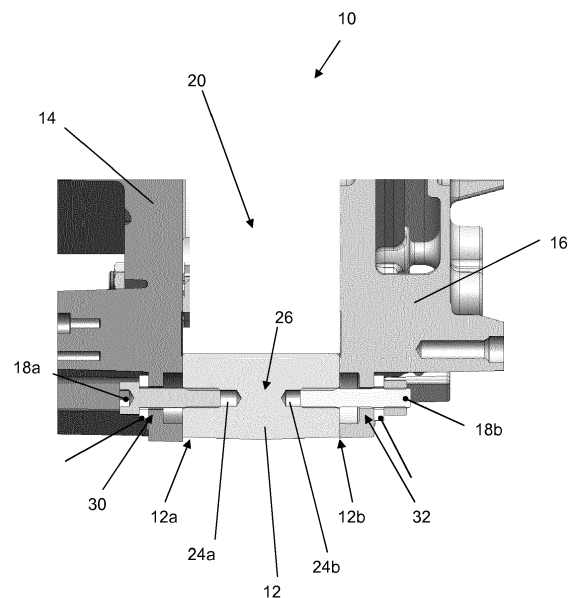

Fig. 1

EP 2 666 961 A1

Description

Technical Field

[0001] The invention relates to a rotary machine core assembly and to a rotary machine comprising the rotary machine core assembly.

Background

[0002] Conventionally the endplates of a rotary engine are held in place against the sides of the engine rotor housing using a through bolt or threaded stud located through each endplate and extending through the rotor housing. The rotor housing is made of Aluminium and the through bolts are typically made of steel alloy. The rotor housing defines a trochoid bore within which the engine rotor rotates during operation. When the engine is running there is a thermal distribution around the circumference of the rotor housing trochoid bore, a cooler region existing around the area of engine induction and a hotter region being associated with the ignition and power phase of the engine cycle. Typically, the regions of the trochoid which become hotter have either engine cooling fins or a liquid coolant passageway provided within the rotor housing to assist with cooling. Following running the engine there is a general, measurable distortion of the rotor housing caused by the heat generated during operation. In the area of the rotor housing which is hottest during operation a quite localised and large compressive distortion of the rotor housing is produced which causes a number of problems, as follows. A surface coating, such as nickel silicone is applied to the aluminium surface of the rotor housing defining the trochoid bore, to create a suitable wear surface. The distortion of the aluminium rotor housing leads to adhesion/cracking issues in surface coating, which ultimately leads to a loss in engine performance and/or increased engine maintenance. The distortion of the rotor housing reduces the effectiveness of the gas seal between the rotor housing and the endplate. The distortion of the rotor housing results in a reduction in the clamping load provided by the through bolt arrangement, which can result in increased surface fretting between the rotor housing and the endplate.

Statements of invention

[0003] A first aspect of the invention provides a rotary machine core assembly comprising:

a rotor housing defining a trochoid bore, the rotor housing having a plurality of pairs of fixing holes provided therein, each pair of fixing holes comprising a first fixing hole extending from one side of the rotor housing part-way into the rotor housing and a second fixing hole extending from an opposing side of the rotor housing part-way into the rotor housing, the fixing holes being generally co-axially aligned such that

they extend towards each other and each fixing hole having a depth such that the ends of the fixing holes are spaced from each other;

a first endplate located adjacent the one side of the rotor housing and a second endplate located adjacent the opposing side of the rotor housing, each endplate having a plurality of through holes provided in it, the through holes being correspondingly located with the fixing holes on the respective side of the rotor housing; and

a plurality of mechanical fixing elements, each mechanical fixing element being located through a respective through hole in one of the endplates and being received in the respective fixing hole in the rotor housing such that the ends of oppositely located fixing elements are spaced from each other.

[0004] The arrangement of the fixing holes and the mechanical fixing elements allows the rotor housing to expand when it becomes hotter during operation within a rotary machine, such as a rotary engine or a rotary compressor. The compressive distortion of the rotor housing which occurs in prior art rotary engines may thus be reduced or substantially eliminated. The associated adhesion/cracking issues in the surface coating of the trochoid bore may be reduced or substantially eliminated, which improve machine performance and/or reduce machine maintenance. The effectiveness of the gas seal between the rotor housing and the endplate may be maintained and the clamping load between the rotor housing and the endplates may be maintained, may reduce or substantially eliminate surface fretting between the rotor housing and one or both endplates.

[0005] In an embodiment, the rotor housing additionally has at least one single fixing hole provided therein, extending from a respective one of the sides of the rotor housing part-way into the rotor housing. At least one correspondingly located through hole is provided in a respective one of the endplates and at least one additional mechanical fixing element is located through the through hole in the respective endplate and is received in the single fixing hole.

[0006] In an embodiment, a plurality of single fixing holes are provided in the rotor housing, with correspondingly located through holes provided in the or each respective end plate and a plurality of mechanical fixing elements are provided, each located through a respective through hole in the respective endplate and received in the respective single fixing hole.

[0007] This may provide additional strength of attachment between the rotor housing and the end plates in regions of the rotor housing where it is not possible to provide a pair of fixing holes.

[0008] In an embodiment, each mechanical fixing element extends part-way into the respective fixing hole. This may increase the amount of thermally induced expansion which the rotor housing is able to accommodate.

[0009] In an embodiment, each fixing hole is a blind

hole and the rotor housing comprises solid metal between the ends of the oppositely located fixing holes of each pair. This may enable expansion of the rotor housing while maintaining mechanical strength and rigidity of the rotor housing. This may also provide improved heat transfer and less distortion of the rotor housing in the region of the fixing elements.

[0010] In an embodiment, a respective connecting bore is provided through the rotor housing between the ends of the oppositely located fixing holes of each pair. This may increase the amount of thermally induced expansion which the rotor housing is able to accommodate.

[0011] In an embodiment, the connecting bore has a diameter which is less than a diameter of each of the fixing holes of the respective pair. In an embodiment, the connecting bore is a tapping hole. Providing the connecting bore with a smaller diameter than the fixing holes may provide a 'stop' for the respective filing element at the end of each fixing hole.

[0012] In an embodiment, the connecting bore has a diameter which is greater than a diameter of each of the fixing holes of the respective pair.

[0013] In an embodiment, each mechanical fixing element comprises one of a threaded stud and a threaded bolt. In an embodiment, each fixing hole has a complementary internal thread provided on at least part of its length.

[0014] A second aspect of the invention provides a rotary machine comprising a rotary machine core assembly. The rotary machine core assembly comprises:

a rotor housing defining a trochoid bore, the rotor housing having a plurality of pairs of fixing holes provided therein, each pair of fixing holes comprising a first fixing hole extending from one side of the rotor housing part-way into the rotor housing and a second fixing hole extending from an opposing side of the rotor housing part-way into the rotor housing, the fixing holes being generally co-axially aligned such that they extend towards each other and each fixing hole having a depth such that the ends of the fixing holes are spaced from each other;

a first endplate located adjacent the one side of the rotor housing and a second endplate located adjacent the opposing side of the rotor housing, each endplate having a plurality of through holes provided in it, the through holes being correspondingly located with the fixing holes on the respective side of the rotor housing; and

a plurality of mechanical fixing elements, each mechanical fixing element being located through a respective through hole in one of the endplates and being received in the respective fixing hole in the rotor housing such that the ends of oppositely located fixing elements are spaced from each other.

[0015] The arrangement of the fixing holes and the mechanical fixing elements allows the rotor housing to ex-

pand when it becomes hotter during operation of the rotary machine. The compressive distortion of the rotor housing which occurs in prior art rotary engines may thus be reduced or substantially eliminated. The associated adhesion/cracking issues in the surface coating of the trochoid bore may be reduced or substantially eliminated, which improve engine performance and/or reduce engine maintenance. The effectiveness of the gas seal between the rotor housing and the endplate may be maintained and the clamping load between the rotor housing and the endplates may be maintained, may reduce or substantially eliminate surface fretting between the rotor housing and one or both endplates.

[0016] In an embodiment, the rotary machine is a rotary engine or a rotary compressor.

[0017] In an embodiment, the rotor housing additionally has at least one single fixing hole provided therein, extending from a respective one of the sides of the rotor housing part-way into the rotor housing. At least one correspondingly located through hole is provided in a respective one of the endplates and at least one additional mechanical fixing element is located through the through hole in the respective endplate and is received in the single fixing hole.

[0018] In an embodiment, a plurality of single fixing holes are provided in the rotor housing, with correspondingly located through holes provided in the or each respective end plate and a plurality of mechanical fixing elements are provided, each located through a respective through hole in the respective endplate and received in the respective single fixing hole.

[0019] This may provide additional strength of attachment between the rotor housing and the end plates in regions of the rotor housing where it is not possible to provide a pair of fixing holes. In an embodiment, each mechanical fixing element extends part-way into the respective fixing hole. This may increase the amount of thermally induced expansion which the rotor housing is able to accommodate.

[0020] In an embodiment, each fixing hole is a blind hole and the rotor housing comprises solid metal between the ends of the oppositely located fixing holes of each pair. This may enable expansion of the rotor housing while maintaining mechanical strength and rigidity of the rotor housing. This may also provide improved heat transfer and less distortion of the rotor housing in the region of the fixing elements.

[0021] In an embodiment, a respective connecting bore is provided through the rotor housing between the ends of the oppositely located fixing holes of each pair. This may increase the amount of thermally induced expansion which the rotor housing is able to accommodate.

[0022] In an embodiment, the connecting bore has a diameter which is less than a diameter of each of the fixing holes of the respective pair. In an embodiment, the connecting bore is a tapping hole. Providing the connecting bore with a smaller diameter than the fixing holes may provide a 'stop' for the respective filing element at the

end of each fixing hole.

[0023] In an embodiment, the connecting bore has a diameter which is greater than a diameter of each of the fixing holes of the respective pair.

[0024] In an embodiment, each mechanical fixing element comprises one of a threaded stud and a threaded bolt. In an embodiment, each fixing hole has a complementary internal thread provided on at least part of its length.

Brief description of the drawings

[0025]

Figure 1 is a cross-sectional view of part of a rotary machine core assembly according to a first embodiment of the invention;

Figure 2 shows the rotor housing of the rotary machine core assembly of Figure 1;

Figure 3 is a cross-sectional view of part of a rotary machine core assembly according to a second embodiment of the invention;

Figure 4 is a cross-sectional view of part of a rotary machine core assembly according to a third embodiment of the invention; and

Figure 5 is a cross-sectional view of part of a rotary engine according to a fourth embodiment of the invention.

Detailed description

[0026] Referring to Figures 1 and 2, a first embodiment of the invention provides a rotary machine core assembly 10 comprising a rotor housing 12, a first endplate 14, a second endplate 16 and a plurality of mechanical fixing elements 18.

[0027] The rotor housing 12 defines a trochoid bore 20 for receiving a rotor (not shown) and comprises a plurality of cooling fins 22, arranged extending generally outwardly from the trochoid bore.

[0028] A plurality of pairs of fixing holes 24 are provided in the rotor housing; in this example 12 pairs of fixing holes are provided. Each pair of fixing holes comprises a first fixing hole 24a and a second fixing hole 24b. Each first fixing hole 24a extends from one side 12a of the rotor housing part-way into the rotor housing and each second fixing hole 24b extends from the opposing side 12b of the rotor housing part-way into the rotor housing. As seen most clearly in Figure 1, the fixing holes 24a, 24b of each pair are generally co-axially aligned such that they extend towards each other. Each fixing hole has a depth which is less than one half of the thickness of the rotor housing 12, such that the ends of the fixing holes of each pair are spaced from each other. Each fixing hole is provided with an internal thread. In this embodiment a region 26 of solid metal is provided between the ends of the fixing holes.

[0029] Two dowel location holes 28 are also provided in the rotor housing 12, each extending part-way through

the rotor housing.

[0030] The first endplate 14 is located adjacent the one side 12a of the rotor housing 12 and the second endplate 16 is located adjacent the opposing side 12b of the rotor housing. Each endplate 14, 16 has a plurality of through holes 30, 32 provided in it. In this example each endplate has 12 through holes 30, 32 provided in it, matching the number of pairs of fixing holes 24 in the rotor housing. The through holes are correspondingly located with the fixing holes on the respective side of the rotor housing, so that the through holes in each endplate are aligned with the respective fixing holes 24a, 24b in the rotor housing.

[0031] Each endplate 14, 16 is provided with two dowel pins 34, in the form of straight, tubular dowels, for location in the dowel location holes 28 in the rotor housing 12, to correctly align each endplate 14, 16 against the respective side of the rotor housing. In this example 12 mechanical fixing elements 18a, 18b are provided through each endplate 14, 16. Each mechanical fixing element 18a, 18b is located through a respective through hole 30, 32 in its respective endplate and is received in the respective fixing hole 24a, 24b in the rotor housing. In this embodiment each mechanical fixing element 18a, 18b has a length which is less than the combined depth of the respective through hole 30, 32 and the respective fixing hole 24a, 24b. The ends of oppositely located fixing elements 18a, 18b are therefore spaced from each other.

[0032] In this embodiment the mechanical fixing elements 18a located through the first endplate 14 each comprise externally threaded bolts. The mechanical fixing elements 18b located through the second endplate 16 each comprise externally threaded studs, with a fixing nut located at the external end of the stud 18b to secure the stud in place.

[0033] It will be appreciated that each of the mechanical fixing elements 18a, 18b may be either one of a threaded bolt or a threaded stud plus a nut. Other types of mechanical fixing elements may also be used.

[0034] The spacing of the ends of the fixing holes 24a, 24b and the mechanical fixing elements 18a, 18b allows the rotor housing 12 to expand when it becomes hotter during operation as part of a rotary machine, such as a rotary engine or a rotary compressor.

[0035] A second embodiment of the invention provides a rotary machine core assembly 40 as shown in Figure 3. The rotary machine core assembly 40 of this embodiment is similar to the rotary machine core assembly 10 of Figures 1 and 2, with the following modifications. The same reference numbers are retained for corresponding features.

[0036] In this embodiment the fixing holes 42a, 42b each comprise open ended holes. Respective connecting bores 44 are provided between the ends of the fixing holes 42a, 42b of each pair. The connecting bores 44 have a smaller diameter than the fixing holes 42a, 42b so that the mechanical fixing elements 18a, 18b cannot extend into the respective connecting bore 44. It will be

appreciated by the person skilled in the art that the connecting bores 44 may alternatively have a larger diameter than the fixing holes.

[0037] The provision of the connecting bores 44 may increase the amount of thermally induced expansion which the rotor housing 12 is able to accommodate.

[0038] A third embodiment of the invention provides a rotary machine core assembly 50 as shown in Figure 4. The rotary machine core assembly 50 of this embodiment is similar to the rotary machine core assembly 10 of Figures 1 and 2, with the following modifications. The same reference numbers are retained for corresponding features.

[0039] In this embodiment the fixing holes 58a, 58b have larger diameter openings at the respective sides 12a, 12b of the rotor housing 12. The through holes 54, 56 have correspondingly larger openings at their ends which meet the fixing holes.

[0040] The fixing holes 58a, 58b are spaced from each other, with a smaller separation, provided by a region 52 of solid metal between their ends.

[0041] A fourth embodiment of the invention provides a rotary machine 60 as shown in Figure 5. The rotary machine 60 of this embodiment takes the form of a rotary engine 60. It will be appreciated by the person skilled in the art that the rotary machine 60 may alternatively take the form of a rotary compressor.

[0042] The rotary engine 60 comprises a rotary machine core assembly 10 as shown in Figure 1 and a rotor 62. The rotor 62 is located within the trochoid bore 20 of the rotor housing 12 and is arranged to rotate within the trochoid bore during operation of the engine 60. The operation of rotary engines will be well known to the person skilled in the art and will not be described in further detail here.

[0043] It will be appreciated that the rotary engine 60 may alternatively comprise a rotary machine core assembly 40, 50 as shown in Figures 3 and 4.

Claims

1. A rotary machine core assembly (10, 40, 50) comprising:

a rotor housing (12) defining a trochoid bore (20), the rotor housing having a plurality of pairs of fixing holes (24a, 24b, 42a, 42b, 58a, 58b) provided therein, each pair of fixing holes comprising a first fixing hole (24a, 42a, 58a) extending from one side (12a) of the rotor housing part-way into the rotor housing and a second fixing hole (24b, 42b, 58b) extending from an opposing side (12b) of the rotor housing part-way into the rotor housing, the fixing holes being generally co-axially aligned such that they extend towards each other and each fixing hole having a depth such that the ends of the fixing holes are spaced

from each other;

a first endplate (14) located adjacent the one side of the rotor housing and a second endplate (16) located adjacent the opposing side of the rotor housing, each endplate having a plurality of through holes (30, 32, 54, 56) provided in it, the through holes being correspondingly located with the fixing holes on the respective side of the rotor housing; and

a plurality of mechanical fixing elements (18a, 18b), each mechanical fixing element being located through a respective through hole in one of the endplates and being received in the respective fixing hole in the rotor housing such that the ends of oppositely located fixing elements are spaced from each other.

2. A rotary machine core assembly as claimed in claim 1, wherein the rotor housing additionally has at least one single fixing hole provided therein, extending from a respective one of the sides (12a, 12b) of the rotor housing part-way into the rotor housing, and at least one correspondingly located through hole is provided in a respective one of the endplates (14, 16), and at least one additional mechanical fixing element is located through the through hole in the respective endplate and is received in the single fixing hole.
3. A rotary machine core assembly as claimed in claim 1 or claim 2, wherein each mechanical fixing element (18a, 18b) extends part-way into the respective fixing hole.
4. A rotary machine core assembly as claimed in any of claims 1 to 3, wherein each fixing hole (24a, 24b, 58a, 58b) is a blind hole and the rotor housing comprises solid metal (26, 52) between the ends of the oppositely located fixing holes of each pair.
5. A rotary machine core assembly as claimed in any of claims 1 to 3, wherein a respective connecting bore (44) is provided through the rotor housing between the ends of the oppositely located fixing holes (42a, 42b) of each pair.
6. A rotary machine core assembly as claimed in claim 5, wherein the connecting bore (42) has a diameter which is less than a diameter of each of the fixing holes (42a, 42b) of the respective pair.
7. A rotary machine core assembly as claimed in any preceding claim wherein each mechanical fixing element comprises one of a threaded stud (18b) and a threaded bolt (18a).
8. A rotary machine (60) comprising a rotary machine core assembly (10, 40, 50) as claimed in any pre-

ceding claim.

9. A rotary engine (60) comprising a rotary machine core assembly (10, 40, 50) as claimed in of claims 1 to 7. 5
10. A rotary compressor comprising a rotary machine core assembly (10, 40, 50) as claimed in of claims 1 to 7. 10

15

20

25

30

35

40

45

50

55

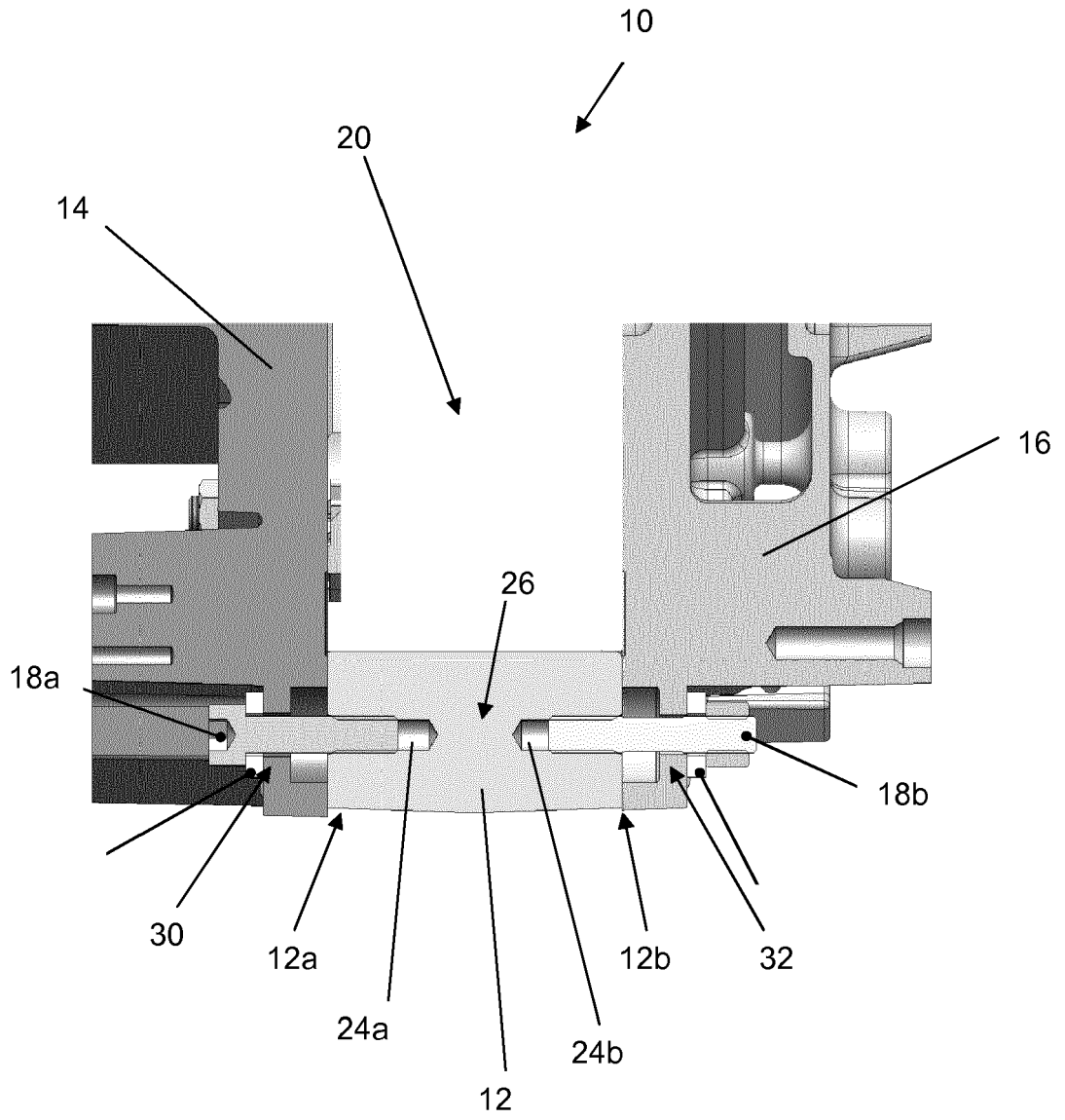

Fig. 1

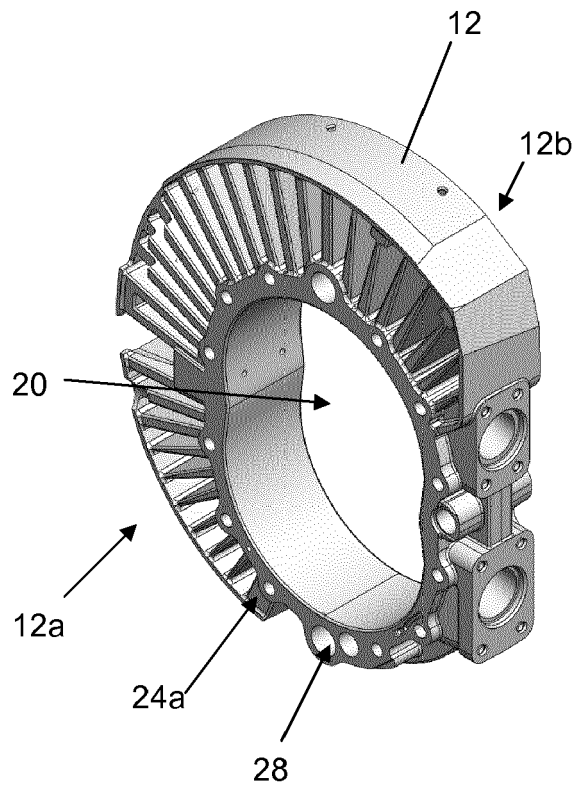

Fig. 2

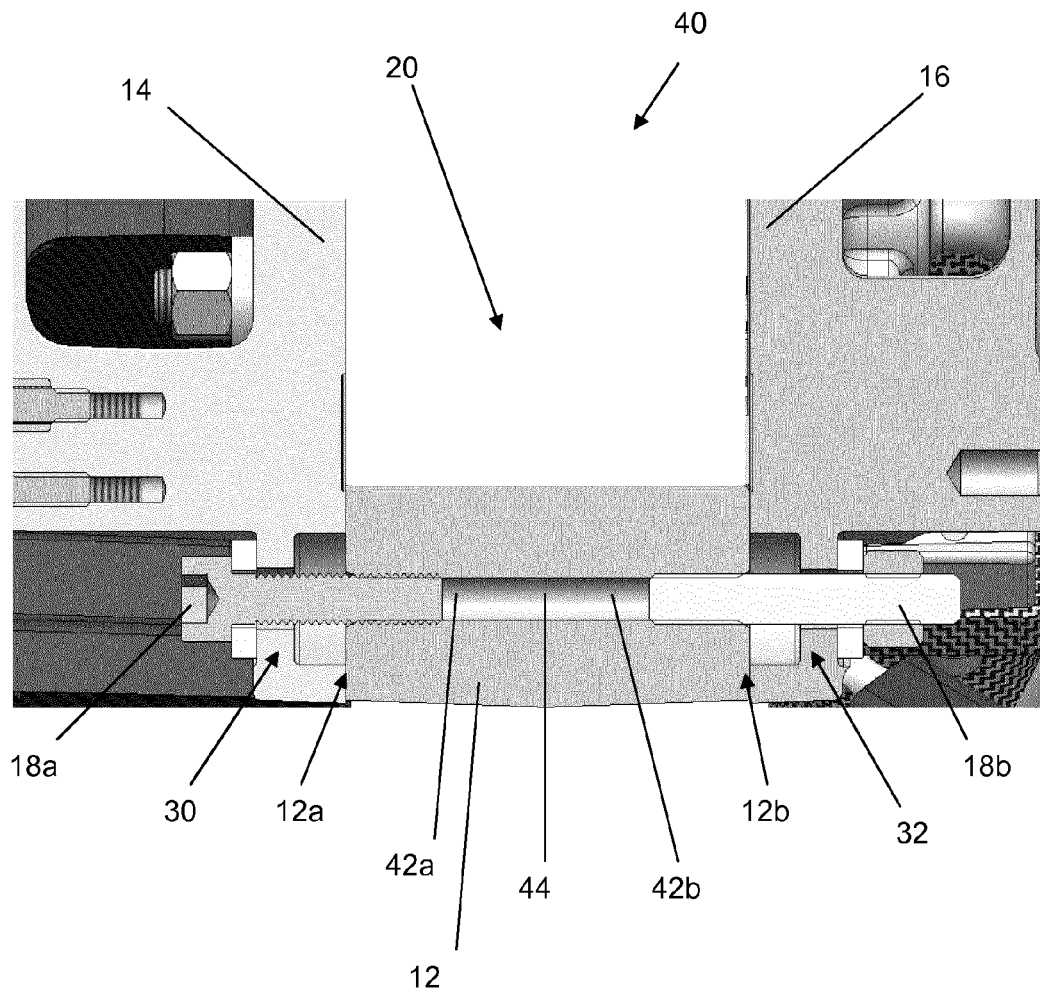

Fig. 3

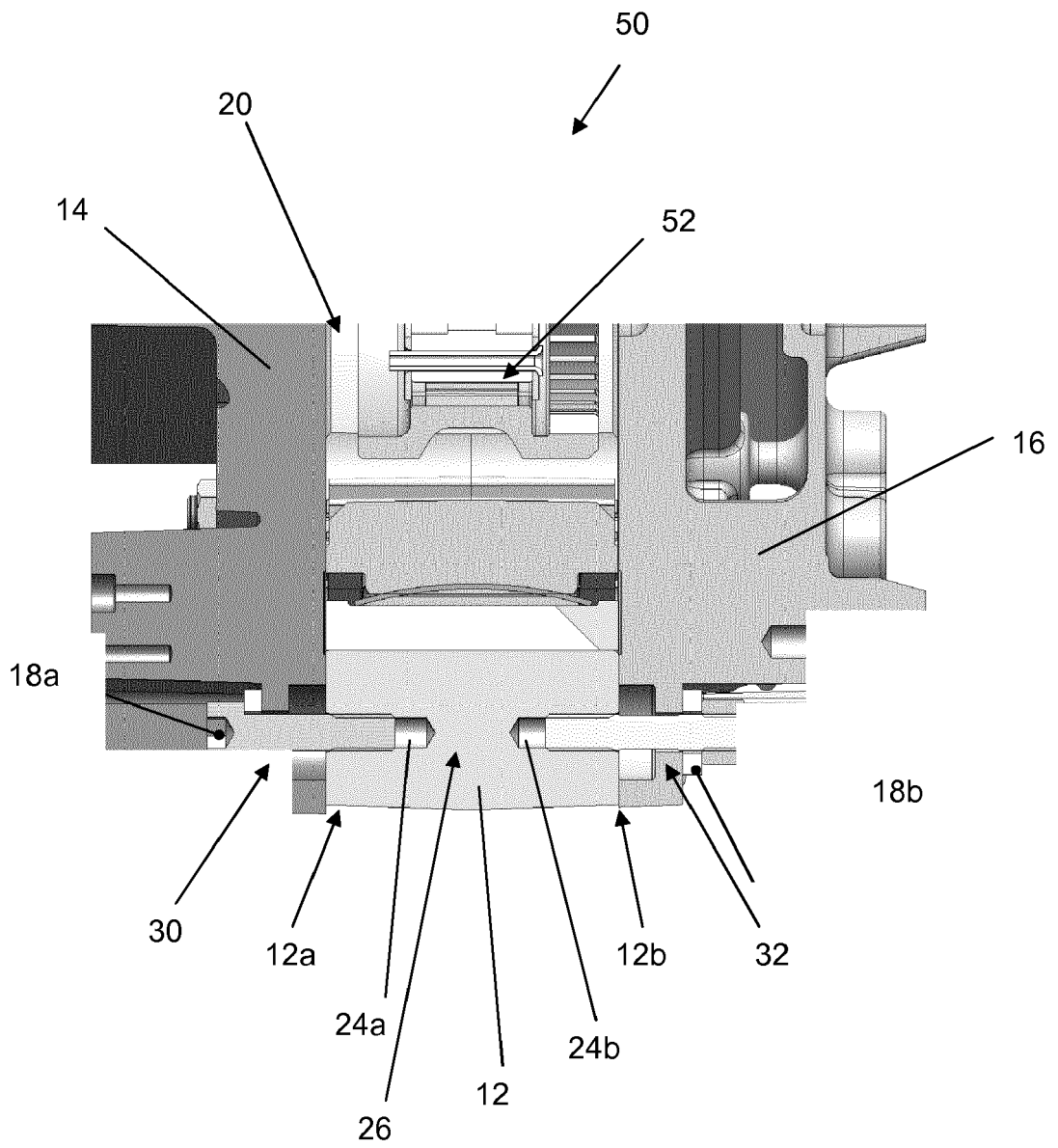

Fig. 5



EUROPEAN SEARCH REPORT

Application Number
EP 12 16 9534

DOCUMENTS CONSIDERED TO BE RELEVANT			
Category	Citation of document with indication, where appropriate, of relevant passages	Relevant to claim	CLASSIFICATION OF THE APPLICATION (IPC)
X	DE 198 12 853 A1 (JURASCHKA ERNST [DE]) 23 September 1999 (1999-09-23) * abstract; figures 1.1,1.2,1.3 * -----	1-4,7-10	INV. F01C1/22 F01C21/10
X	US 2009/084099 A1 (PARVOV TOTYO NEDYALKOV [US] ET AL) 2 April 2009 (2009-04-02) * paragraphs [0020], [0028]; figures * -----	1-4,7-10	
A	FR 2 376 956 A1 (BORSIG GMBH [DE]) 4 August 1978 (1978-08-04) * the whole document * -----	1-10	
A	DE 10 2008 015031 A1 (WANKEL SUPER TEC GMBH [DE]) 24 September 2009 (2009-09-24) * the whole document * -----	1-10	
			TECHNICAL FIELDS SEARCHED (IPC)
			F01C F04C
The present search report has been drawn up for all claims			
Place of search Munich		Date of completion of the search 18 October 2012	Examiner Descoubes, Pierre
CATEGORY OF CITED DOCUMENTS		T : theory or principle underlying the invention E : earlier patent document, but published on, or after the filing date D : document cited in the application L : document cited for other reasons ----- & : member of the same patent family, corresponding document	
X : particularly relevant if taken alone Y : particularly relevant if combined with another document of the same category A : technological background O : non-written disclosure P : intermediate document			

1
EPO FORM 1503 03.02 (P04C01)

ANNEX TO THE EUROPEAN SEARCH REPORT
ON EUROPEAN PATENT APPLICATION NO.

EP 12 16 9534

This annex lists the patent family members relating to the patent documents cited in the above-mentioned European search report.
The members are as contained in the European Patent Office EDP file on
The European Patent Office is in no way liable for these particulars which are merely given for the purpose of information.

18-10-2012

Patent document cited in search report	Publication date	Patent family member(s)	Publication date
DE 19812853	A1	23-09-1999	DE 19812853 A1
			WO 9956004 A1

US 2009084099	A1	02-04-2009	NONE

FR 2376956	A1	04-08-1978	AT 355704 B
			CA 1121776 A1
			DE 2700522 A1
			DK 1578 A
			FR 2376956 A1
			GB 1590923 A
			IT 1091857 B
			JP 1357479 C
			JP 53111514 A
			JP 61024556 B
			SE 432972 B
			SE 7800060 A
			US 4278409 A

DE 102008015031	A1	24-09-2009	NONE

EPO FORM P0459

For more details about this annex : see Official Journal of the European Patent Office, No. 12/82