

(19)



(11)

**EP 2 669 223 B1**

(12)

**EUROPEAN PATENT SPECIFICATION**

(45) Date of publication and mention of the grant of the patent:  
**28.05.2014 Bulletin 2014/22**

(51) Int Cl.:  
**B65H 18/02 (2006.01) B65H 19/22 (2006.01)**  
**B65H 19/30 (2006.01)**

(21) Application number: **12169769.2**

(22) Date of filing: **29.05.2012**

(54) **Method for winding fiber webs and device in a winder for winding fiber webs, especially for partial paper and board webs**

Verfahren zum Wickeln von Faserbahnen und Vorrichtung in einem Wickler zum Wickeln von Faserbahnen, insbesondere von Bahnen mit Papier- und Pappanteilen

Procédé et dispositif pour l'enroulement de bandes de fibres, notamment de bandes partielles de papier et de carton, notamment de bandes partielles de papier et de carton

(84) Designated Contracting States:  
**AL AT BE BG CH CY CZ DE DK EE ES FI FR GB GR HR HU IE IS IT LI LT LU LV MC MK MT NL NO PL PT RO RS SE SI SK SM TR**

(43) Date of publication of application:  
**04.12.2013 Bulletin 2013/49**

(73) Proprietor: **Valmet Technologies, Inc.**  
**02150 Espoo (FI)**

(72) Inventors:  
• **Eronen, Pekka**  
**FI-04430 Järvenpää (FI)**

• **Haapanen, Jaakko**  
**FI-04430 Järvenpää (FI)**

(74) Representative: **Berggren Oy Ab**  
**P.O. Box 16**  
**Antinkatu 3 C**  
**00101 Helsinki (FI)**

(56) References cited:  
**EP-A2- 1 310 447 EP-A2- 2 436 630**  
**GB-A- 2 136 403 US-A- 4 508 283**

**EP 2 669 223 B1**

Note: Within nine months of the publication of the mention of the grant of the European patent in the European Patent Bulletin, any person may give notice to the European Patent Office of opposition to that patent, in accordance with the Implementing Regulations. Notice of opposition shall not be deemed to have been filed until the opposition fee has been paid. (Art. 99(1) European Patent Convention).

## Description

**[0001]** The invention relates to a method for winding fiber webs, particularly for winding longitudinally slitted paper and board webs into partial web rolls, in which method the partial web rolls are wound in winding stations for winding partial web rolls by a nip between a winding roll and the partial web roll being formed.

**[0002]** The invention also relates to a device in a winder for winding fiber webs, particularly for winding longitudinally slitted paper and board webs into partial web rolls, in which device comprises winding stations for winding the partial web rolls, which winding stations are formed in connection with a winding roll.

**[0003]** It is known that a fiber web, e.g. paper, is manufactured in machines which together constitute a paper-manufacturing line which can be hundreds of meters long. Modern paper machines can produce over 450,000 tons of paper per year. The speed of the paper machine can exceed 2,000 m/min and the width of the paper web can be more than 11 meters.

**[0004]** In paper-manufacturing lines, the manufacture of paper takes place as a continuous process. A paper web completing in the paper machine is reeled by a reel-up around a reeling shaft i.e. a reel spool into a parent roll the diameter of which can be more than 5 meters and the weight more than 160 tons. The purpose of reeling is to modify the paper web manufactured as planar to a more easily processable form. On the reel-up located in the main machine line, the continuous process of the paper machine breaks for the first time and shifts into periodic operation.

**[0005]** The web of parent roll produced in paper manufacture is full-width and even more than 100 km long so it must be slit into partial webs with suitable width and length for the customers of the paper mill and wound around cores into so-called customer rolls before delivering them from the paper mill. This slitting and winding up of the web takes place as known in an appropriate separate machine i.e. a slitter-winder.

**[0006]** On the slitter-winder, the parent roll is unwound, the wide web is slit on the slitting section into several narrower partial webs which are wound up on the winding section around winding cores, such as spools, into customer rolls. When the customer rolls are completed, the slitter-winder is stopped and the wound rolls i.e. the so-called set is removed from the machine and new cores for new partial web rolls are to be transferred to winding stations for winding a new set of partial web rolls. Then, the process is continued with the winding of a new set. These steps are repeated periodically until paper runs out of the parent roll, whereby a parent roll change is performed and the operation starts again as the unwinding of a new parent roll.

**[0007]** Slitter-winders employ winding devices of different types depending on, inter alia, on the type of the fiber web being wound. On slitter-winders of the multistation winder type, the web is guided from the unwinding

via guide rolls to the slitting section where the web is slit into partial webs which are further guided to the winding roll/rolls on the winding stations into customer rolls to be wound up onto cores. Adjacent partial webs are wound up on different sides of the winding roll / on different winding rolls. Multistation winders have one to three winding rolls and in them each partial web is wound to a partial web roll in winding stations around cores that have been fed into the winder and often moved to the winding station by using different kinds of gripping means, which usually require complicated structures and actuators for achieving movements and positioning means for each winding station. During winding a winding nip is formed between the winding roll and the partial web roll to be wound.

**[0008]** In EP patent publication 0258533 is disclosed a prior art arrangement for introducing a winding tube (a winding core) into a winding machine with at least one supporting roller (a winding roll), at least two adjustable winding frames, with mutually opposed spindles receiving the winding tube, and with at least one winding tube gripper pivotable transversely relative to the axis of the supporting roller between a winding tube receiving position and a winding tube delivery position. The prior art arrangement also comprises a tube trough for transferring the tubes into the winding machine which is arranged respectively above a supporting roller in the region of the winding tube receiving position of the winding tube gripper. The winding tubes are fed into the winding machine in one line along the tube trough. One disadvantage in this kind of arrangement is that the tubes have tendency to adhere to each other at their ends, which causes separating problems in picking up by the grippers.

**[0009]** In US patent publication 4508283 is disclosed a prior art winding machine for winding a web slit lengthwise in which inserting devices for placing new core tubes into their respective winding beds are provided. In this prior art arrangement two adjacent insertion devices move two rows of cores one row on each device to respective winding beds. In GB patent application publication 2136403 a corresponding type of arrangement is disclosed.

**[0010]** An object of the invention is to create a device and a method for winding fiber webs where the problems relating to feeding cores into the winder have been eliminated or at least minimized.

**[0011]** An object of the invention is to create a new device and a new method for a winder for winding fiber webs relating to feeding cores into the winder.

**[0012]** An object of the invention is to provide a device in a winder and a method for winding fiber webs where the feeding of cores into the winder is reliable and fast.

**[0013]** To achieve the above-mentioned objects and those which come out later, the method according to the invention is mainly characterized by what is presented in the characterizing part of claim 1. The device according to the invention is mainly characterized by what is presented in the characterizing part of claim 5. Advantageous features are defined in depending claims.

**[0014]** According to the invention in the method for winding of partial webs the partial webs are wound as set into partial web rolls in a multistation type winder which comprises one or two winding rolls, in the method the cores are fed into the winder in pairs by a core pusher that pushes two adjacent cores in to the winder simultaneously and positions stepwise the cores to correct locations in the winder to be picked up to the winding stations on the winding rolls. In case an uneven number of cores is needed for a set of partial web rolls the core pusher may push and locate only one core at time.

**[0015]** According to the invention in the method first two adjacent cores are fed into the winder by the core pusher and one core is positioned for a winding station at one of the two winding rolls, the core pusher moves backwards and is reduced for one core only and the core pusher moves in the feed direction and positions the other core for a winding station on the other of the two winding rolls, the core pusher is reduced for return to be ready for transfer of the next two cores.

**[0016]** According to the invention the device in a winder for winding of partial webs in a multistation type winder, which comprises one or two winding rolls and an arrangement for feeding cores with a core pusher for pushing two adjacent cores into the winder simultaneously and for stepwise positioning the cores in the winder to be transferred to the winding stations on the winding rolls.

**[0017]** According to an advantageous feature of the invention a core storage and batching means for moving the cores from the core storage in to position for the core pusher feeding are located outside of the winder such that the cores for the winding stations at each of the two winding roll are loadable at same location.

**[0018]** According to advantageous aspects of the invention the cores are pushed into the winder by only one pusher pushing two adjacent cores simultaneously into the winder, which makes the arrangement cost effective and simple. The cores are transferred to the winder such that at the end of the feeding the cores for the set are in the winder for picking up to the winding stations in two adjacent rows at correct locations in respect of the winding stations.

**[0019]** To summarize the invention in the method and the arrangement for feeding cores into the winder the cores are fed into the winder in two rows, or lines by the core pusher and the cores to be fed next will be located for feeding during the feeding of the previous cores from the core storage and thus all cores for a set can be moved to correct locations for winding stations during the winding of the previous set of partial web rolls. The reducers reduce the core pusher for pushing one core only such that the other's location is not disturbed and also reduce the core pusher for movement back for next cores such that the cores waiting to be fed will not be dislocated.

**[0020]** By the invention a new device and a new method for a winder for winding fiber webs relating to feeding cores into the winder is achieved in which as a result the cores are in line at correct locations for winding stations.

**[0021]** Next, the invention will be described in more detail with reference to the figures of the enclosed drawing, to the details of which the invention is intended by no means to be narrowly limited.

Figures 1 - 8 schematically show an advantageous example of the invention in a winder with two winding rolls.

Figure 9 schematically shows a side view of a winder with two winding rolls with an advantageous example of the invention.

**[0022]** In the figures same reference signs are used for corresponding parts and part combinations unless otherwise mentioned.

**[0023]** In figure 1 is shown beginning stage of feeding new cores 31 into a winder. The area outside the winder is indicated by arrow 11 and the area inside the winder is indicated by arrow 10. Storage for new cores 31, for example a core table 30 is located next to transfer guides 24L, 24R, which are located adjacent to each other such that the adjacent cores located on them are not in contact. The transfer guide 24L is for a winding station at one of the winding rolls of the winder and the other transfer guide 24R is for a winding station at the other of the winding rolls of the winder. In connection with the core table 30 a core batching device 34 or corresponding means for batching and moving the cores from the core table 30, for example a robot, is provided for moving cores 31 onto the transfer guides 24L, 24R. In the figure 1 two cores 31 L, 31 R has been moved from the core table 30 by the core batching device 34 onto the transfer guides 24L, 24R. The core 31 L is for a winding station at one of the winding rolls of the winder and the other core 31 R if for a winding station at the other of the winding rolls of the winder. A core pusher 21 is in waiting location in the expander 20, which has means 27 for expanding the core pusher 21, i.e. the pusher 21, to pushing state, in which the pusher shoulders 25L, 25R are in opened position. In this example the means 27 for expanding the core pusher 21 consists of a V-shaped slot in the expander 20, which also serves as a stopper for the return movement back to waiting position for the pusher 21. Inside the winder area, indicated by arrow 10, are located at least two pairs of pusher reducers 22L, 22R and 23L, 23R pairwise on each side of the transfer guides 24L, 24R during winding of the previous set of partial web rolls. Different pairs of reducers are used depending on the positioning need of the cores.

**[0024]** In figure 2 further during winding of the previous set of partial web rolls the pusher 21 is pushing two adjacent cores 31 L, 31 R into the winder simultaneously on the transfer guides 24L, 24R and such that ends of the cores 31 L, 31 R are supported against the shoulders 25L, 25R of the pusher 21.

**[0025]** In figure 3 the pusher 21 has pushed the cores 31 L, 31 R along the transfer guides 24L, 24R to the location of the first core 31 L for picking up to the winding

station.

**[0026]** In figure 4 after pushing the first core 31 L to the picking up position the pusher 21 has backed up to the location of the pusher reducers 23L, 23R and the pusher reducer 23L on the side of the already located first core 31 L is opened to the reducing position such that the reducer actuator 26L is activated. The reducer actuators 26L, 26R consists of actuators, for example pneumatic or hydraulic cylinders. In the reducing position the reducer actuator 26L of the pusher reducer 23L extends crosswise over the transfer guide 24L on its side such that by moving the pusher 21 in return movement the reducer actuator 26L pushes the shoulder 25L into reduced and withdrawn position, in which the shoulder 25L will not contact the end of the core 31 L on its side and the pusher 21 can be moved past the core 31 L without contacting it and without dislocating it.

**[0027]** In figure 5 the pusher 21 pushes the other core 31R into correct position for picking up to the winding station and the end of the core 31 R is supported against the shoulder 25R on the transfer guide 24R.

**[0028]** In figure 6 two cores 31 L, 31 R have been fed to correct location for picking up to winding stations and the pusher reducers 23L, 23R at both sides of the pusher 21 have been opened to reducing position such that the reducer actuators 26L, 26R of the pusher reducer 23L, 23R extend crosswise over both transfer guides 24L, 24R such that while moving the pusher 21 in return movement the reducer actuator 26R pushes also the shoulder 25R into reduced and withdrawn position so that the pusher 21 can be moved in between the cores 31 L', 31 R' on the transfer guides 24L, 24R back to waiting position against the expander 20. The two cores 31 L', 31 R' to be fed into the winder and to be located at correct position for picking up to the winding station has been moved from the core table 30 by the core batching device 34 onto the transfer guides 24L, 24R during feeding and locating the previous cores 31 L, 31R.

**[0029]** In figure 7 the pusher 21 is returned to the waiting position in between the cores 31 L', 31 R' on the transfer guides 24L, 24R against the expander 20. The next two cores 31 L', 31 R' are waiting on the transfer guides 24L, 24R to be fed into the winder and to be located at correct position for picking up to the winding station.

**[0030]** In figure 8 the pusher 21 has returned to the waiting position against the expander 20 and the expanding means 27 has opened the shoulders 25L, 25R of the pusher 21 for pushing the next two cores 31 L, 31 R to correct positions into winder to be picked up to winding stations.

**[0031]** In figure 9 is shown a winder for winding of partial webs in to partial web rolls 36L, 26R around cores 31 L", 31 R". The winder is a multistation type winder which comprises two winding rolls 35L, 35R on which the winding stations are arranged successively alternating on each winding roll 35L, 35R. Transfer guides 24L, 24R along which cores 31 L, 31 R are pushed by the pusher

21 into the winder are located in the space between the winding stations.

**[0032]** As shown in the figures in the method the cores 31 are transferred in to the winder in pairs 31 L, 31 R by the pusher 21 that pushes two adjacent cores 31 L, 31 R in to the winder simultaneously and positions stepwise the cores 31 L, 31 R in the winder to be transferred to the winding stations on the winding rolls. In the method first two adjacent cores 31 L, 31 R are fed in to the winder by the core pusher 21 and one core 31 L is positioned for a winding station at one of the two winding rolls, the core pusher 21 moves backwards and is reduced by reducer actuator 26L of the reducer 23L for one core only by reducing one of its shoulders 25L and the core pusher 21 with one shoulder 25L reduced moves in the feed direction and positions the other core 31R for a winding station on the other of the two winding rolls, the other shoulder 25R of the core pusher 21 is reduced by the reducer actuator 26R of the other core reducer during movement backwards for return to for feeding of the next two cores 31 L', 31 R'. While the pusher 21 is locating the cores 31 L, 31 R in the winder the next cores 31 L', 31 R' are moved from the core table 30 onto the transfer guides 24L, 24R by the batching device 34 and thus the cores 31 L', 31 R' are ready to be fed into to winder as the core pusher 21 is returned. This sequence is repeated during winding of the previous set of partial web rolls 36L, 36R as many times needed for all cores for the winding of the next set of partial web rolls are in correct locations on the transfer guides 24L, 24R in the winder for pick-up to the winding stations. Cores are fed in pairs, i.e. two at the time unless an uneven number of cores is needed for winding a set of partial web rolls. In that case the pusher may move only one core at time. The cores 31 L, 31 R are transferred to the winder such that at the end phase of the feeding the cores 31 L, 31 R are in the winder for transfer to the winding stations in two adjacent rows at correct locations.

#### 40 Claims

1. Method for winding of partial webs, in which method the partial webs are wound around cores (31; 31 L", 31 R") to partial web rolls (35L, 35R) as set in winding stations by a nip between a winding roll and the partial web roll being formed in a multistation type winder, which comprises one or two winding rolls (35L, 35R) and arrangement for feeding cores (31; 31 L, 31 R; 31 L', 31 R') into the winder, in which method the cores (31 L, 31 R; 31 L', 31 R') are positioned one at time to a location for pick up to the winding stations, in which method the cores (31; 31 L, 31 R; 31 L', 31 R') for one set are moved into the winder in pairs (31 L, 31 R; 31 L', 31 R') by a core pusher (21) that pushes two adjacent cores (31 L, 31 R; 31 L', 31 R') into the winder simultaneously and **characterized in that** in the method at first two adjacent cores (31 L, 31 R) are fed into the winder by the core

pusher (21) and one core (31 L) is located in correct position for pick up to the respective winding station at one of the two winding rolls (35L), the core pusher (21) moves backwards and is reduced for moving the one not in correct position located core (31 R) and the core pusher (21) moves and locates the other core (31 R) for the respective winding station on the other (35R) of the two winding rolls, the core pusher (21) is reduced and returned between the next two cores and expanded for transfer of the next two cores (31 L', 31 R') and that in the method in case of uneven number of cores (31; 31 L, 31 R; 31 L', 31 R') needed for winding a set of partial web rolls (35L, 35R) one core is moved and located at time.

2. Method according to claim 1, **characterized in, that** in the method one core (31 L; 31 L') of a pair of two adjacent cores (31 L, 31 R; 31 L', 31 R') is located in the winder at time.
3. Method according to claim 1, **characterized in, that** in the method a pair of cores (31 L', 31 R') is moved for feeding into the winder while the previous pair of cores (31 L, 31 R) is moved into and located in the winder to correct positions for pick up to the winding stations.
4. Method according to claim 1, **characterized in, that** in the method the cores (31; 31 L, 31 R; 31 L', 31 R') for one set are transferred to the winder such that at the end of the feeding the cores (31) are in the winder for pick up to the winding stations in two adjacent rows at correct locations in respect of the winding stations.
5. Device in a winder for winding of partial webs in a multistation type winder, which comprises one or two winding rolls on which winding stations are provided for winding the partial webs around cores (31; 31 L", 31 R") to partial web rolls (35L, 35R) as set in the winding stations by a nip between the winding roll and the partial web roll being formed, which device comprises an arrangement for feeding cores (31; 31 L, 31 R; 31 L', 31 R') into the winder and for locating the cores (31 L, 31 R) in the winder to be picked up to the winding stations on the winding rolls, and the arrangement comprises a core pusher (21) for pushing one or two adjacent cores (31 L, 31 R) at time into the winder and **characterized in that** the arrangement comprises reducers (22L, 22R; 23L, 23R) adjacent to the transfer guides (24R, 24R) for reducing the core pusher (21) for pushing one core (31 R) only and for reducing the core pusher (21) to be movable in between two adjacent cores (31 L', 31 R').
6. Device according to claim 5, **characterized in, that** the arrangement comprises two transfer guides

(24L, 24R), which are located adjacent to each other such that the adjacent cores (31L, 31R; 31L', 31R') located on them are not in contact.

7. Device according to claim 6, **characterized in, that** the in arrangement one transfer guide (24L) is for a winding stations at one of the winding rolls (35L) of the winder and the other transfer guide (24R) is for a winding stations at the other (35R) of the winding rolls.
8. Device according to claim 5, **characterized in, that** the arrangement comprises a core storage (30) for cores (31) to be fed to the winder and a batching means (34) for moving the cores (31) onto the transfer guides (24L, 24R).
9. Device according to claim 5, **characterized in, that** the arrangement comprises an expander (20) for expanding the reduced core pusher (21) for pushing two cores at time.

#### Patentansprüche

1. Verfahren zum Wickeln von Teilbahnen, wobei in dem Verfahren die Teilbahnen um Kerne (31; 31 L"; 31 R") in Teilbahnrollen (35L, 35R) als Satz in Wickelstationen mittels eines Walzenspalts zwischen einer Wicklerrolle und der in einem Wickler mit mehreren Stationen, welcher eine oder zwei Wickelrollen (35L; 35R) und eine Anordnung zum Zuführen von Kernen (31; 31 L; 31 R; 31 L'; 31 R') in den Wickler aufweist, gebildeten Teilbahnrolle gewickelt werden, wobei in dem Verfahren die Kerne (31 L, 31 R; 31 L', 31 R') einer nach dem anderen zu einer Position zum Aufnehmen derselben zu den Wickelstationen positioniert werden, wobei in dem Verfahren die Kerne (31 L, 31 R; 31 L', 31 R') für einen Satz in Paaren (31 L, 31 R; 31 L', 31 R') mittels einer Kernschiebeeinrichtung (21), welche zwei benachbarte Kerne (31 L, 31 R; 31 L', 31 R') gleichzeitig in den Wickler schiebt, in dem Wickler bewegt werden, **dadurch gekennzeichnet, dass** in dem Verfahren zuerst zwei benachbarte Kerne (31 L, 31 R) mittels der Kernschiebeeinrichtung (21) in den Wickler zugeführt werden und ein Kern (31 L) in der korrekten Position zum Aufnehmen zu der entsprechenden Wickelstation an einer der beiden Wickelrollen (35L) angeordnet ist, wobei die Kernschiebeeinrichtung (21) sich rückwärts bewegt und verkürzt bzw. eingezogen wird, um den einen nicht in der korrekten Position angeordneten Kern (31 R) zu bewegen, und wobei die Kernschiebeeinrichtung (21) den anderen Kern (31 R) zu der entsprechenden Wickelstation auf der anderen (35R) der zwei Wickelrollen bewegt und anordnet, wobei die Kernschiebeeinrichtung (21) verkürzt bzw. eingezogen

- wird und zwischen die nächsten beiden Kerne zurückgeführt und für den Transport der nächsten zwei Kerne (31 L', 31 R') gefahren wird, und dass in dem Verfahren im Falle einer ungeraden Anzahl von Kernen (31; 31 L, 31 R; 31 L', 31 R'), die für das Wickeln eines Satzes von Teilbahnrollen (35L, 35R) benötigt werden, ein Kern nach dem anderen bewegt und angeordnet wird.
2. Verfahren nach Anspruch 1, **dadurch gekennzeichnet, dass** bei dem Verfahren ein Kern (31 L; 31 L') eines Paares benachbarter Kerne (31 L, 31 R; 31 L', 31 R') gleichzeitig in dem Wickler angeordnet wird.
3. Verfahren nach Anspruch 1, **dadurch gekennzeichnet, dass** in dem Verfahren ein Paar Kerne (31 L', 31 R') zum Zuführen zu dem Wickler bewegt wird, während das vorhergehende Paar Kerne (31 L, 31 R) in korrekte Positionen zum Aufnehmen zu den Wickelstationen in den Wickler bewegt und in demselben angeordnet wird.
4. Verfahren nach Anspruch 1, **dadurch gekennzeichnet, dass** in dem Verfahren die Kerne (31; 31 L, 31 R; 31 L', 31 R') für einen Satz auf eine solche Art und Weise zu dem Wickler bewegt werden, dass an dem Ende des Zuführens die Kerne (31) sich in dem Wickler zum Aufnehmen zu den Wickelstationen in zwei benachbarten Reihen an korrekten Positionen hinsichtlich der Wickelstationen befinden.
5. Vorrichtung in einem Wickler zum Wickeln von Teilbahnrollen in einem Wickler mit mehreren Stationen, welcher eine oder zwei Wickelrollen aufweist, auf denen Wickelstationen zum Wickeln der Teilbahnen um Kerne (31; 31 L', 31 R') in Teilbahnrollen (35L, 35R) als Satz in den Wickelstationen mittels eines Walzenspalts zwischen der Wickelrolle und der erzeugten Teilbahnrolle bereitgestellt sind, wobei die Vorrichtung eine Anordnung zum Zuführen von Kernen (31; 31 L, 31 R; 31 L', 31 R') in den Wickler und zum Anordnen der Kerne (31 L, 31 R) in dem Wickler aufweist, um zu den Wickelstationen auf den Wickelrollen aufgenommen zu werden, und wobei die Anordnung eine Kernschiebeeinrichtung (21) zum Schieben von einem oder mehreren benachbarten Kernen (31 L, 31 R) nacheinander in den Wickler aufweist, **dadurch gekennzeichnet, dass** die Anordnung eine Rückzugseinrichtung (22L, 22R; 23L, 23R) benachbart zu den Transportführungen (24L, 24R) zum Verkürzen bzw. Einziehen der Kernschiebeeinrichtung (21), zum Schieben von einem Kern (31) und zum Verkürzen bzw. Einziehen der Kernschiebeeinrichtung (21), um zwischen zwei benachbarten Kernen (31 L', 31 R') bewegbar zu sein, aufweist.
6. Vorrichtung nach Anspruch 5, **dadurch gekennzeichnet, dass** die Vorrichtung zwei Transportführungen (24L, 24R) aufweist, die derart benachbart zueinander angeordnet sind, dass die auf denselben angeordneten benachbarten Kerne (31 L, 31 R; 31 L', 31 R') nicht in Kontakt sind.
7. Vorrichtung nach Anspruch 6, **dadurch gekennzeichnet, dass** in der Anordnung eine Transportführung (24L) für eine Wickelstation an einer der Wickelrollen (35L) des Wicklers und die andere Transportführung (24R) für eine Wickelstation an der anderen (35R) der Wickelrollen vorgesehen ist.
8. Vorrichtung nach Anspruch 5, **dadurch gekennzeichnet, dass** die Anordnung ein Kernlager (30) für die dem Wickler zuzuführende Kerne (31) und eine Stapeleinrichtung (34) zum Bewegen der Kerne (31) auf die Transportführungen (24L, 24R) aufweist.
9. Vorrichtung nach Anspruch 5, **dadurch gekennzeichnet, dass** die Anordnung eine Ausfahreinrichtung (20) zum Ausfahren der verkürzten bzw. eingezogenen Kernschiebeeinrichtung (21) zum gleichzeitigen Schieben zweier Kerne aufweist.
- Revendications**
1. Procédé d'enroulement de nappes partielles, dans lequel procédé les nappes partielles sont enroulées autour de bobines (31 ; 31 L', 31 R") en rouleaux de nappes partielles (35L, 35R) tels que créés dans des postes d'enroulement par un interstice entre un rouleau d'enroulement et le rouleau de nappe partielle étant formé dans une enrouleuse de type multiposte qui est composée d'un ou de deux rouleaux d'enroulement (35L, 35R) et d'un système d'apport de bobines (31 ; 31 L, 31 R ; 31 L' ; 31 R') dans l'enrouleuse, procédé dans lequel les bobines (31 ; 31 L, 31 R ; 31 L' ; 31 R') sont positionnées une par une à un point de prise en charge des postes d'enroulement, dans lequel procédé les bobines (31 ; 31 L, 31 R ; 31 L' ; 31 R') d'un ensemble sont déplacées vers l'intérieur de l'enrouleuse en paires (31 ; 31 L, 31R; 31L'; 31 R') par un pousse-bobines (21) qui pousse deux bobines adjacentes (31 ; 31 L, 31 R ; 31 L' ; 31 R') dans l'enrouleuse simultanément, et **caractérisé en ce que**, dans le procédé, deux bobines adjacentes (31 L, 31 R) sont d'abord apportées dans l'enrouleuse par le pousse-bobines (21) et

- qu'une bobine (31 L) se trouve à une position correcte pour prise en charge dans le poste d'enroulement respectif au niveau d'un des deux rouleaux d'enroulement (35L), que le pousse-bobines (21) recule et est réduit pour déplacer la bobine (31 R) non placée en position correcte et que le pousse-bobines (21) déplace et positionne l'autre bobine (31 R) pour le poste d'enroulement respectif sur l'autre (35R) des deux rouleaux d'enroulement, que le pousse-bobines (21) est réduit et renvoyé entre les deux bobines suivantes et agrandi pour le transfert des deux bobines suivantes (31 L', 31 R') et que, dans le procédé, dans le cas d'un nombre impair de bobines (31 ; 31 L, 31 R ; 31 L', 31 R') nécessaire pour enrouler un ensemble de rouleaux de nappes partielles (35L, 35R), une bobine est déplacée et positionnée à la fois.
2. Procédé selon la revendication 1, **caractérisé en ce que**, dans le procédé, une bobine (31 L ; 31 L') d'une paire de deux bobines adjacentes (31 L, 31 R ; 31 L', 31 R') se trouve dans l'enrouleuse à la fois.
  3. Procédé selon la revendication 1, **caractérisé en ce que**, dans le procédé, une paire de bobines (31 L' ; 31 R') est déplacée pour être apportée dans l'enrouleuse pendant que la paire précédente de bobines (31 L, 31 R) est déplacée et placée dans l'enrouleuse à des positions correctes pour prise en charge par les postes d'enroulement.
  4. Procédé selon la revendication 1, **caractérisé en ce que**, dans le procédé, les bobines (31 ; 31L, 31R ; 31L', 31R') d'un ensemble sont transférées à l'enrouleuse de manière à ce que, à la fin de l'apport, les bobines (31) se trouvent dans l'enrouleuse pour prise en charge par les postes d'enroulement sur deux rangées adjacentes à des positions correctes par rapport aux postes d'enroulement.
  5. Dispositif situé dans une enrouleuse pour l'enroulement de nappes partielles dans une enrouleuse de type multiposte, qui comprend un ou deux rouleaux d'enroulement sur lesquels sont prévus des postes d'enroulement pour enrouler les nappes partielles autour de bobines (31 ; 31 L", 31 R") en rouleaux de nappes partielles (35L, 35R) tels que créés dans les postes d'enroulement par un interstice entre le rouleau d'enroulement et le rouleau de nappe partielle en train d'être formé, lequel dispositif comprend un système d'apport des bobines (31 ; 31 L, 31R ; 31L', 31R') dans l'enrouleuse et de positionnement des bobines (31 L, 31 R) dans l'enrouleuse pour prise en charge par les postes d'enroulement sur les rouleaux d'enroulement et le système comprend un pousse-bobines (21) pour pousser une ou deux bobines adjacentes (31 L, 31 R) à la fois dans l'enrouleuse, et **caractérisé en ce que** le système comprend des réducteurs (22L, 22R ; 23L, 23R) adjacents aux guides de transfert (24L, 24R) pour réduire le pousse-bobines (21) afin de pousser seulement une bobine (31 R) et de réduire le pousse-bobines (21) pour qu'il soit mobile entre deux bobines (31 L', 31 R') adjacentes.
  6. Dispositif selon la revendication 5, **caractérisé en ce que** le système comprend deux guides de transfert (24L, 24R) qui sont positionnés adjacents l'un à l'autre de manière à ce que les bobines adjacentes (31 L, 31 R ; 31 L', 31 R') positionnées sur ceux-ci ne soient pas en contact.
  7. Dispositif selon la revendication 6, **caractérisé en ce que**, dans le système, un guide de transfert (24L) est destiné à des postes d'enroulement au niveau de rouleaux d'enroulement (35L) de l'enrouleuse et que l'autre guide de transfert (24R) est destiné à des postes d'enroulement de l'autre (35R) rouleau d'enroulement.
  8. Dispositif selon la revendication 5, **caractérisé en ce que** le système comprend un système de stockage de bobines (30) pour des bobines (31) à apporter à l'enrouleuse et un moyen d'engrangement (34) pour déplacer les bobines (31) sur les guides de transfert (24L, 24R).
  9. Dispositif selon la revendication 5, **caractérisé en ce que** le système comprend un agrandisseur (20) pour agrandir le pousse-bobines réduit (21) afin de pousser deux bobines à la fois.

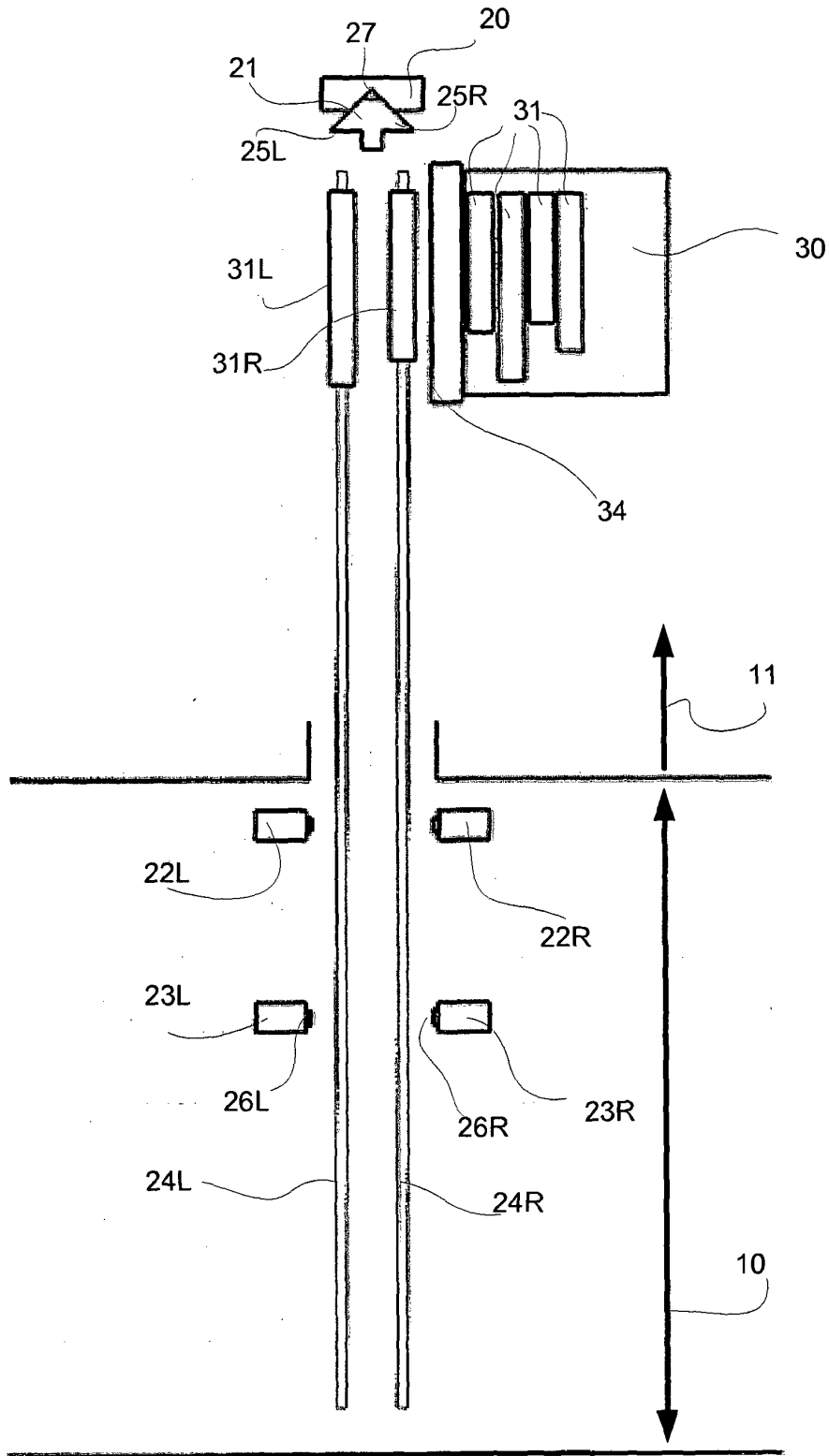

Fig. 1

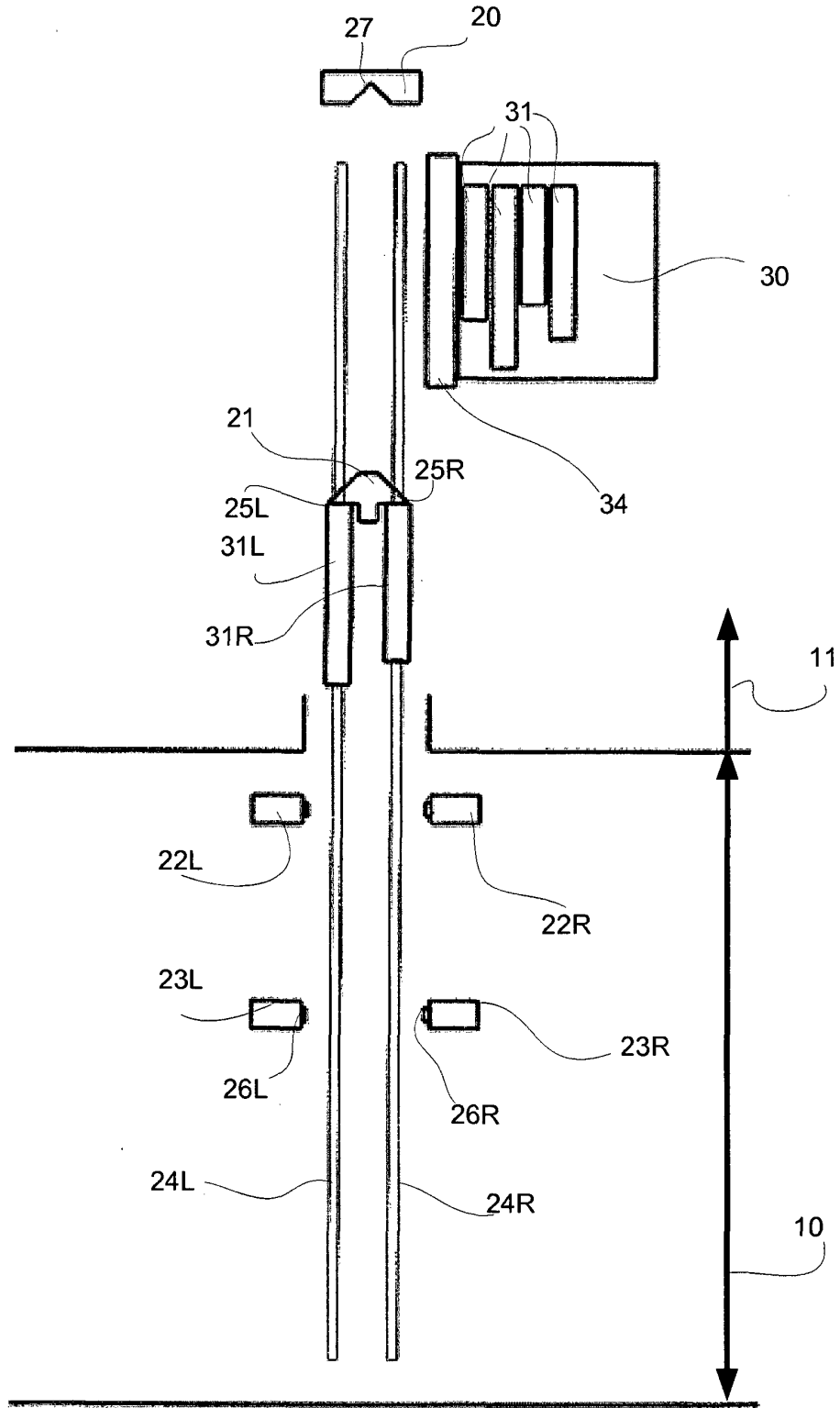

Fig. 2

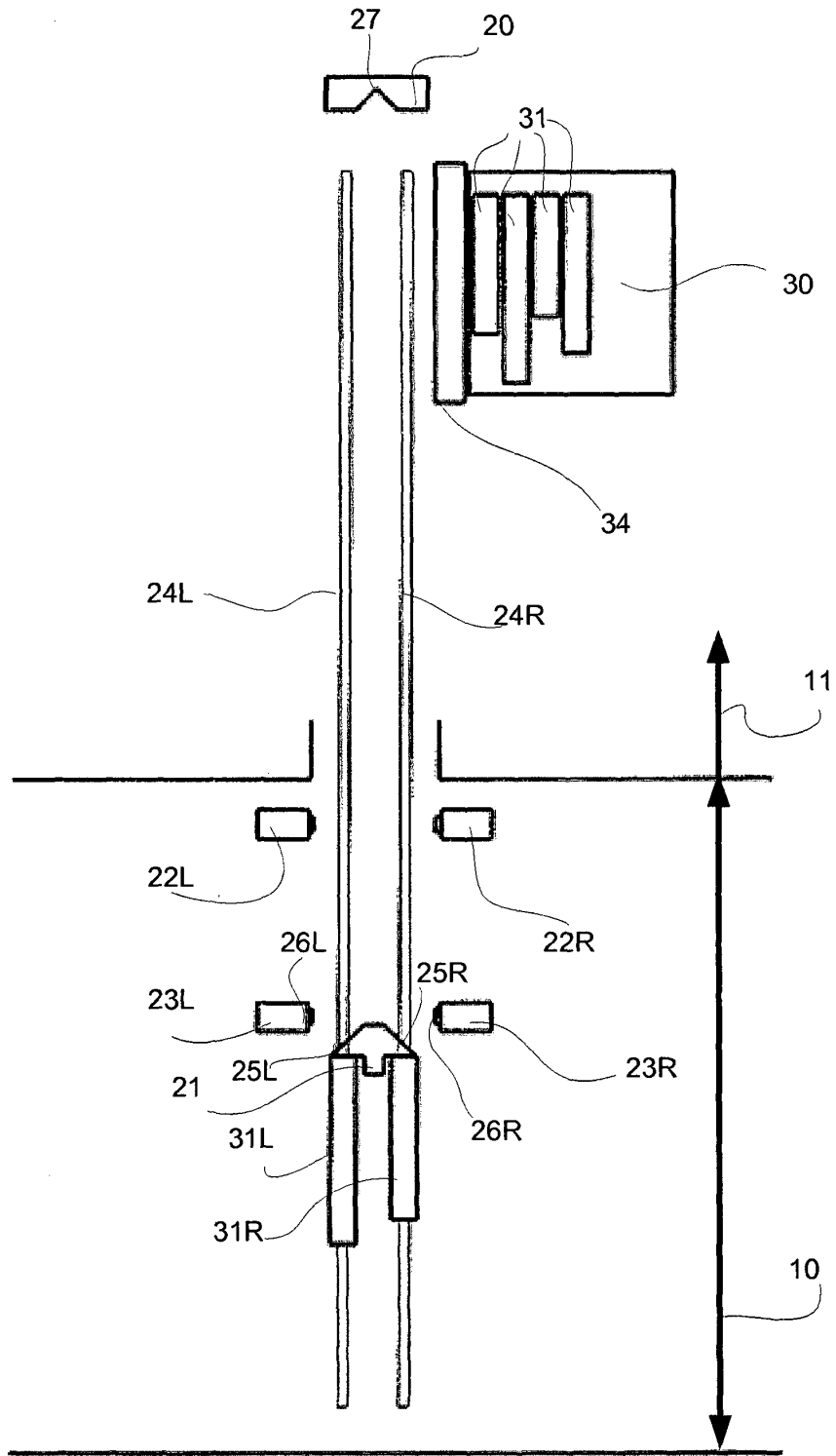

Fig. 3

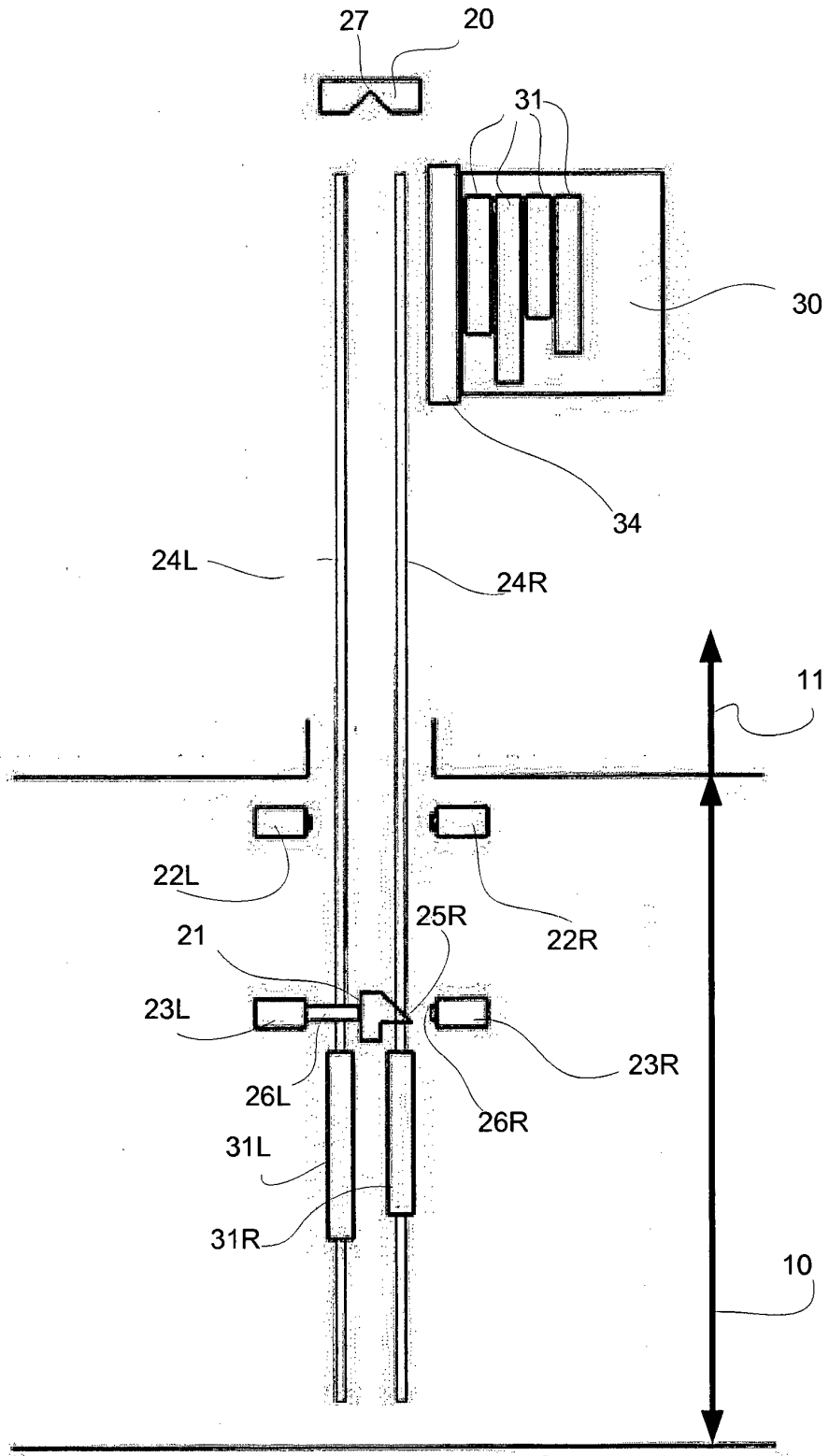

Fig. 4

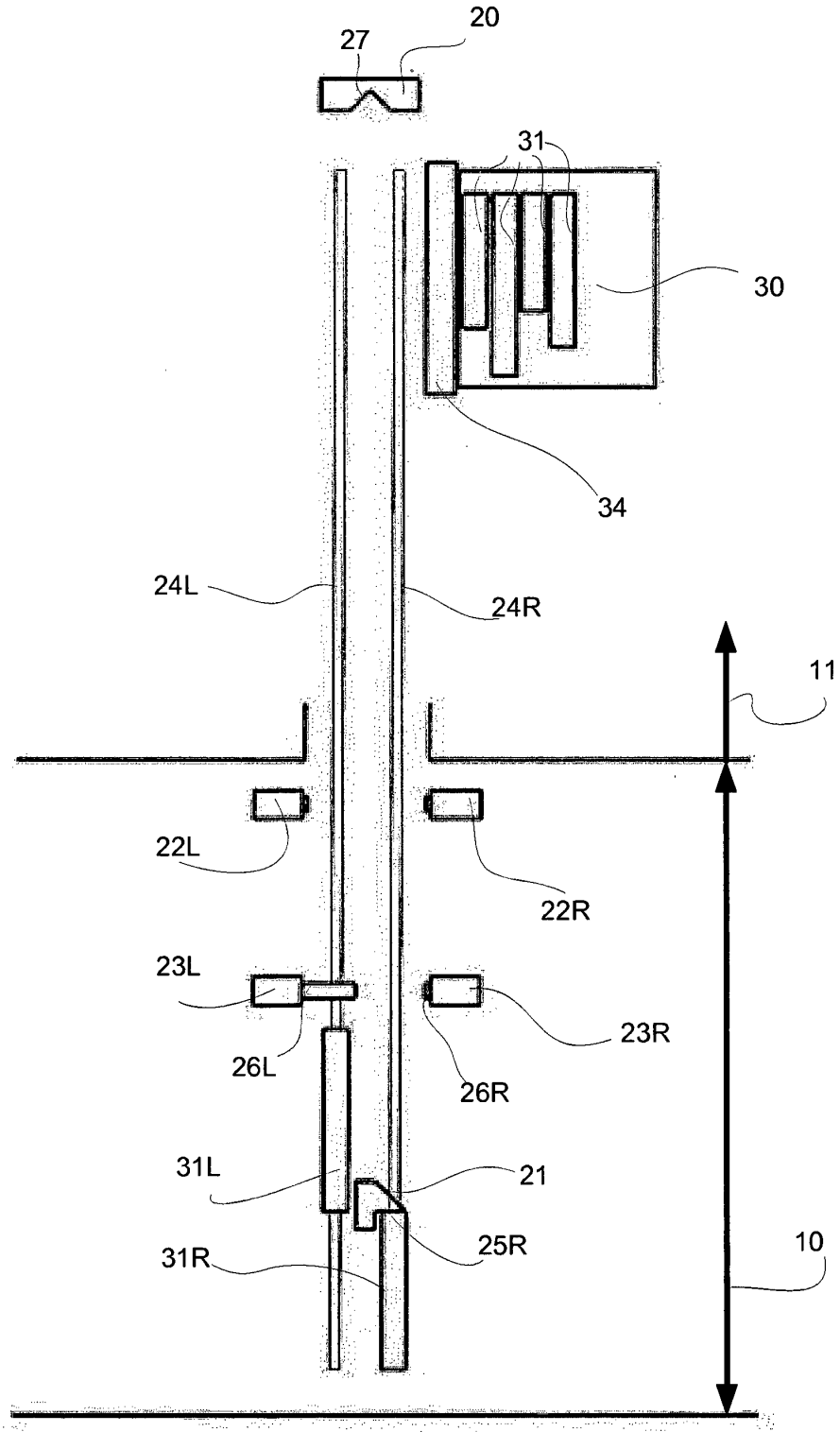

Fig. 5

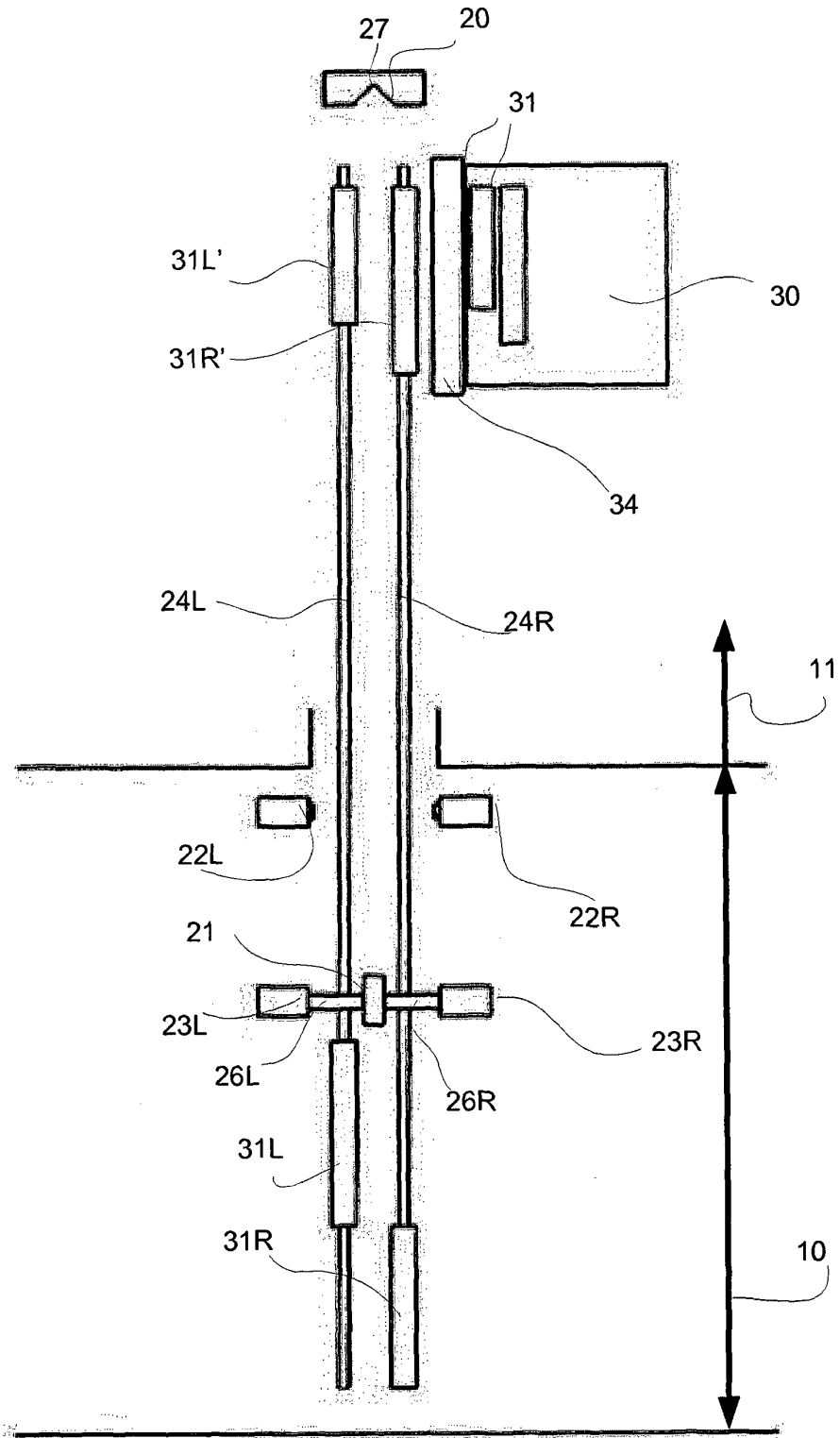

Fig. 6

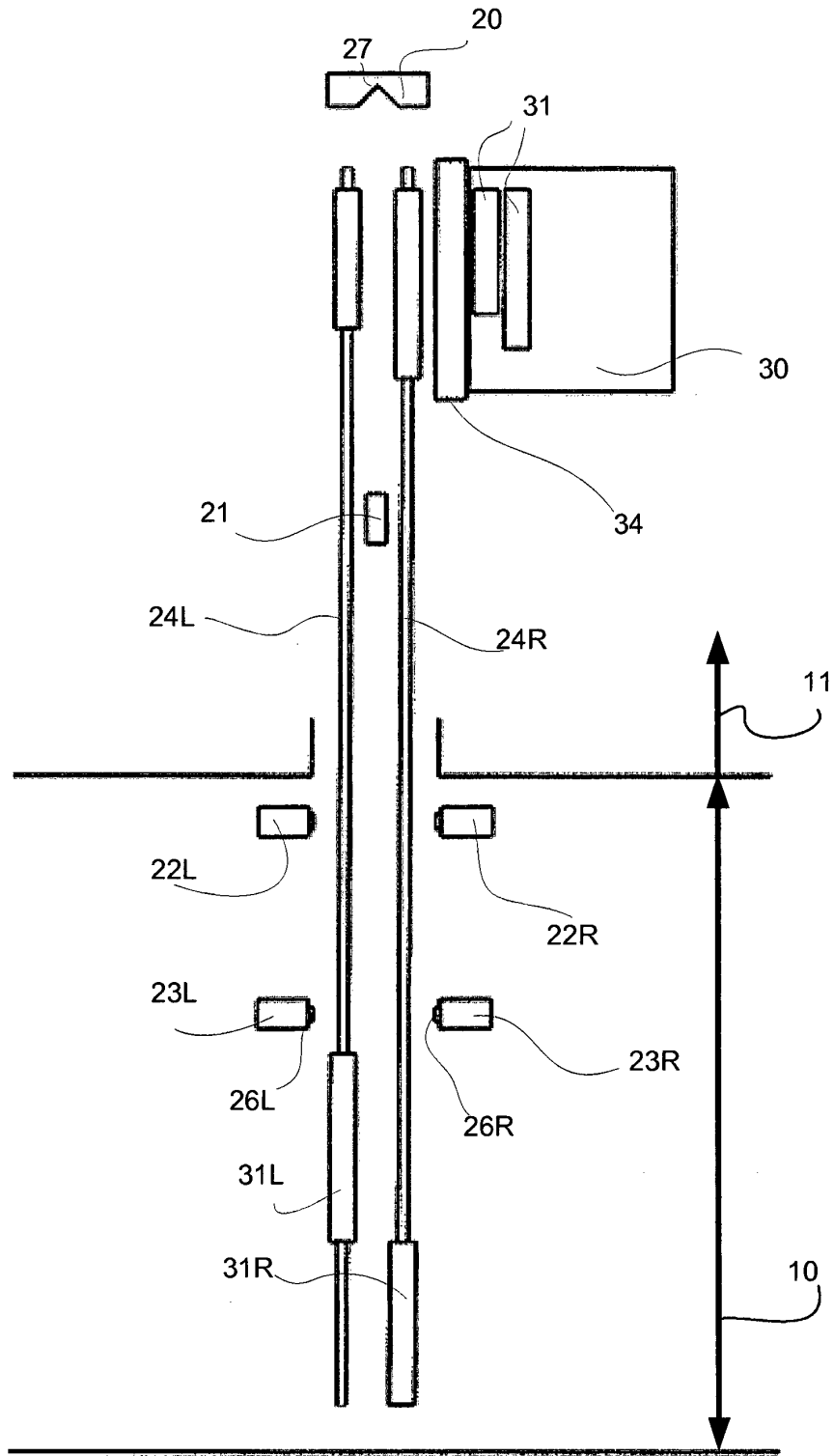

Fig. 7

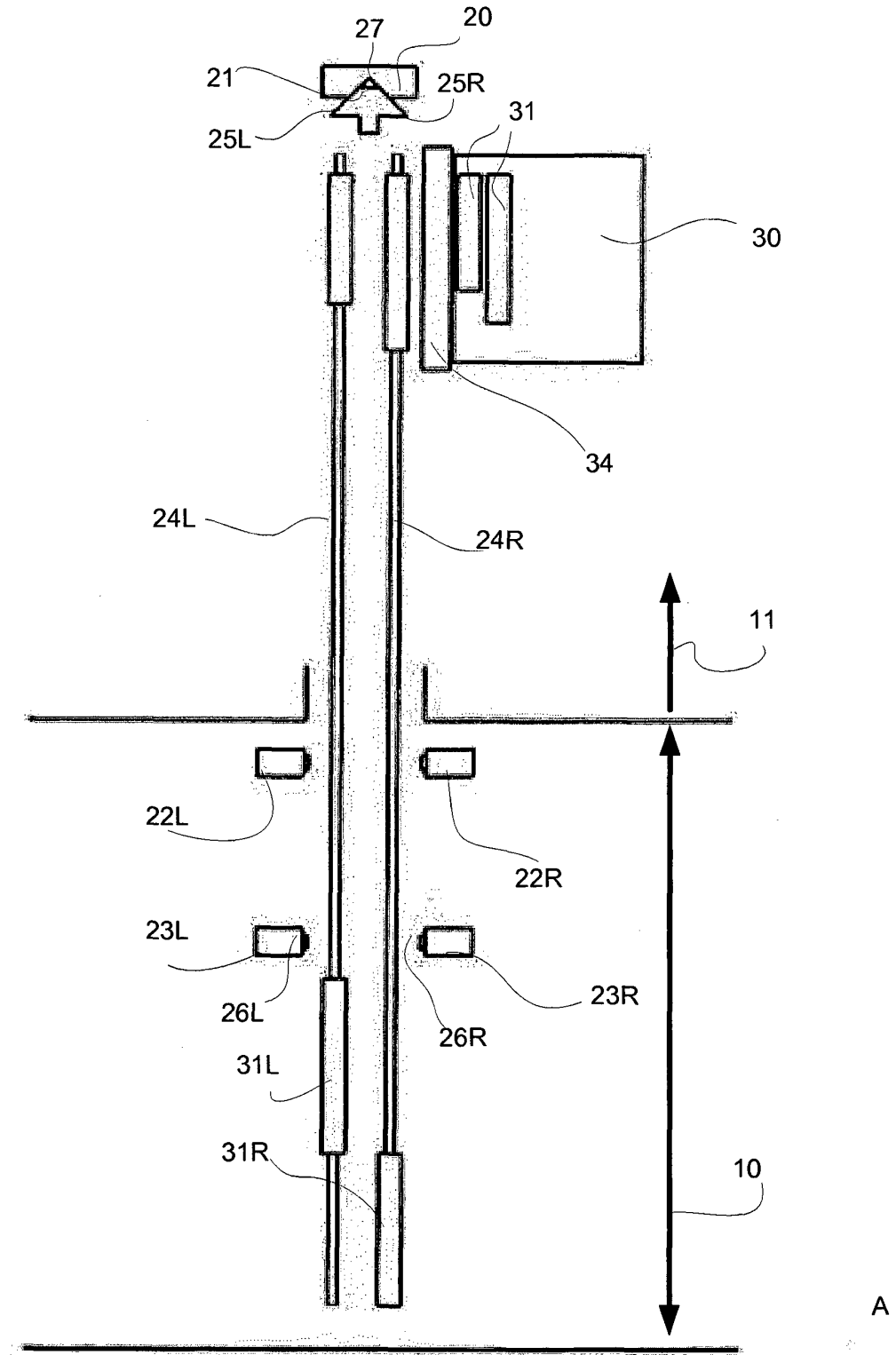

Fig. 8

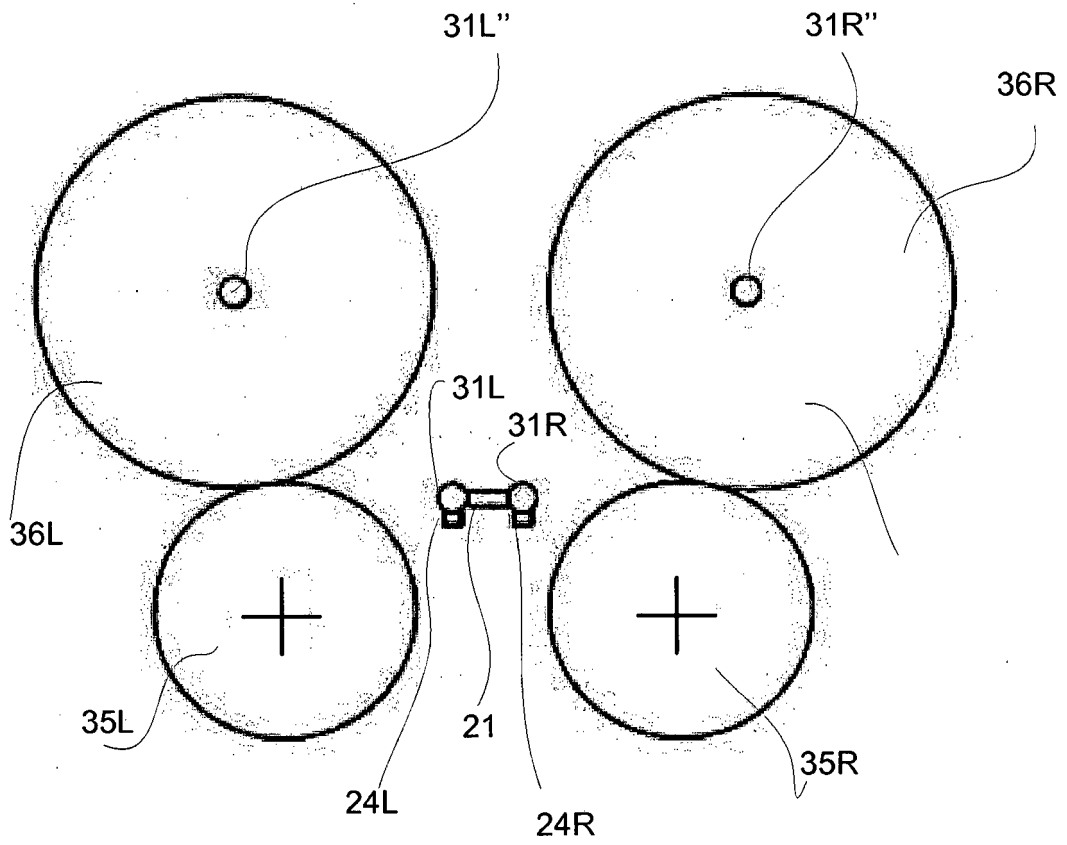

Fig. 9

**REFERENCES CITED IN THE DESCRIPTION**

*This list of references cited by the applicant is for the reader's convenience only. It does not form part of the European patent document. Even though great care has been taken in compiling the references, errors or omissions cannot be excluded and the EPO disclaims all liability in this regard.*

**Patent documents cited in the description**

- EP 0258533 A [0008]
- US 4508283 A [0009]
- GB 2136403 A [0009]