

(19)



(11)

EP 2 685 159 B1

(12)

EUROPEAN PATENT SPECIFICATION

(45) Date of publication and mention of the grant of the patent:
10.01.2018 Bulletin 2018/02

(51) Int Cl.:
F23C 3/00^(2006.01) F23D 14/64^(2006.01)

(21) Application number: **13176049.8**

(22) Date of filing: **11.07.2013**

(54) Portable gas burner and assembling method

Tragbarer Gasbrenner und Montageverfahren

Brûleur à gaz portatif et procédé de montage

(84) Designated Contracting States:
AL AT BE BG CH CY CZ DE DK EE ES FI FR GB GR HR HU IE IS IT LI LT LU LV MC MK MT NL NO PL PT RO RS SE SI SK SM TR

(30) Priority: **12.07.2012 IT MI20121215**

(43) Date of publication of application:
15.01.2014 Bulletin 2014/03

(73) Proprietor: **MCS Italy S.p.A.**
37010 Pastrengo, Verona (IT)

(72) Inventors:
• **Cecchini, Marco**
I-37010 Pastrengo, Verona (IT)
• **Giarretta, Enzo**
I-37010 Pastrengo, Verona (IT)

(74) Representative: **Leihkauf, Steffen Falk et al**
Jacobacci & Partners S.p.A.
Via Senato 8
20121 Milano (IT)

(56) References cited:
DE-A1- 19 927 013 US-A- 2 815 019
US-B2- 7 566 218

EP 2 685 159 B1

Note: Within nine months of the publication of the mention of the grant of the European patent in the European Patent Bulletin, any person may give notice to the European Patent Office of opposition to that patent, in accordance with the Implementing Regulations. Notice of opposition shall not be deemed to have been filed until the opposition fee has been paid. (Art. 99(1) European Patent Convention).

Description

[0001] It is the object of the present invention a portable gas heater, in particular a liquefied propane gas (LPG), of the type represented in Figure 10. This type of known heaters generally comprises:

- a support structure,
- a burner unit connected to the support structure and having:
 - a combustion chamber formed by a side wall, a front grid connected to a front end of the side wall to allow the outflow of hot combusted gases from the combustion chamber, and a rear wall connected to a rear portion of the side wall,
 - a supply tube for supplying the fuel gas, said supply tube having a front length extending through the rear wall to the inside of the combustion chamber and a rear length extending outside of the combustion chamber,
 - a diffuser or flame spreader member connected to an outlet port of the front length of the supply tube and shaped to prevent a reverse flow of flame in the tube,
 - a control unit for adjusting the supply of fuel gas to the burner, said control unit being connected to the support structure and having:
 - an adjustment conduit with an inlet opening connectable to a fuel gas source and a gas outlet opening connected to the outer length of the supply tube,
 - valve means arranged in the adjustment conduit and suitable to adjust the flow rate of the flow in said adjustment conduit. US 2815019 describes a portable heater according to the preamble of claim 1 and the corresponding method for assembling said portable heater according to the preamble of claim 14.

[0002] The single components of the known portable heaters are assembled and made integral by irreversible connection procedures such as weldings, metal pressing, mechanical flaring, and, in some cases, by screws or bolts engaging two or more components to be connected, respectively. Fig. 10 illustrates a portable gas heater of the prior art, in which the single components are connected together by weldings.

[0003] The known portable heaters, while being reliable and structurally resistant, have some drawbacks. The assembling requires long times and skilled labour, and the replacement of single worn or damaged components is very difficult. Furthermore, due to the different thermal dilations of the single components, the weldings have to be over-dimensioned in order to resist the thermal tensions that occur during the operation of the heater.

[0004] Therefore, the object of the present invention is to provide a portable gas heater of the type described above, as well as a manufacturing procedure of such a portable gas heater, having characteristics such as to at least in part obviate the drawbacks mentioned with reference to the prior art.

[0005] A particular object of the invention is to provide a portable gas burner having characteristics such as to simplify and make the assembling quicker without the need for skilled labour.

[0006] A further object of the invention is to provide a portable gas burner having characteristics such as to facilitate the replacement of single worn or damaged components.

[0007] These and other objects are achieved by a portable gas heater comprising:

- a support structure having a front side and a rear side opposite the front side,
- a tubular side wall connected to the support structure and having a longitudinal axis, said tubular wall defining internally a combustion chamber and having a front end facing the front side and open to allow the outflow of hot combusted gases from the combustion chamber, as well as a rear end facing the rear side,
- optionally, a protection grid connected to the front end of the side wall
- a rear wall connected to the side wall near the rear end and defining the combustion chamber towards the rear side,
- a supply tube for supplying fuel gas to the combustion chamber, said supply tube having a front length extending through the rear wall to the inside of the combustion chamber and a rear length extending outside of the combustion chamber. According to the invention, the rear length of the supply tube is connected to the support structure and a flame spreader member is connected to an outlet port of the front length of the supply tube, and at least one of the connections:
 - between the supply tube and the support structure,
 - between the flame spreader member, the supply tube, and the rear wall,
 - between the rear wall and the side wall is composed of a clearance fit.

[0008] According to a further embodiment of the invention,

- the side wall is locked to the support structure so as to prevent a translation of the side wall, with respect to the support structure, parallel to the longitudinal axis,
- the rear length of the supply tube is inserted in a tube seat of the support structure along a first connection

axis transversal to the longitudinal axis so as to prevent a translation of the supply tube, with respect to the support structure, parallel to the longitudinal axis and a rotation of the supply tube, with respect to the support structure, around an axis parallel to the longitudinal axis,

- the flame spreader member is inserted from the front side on the front length of the supply tube along a second connection axis transversal to the first connection axis and parallel to the longitudinal axis
- the front length of the supply tube and the flame spreader member are both inserted along the second connection axis in a passage opening of the rear wall,
- the front length of the supply tube abuts from the rear side against an abutment surface of the flame spreader member so as to prevent a further translation of the flame spreader member with respect to the supply tube towards the rear side,
- the rear wall abuts from the front side against a stop surface of the flame spreader member so as to prevent a further translation of the rear wall towards the rear side.

[0009] The object of the invention is further achieved by a method for assembling a portable gas heater comprising:

- a support structure having a front side and a rear side opposite the front side,
- a tubular side wall connected to the support structure and having a longitudinal axis, said tubular wall defining internally a combustion chamber and having a front end facing the front side and open to allow the outflow of hot combusted gases from the combustion chamber, as well as a rear end facing the rear side,
- optionally, a protection grid connected to the front end of the side wall
- a rear wall connected to the side wall near the rear end and defining the combustion chamber towards the rear side,
- a supply tube for supplying fuel gas to the combustion chamber, said supply tube having a front length extending through the rear wall to the inside of the combustion chamber and a rear length extending outside of the combustion chamber,
- a flame spreader member connected to an outlet port of the front length of the supply tube and shaped to prevent a reverse flow of flame in the tube. According to the invention,

said method comprises the step of carrying out at least one of the connections:

- between the supply tube and the support structure,
- between the flame spreader member, the supply tube, and the rear wall,

- between the rear wall and the side wall,

by a clearance fit.

[0010] According to a further embodiment of the invention, said method comprises the steps of:

- locking the side wall to the support structure so as to prevent a translation of the side wall, with respect to the support structure, parallel to the longitudinal axis,
- inserting the rear length of the supply tube in a tube seat of the support structure along a first connection axis transversal to the longitudinal axis so as to prevent a translation of the supply tube, with respect to the support structure, parallel to the longitudinal axis and a rotation of the supply tube, with respect to the support structure, around an axis parallel to the longitudinal axis,
- inserting the flame spreader member from the front side on the front length of the supply tube along a second connection axis transversal to the first connection axis and parallel to the longitudinal axis,
- inserting the front length of the supply tube and the flame spreader member both along the second connection axis in a passage opening of the rear wall,
- forming an abutment surface at the flame spreader member and abutting the front length of the supply tube from the rear side against said abutment surface so as to prevent a further translation of the flame spreader member with respect to the supply tube towards the rear side,
- forming a stop surface at the flame spreader member and abutting the rear wall from the front side against said stop surface so as to prevent a further translation of the rear wall towards the rear side.

[0011] By virtue of the single connections with insertion and clearance fit along the connection axes, during the assembling of the heater, a progressive reduction of the degrees of freedom is achieved, until completely stiffening the structure thereof. Thus, the need is obviated to carry out weldings or to use a high number of screws and the manufacturing times and costs are reduced. All the connections are reversible, and the replacement of single damaged or worn components is considerably facilitated.

[0012] In order to better understand the invention and appreciate the advantages thereof, some exemplary, non-limiting embodiments will be described herein below, with reference to the appended Figures, in which:

Fig. 1 is a perspective view of a portable gas heater according to an embodiment, in which a part of the housing was removed;

Fig. 2 illustrates the heater in Fig. 1 with an outer housing completely removed;

Fig. 3 is a perspective view of a detail of the heater in Fig. 1;

Fig. 4 is an exploded view of the heater in Fig. 1;
 Fig. 5 is an enlarged view of some details in Fig. 4;
 Fig. 6 shows a series of enlarged views of details of the heater according to an embodiment;
 Fig. 7 shows a side view (with a partially removed housing) of a burner according to an embodiment, and two enlarged views of details of the heater;
 Fig. 8 is a longitudinal sectional view of a portable heater according to an embodiment;
 Fig. 9 is a schematized representation of the constraints carried out during the assembling of a portable heater according to an embodiment;
 Fig. 10 shows a gas heater according to the prior art.

[0013] With reference to the figures, a portable gas heater 1 comprises a support structure 2 having a front side 3 and a rear side 4 opposite the front side 3. In accordance with an embodiment, the support structure 2 may comprise one or more resting feet 24 defining a resting plane 25 and a normal use position of the heater 1.

[0014] The portable heater 1 further comprises:

a tubular side wall 5 connected to the support structure 2 and having a longitudinal axis 6, the tubular wall 5 defining internally a combustion chamber 7 and having a front end 8 facing the front side 3 and open to allow the outflow of hot combusted gases from the combustion chamber 7, as well as a rear end 9 facing the rear side 4,
 optionally, a protection grid 10 connected to the front end 8 of the side wall 5 and a outer housing 11,
 a rear wall 12 connected to the side wall 5 near the rear end 9 and defining the combustion chamber 7 on the rear side 4,
 a supply tube 13 for supplying fuel gas to the combustion chamber 7, said supply tube 13 having a front length 14 extending through the rear wall 12 to the inside of the combustion chamber 7 and a rear length 15 extending outside of the combustion chamber,
 a flame spreader member 16 connected to an outlet port 17 of the front length 14 of the supply tube 13 and shaped to prevent a reverse flow of flame in the tube 13.

[0015] According to a first aspect of the invention, at least one of the connections:

- between the supply tube 13 and the support structure 2,
- between the flame spreader member 16, the supply tube 13, and the rear wall 12,
- between the rear wall 12 and the side wall 5

is composed of a clearance fit or an interference fit.

[0016] According to a second aspect of the invention, the side wall 5 is locked to the support structure 2 so as to prevent a translation of the side wall 5, with respect to

the support structure 2, parallel to the longitudinal axis 6, and

the rear length 15 of the supply tube 13 is inserted in a tube seat 18 of the support structure 2 along a first connection axis 19 transversal to the longitudinal axis 6 so as to prevent a translation of the supply tube 13, with respect to the support structure 2, parallel to the longitudinal axis 6 and a rotation of the supply tube 13, with respect to the support structure 2, around an axis parallel to the longitudinal axis 6, and

the flame spreader member 16 is inserted from the front side 3 on the front length 14 of the supply tube 13 along a second connection axis 20 transversal to the first connection axis 19 and parallel to the longitudinal axis 6, and the front length 14 of the supply tube 13 and the flame spreader member 16 are both inserted along the second connection axis 20 in a passage opening 21 of the rear wall 12, and

the front length 14 of the supply tube 13 abuts from the rear side 4 against an abutment surface 22 of the flame spreader member 16 so as to prevent a further translation of the flame spreader member 16 with respect to the supply tube 13 towards the rear side 4, and

the rear wall 12 abuts from the front side 3 against a stop surface 23 of the flame spreader member 16 so as to prevent a further translation of the rear wall 12 towards the rear side 4.

[0017] In accordance with a further aspect of the invention, a method for assembling the heater 1 comprises the step or steps of carrying out at least one of the connections:

- between the supply tube 13 and the support structure 2,
- between the flame spreader member 16, the supply tube 13, and the rear wall 12,
- between the rear wall 12 and the side wall 5

by a clearance fit or an interference fit.

[0018] In accordance with a further aspect of the invention, a method for assembling the heater 1 comprises the steps of:

- locking the side wall 5 to the support structure 2 so as to prevent a translation of the side wall 5, with respect to the support structure 2, parallel to the longitudinal axis 6,
- inserting the rear length 15 of the supply tube 13 in a tube seat 18 of the support structure 2 along a first connection axis 19 transversal to the longitudinal axis 6 so as to prevent a translation of the supply tube 13, with respect to the support structure 2, parallel to the longitudinal axis 6 and a rotation of the supply tube 13, with respect to the support structure 2, around an axis parallel to the longitudinal axis 6,
- inserting the flame spreader member 16 from the front side 3 on the front length 14 of the supply tube 13 along a second connection axis 20 transversal to

the first connection axis 19 and parallel to the longitudinal axis 6,

- inserting the front length 14 of the supply tube 13 and the flame spreader member 16 both along the second connection axis 20 in a passage opening 21 of the rear wall 12,
- forming an abutment surface 22 at the flame spreader member 16 and abutting the front length 14 of the supply tube 13 from the rear side 4 against said abutment surface 22 so as to prevent a further translation of the flame spreader member 16 with respect to the supply tube 13 towards the rear side 4, - forming a stop surface 23 at the flame spreader member 16 and abutting the rear wall 12 from the front side 3 against said stop surface 23 so as to prevent a further translation of the rear wall 12 towards the rear side 4.

[0019] By virtue of the single connections with insertion and clearance fit along the connection axes, during the assembling of the heater 1, a progressive reduction of the degrees of freedom is achieved, until completely stiffening the structure thereof. Thus, the need is obviated to carry out weldings or to use a high number of screws and the manufacturing times and costs are reduced. All the connections are reversible, and the replacement of single damaged or worn components is considerably facilitated.

[0020] In accordance with an embodiment, the rear wall 12 abuts from the rear side 4 against one or more projections 26 of the flame spreader member 16 so as to lock the rear wall 12 between the stop surface 23 and the projection 26 and to prevent a translation thereof with respect to the flame spreader member 16 in both directions along the second connection axis 20.

[0021] In accordance with a further embodiment, the rear wall 12 is inserted in the rear end 9 of the side wall 5 and abuts from the rear side 4 against a stop surface 27 of the side wall 5 so as to prevent a further translation of the rear wall 12 with respect to the side wall 5 towards the front side 3.

[0022] Advantageously, the rear wall 12 is connected to the side wall 5 by a geometrical coupling preventing a relative rotation thereof around an axis parallel to the longitudinal axis 6.

[0023] In accordance with a preferred embodiment, the side wall 5 comprises a rigid metal sheet (e.g., in steel) substantially cylindrical or frusto-conical, developing concentrically around the longitudinal axis 6. A rear edge 9 of the side wall forms one or more, preferably four, (preferably trapezoidal) grooves 28 or cavities open towards the rear side 4 and suitable to receive coupling portions 29 of the rear wall 12. The grooves 28 or cavities are preferably formed in diametrically opposite positions, or with a constant angular pitch along the perimeter of the side wall 12.

[0024] The rear wall 12 may comprise a rigid metal sheet (in steel) in the shape of a circular disc having an outer diameter less than an inner diameter of the rear

end 9 of the side wall 5. The disc-shaped sheet defines the above-mentioned passage opening 21 receiving the supply tube 13 and the flame spreader member 16. The rear wall 12 may further comprise a plurality of suction openings for suctioning oxidizing air into the combustion chamber 7.

[0025] In accordance with an embodiment, the rear wall 12 comprises a reinforcing and coupling frame 30 that may be formed in a single piece with the disc-shaped metal sheet, for example, by press forming, or manufactured separately and subsequently connected thereto. The frame 30 forms a reinforcing ring around the passage opening and a plurality of (preferably four) ribs extending from the reinforcing ring radially outwardly and having free ends projecting beyond the outer perimeter of the disc-shaped sheet and form the coupling portions 29.

The width of the coupling portions 29 may be less than or equal to the width of the bottom (stop surface 27) of the grooves 28 or cavities (for example, of the lesser base in the case of trapezoidal grooves) of the side wall 5, so as to ensure an anti-rotation coupling with reduced clearances.

[0026] In accordance with a further embodiment, the rear wall 12, preferably the reinforcing ring of the frame 30, forms a slit 31 near the passage opening 21 and an enlargement screw 32 having a diameter larger than the minimum width of the slit 31 is screwed therein to deform the edge of the passage opening 21 radially inwardly and thereby creating an interference coupling between the rear wall 12 and the supply tube 13. Such interference coupling is particularly useful to ensure a proper mutual positioning of the two components in the assembling step.

[0027] The side wall 5 may be locked to the support structure 2 by a screw connection (Figure 2, screw 33) or, alternatively, by a shape connection.

[0028] The insertion of the rear length 15 of the supply tube 13 into the tube seat 18 of the support structure 2 preferably implement an interference fit and, still more preferably, free from additional weldings or connection members (e. g., screws).

[0029] Advantageously, the first connection axis 19 substantially perpendicular to the longitudinal axis 6 of the side wall 5, for example, such first connection axis 19 may be perpendicular with respect to the resting plane 25 of the support structure 2.

[0030] In the preferred embodiment (Figs. 4, 7, 8), the tube seat 18 comprises a tubular portion substantially rectilinear and oriented according to such first connection axis 19. The tube seat 18 may have an inner shape substantially complementary to the outer shape of a free end (inlet end) of the rear length 15 of the supply tube 13, so as to allow the insertion with interference of the latter. The tube seat 18 may further form an abutment shoulder 42 forming a sure reference for the positioning (insertion depth) of the supply tube 13 in the tube seat 18.

[0031] Similarly, the insertion of the flame spreader member 16 on the front length 14 of the supply tube 13

also implements a clearance fit and, preferably, free from additional weldings or connection members (e.g., screws). Advantageously, the second connection axis 20 is concentric with the longitudinal axis 6, for example, such second connection axis 20 may be substantially parallel with respect to the resting plane 25 and horizontal when the heater 1 is in the use position.

[0032] In a preferred embodiment (Figure 3), the flame spreader member 16 comprises a front plate 34 facing the front side 3 and a plurality of rear wings 35 extending from the front plate 34 towards the rear side 4 and defining a rear seat receiving, by fitting, the outlet port 17 of the supply tube 13.

In an embodiment, the rear wings 35 may elastically deflect outwardly to exert an elastic force onto the supply tube 13 such as to elastically hold it into the rear seat. The outlet port 17 of the supply tube 13 and the rear seat of the flame spreader member 16 are aligned and oriented according to the second connection axis 20. The same rear wings 35 may form a shoulder, for example, a step, which forms the above-mentioned abutment surface 22 against which the free edge of the outlet port 17 of the supply tube 13 abuts.

[0033] The flame spreader member 16 may further form one or more, preferably two, stop wings 36 extending from the front plate 34 towards the rear side 4 and possibly having a length larger than the length of the rear wings 35. The free ends of the stop wings 36 are bent radially outwardly (with respect to the rear seat of the flame spreader member and the second connection axis) and form the above-mentioned stop surface 23 against which the rear wall 12 abuts. Advantageously, the stop wings 36 may elastically deflect in a direction radial to the second connection axis 20 and exert an elastic preload (in a radially outer direction) on the rear wall 12 to elastically hold it in place.

[0034] In accordance with a further embodiment, the stop wings 36 form, near the bent free ends, one or more (preferably two) projections 26 extending in a direction transversal to the second connection axis 20 and, possibly, transversal to the extension direction of the bent free ends. These projections 26 are suitable to abut from the front side 3 against the rear wall 12 so that the rear wall 12 is locked between the projections 26 and the bent ends, without no possibility to translate with respect to the flame spreader member 16 along the second connection axis 20.

[0035] The supply tube 13 is a rigid metal tube (for example, in steel) the front 14 and rear 15 lengths thereof define therebetween an angle of preferably 90°.

[0036] The heater 1 may further comprise a control unit 37 for adjusting the supply of fuel gas to the supply tube. Such control unit 37 includes an adjustment conduit 38 with an inlet opening 39 connectable to a fuel gas source and an outlet opening 40 in communication with the outer length 15 of the supply tube 13, as well as valve means 41 arranged in the adjustment conduit 38 and suitable to adjust the flow rate of the flow in said adjustment conduit

38.

[0037] It shall be apparent that, to the portable gas heater and the assembling method according to the present invention, those of ordinary skill in the art, with the aim of meeting contingent, specific needs, will be able to make further modifications and variations, all of which are in any case contained in the protection scope of the invention, as defined by the following claims.

Claims

1. A portable gas heater (1), comprising:

- a support structure (2) having a front side (3) and a rear side (4) opposite the front side (3),
- a tubular side wall (5) connected to the support structure (2) and having a longitudinal axis (6), the tubular wall (5) defining internally a combustion chamber (7) and having a front end (8) open and facing the front side (3) as well as a rear end (9) facing the rear side (4),
- a rear wall (12) connected to the side wall (5) near the rear end (9) and defining the combustion chamber (7) on the rear side (4),
- a supply tube (13) for supplying fuel gas to the combustion chamber (7), said supply tube (13) having a front length (14) extending through the rear wall (12) to the inside of the combustion chamber (7) and a rear length (15) extending outside of the combustion chamber,

characterized in that:

- the rear length (15) of the supply tube (13) is connected to the support structure (2) and a flame spreader member (16) is connected to an outlet port (16) of the front length (14) of the supply tube (13),

and in that at least one of the connections:

- between the supply tube (13) and the support structure (2),
- between the flame spreader member (16), the supply tube (13) and the rear wall (12),
- between the rear wall (12) and the side wall (5) is a clearance fit.

2. A portable gas heater (1) according to claim 1, wherein:

- the side wall (5) is locked to the support structure (2) so as to prevent a translation of the side wall (5), with respect to the support structure (2), parallel to the longitudinal axis (6), and
- the rear length (15) of the supply tube (13) is inserted in a tube seat (18) of the support struc-

- ture (2) along a first connection axis (19) transversal to the longitudinal axis (6) so as to prevent a translation of the supply tube (13), with respect to the support structure (2), parallel to the longitudinal axis (6) and a rotation of the supply tube (13), with respect to the support structure (2), around an axis parallel to the longitudinal axis (6), and
- the flame spreader member (16) is inserted from the front side (3) on the front length (14) of the supply tube (13) along a second connection axis (20) transversal to the first connection axis (19) and parallel to the longitudinal axis (6), and
 - the front length (14) of the supply tube (13) and the flame spreader member (16) are both inserted along the second connection axis (20) in a passage opening (21) of the rear wall (12), and
 - the front length (14) of the supply tube (13) abuts from the rear side (4) against an abutment surface (22) of the flame spreader member (16) so as to prevent a translation of the flame spreader member (16) with respect to the supply tube (13) towards the rear side (4), and
 - the rear wall (12) abuts from the front side (3) against a stop surface (23) of the flame spreader member (16) so as to prevent a translation of the rear wall (12) with respect to the flame spreader member (16) towards the rear side (4).
3. The heater (1) according to claim 2, wherein the rear wall (12) abuts from the rear side (4) against one or more projections (26) of the flame spreader member (16) so as to lock the rear wall (12) between the stop surface (23) and the projection (26) and to prevent a translation thereof with respect to the flame spreader member (16) in both directions along the second connection axis (20).
 4. The heater (1) according to claim 2 or 3, wherein the rear wall (12) is connected to the side wall (5) by a geometrical coupling preventing a relative rotation thereof around an axis parallel to the longitudinal axis (6).
 5. The heater (1) according to one of claims 2 to 4, wherein a rear edge (9) of the side wall forms one or more grooves (28) open towards the rear side (4) receiving coupling portions (29) of the rear wall (12).
 6. The heater (1) according to the preceding claim, wherein the rear wall (12) comprises:
 - a circular disc-shaped metal sheet having an outer diameter lesser than an inner diameter of the rear end (9) of the side wall (5),
 - a reinforcing frame (30) connected to the disc-shaped sheet and forming a reinforcing ring around the passage opening (21) and a plurality
- of ribs extending from the reinforcing ring radially outwardly and having free ends projecting beyond the outer perimeter of the disc-shaped sheet and forming the coupling portions (29).
7. The heater (1) according to one of claims 2 to 6, wherein the rear wall (12) forms a slit (31) near the passage opening (21) and an enlargement screw (32) having a diameter larger than the minimum width of the slit (31) is screwed in said slit to deform an edge of the passage opening (21) radially inwardly.
 8. The heater (1) according to one of claims 2 to 7, wherein the side wall (5) is locked to the support structure (2) by a screw connection.
 9. The heater (1) according to one of claims 2 to 8, wherein the insertion of the rear length (15) of the supply tube (13) into the tube seat (18) implements a fit without additional weldings and connection members.
 10. The heater (1) according to one of claims 2 to 9, wherein the first connection axis (19) is substantially perpendicular to the longitudinal axis (6).
 11. The heater (1) according to one of claims 2 to 10, wherein the insertion of the flame spreader member (16) on the front length (14) of the supply tube (13) implements a clearance fit free from additional weldings or connection members.
 12. The heater (1) according to one of claims 2 to 11, wherein the flame spreader member (16) comprises:
 - a front plate (34) facing the front side (3),
 - a plurality of rear wings (35) extending from the front plate (34) towards the rear side (4) and defining a rear seat receiving, by fitting, the outlet port (17) of the supply tube (13),
 - one or more stop wings (36) extending from the front plate (34) towards the rear side (4) and having free ends bent radially outwardly and forming the stop surface (23).
 13. The heater (1) according to claim 12, wherein:
 - the rear wings (35) may deflect elastically outwardly and exert an elastic force on the supply tube (13) to elastically hold it into the rear seat,
 - the rear wings (35) form a shoulder that forms the abutment surface (22),
 - the stop wings (36) may deflect elastically and exert an elastic pre-load onto the rear wall (12) to elastically hold it in place.
 14. A method for assembling a portable gas heater (1),

comprising:

- a support structure (2) having a front side (3) and a rear side (4) opposite the front side (3),
- a tubular side wall (5) connected to the support structure (2) and having a longitudinal axis (6), the tubular wall (5) defining internally a combustion chamber (7) and having a front end (8) open and facing the front side (3) as well as a rear end (9) facing the rear side (4),
- a rear wall (12) connected to the side wall (5) near the rear end (9) and defining the combustion chamber (7) on the rear side (4),
- a supply tube (13) for supplying fuel gas to the combustion chamber (7), said supply tube (13) having a front length (14) extending through the rear wall (12) to the inside of the combustion chamber (7) and a rear length (15) extending outside of the combustion chamber and connected to the support structure (2),
- a flame spreader member (16) connected to an outlet port (16) of the front length (14) of the supply tube (13),

characterized in that said method comprising the step or steps of carrying out at least one of the connections:

- between the supply tube (13) and the support structure (2),
- between the flame spreader member (16), the supply tube (13), and the rear wall (12),
- between the rear wall (12) and the side wall (5)

by a clearance fit or an interference fit.

15. The method of claim 14, comprising the steps of:

- locking the side wall (5) to the support structure (2) so as to prevent a translation of the side wall (5), with respect to the support structure (2), parallel to the longitudinal axis (6),
- inserting the rear length (15) of the supply tube (13) in a tube seat (18) of the support structure (2) along a first connection axis (19) transversal to the longitudinal axis (6) so as to prevent a translation of the supply tube (13), with respect to the support structure (2), parallel to the longitudinal axis (6) and a rotation of the supply tube (13), with respect to the support structure (2), around an axis parallel to the longitudinal axis (6),
- inserting the flame spreader member (16) from the front side (3) on the front length (14) of the supply tube (13) along a second connection axis (20) transversal to the first connection axis (19) and parallel to the longitudinal axis (6),
- inserting the front length (14) of the supply tube

- (13) and the flame spreader member (16) both along the second connection axis (20) in a passage opening (21) of the rear wall 12,
- forming an abutment surface (22) at the flame spreader member (16) and abutting the front length (14) of the supply tube (13) from the rear side (4) against said abutment surface (22) so as to prevent a further translation of the flame spreader member (16) with respect to the supply tube (13) towards the rear side (4),
- forming a stop surface (23) at the flame spreader member (16) and abutting the rear wall (12) from the front side (3) against said stop surface (23) so as to prevent a further translation of the rear wall (12) towards the rear side (4).

Patentansprüche

1. Tragbarer Gasheizer (1), umfassend:

- eine Tragestruktur (2), welche eine vordere Seite (3) und eine hintere Seite (4) der vorderen Seite (3) gegenüber aufweist,
- eine rohrförmige Seitenwand (5), welche mit der Tragestruktur (2) verbunden ist und eine longitudinale Achse (6) aufweist, wobei die rohrförmige Wand (5) intern eine Verbrennungskammer (7) definiert und ein vorderes Ende (8), welches offen und zu der vorderen Seite (3) weisend ist, sowie ein hinteres Ende (9) aufweist, welches zu der hinteren Seite (4) weist,
- eine hintere Wand (12), welche mit der Seitenwand (5) nahe dem hinteren Ende (9) verbunden ist und die Brennkammer (7) an der hinteren Seite (4) definiert,
- eine Zufuhrleitung (13) zum Zuführen von Brennstoffgas zu der Brennkammer (7), wobei die Zufuhrleitung (13) eine vordere Länge (14), welche sich durch die hintere Wand (12) zum Inneren der Brennkammer (7) erstreckt, sowie eine hintere Länge (15) aufweist, welche sich außerhalb der Brennkammer erstreckt,

dadurch gekennzeichnet, dass:

- die hintere Länge (15) der Zufuhrleitung (13) mit der Tragestruktur (2) verbunden ist, und ein Flammenspreiz-Element (16) mit einem Auslassanschluss (16) der vorderen Länge (14) der Zufuhrleitung (13) verbunden ist,

und dadurch, dass wenigstens eine der Verbindungen:

- zwischen der Zufuhrleitung (13) und der Tragestruktur (2),
- zwischen dem Flammenspreiz-Element (16),

der Zufuhrleitung (13) und der hinteren Wand (12),
- zwischen der hinteren Wand (12) und der Seitenwand (5) eine Spielpassung ist.

2. Tragbarer Gasheizer (1) nach Anspruch 1, wobei:

- die Seitenwand (5) an der Tragestruktur (2) verriegelt ist, um so eine Verlagerung der Seitenwand (5) bezüglich der Tragestruktur (2) parallel zu der longitudinalen Achse (6) zu verhindern, und

- die hintere Länge (15) der Zufuhrleitung (13) in einen Leitungssitz (18) der Tragestruktur (2) entlang einer ersten Verbindungsachse (19) transversal zu der longitudinalen Achse (6) eingesetzt ist, um eine Verlagerung der Zufuhrleitung (13) bezüglich der Tragestruktur (2) parallel zu der longitudinalen Achse (6) und eine Rotation der Zufuhrleitung (13) bezüglich der Tragestruktur (2) um eine Achse parallel zu der longitudinalen Achse (6) zu verhindern, und

- das Flammenspreiz-Element (16) von der vorderen Seite an der vorderen Länge (14) der Zufuhrleitung (13) entlang einer zweiten Verbindungsachse (20) transversal zu der ersten Verbindungsachse (19) und parallel zu der longitudinalen Achse (6) eingesetzt ist, und

- die vordere Länge (14) der Zufuhrleitung (13) und das Flammenspreiz-Element (16) beide entlang der zweiten Verbindungsachse (20) in eine Durchgangsöffnung (21) der hinteren Wand (12) eingesetzt sind, und

- die vordere Länge (14) der Zufuhrleitung (13) von der hinteren Seite (4) gegen eine Anlagefläche (22) des Flammenspreiz-Elements (16) anliegt, um so eine Verlagerung des Flammenspreiz-Elements (16) bezüglich der Zufuhrleitung (13) in Richtung der hinteren Seite (4) zu verhindern, und

- die hintere Wand (12) von der vorderen Seite (3) gegen eine Stoppfläche (23) des Flammenspreiz-Elements (16) anliegt, um so eine Verlagerung der hinteren Wand (12) bezüglich dem Flammenspreiz-Element (16) in Richtung der hinteren Seite (4) zu verhindern.

3. Heizer (1) nach Anspruch 2, wobei die hintere Wand (12) von der hinteren Seite (4) gegen einen oder mehrere Vorsprünge (26) des Flammenspreiz-Elements (16) anliegt, um so die hintere Wand (12) zwischen der Stoppfläche (23) und dem Vorsprung (26) zu verriegeln und eine Verlagerung davon bezüglich dem Flammenspreiz-Element (16) in beide Richtungen entlang der zweiten Verbindungsachse (20) zu verhindern.

4. Heizer (1) nach Anspruch 2 oder 3, wobei die hintere

Wand (12) mit der Seitenwand (5) durch eine geometrische Kopplung verbunden ist, welche eine relative Rotation davon um eine Achse parallel zu der longitudinalen Achse (6) verhindert.

5

5. Heizer (1) nach einem der Ansprüche 2 bis 4, wobei ein hinterer Rand (9) der Seitenwand eine oder mehrere Nuten (28) bildet, welche in Richtung der hinteren Seite (4) offen sind, wobei Kopplungsabschnitte (29) der hinteren Wand (12) aufgenommen sind.

10

6. Heizer (1) nach dem vorhergehenden Anspruch, wobei die hintere Wand (12) umfasst:

- ein kreisscheibenförmiges Metallblech, welches einen Außendurchmesser aufweist, welcher kleiner als ein Innendurchmesser des hinteren Endes (9) der Seitenwand (5) ist,

- einen Verstärkungsrahmen (30), welcher mit dem scheibenförmigen Blech verbunden ist und einen Verstärkungsring um die Durchgangsöffnung (21) bildet, und wobei sich eine Mehrzahl von Rippen von dem Verstärkungsring radial nach außen erstrecken und freie Enden aufweisen, welche über den Außenumfang des scheibenförmigen Blechs überstehen und die Kopplungsabschnitte (29) bilden.

15

20

25

7. Heizer (1) nach einem der Ansprüche 2 bis 6, wobei die hintere Wand (12) einen Schlitz (31) nahe der Durchgangsöffnung (21) bildet und eine Vergrößerungsschraube (32), welche einen Durchmesser aufweist, welcher größer als die minimale Breite des Schlitzes (31) ist, in den Schlitz geschraubt ist, um einen Rand der Durchgangsöffnung (21) radial nach innen zu deformieren.

30

35

8. Heizer (1) nach einem der Ansprüche 2 bis 7, wobei die Seitenwand (5) durch eine Schraubverbindung an der Tragestruktur (2) verriegelt ist.

40

9. Heizer (1) nach einem der Ansprüche 2 bis 8, wobei das Einsetzen der hinteren Länge (15) der Zufuhrleitung (13) in den Leitungssitz (18) eine Passung ohne zusätzliche Schweißungen und Verbindungselemente implementiert.

45

10. Heizer (1) nach einem der Ansprüche 2 bis 9, wobei die erste Verbindungsachse (19) im Wesentlichen senkrecht zu der longitudinalen Achse (6) ist.

50

11. Heizer (1) nach einem der Ansprüche 2 bis 10, wobei das Einsetzen des Flammenspreiz-Elements (16) an der vorderen Länge (14) der Zufuhrleitung (13) eine Spielpassung implementiert, welche frei von zusätzlichen Schweißungen oder Verbindungselementen ist.

55

12. Heizer (1) nach einem der Ansprüche 2 bis 11, wobei das Flammenspreiz-Element (16) umfasst:

- eine vordere Platte (34), welche zu der vorderen Seite (3) weist, 5
- eine Mehrzahl von hinteren Flügeln (35), welche sich von der vorderen Platte (34) in Richtung der hinteren Seite (4) erstrecken und einen hinteren Sitz definieren, welcher durch Einpassen den Auslassanschluss (17) der Zufuhrleitung (13) aufnimmt, 10
- einen oder mehrere Stoppflügel (36), welche/r sich von der vorderen Platte (34) in Richtung der hinteren Seite (4) erstreckt/erstrecken und freie Enden aufweist/aufweisen, welche sich radial nach außen biegen und die Stoppfläche (23) bilden. 15

13. Heizer (1) nach Anspruch 12, wobei:

- die hinteren Flügel (35) elastisch nach außen abgelenkt werden können und eine elastische Kraft auf die Zufuhrleitung (13) ausüben können, um diese in dem hinteren Sitz elastisch zu halten, 20
- die hinteren Flügel (35) eine Schulter bilden, welche die Anlagefläche (22) bildet, 25
- die Stoppflügel (36) elastisch abgelenkt werden können und eine elastische Vorbelastung auf die hintere Wand (12) ausüben können, um diese elastisch an ihrem Platz zu halten. 30

14. Verfahren zum Herstellen eines tragbaren Gasheizers (1), umfassend:

- eine Tragestruktur (2), welche eine vordere Seite (3) und eine hintere Seite (4) der vorderen Seite (3) gegenüber aufweist, 35
- eine rohrförmige Seitenwand (5), welche mit der Tragestruktur (2) verbunden ist und eine longitudinale Achse (6) aufweist, wobei die rohrförmige Wand (5) intern eine Verbrennungskammer (7) definiert und ein vorderes Ende (8), welches offen und zu der vorderen Seite (3) weisend ist, sowie ein hinteres Ende (9) aufweist, welches zu der hinteren Seite (4) weist, 40
- eine hintere Wand (12), welche mit der Seitenwand (5) nahe dem hinteren Ende (9) verbunden ist und die Brennkammer (7) an der hinteren Seite (4) definiert, 45
- eine Zufuhrleitung (13) zum Zuführen von Brennstoffgas zu der Brennkammer (7), wobei die Zufuhrleitung (13) eine vordere Länge (14), welche sich durch die hintere Wand (12) zum Inneren der Brennkammer (7) erstreckt, sowie eine hintere Länge (15) aufweist, welche sich außerhalb der Brennkammer erstreckt und mit der Tragestruktur (2) verbunden ist, 50

- ein Flammenspreiz-Element (16), welches mit einem Auslassanschluss (16) der vorderen Länge (14) der Zufuhrleitung (13) verbunden ist,

dadurch gekennzeichnet, dass das Verfahren den Schritt oder die Schritte umfasst, der/die wenigstens eine der Verbindungen:

- zwischen der Zufuhrleitung (13) und der Tragestruktur (2),
- zwischen dem Flammenspreiz-Element (16), der Zufuhrleitung (13) und der hinteren Wand (12),
- zwischen der hinteren Wand (12) und der Seitenwand (5) durch eine Spielpassung oder eine Presspassung herstellt.

15. Verfahren nach Anspruch 14, umfassend die Schritte:

- Verriegeln der Seitenwand (5) an der Tragestruktur (2), um eine Verlagerung der Seitenwand (5) bezüglich der Tragestruktur (2) parallel zu der longitudinalen Achse (6) zu verhindern, 20
- Einsetzen der hinteren Länge (15) der Zufuhrleitung (13) in einen Leitungssitz (18) der Tragestruktur (2) entlang einer ersten Verbindungsachse (19) transversal zu der longitudinalen Achse (6), um so eine Verlagerung der Zufuhrleitung (13) bezüglich der Tragestruktur (2) parallel zu der longitudinalen Achse (6) und eine Rotation der Zufuhrleitung (13) bezüglich der Tragestruktur (2) um eine Achse parallel zu der longitudinalen Achse (6) zu verhindern, 25
- Einsetzen des Flammenspreiz-Elements (16) von der vorderen Seite (3) an der vorderen Länge (14) der Zufuhrleitung (13) entlang einer zweiten Verbindungsachse (20) transversal zu der ersten Verbindungsachse (19) und parallel zu der longitudinalen Achse (6), 30
- Einsetzen der vorderen Länge (14) der Zufuhrleitung (13) und des Flammenspreiz-Elements (16) beide entlang der zweiten Verbindungsachse (20) in eine Durchgangsöffnung (21) der hinteren Wand (12), 35
- Bilden einer Anlagefläche (22) an dem Flammenspreiz-Element (16) und Anlegen der vorderen Länge (14) der Zufuhrleitung (13) von der hinteren Seite (4) gegen die Anlagefläche (22), um so eine weitere Verlagerung des Flammenspreiz-Elements (16) bezüglich der Zufuhrleitung (13) in Richtung der hinteren Seite (4) zu verhindern, 40
- Bilden einer Stoppfläche (23) an dem Flammenspreiz-Element (16) und Anlegen der hinteren Wand (12) von der vorderen Seite (3) gegen die Stoppfläche (23), um so eine weitere Verlagerung der hinteren Wand (12) in Richtung der 45

hinteren Seite (4) zu verhindern.

Revendications

1. Brûleur à gaz portatif (1), comprenant :

- une structure de support (2) ayant une face avant (3) et une face arrière (4) opposée à la face avant (3),
- une paroi latérale tubulaire (5) raccordée à la structure de support (2) et ayant un axe longitudinal (6), la paroi tubulaire (5) définissant à l'intérieur une chambre de combustion (7) et ayant une extrémité avant (8) ouverte et faisant face à la face avant (3) ainsi qu'une extrémité arrière (9) faisant face à la face arrière (4),
- une paroi arrière (12) raccordée à la paroi latérale (5) près de l'extrémité arrière (9) et définissant la chambre de combustion (7) sur la face arrière (4),
- un tube d'alimentation (13) pour alimenter la chambre de combustion (7) en gaz combustible, ledit tube d'alimentation (13) ayant une longueur avant (14) s'étendant à travers la paroi arrière (12) à l'intérieur de la chambre de combustion (7) et une longueur arrière (15) s'étendant à l'extérieur de la chambre de combustion,

caractérisé en ce que :

- la longueur arrière (15) du tube d'alimentation (13) est raccordée à la structure de support (2) et un élément diffuseur de flamme (16) est raccordé à un orifice de sortie (16) de la longueur avant (14) du tube d'alimentation (13),

et en ce qu'au moins un des raccords :

- entre le tube d'alimentation (13) et la structure de support (2),
- entre l'élément diffuseur de flamme (16), le tube d'alimentation (13) et la paroi arrière (12),
- entre la paroi arrière (12) et la paroi latérale (5),

est un ajustement avec jeu.

2. Brûleur à gaz portatif (1) selon la revendication 1, dans lequel :

- la paroi latérale (5) est verrouillée sur la structure de support (2) de façon à empêcher une translation de la paroi latérale (5), par rapport à la structure de support (2), parallèle à l'axe longitudinal (6), et
- la longueur arrière (15) du tube d'alimentation (13) est insérée dans un siège de tube (18) de la structure de support (2) le long d'un premier

axe de raccordement (19) transversal à l'axe longitudinal (6) de façon à empêcher une translation du tube d'alimentation (13), par rapport à la structure de support (2), parallèle à l'axe longitudinal (6) et une rotation du tube d'alimentation (13), par rapport à la structure de support (2), autour d'un axe parallèle à l'axe longitudinal (6), et

- l'élément diffuseur de flamme (16) est inséré de la face avant (3) sur la longueur avant (14) du tube d'alimentation (13) le long d'un deuxième axe de raccordement (20) transversal au premier axe de raccordement (19) et parallèle à l'axe longitudinal (6), et

- la longueur avant (14) du tube d'alimentation (13) et l'élément diffuseur de flamme (16) sont tous deux insérés le long du deuxième axe de raccordement (20) dans une ouverture de passage (21) de la paroi arrière (12), et

- la longueur avant (14) du tube d'alimentation (13) vient buter de la face arrière (4) contre une surface de butée (22) de l'élément diffuseur de flamme (16) de façon à empêcher une translation de l'élément diffuseur de flamme (16) par rapport au tube d'alimentation (13) vers la face arrière (4), et

- la paroi arrière (12) vient buter de la face avant (3) contre une surface d'arrêt (23) de l'élément diffuseur de flamme (16) de façon à empêcher une translation de la paroi arrière (12) par rapport à l'élément diffuseur de flamme (16) vers la face arrière (4).

3. Brûleur (1) selon la revendication 2, dans lequel la paroi arrière (12) vient buter de la face arrière (4) contre une ou plusieurs saillies (26) de l'élément diffuseur de flamme (16) de façon à verrouiller la paroi arrière (12) entre la surface d'arrêt (23) et la saillie (26) et à empêcher une translation de celle-ci par rapport à l'élément diffuseur de flamme (16) dans les deux directions le long du deuxième axe de raccordement (20).

4. Brûleur (1) selon la revendication 2 ou 3, dans lequel la paroi arrière (12) est raccordée à la paroi latérale (5) par un couplage géométrique empêchant une rotation relative de celle-ci autour d'un axe parallèle à l'axe longitudinal (6).

5. Brûleur (1) selon l'une des revendications 2 à 4, dans lequel un bord arrière (9) de la paroi latérale forme une ou plusieurs rainures (28) ouvertes vers la face arrière (4) recevant des portions de couplage (29) de la paroi arrière (12).

6. Brûleur (1) selon la revendication précédente, dans lequel la paroi arrière (12) comprend :

- une feuille métallique en forme de disque circulaire ayant un diamètre extérieur inférieur à un diamètre intérieur de l'extrémité arrière (9) de la paroi latérale (5),
- une armature de renforcement (30) raccordée à la feuille en forme de disque et formant un anneau de renforcement autour de l'ouverture de passage (21) et une pluralité de nervures s'étendant de l'anneau de renforcement radialement vers l'extérieur et ayant des extrémités libres faisant saillie au-delà du périmètre extérieur de la feuille en forme de disque et formant les portions de couplage (29).
7. Brûleur (1) selon l'une des revendications 2 à 6, dans lequel la paroi arrière (12) forme une fente (31) près de l'ouverture de passage (21) et une vis d'agrandissement (32) ayant un diamètre supérieur à la largeur minimum de la fente (31) est vissée dans ladite fente pour déformer un bord de l'ouverture de passage (21) radialement vers l'intérieur.
8. Brûleur (1) selon l'une des revendications 2 à 7, dans lequel la paroi latérale (5) est verrouillée sur la structure de support (2) par un raccord à vis.
9. Brûleur (1) selon l'une des revendications 2 à 8, dans lequel l'insertion de la longueur arrière (15) du tube d'alimentation (13) dans le siège de tube (18) met en oeuvre un ajustement sans soudures et éléments de raccordement supplémentaires.
10. Brûleur (1) selon l'une des revendications 2 à 9, dans lequel le premier axe de raccordement (19) est sensiblement perpendiculaire à l'axe longitudinal (6).
11. Brûleur (1) selon l'une des revendications 2 à 10, dans lequel l'insertion de l'élément diffuseur de flamme (16) sur la longueur avant (14) du tube d'alimentation (13) met en oeuvre un ajustement de jeu exempt de soudures ou d'éléments de raccordement supplémentaires.
12. Brûleur (1) selon l'une des revendications 2 à 11, dans lequel l'élément diffuseur de flamme (16) comprend :
- une plaque avant (34) faisant face à la face avant (3),
 - une pluralité d'ailes arrière (35) s'étendant de la plaque avant (34) vers la face arrière (4) et définissant un siège arrière recevant, par ajustement, l'orifice de sortie (17) du tube d'alimentation (13),
 - une ou plusieurs ailes d'arrêt (36) s'étendant de la plaque avant (34) vers la face arrière (4) et ayant des extrémités libres pliées radialement vers l'extérieur et formant la surface d'arrêt (23).
13. Brûleur (1) selon la revendication 12, dans lequel :
- les ailes arrière (35) peuvent dévier élastiquement vers l'extérieur et exercer une force élastique sur le tube d'alimentation (13) pour le maintenir élastiquement sur le siège arrière,
 - les ailes arrière (35) forment un épaulement qui forme la surface de butée (22),
 - les ailes d'arrêt (36) peuvent dévier élastiquement et exercer une précharge élastique sur la paroi arrière (12) pour la maintenir élastiquement en place.
14. Procédé de montage d'un brûleur à gaz portatif (1), comprenant :
- une structure de support (2) ayant une face avant (3) et une face arrière (4) opposée à la face avant (3),
 - une paroi latérale tubulaire (5) raccordée à la structure de support (2) et ayant un axe longitudinal (6), la paroi tubulaire (5) définissant à l'intérieur une chambre de combustion (7) et ayant une extrémité avant (8) ouverte et faisant face à la face avant (3) ainsi qu'une extrémité arrière (9) faisant face à la face arrière (4),
 - une paroi arrière (12) raccordée à la paroi latérale (5) près de l'extrémité arrière (9) et définissant la chambre de combustion (7) sur la face arrière (4),
 - un tube d'alimentation (13) pour alimenter la chambre de combustion (7) en gaz combustible, ledit tube d'alimentation (13) ayant une longueur avant (14) s'étendant à travers la paroi arrière (12) à l'intérieur de la chambre de combustion (7) et une longueur arrière (15) s'étendant à l'extérieur de la chambre de combustion et raccordée à la structure de support (2),
 - un élément diffuseur de flamme (16) raccordé à un orifice de sortie (16) de la longueur avant (14) du tube d'alimentation (13), **caractérisé en ce que** ledit procédé comprenant l'étape ou les étapes d'exécution d'au moins un des raccordements :
 - entre le tube d'alimentation (13) et la structure de support (2),
 - entre l'élément diffuseur de flamme (16), le tube d'alimentation (13), et la paroi arrière (12),
 - entre la paroi arrière (12) et la paroi latérale (5),
- par un ajustement avec jeu ou un ajustement d'interférence.
15. Procédé selon la revendication 14, comprenant les étapes de :
- verrouillage de la paroi latérale (5) sur la structure de support (2) de façon à empêcher une

translation de la paroi latérale (5), par rapport à la structure de support (2), parallèle à l'axe longitudinal (6),

- insertion de la longueur arrière (15) du tube d'alimentation (13) dans un siège de tube (18) de la structure de support (2) le long d'un premier axe de raccordement (19) transversal à l'axe longitudinal (6) de façon à empêcher une translation du tube d'alimentation (13), par rapport à la structure de support (2), parallèle à l'axe longitudinal (6) et une rotation du tube d'alimentation (13), par rapport à la structure de support (2), autour d'un axe parallèle à l'axe longitudinal (6),

- insertion de l'élément diffuseur de flamme (16) de la face avant (3) sur la longueur avant (14) du tube d'alimentation (13) le long d'un deuxième axe de raccordement (20) transversal au premier axe de raccordement (19) et parallèle à l'axe longitudinal (6), et

- insertion de la longueur avant (14) du tube d'alimentation (13) et de l'élément diffuseur de flamme (16) tous deux le long du deuxième axe de raccordement (20) dans une ouverture de passage (21) de la paroi arrière (12),

- formation d'une surface de butée (22) au niveau de l'élément diffuseur de flamme (16) et butée de la longueur avant (14) du tube d'alimentation (13) de la face arrière (4) contre ladite surface de butée (22) de façon à empêcher une translation supplémentaire de l'élément diffuseur de flamme (16) par rapport au tube d'alimentation (13) vers la face arrière (4),

- formation d'une surface d'arrêt (23) au niveau de l'élément diffuseur de flamme (16) et butée de la paroi arrière (12) de la face avant (3) contre ladite surface d'arrêt (23) de façon à empêcher une translation supplémentaire de la paroi arrière (12) vers la face arrière (4).

40

45

50

55

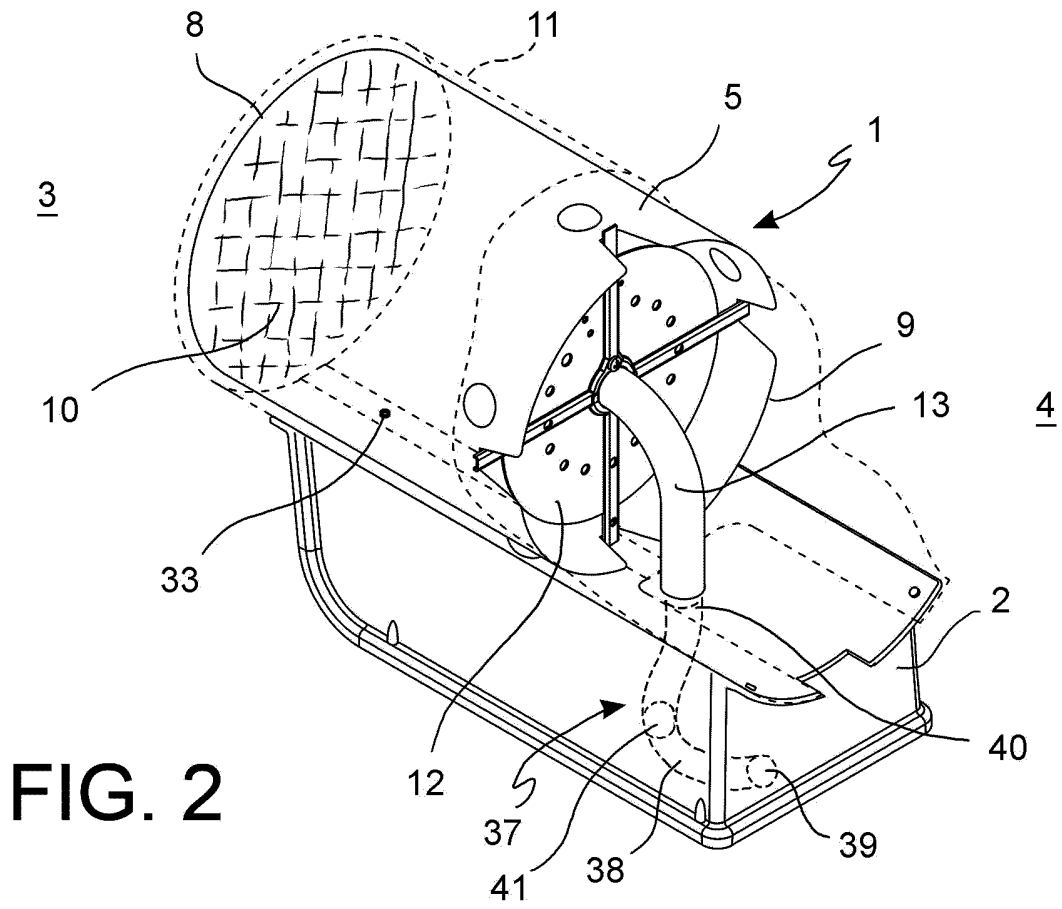
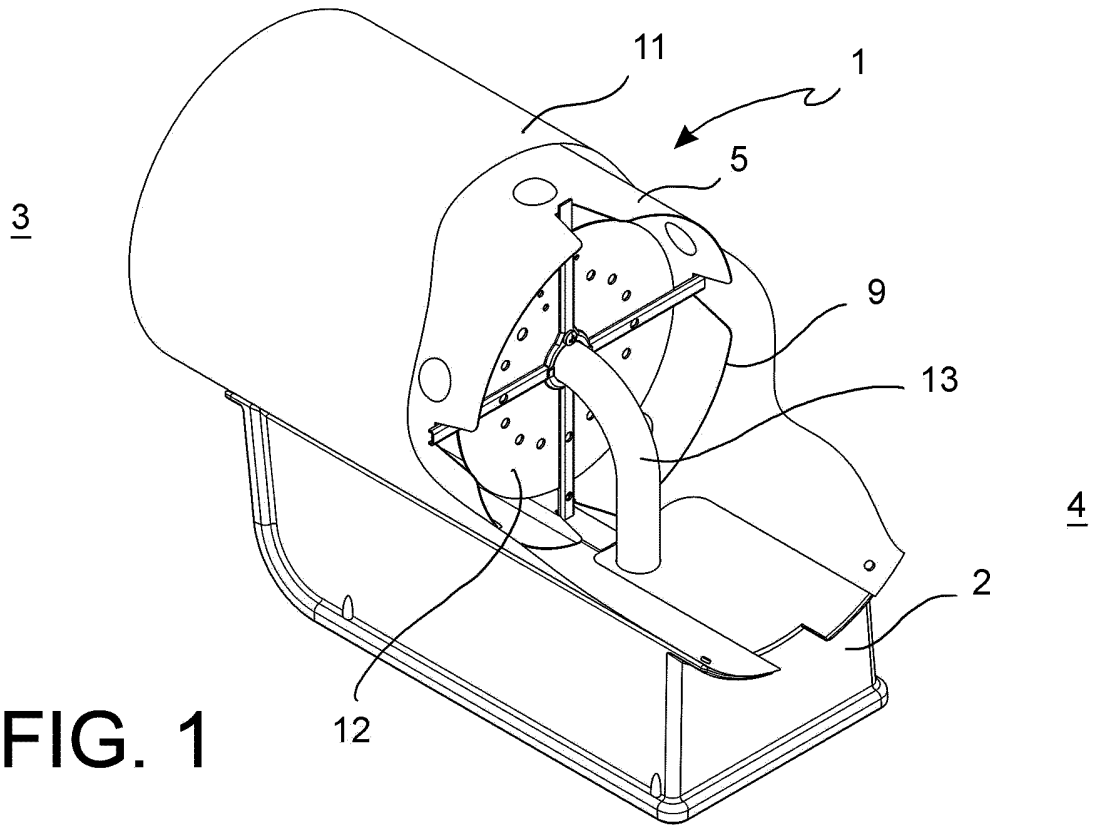

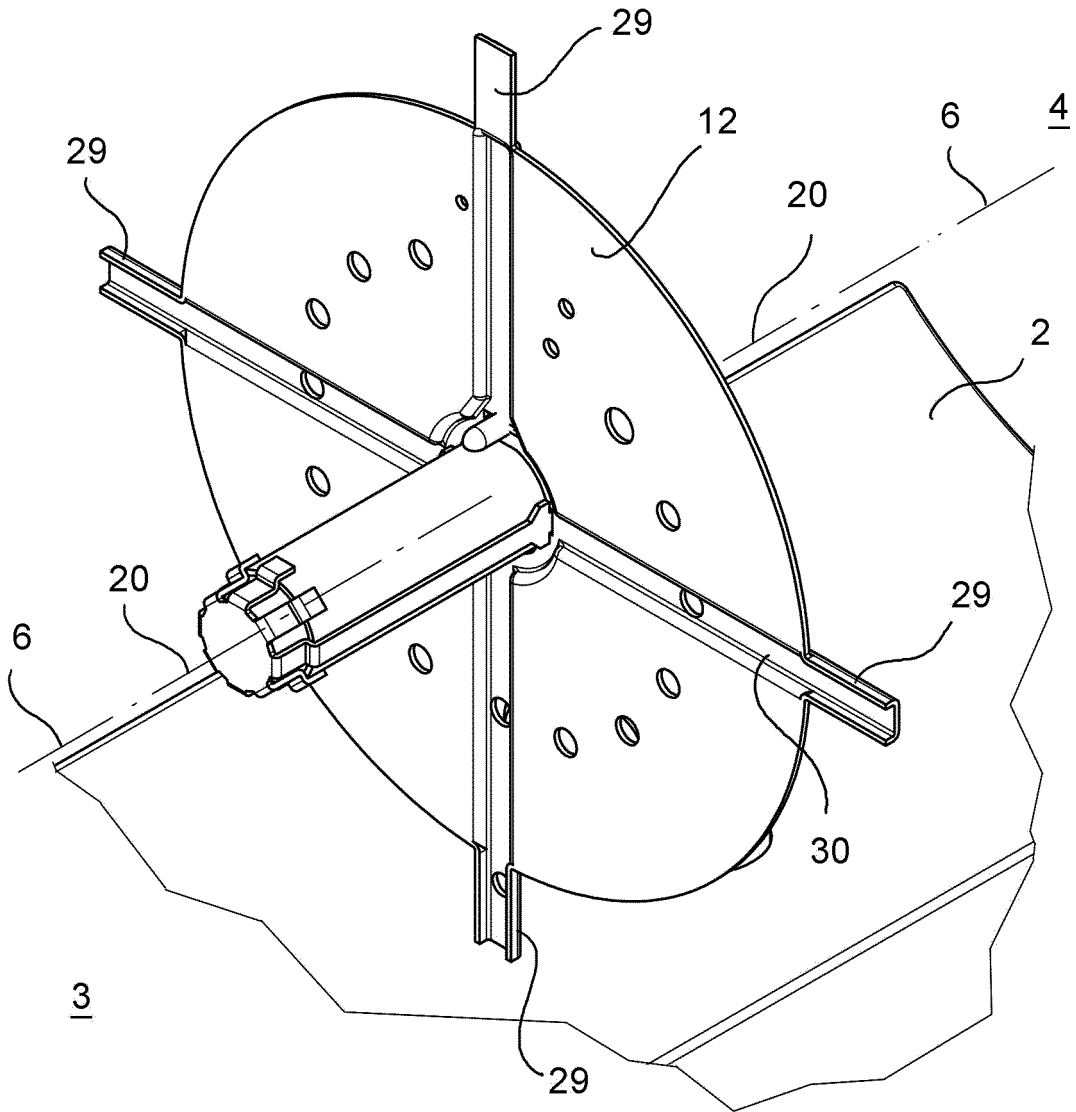

FIG. 3

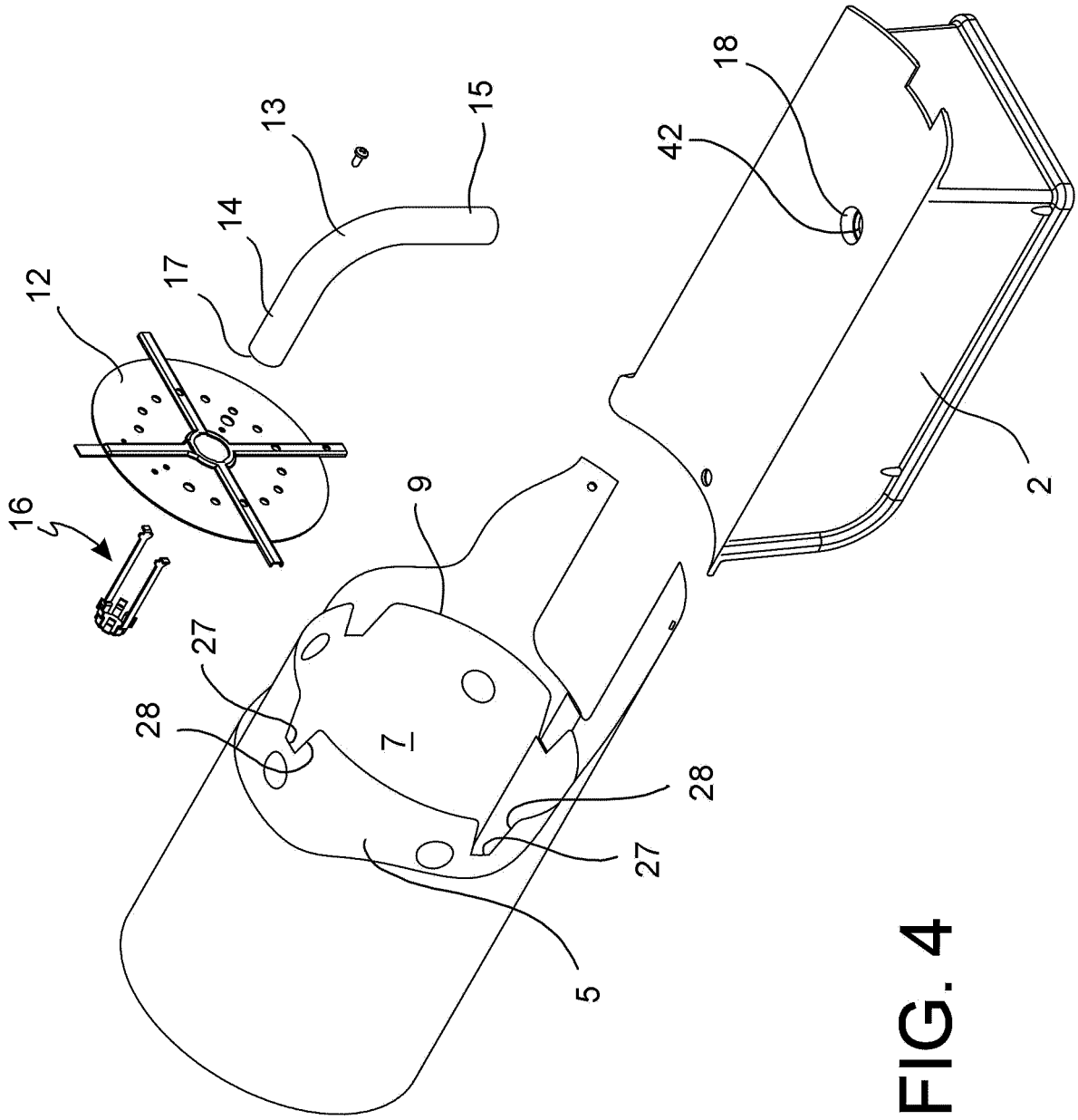

FIG. 4

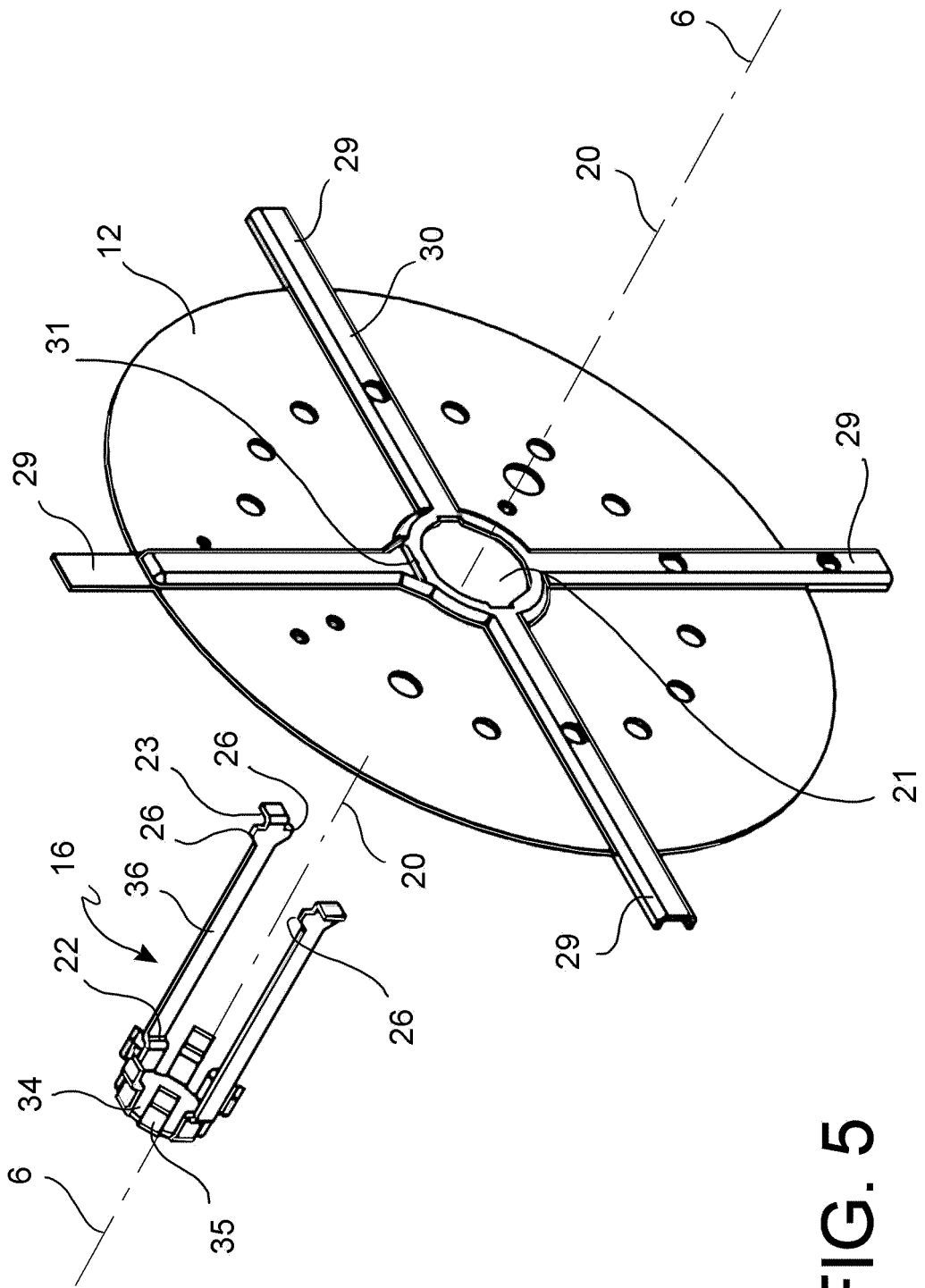

FIG. 5

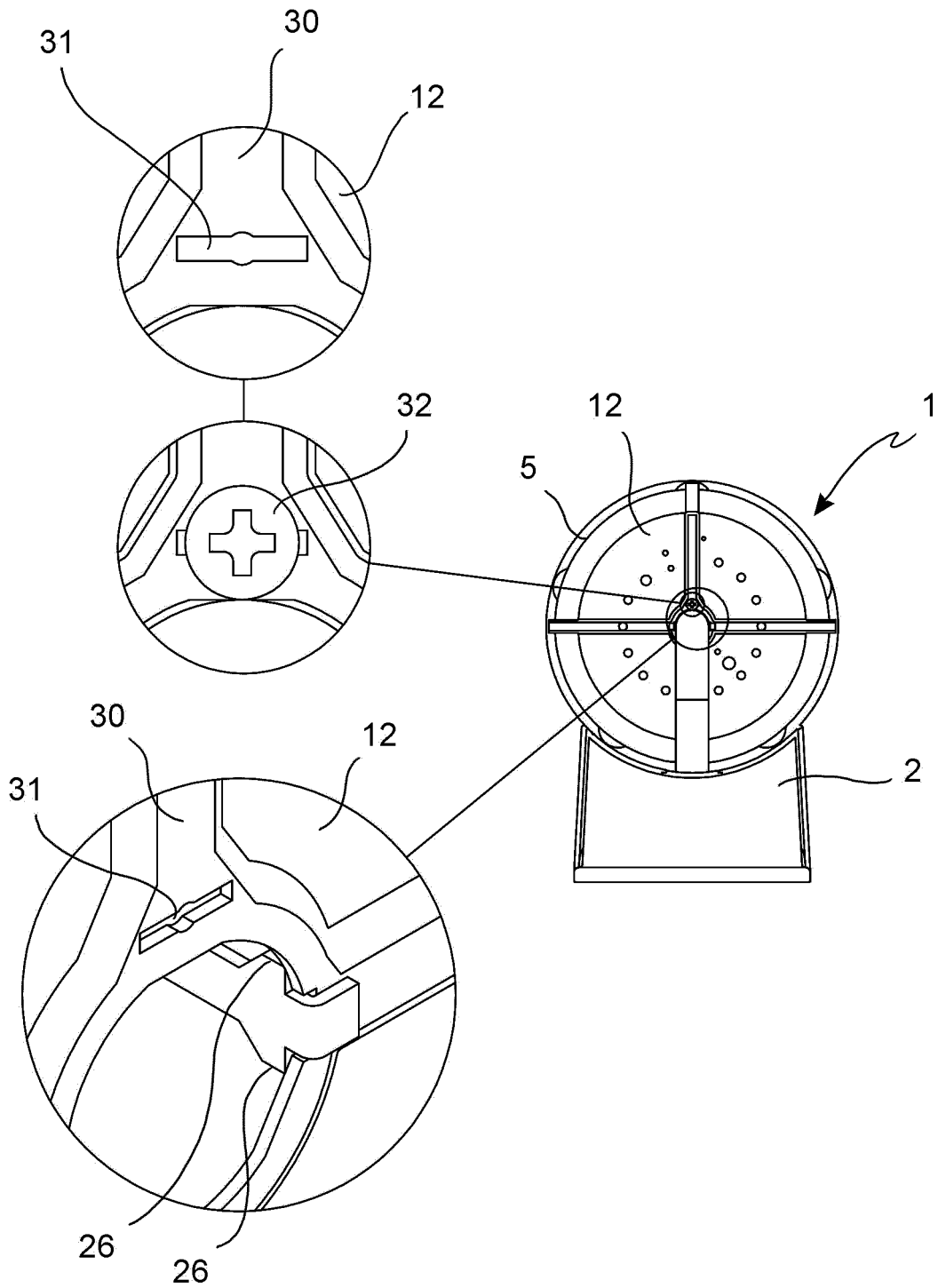

FIG. 6

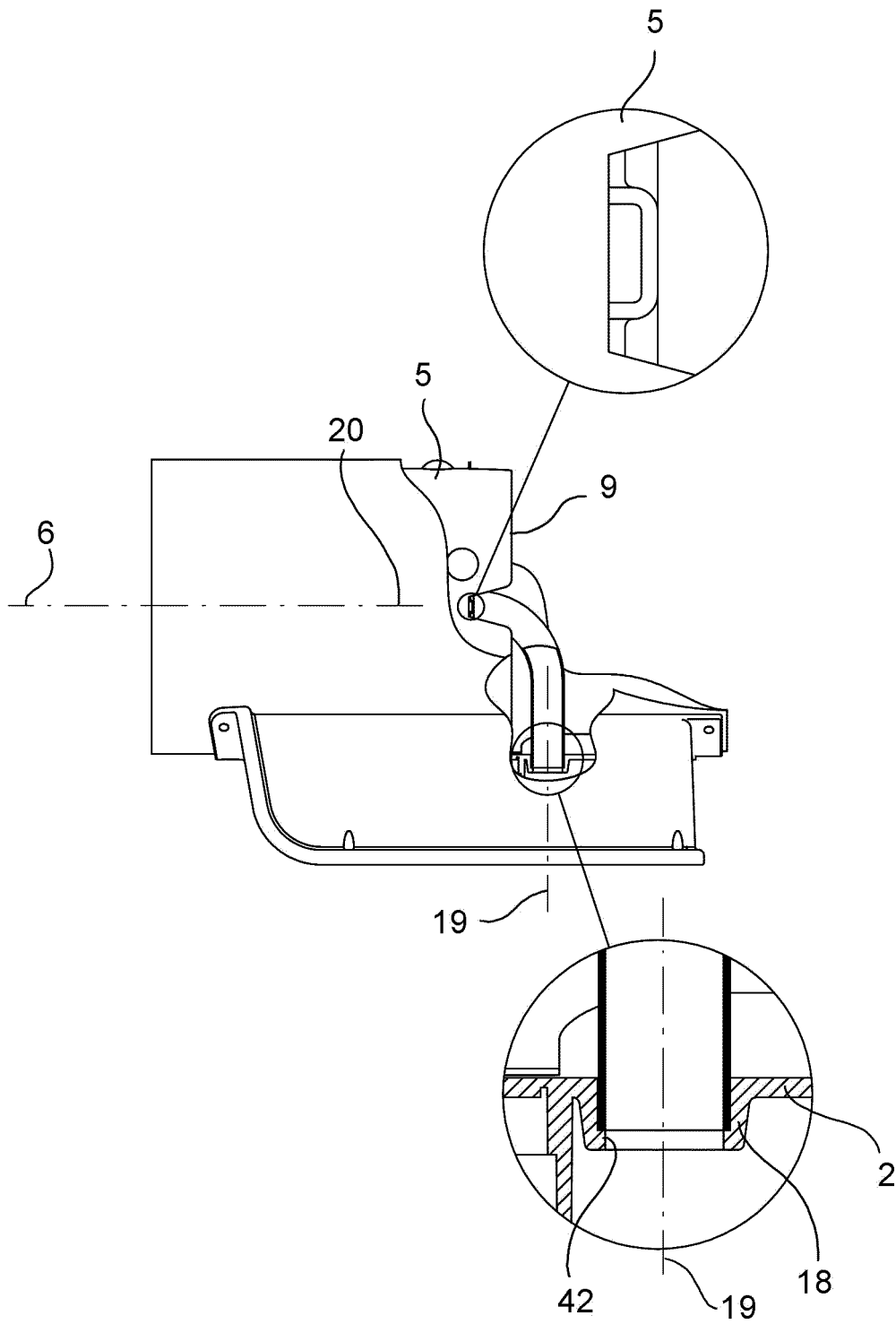
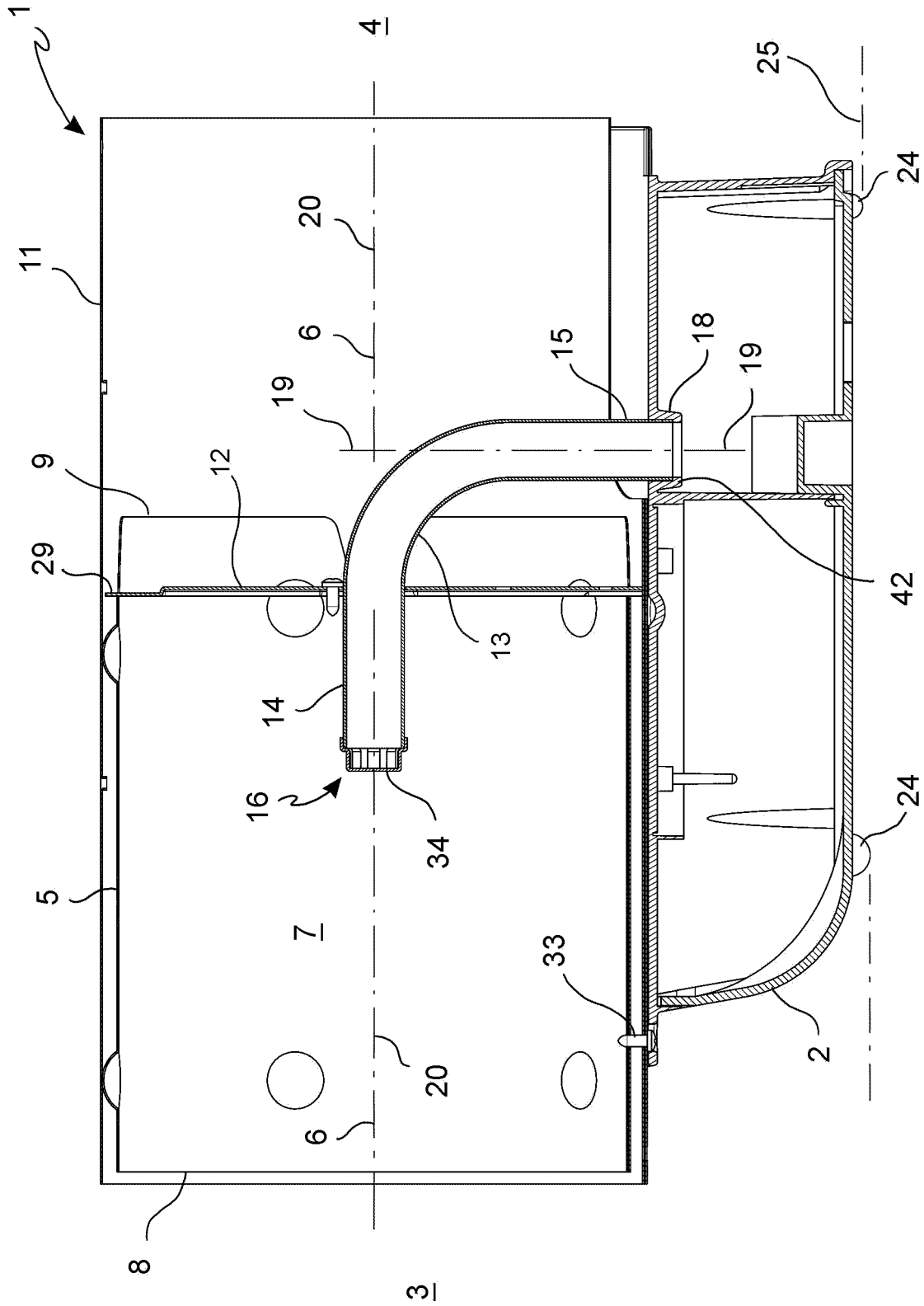
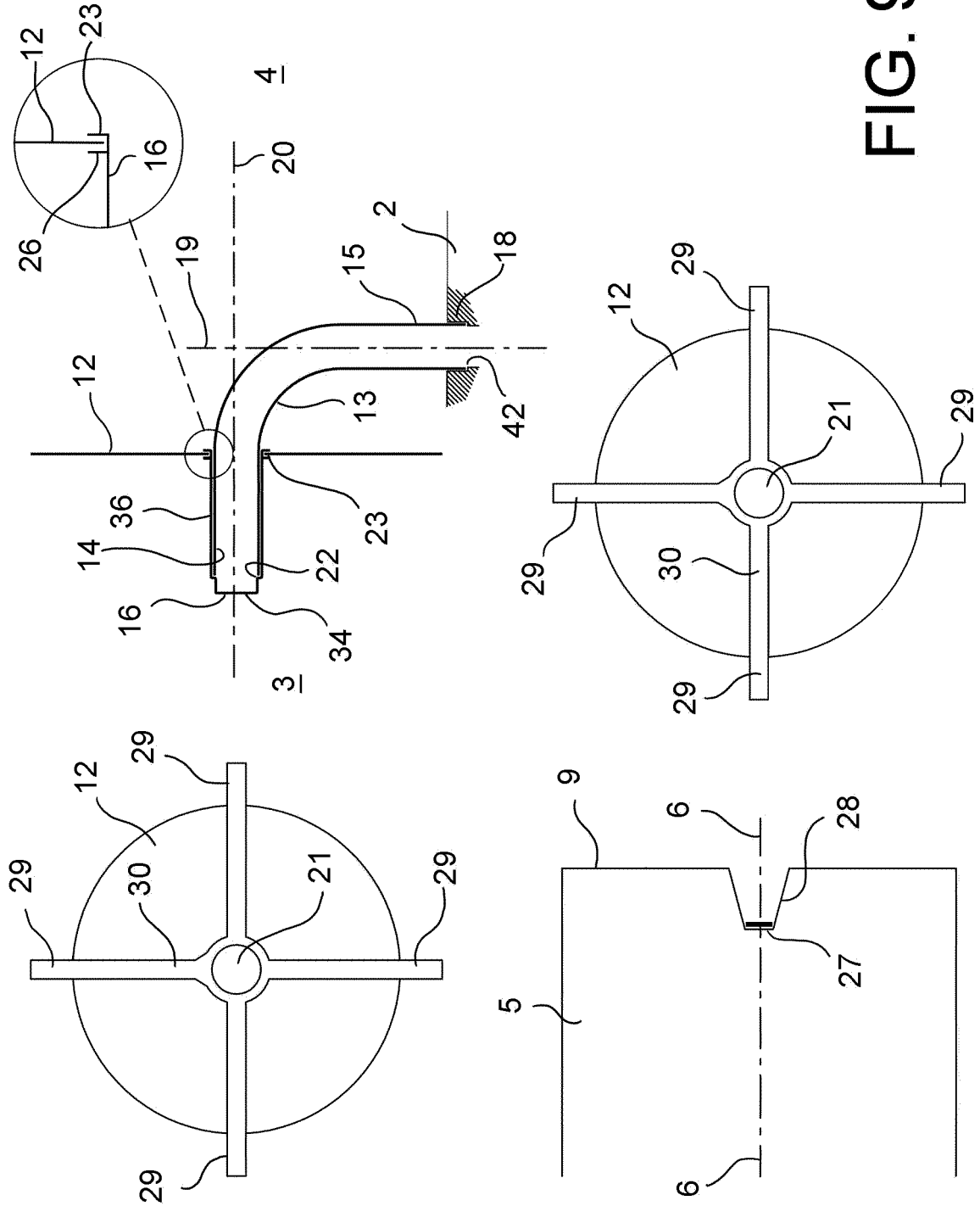

FIG. 7





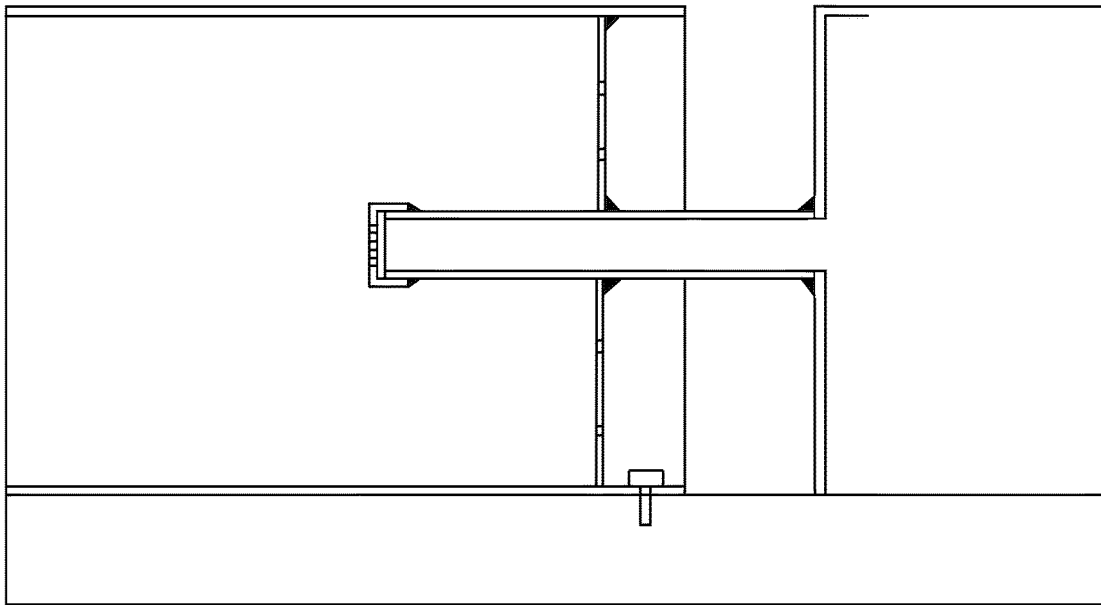

FIG. 10

REFERENCES CITED IN THE DESCRIPTION

This list of references cited by the applicant is for the reader's convenience only. It does not form part of the European patent document. Even though great care has been taken in compiling the references, errors or omissions cannot be excluded and the EPO disclaims all liability in this regard.

Patent documents cited in the description

- US 2815019 A [0001]